



Advanced Configuration and Power Interface (ACPI) Specification

Release 6.5

UEFI Forum, Inc.

Aug 29, 2022

CONTENTS

1	Introduction	1
1.1	Principal Goals	1
1.1.1	Principle of Inclusive Terminology	2
1.2	Power Management Rationale	2
1.3	Legacy Support	3
1.4	OEM Implementation Strategy	4
1.5	Power and Sleep Buttons	4
1.6	ACPI Specification and the Structure of ACPI	4
1.7	OS and Platform Compliance	6
1.7.1	Platform Implementations of ACPI-defined Interfaces	6
1.7.1.1	Recommended Features and Interface Descriptions for Design Guides	6
1.7.1.2	Terminology Examples for Design Guides	8
1.7.2	OSPM Implementations	10
1.7.3	OS Requirements	11
1.8	Target Audience	11
1.9	Document Organization	12
1.9.1	ACPI Introduction and Overview	12
1.9.2	Programming Models	12
1.9.3	Implementation Details	13
1.9.4	Technical Reference	13
1.9.5	Revision Numbers	14
1.10	Related Documents	14
2	Definition of Terms	15
2.1	General ACPI Terminology	15
2.2	Global System State Definitions	21
2.3	Device Power State Definitions	23
2.3.1	Device Performance States	24
2.4	Sleeping and Soft-off State Definitions	24
2.5	Processor Power State Definitions	25
2.6	Device and Processor Performance State Definitions	25
3	ACPI Concepts	26
3.1	System Power Management	27
3.2	Power States	27
3.2.1	Power Button	28
3.2.2	Platform Power Management Characteristics	29
3.2.2.1	Mobile PC	29
3.2.2.2	Desktop PCs	29
3.2.2.3	Multiprocessor and Server PCs	29

3.3	Device Power Management	30
3.3.1	Device Power Management Model	30
3.3.2	Power Management Standards	31
3.3.3	Device Power States	31
3.3.4	Device Power State Definitions	31
3.4	Controlling Device Power	32
3.4.1	Getting Device Power Capabilities	32
3.4.2	Setting Device Power States	32
3.4.3	Getting Device Power Status	33
3.4.4	Waking the System	33
3.4.5	Example: Modem Device Power Management	34
3.4.5.1	Obtaining the Modem Capabilities	35
3.4.5.2	Setting the Modem Power State	35
3.4.5.3	Obtaining the Modem Power Status	35
3.4.5.4	Waking the System	36
3.5	Processor Power Management	36
3.6	Device and Processor Performance States	36
3.7	Configuration and “Plug and Play”	37
3.7.1	Device Configuration Example: Configuring the Modem	37
3.7.2	NUMA Nodes	37
3.8	System Events	37
3.9	Battery Management	38
3.9.1	Battery Communications	38
3.9.2	Battery Capacity	39
3.9.3	Battery Gas Gauge	39
3.9.4	Low Battery Levels	40
3.9.4.1	Emergency Shutdown	41
3.9.5	Battery Calibration	41
3.9.6	Battery Charge Limiting	42
3.10	Thermal Management Concepts	43
3.10.1	Active and Passive Cooling Modes	43
3.10.2	Performance vs. Energy Conservation	44
3.10.3	Acoustics (Noise)	44
3.10.4	Multiple Thermal Zones	44
3.11	Flexible Platform Architecture Support	44
3.11.1	Hardware-reduced ACPI	45
3.11.1.1	Interrupt-based Wake Events	45
3.11.2	Low-Power Idle	45
3.11.2.1	Low Power S0 Idle Capable Flag	45
3.11.3	Connection Resources	46
3.11.3.1	Supported Platforms	46
4	ACPI Hardware Specification	48
4.1	Hardware-Reduced ACPI	48
4.1.1	Hardware-Reduced Events	49
4.1.1.1	GPIO-Signaled Events or Interrupt Signaled Events	49
4.1.1.2	Interrupt-based Wake Events	49
4.2	Fixed Hardware Programming Model	49
4.3	Generic Hardware Programming Model	50
4.4	Diagram Legend	52
4.5	Register Bit Notation	52
4.6	The ACPI Hardware Model	53
4.6.1	Hardware Reserved Bits	56
4.6.2	Hardware Ignored Bits	56

4.6.3	Hardware Write-Only Bits	56
4.6.4	Cross Device Dependencies	57
4.6.4.1	Example 1: Related Device Interference	57
4.6.4.2	Example 2: Unrelated Device Interference	57
4.7	ACPI Hardware Features	57
4.8	ACPI Register Model	59
4.8.1	ACPI Register Summary	61
4.8.1.1	PM1 Event Registers	62
4.8.1.2	PM1 Control Registers	63
4.8.1.3	PM2 Control Register	63
4.8.1.4	PM Timer Register	63
4.8.1.5	Processor Control Block (P_BLK)	63
4.8.1.6	General-Purpose Event Registers	64
4.8.2	Fixed Hardware Features	64
4.8.2.1	Power Management Timer	64
4.8.2.2	Console Buttons	65
4.8.2.3	Sleeping/Wake Control	70
4.8.2.4	Real Time Clock Alarm	71
4.8.2.5	Legacy/ACPI Select and the SCI Interrupt	72
4.8.2.6	Processor Control	73
4.8.3	Fixed Hardware Registers	74
4.8.3.1	PM1 Event Grouping	74
4.8.3.2	PM1 Control Grouping	77
4.8.3.3	Power Management Timer (PM_TMR)	79
4.8.3.4	PM2 Control (PM2_CNT)	79
4.8.3.5	Processor Register Block (P_BLK)	80
4.8.3.6	Reset Register	81
4.8.3.7	Sleep Control and Status Registers	82
4.8.4	Generic Hardware Registers	83
4.8.4.1	General-Purpose Event Register Blocks	85
4.8.4.2	Example Generic Devices	87
5	ACPI Software Programming Model	90
5.1	Overview of the System Description Table Architecture	90
5.1.1	Address Space Translation	93
5.2	ACPI System Description Tables	93
5.2.1	Reserved Bits and Fields	94
5.2.1.1	Reserved Bits and Software Components	94
5.2.1.2	Reserved Values and Software Components	94
5.2.1.3	Reserved Hardware Bits and Software Components	94
5.2.1.4	Ignored Hardware Bits and Software Components	95
5.2.2	Compatibility	95
5.2.3	Address Format	95
5.2.3.1	Functional Fixed Hardware	95
5.2.3.2	Generic Address Structure	96
5.2.4	Universally Unique Identifiers (UUIDs)	98
5.2.5	Root System Description Pointer (RSDP)	98
5.2.5.1	Finding the RSDP on IA-PC Systems	98
5.2.5.2	Finding the RSDP on UEFI Enabled Systems	98
5.2.5.3	Root System Description Pointer (RSDP) Structure	99
5.2.6	System Description Table Header	99
5.2.7	Root System Description Table (RSDT)	104
5.2.8	Extended System Description Table (XSDT)	104
5.2.9	Fixed ACPI Description Table (FADT)	105

5.2.9.1	Preferred PM Profile System Types	118
5.2.9.2	System Type Attributes	119
5.2.9.3	IA-PC Boot Architecture Flags	119
5.2.9.4	ARM Architecture Boot Flags	120
5.2.10	Firmware ACPI Control Structure (FACS)	121
5.2.10.1	Global Lock	123
5.2.11	Definition Blocks	125
5.2.11.1	Differentiated System Description Table (DSDT)	126
5.2.11.2	Secondary System Description Table (SSDT)	126
5.2.11.3	Persistent System Description Table (PSDT)	127
5.2.12	Multiple APIC Description Table (MADT)	127
5.2.12.1	MADT Processor Local APIC / SAPIC Structure Entry Order	130
5.2.12.2	Processor Local APIC Structure	130
5.2.12.3	I/O APIC Structure	131
5.2.12.4	Platforms with APIC and Dual 8259 Support	131
5.2.12.5	Interrupt Source Override Structure	132
5.2.12.6	Non-Maskable Interrupt (NMI) Source Structure	133
5.2.12.7	Local APIC NMI Structure	133
5.2.12.8	Local APIC Address Override Structure	134
5.2.12.9	I/O SAPIC Structure	134
5.2.12.10	Local SAPIC Structure	135
5.2.12.11	Platform Interrupt Source Structure	135
5.2.12.12	Processor Local x2APIC Structure	137
5.2.12.13	Local x2APIC NMI Structure	137
5.2.12.14	GIC CPU Interface (GICC) Structure	138
5.2.12.15	GIC Distributor (GICD) Structure	140
5.2.12.16	GIC MSI Frame Structure	141
5.2.12.17	GIC Redistributor (GICR) Structure	142
5.2.12.18	GIC Interrupt Translation Service (ITS) Structure	142
5.2.12.19	Multiprocessor Wakeup Structure	142
5.2.12.20	Core Programmable Interrupt Controller (CORE PIC) Structure	144
5.2.12.21	Legacy I/O Programmable Interrupt Controller(LIO PIC) Structure	145
5.2.12.22	HyperTransport Programmable Interrupt Controller (HT PIC) Structure	145
5.2.12.23	Extend I/O Programmable Interrupt Controller (EIO PIC) Structure	146
5.2.12.24	MSI Programmable Interrupt Controller (MSI PIC) Structure	146
5.2.12.25	Bridge I/O Programmable Interrupt Controller (BIO PIC) Structure	147
5.2.12.26	LPC Programmable Interrupt Controller (LPC PIC) Structure	147
5.2.13	Global System Interrupts	148
5.2.14	Smart Battery Table (SBST)	150
5.2.15	Embedded Controller Boot Resources Table (ECDT)	151
5.2.16	System Resource Affinity Table (SRAT)	153
5.2.16.1	Processor Local APIC/SAPIC Affinity Structure	154
5.2.16.2	Memory Affinity Structure	154
5.2.16.3	Processor Local x2APIC Affinity Structure	155
5.2.16.4	GICC Affinity Structure	156
5.2.16.5	GIC Interrupt Translation Service (ITS) Affinity Structure	156
5.2.16.6	Generic Initiator Affinity Structure	157
5.2.16.7	Generic Port Affinity Structure	158
5.2.17	System Locality Information Table (SLIT)	159
5.2.18	Corrected Platform Error Polling Table (CPEP)	160
5.2.18.1	Corrected Platform Error Polling Processor Structure	161
5.2.19	Maximum System Characteristics Table (MSCT)	162
5.2.19.1	Maximum Proximity Domain Information Structure	163
5.2.20	ACPI RAS Feature Table (RAS_F)	164

5.2.20.1	RASF PCC Sub Channel Identifier	165
5.2.20.2	Using PCC registers	165
5.2.20.3	RASF Communication Channel	165
5.2.20.4	Platform RAS Capabilities	166
5.2.20.5	Parameter Block	167
5.2.21	ACPI RAS2 Feature Table (RAS2)	168
5.2.21.1	Common Definitions	169
5.2.21.2	Memory RAS Features – Feature Type 0	171
5.2.22	Memory Power State Table (MPST)	175
5.2.22.1	MPST PCC Sub Channel	177
5.2.22.2	Memory Power State	180
5.2.22.3	Action Sequence	181
5.2.22.4	Memory Power Node	182
5.2.22.5	Memory Power State Structure	184
5.2.22.6	Memory Power State Characteristics structure	184
5.2.22.7	Autonomous Memory Power Management	185
5.2.22.8	Handling BIOS Reserved Memory	186
5.2.22.9	Interaction with NUMA processor and memory affinity tables	186
5.2.22.10	Interaction with Memory Hot Plug	186
5.2.22.11	OS Memory Allocation Considerations	187
5.2.22.12	Platform Memory Topology Table (PMTT)	187
5.2.23	Boot Graphics Resource Table (BGRT)	190
5.2.23.1	Version	192
5.2.23.2	Status	192
5.2.23.3	Image Type	192
5.2.23.4	Image Address	192
5.2.23.5	Image Offset	192
5.2.24	Firmware Performance Data Table (FPDT)	193
5.2.24.1	Performance Record Format	194
5.2.24.2	FPDT Performance Record Types	195
5.2.24.3	Runtime Performance Record Types	195
5.2.24.4	Firmware Basic Boot Performance Table Pointer Record	195
5.2.24.5	S3 Performance Table Pointer Record	196
5.2.24.6	Firmware Basic Boot Performance Table	196
5.2.24.7	Firmware Basic Boot Performance Data Record	197
5.2.24.8	S3 Performance Table	197
5.2.25	Generic Timer Description Table (GTDT)	198
5.2.25.1	GT Block Structure	201
5.2.25.2	Arm Generic Watchdog Structure	203
5.2.26	NVDIMM Firmware Interface Table (NFIT)	204
5.2.26.1	Overview	204
5.2.26.2	System Physical Address (SPA) Range Structure	206
5.2.26.3	NVDIMM Region Mapping Structure	208
5.2.26.4	Interleave Structure	211
5.2.26.5	SMBIOS Management Information Structure	212
5.2.26.6	NVDIMM Control Region Structure	212
5.2.26.7	NVDIMM Block Data Window Region Structure	215
5.2.26.8	Flush Hint Address Structure	215
5.2.26.9	Platform Capabilities Structure	216
5.2.26.10	NVDIMM Representation Format	217
5.2.27	Secure Devices (SDEV) ACPI Table	218
5.2.27.1	Secure Device Structures	219
5.2.28	Heterogeneous Memory Attribute Table (HMAT)	223
5.2.28.1	HMAT Overview	223

5.2.28.2	Memory Side Cache Overview	224
5.2.28.3	Memory Proximity Domain Attributes Structure	224
5.2.28.4	System Locality Latency and Bandwidth Information Structure	225
5.2.28.5	Memory Side Cache Information Structure	229
5.2.29	Platform Debug Trigger Table (PDTT)	231
5.2.29.1	PDTT PCC Sub Channel	232
5.2.29.2	PDTT PCC Trigger Order	234
5.2.29.3	Example: OS Invoking Multiple Debug Triggers	234
5.2.30	Processor Properties Topology Table (PPTT)	236
5.2.30.1	Processor hierarchy node structure (Type 0)	237
5.2.30.2	Cache Type Structure - Type 1	239
5.2.31	Platform Health Assessment Table (PHAT)	243
5.2.31.1	Platform Health Assessment Record Format	243
5.2.31.2	Platform Health Assessment Record Type Format	244
5.2.31.3	Firmware Version Data Record Structure	244
5.2.31.4	Firmware Health Data Record Structure	245
5.2.31.5	Reset Reason Health Record	246
5.2.32	Virtual I/O Translation (VIOT) Table	250
5.2.32.1	Virtual I/O Translation (VIOT) Table Header	251
5.2.32.2	VIOT Node Structures	251
5.2.32.3	PCI Range Node Structure	252
5.2.32.4	Single MMIO Endpoint Node Structure	252
5.2.32.5	virtio-iommu based on virtio-pci Node Structure	253
5.2.32.6	virtio-iommu based on virtio-mmioNode Structure	253
5.2.33	Miscellaneous GUIDed Table Entries	253
5.2.34	CC Event Log ACPI Table	254
5.2.35	Storage Volume Key Location Table	255
5.3	ACPI Namespace	256
5.3.1	Predefined Root Namespaces	258
5.3.2	Objects	258
5.4	Definition Block Encoding	259
5.4.1	AML Encoding	259
5.4.2	Definition Block Loading	259
5.5	Control Methods and the ACPI Source Language (ASL)	261
5.5.1	ASL Statements	262
5.5.2	Control Method Execution	262
5.5.2.1	Arguments	262
5.5.2.2	Method Calling Convention	263
5.5.2.3	Local Variables and Locally Created Data Objects	263
5.5.2.4	Access to Operation Regions	264
5.6	ACPI Event Programming Model	290
5.6.1	ACPI Event Programming Model Components	290
5.6.2	Types of ACPI Events	291
5.6.3	Fixed Event Handling	291
5.6.4	General-Purpose Event Handling	292
5.6.4.1	_Exx, _Lxx, and _Qxx Methods for GPE Processing	293
5.6.4.2	GPE Wake Events	294
5.6.5	GPIO-signaled ACPI Events	296
5.6.5.1	Declaring GPIO Controller Devices	296
5.6.5.2	_AEI Object for GPIO-signaled Events	296
5.6.5.3	The Event (_EVT) Method for Handling GPIO-signaled Events	297
5.6.6	Device Object Notifications	298
5.6.7	Device Class-Specific Objects	303
5.6.8	Predefined ACPI Names for Objects, Methods, and Resources	305

5.6.9	Interrupt-signaled ACPI events	312
5.6.9.1	Declaring Generic Event Device	312
5.6.9.2	_CRS Object for Interrupt-signaled Events	312
5.6.9.3	The Event (_EVT) Method for Handling Interrupt-signaled Events	313
5.6.9.4	GED Wake Events	314
5.6.10	Managing a Wake Event Using Device _PRW Objects	315
5.7	Predefined Objects	315
5.7.1	_GL (Global Lock Mutex)	315
5.7.2	_OSI (Operating System Interfaces)	315
5.7.2.1	_OSI Examples	317
5.7.3	_OS (OS Name Object)	318
5.7.4	_REV (Revision Data Object)	319
5.7.5	_DLM (DeviceLock Mutex)	319
5.8	System Configuration Objects	321
5.8.1	_PIC Method	321
6	Device Configuration	322
6.1	Device Identification Objects	322
6.1.1	_ADR (Address)	323
6.1.2	_CID (Compatible ID)	324
6.1.3	_CLS (Class Code)	325
6.1.4	_DDN (DOS Device Name)	326
6.1.5	_HID (Hardware ID)	326
6.1.6	_HRV (Hardware Revision)	327
6.1.7	_MLS (Multiple Language String)	327
6.1.8	_PLD (Physical Location of Device)	328
6.1.9	_SUB (Subsystem ID)	334
6.1.10	_STR (String)	336
6.1.11	_SUN (Slot User Number)	336
6.1.12	_UID (Unique ID)	337
6.2	Device Configuration Objects	337
6.2.1	_CDM (Clock Domain)	338
6.2.2	_CRS (Current Resource Settings)	339
6.2.3	_DIS (Disable)	339
6.2.4	_DMA (Direct Memory Access)	339
6.2.5	_DSD (Device Specific Data)	341
6.2.6	_FIX (Fixed Register Resource Provider)	343
6.2.7	_GSB (Global System Interrupt Base)	345
6.2.8	_HPP (Hot Plug Parameters)	346
6.2.9	_HPX (Hot Plug Parameter Extensions)	348
6.2.9.1	PCI Setting Record (Type 0)	349
6.2.9.2	PCI-X Setting Record (Type 1)	350
6.2.9.3	PCI Express Setting Record (Type 2)	350
6.2.9.4	PCI Express Descriptor Setting Record (Type 3)	352
6.2.9.5	_HPX Example	359
6.2.10	_MAT (Multiple APIC Table Entry)	360
6.2.11	_OSC (Operating System Capabilities)	361
6.2.11.1	Rules for Evaluating _OSC	363
6.2.11.2	Platform-Wide OSPM Capabilities	364
6.2.11.3	Operating System Capabilities (_OSC) for USB	366
6.2.12	_PRS (Possible Resource Settings)	367
6.2.13	_PRT (PCI Routing Table)	367
6.2.13.1	Example: Using _PRT to Describe PCI IRQ Routing	368
6.2.14	_PXM (Proximity)	369

6.2.15	_SLI (System Locality Information)	370
6.2.16	_SRS (Set Resource Settings)	373
6.2.17	_CCA (Cache Coherency Attribute)	373
6.2.17.1	_CCA Example ASL:	374
6.2.18	_HMA(Heterogeneous Memory Attributes)	375
6.3	Device Insertion, Removal, and Status Objects	376
6.3.1	_EDL (Eject Device List)	377
6.3.2	_EJD (Ejection Dependent Device)	378
6.3.3	_EJx (Eject)	379
6.3.4	_LCK (Lock)	380
6.3.5	_OST (OSPM Status Indication)	380
6.3.5.1	Processing Sequence for Graceful Shutdown Request:	381
6.3.5.2	Processing Sequence for Error Disconnect Recover	385
6.3.6	_RMV (Remove)	385
6.3.7	_STA (Device Status)	386
6.4	Resource Data Types for ACPI	387
6.4.1	ASL Macros for Resource Descriptors	387
6.4.2	Small Resource Data Type	387
6.4.2.1	IRQ Descriptor	387
6.4.2.2	DMA Descriptor	388
6.4.2.3	Start Dependent Functions Descriptor	389
6.4.2.4	End Dependent Functions Descriptor	390
6.4.2.5	I/O Port Descriptor	390
6.4.2.6	Fixed Location I/O Port Descriptor	391
6.4.2.7	Fixed DMA Descriptor	392
6.4.2.8	Vendor-Defined Descriptor, Type 0	392
6.4.2.9	End Tag	392
6.4.3	Large Resource Data Type	393
6.4.3.1	24-Bit Memory Range Descriptor	394
6.4.3.2	Vendor-Defined Descriptor, Type 1	395
6.4.3.3	32-Bit Memory Range Descriptor	395
6.4.3.4	32-Bit Fixed Memory Range Descriptor	397
6.4.3.5	Address Space Resource Descriptors	398
6.4.3.6	Extended Interrupt Descriptor	410
6.4.3.7	Generic Register Descriptor	412
6.4.3.8	Connection Descriptors	413
6.4.3.9	Pin Function Descriptor	424
6.4.3.10	Pin Configuration Descriptor	425
6.4.3.11	Pin Group Descriptor	427
6.4.3.12	Pin Group Function Descriptor	429
6.4.3.13	Pin Group Configuration Descriptor	430
6.4.3.14	Clock Input Resource Descriptor	432
6.5	Other Objects and Control Methods	433
6.5.1	_INI (Init)	434
6.5.2	_DCK (Dock)	434
6.5.3	_BDN (BIOS Dock Name)	435
6.5.4	_REG (Region)	435
6.5.5	_BBN (Base Bus Number)	437
6.5.6	_SEG (Segment)	437
6.5.7	_GLK (Global Lock)	439
6.5.8	_DEP (Operation Region Dependencies)	439
6.5.9	_FIT (Firmware Interface Table)	440
6.5.10	NVDIMM Label Methods	441
6.5.10.1	_LSI (Label Storage Information)	441

6.5.10.2	_LSR (Label Storage Read)	442
6.5.10.3	_LSW (Label Storage Write)	442
6.5.11	_CBR (CXL Host Bridge Register Info)	443
7	Power and Performance Management	445
7.1	Power Resource Objects and the Power Management Models	445
7.2	Declaring a Power Resource Object	447
7.2.1	Defined Methods for a Power Resource	448
7.2.2	_OFF	448
7.2.3	_ON	449
7.2.4	_STA (Power Resource Status)	449
7.2.5	Passive Power Resources	449
7.3	Device Power Management Objects	450
7.3.1	_DSW (Device Sleep Wake)	451
7.3.2	_PS0 (Power State 0)	452
7.3.3	_PS1 (Power State 1)	452
7.3.4	_PS2 (Power State 2)	452
7.3.5	_PS3 (Power State 3)	453
7.3.6	_PSC (Power State Current)	453
7.3.7	_PSE (Power State for Enumeration)	453
7.3.8	_PR0 (Power Resources for D0)	454
7.3.9	_PR1 (Power Resources for D1)	454
7.3.10	_PR2 (Power Resources for D2)	455
7.3.11	_PR3 (Power Resources for D3hot)	455
7.3.12	_PRE (Power Resources for Enumeration)	456
7.3.13	_PRW (Power Resources for Wake)	456
7.3.14	_PSW (Power State Wake)	458
7.3.15	_IRC (In Rush Current)	458
7.3.16	_S1D (S1 Device State)	458
7.3.17	_S2D (S2 Device State)	459
7.3.18	_S3D (S3 Device State)	460
7.3.19	_S4D (S4 Device State)	460
7.3.20	_S0W (S0 Device Wake State)	461
7.3.21	_S1W (S1 Device Wake State)	461
7.3.22	_S2W (S2 Device Wake State)	461
7.3.23	_S3W (S3 Device Wake State)	462
7.3.24	_S4W (S4 Device Wake State)	462
7.3.25	_RST (Device Reset)	463
7.3.26	_PRR (Power Resource for Reset)	463
7.3.27	_DSC (Deepest State for Configuration)	463
7.4	OEM-Supplied System-Level Control Methods	464
7.4.1	_PTS (Prepare To Sleep)	464
7.4.2	_Sx (System States)	465
7.4.2.1	System _S0 State (Working)	467
7.4.2.2	System _S1 State (Sleeping with Processor Context Maintained)	467
7.4.2.3	System _S2 State	467
7.4.2.4	System _S3 State	468
7.4.2.5	System _S4 State	468
7.4.2.6	System _S5 State (Soft Off)	469
7.4.3	_SWS (System Wake Source)	469
7.4.4	_TTS (Transition To State)	470
7.4.5	_WAK (System Wake)	470
7.5	OSPM usage of _PTS, _TTS, and _WAK	471

8	Processor Configuration and Control	473
8.1	Processor Power States	473
8.1.1	Processor Power State C0	475
8.1.2	Processor Power State C1	476
8.1.3	Processor Power State C2	477
8.1.4	Processor Power State C3	478
8.1.5	Additional Processor Power States	478
8.2	Flushing Caches	479
8.3	Power, Performance, and Throttling State Dependencies	479
8.4	Declaring Processors	480
8.4.1	Processor Power State Control	481
8.4.1.1	_CST (C States)	481
8.4.1.2	_CSD (C-State Dependency)	483
8.4.2	Processor Hierarchy	485
8.4.2.1	Processor Container Device	487
8.4.3	Lower Power Idle States	487
8.4.3.1	Hierarchical Idle States	488
8.4.3.2	Idle State Coordination	489
8.4.3.3	_LPI (Low Power Idle States)	494
8.4.3.4	_RDI (Resource Dependencies for Idle)	506
8.4.3.5	Compatibility	509
8.4.4	Processor Throttling Controls	509
8.4.4.1	_PTC (Processor Throttling Control)	510
8.4.4.2	_TSS (Throttling Supported States)	511
8.4.4.3	_TPC (Throttling Present Capabilities)	512
8.4.4.4	_TSD (T-State Dependency)	513
8.4.4.5	_TDL (T-state Depth Limit)	516
8.4.5	Processor Performance Control	516
8.4.5.1	_PCT (Performance Control)	517
8.4.5.2	_PSS (Performance Supported States)	518
8.4.5.3	_PPC (Performance Present Capabilities)	519
8.4.5.4	Processor Performance Control Example	519
8.4.5.5	_PSD (P-State Dependency)	521
8.4.5.6	_PDL (P-state Depth Limit)	523
8.4.6	Collaborative Processor Performance Control	523
8.4.6.1	_CPC (Continuous Performance Control)	524
8.4.7	_PPE (Polling for Platform Errors)	540
8.5	Processor Aggregator Device	540
8.5.1	Logical Processor Idling	540
8.5.1.1	_PUR (Processor Utilization Request)	540
8.5.2	OSPM _OST Evaluation	541
9	ACPI-Defined Devices and Device-Specific Objects	542
9.1	Device Object Name Collision	542
9.1.1	_DSM (Device Specific Method)	542
9.2	_SI System Indicators	545
9.2.1	_SST (System Status)	545
9.2.2	_MSG (Message)	545
9.2.3	_BLT (Battery Level Threshold)	546
9.3	Ambient Light Sensor Device	546
9.3.1	Overview	547
9.3.2	_ALI (Ambient Light Illuminance)	547
9.3.3	_ALT (Ambient Light Temperature)	548
9.3.4	_ALC (Ambient Light Color Chromaticity)	548

9.3.5	_ALR (Ambient Light Response)	548
9.3.6	_ALP (Ambient Light Polling)	552
9.3.7	Ambient Light Sensor Events	552
9.3.8	Relationship to Backlight Control Methods	553
9.4	Control Method Lid Device	553
9.4.1	_LID	553
9.5	Control Method Power and Sleep Button Devices	554
9.6	Generic Container Device	554
9.7	ATA Controller Devices	554
9.7.1	Objects for Both ATA and SATA Controllers	555
9.7.1.1	_GTF (Get Task File)	555
9.7.2	IDE Controller Device	556
9.7.2.1	IDE Controller-specific Objects	557
9.7.3	Serial ATA (SATA) Controller Device	558
9.7.3.1	Definitions	558
9.7.3.2	Overview	559
9.7.3.3	SATA controller-specific control methods	559
9.8	Floppy Controller Device Objects	560
9.8.1	_FDE (Floppy Disk Enumerate)	560
9.8.2	_FDI (Floppy Disk Information)	561
9.8.3	_FDM (Floppy Disk Drive Mode)	562
9.9	GPE Block Device	562
9.9.1	Matching Control Methods for Events in a GPE Block Device	563
9.10	Module Device	563
9.11	Memory Devices	566
9.11.1	Address Decoding	566
9.11.2	Memory Bandwidth Monitoring and Reporting	566
9.11.2.1	_MBM (Memory Bandwidth Monitoring Data)	567
9.11.2.2	_MSM (Memory Set Monitoring)	568
9.11.3	_OSC Definition for Memory Device	568
9.11.4	Example: Memory Device	569
9.12	_UPC (USB Port Capabilities)	569
9.12.1	USB 2.0 Host Controllers and _UPC and _PLD	574
9.12.2	SuperSpeed USB Port and Connector Mapping	576
9.12.3	USB4 Port and USB-C Connector Mapping	576
9.13	_PDO (USB Power Data Object)	580
9.14	PC/AT RTC/CMOS Devices	581
9.14.1	PC/AT-compatible RTC/CMOS Devices (PNP0B00)	581
9.14.2	Intel PIIX4-compatible RTC/CMOS Devices (PNP0B01)	582
9.14.3	Dallas Semiconductor-compatible RTC/CMOS Devices (PNP0B02)	583
9.15	User Presence Detection Device	583
9.15.1	_UPD (User Presence Detect)	583
9.15.2	_UPP (User Presence Polling)	584
9.15.3	User Presence Sensor Events	584
9.16	I/O APIC Device	584
9.17	Time and Alarm Device	585
9.17.1	Overview	585
9.17.2	_GCP (Get Capability)	588
9.17.3	_GRT (Get Real Time)	589
9.17.4	_SRT (Set Real Time)	589
9.17.5	_GWS (Get Wake alarm status)	590
9.17.6	_CWS (Clear Wake alarm status)	591
9.17.7	_STP (Set Expired Timer Wake Policy)	591
9.17.8	_STV (Set Timer Value)	592

9.17.9	_TIP (Expired Timer Wake Policy)	592
9.17.10	_TIV (Timer Values)	592
9.17.11	ACPI Wakeup Alarm Events	593
9.17.12	Relationship to Real Time Clock Alarm	593
9.17.13	Time and Alarm device as a replacement to the RTC	593
9.17.14	Relationship to UEFI time source	593
9.17.15	Example ASL code	593
9.18	Generic Buttons Device	597
9.18.1	Button Interrupts	597
9.18.2	Button Usages and Collections	598
9.18.3	Generic Buttons Device Example	599
9.19	NVDIMM Devices	600
9.19.1	Overview	600
9.19.2	NVDIMM Root Device	600
9.19.3	NVDIMM Device	601
9.19.4	Example	601
9.19.5	Loading NVDIMM drivers	602
9.19.6	Hot Plug Support	602
9.19.7	NVDIMM Root Device _DSMs	604
9.19.7.1	Input Parameters:	604
9.19.7.2	Address Range Scrubbing (ARS) Overview	604
9.19.7.3	Address Range Scrub (ARS) Error Injection Overview	605
9.19.7.4	Function Index 1 - Query ARS Capabilities	606
9.19.7.5	Function Index 2 - Start ARS	608
9.19.7.6	Function Index 3 - Query ARS Status	609
9.19.7.7	Function Index 4 - Clear Uncorrectable Error	611
9.19.7.8	Function Index 5 - Translate SPA	612
9.19.7.9	Function Index 7 - ARS Error Inject	614
9.19.7.10	Function Index 8 - ARS Error Inject Clear	616
9.19.7.11	Function Index 9 - ARS Error Inject Status Query	616
9.19.7.12	Function Index 0xA - Query ARS Error Inject Capabilities	617
9.19.8	NVDIMM Device Methods	618
9.19.8.1	_NCH (Get NVDIMM Current Health Information)	619
9.19.8.2	_NBS (Get NVDIMM Boot Status)	621
9.19.8.3	_NIC (Get NVDIMM Health Error Injection Capabilities)	621
9.19.8.4	_NIH (NVDIMM Inject/Clear Health Errors)	622
9.19.8.5	_NIG (Get NVDIMM Inject Health Error Status)	624
10	Power Source and Power Meter Devices	626
10.1	Smart Battery Subsystems	626
10.1.1	ACPI Smart Battery Status Change Notification Requirements	628
10.1.1.1	Smart Battery Charger	628
10.1.1.2	Smart Battery Charger with optional System Manager or Selector	629
10.1.1.3	Smart Battery System Manager	629
10.1.1.4	Smart Battery Selector	629
10.1.2	Smart Battery Objects	629
10.1.3	_SBS (Smart Battery Subsystem)	630
10.1.3.1	Example: Single Smart Battery Subsystem	630
10.1.3.2	Multiple Smart Battery Subsystem: Example	631
10.2	Control Method Batteries	633
10.2.1	Battery Events	633
10.2.2	Battery Control Methods	634
10.2.2.1	_BCT (Battery Charge Time)	635
10.2.2.2	_BIF (Battery Information)	635

10.2.2.3	_BIX (Battery Information Extended)	637
10.2.2.4	_BMA (Battery Measurement Averaging Interval)	640
10.2.2.5	_BMC (Battery Maintenance Control)	641
10.2.2.6	_BMD (Battery Maintenance Data)	642
10.2.2.7	_BMS (Battery Measurement Sampling Time)	645
10.2.2.8	_BPC (Battery Power Characteristics)	645
10.2.2.9	_BPS (Battery Power State)	646
10.2.2.10	_BPT (Battery Power Threshold)	647
10.2.2.11	_BST (Battery Status)	648
10.2.2.12	_BTH (Battery Throttle Limit)	650
10.2.2.13	_BTM (Battery Time)	651
10.2.2.14	_BTP (Battery Trip Point)	651
10.2.2.15	_OSC Definition for Control Method Battery	652
10.3	AC Adapters and Power Source Objects	652
10.3.1	_PSR (Power Source)	653
10.3.2	_PCL (Power Consumer List)	653
10.3.3	_PIF (Power Source Information)	653
10.3.4	_PRL (Power Source Redundancy List)	654
10.4	Power Meters	655
10.4.1	_PMC (Power Meter Capabilities)	655
10.4.2	_PTP (Power Trip Points)	657
10.4.3	_PMM (Power Meter Measurement)	658
10.4.4	_PAI (Power Averaging Interval)	658
10.4.5	_GAI (Get Averaging Interval)	658
10.4.6	_SHL (Set Hardware Limit)	659
10.4.7	_GHL (Get Hardware Limit)	659
10.4.8	_PMD (Power Metered Devices)	659
10.5	Wireless Power Controllers	660
10.5.1	Wireless Power Calibration Device	661
10.5.2	Wireless Power Calibration (_WPC)	661
10.5.3	Wireless Power Polling (_WPP)	661
10.6	Wireless Power Calibration Event	661
10.7	Example: Power Source and Power Meter Namespace	662
11	Thermal Management	663
11.1	Thermal Control	663
11.1.1	Active, Passive, and Critical Policies	664
11.1.2	Dynamically Changing Cooling Temperature Trip Points	665
11.1.2.1	OSPM Change of Cooling Policy	665
11.1.2.2	Resetting Cooling Temperatures to Adjust to Bay Device Insertion or Removal	666
11.1.2.3	Resetting Cooling Temperatures to Implement Hysteresis	666
11.1.3	Detecting Temperature Changes	666
11.1.3.1	Temperature Change Notifications	667
11.1.3.2	Polling	668
11.1.4	Active Cooling	668
11.1.5	Passive Cooling	668
11.1.5.1	Processor Clock Throttling	669
11.1.6	Critical Shutdown	670
11.2	Cooling Preferences	671
11.2.1	Evaluating Thermal Device Lists	672
11.2.2	Evaluating Device Thermal Relationship Information	672
11.2.3	Fan Device Notifications	673
11.3	Fan Device	673
11.3.1	Fan Objects	673

11.3.1.1	_FIF (Fan Information)	673
11.3.1.2	_FPS (Fan Performance States)	674
11.3.1.3	_FSL (Fan Set Level)	676
11.3.1.4	_FST (Fan Status)	676
11.4	Thermal Objects	677
11.4.1	_ACx (Active Cooling)	677
11.4.2	_ALx (Active List)	678
11.4.3	_ART (Active Cooling Relationship Table)	678
11.4.4	_CRT (Critical Temperature)	681
11.4.5	_CR3 (Warm/Standby Temperature)	681
11.4.6	_DTI (Device Temperature Indication)	681
11.4.7	_HOT (Hot Temperature)	682
11.4.8	_MTL (Minimum Throttle Limit)	682
11.4.9	_NTT (Notification Temperature Threshold)	682
11.4.10	_PSL (Passive List)	683
11.4.11	_PSV (Passive)	683
11.4.12	_RTV (Relative Temperature Values)	683
11.4.13	_SCP (Set Cooling Policy)	684
11.4.14	_STR (String)	687
11.4.15	_TC1 (Thermal Constant 1)	687
11.4.16	_TC2 (Thermal Constant 2)	687
11.4.17	_TFP (Thermal fast Sampling Period)	687
11.4.18	_TMP (Temperature)	688
11.4.19	_TPT (Trip Point Temperature)	688
11.4.20	_TRT (Thermal Relationship Table)	688
11.4.21	_TSN (Thermal Sensor Device)	689
11.4.22	_TSP (Thermal Sampling Period)	690
11.4.23	_TST (Temperature Sensor Threshold)	690
11.4.24	_TZD (Thermal Zone Devices)	690
11.4.25	_TZM (Thermal Zone Member)	691
11.4.26	_TZP (Thermal Zone Polling)	691
11.5	Native OS Device Driver Thermal Interfaces	691
11.6	Thermal Zone Interface Requirements	692
11.7	Thermal Zone Examples	693
11.7.1	Example: The Basic Thermal Zone	693
11.7.2	Example: Multiple-Speed Fans	694
11.7.3	Example: Thermal Zone with Multiple Devices	696
12	ACPI Embedded Controller Interface Specification	701
12.1	Embedded Controller Interface Description	702
12.2	Embedded Controller Register Descriptions	704
12.2.1	Embedded Controller Status, EC_SC (R)	705
12.2.2	Embedded Controller Command, EC_SC (W)	706
12.2.3	Embedded Controller Data, EC_DATA (R/W)	706
12.3	Embedded Controller Command Set	706
12.3.1	Read Embedded Controller, RD_EC (0x80)	706
12.3.2	Write Embedded Controller, WR_EC (0x81)	706
12.3.3	Burst Enable Embedded Controller, BE_EC (0x82)	707
12.3.4	Burst Disable Embedded Controller, BD_EC (0x83)	707
12.3.5	Query Embedded Controller, QR_EC (0x84)	707
12.4	SMBus Host Controller Notification Header (Optional), OS_SMB_EVT	708
12.5	Embedded Controller Firmware	708
12.6	Interrupt Model	708
12.6.1	Event Interrupt Model	709

12.6.2	Command Interrupt Model	709
12.7	Embedded Controller Interfacing Algorithms	710
12.8	Embedded Controller Description Information	710
12.9	SMBus Host Controller Interface via Embedded Controller	711
12.9.1	Register Description	711
12.9.1.1	Status Register, SMB_STS	711
12.9.1.2	Protocol Register, SMB_PRTCL	712
12.9.1.3	Address Register, SMB_ADDR	713
12.9.1.4	Command Register, SMB_CMD	713
12.9.1.5	Data Register Array, SMB_DATA[i], i=0-31	714
12.9.1.6	Block Count Register, SMB_BCNT	714
12.9.1.7	Alarm Address Register, SMB_ALRM_ADDR	714
12.9.1.8	Alarm Data Registers, SMB_ALRM_DATA[0], SMB_ALRM_DATA[1]	715
12.9.2	Protocol Description	715
12.9.2.1	Write Quick	715
12.9.2.2	Read Quick	715
12.9.2.3	Send Byte	716
12.9.2.4	Receive Byte	716
12.9.2.5	Write Byte	716
12.9.2.6	Read Byte	717
12.9.2.7	Write Word	717
12.9.2.8	Read Word	717
12.9.2.9	Write Block	718
12.9.2.10	Read Block	718
12.9.2.11	Process Call	718
12.9.2.12	Block Write-Block Read Process Call	719
12.9.2.13	SMBus Register Set	719
12.10	SMBus Devices	720
12.10.1	SMBus Device Access Restrictions	720
12.10.2	SMBus Device Command Access Restriction	721
12.11	Defining an Embedded Controller Device in ACPI Namespace	721
12.11.1	Example: EC Definition ASL Code	723
12.12	Defining an EC SMBus Host Controller in ACPI Namespace	723
12.12.1	Example: EC SMBus Host Controller ASL-Code	724
13	ACPI System Management Bus Interface Specification	725
13.1	SMBus Overview	725
13.1.1	SMBus Slave Addresses	725
13.1.2	SMBus Protocols	726
13.1.3	SMBus Status Codes	726
13.1.4	SMBus Command Values	727
13.2	Accessing the SMBus from ASL Code	727
13.2.1	Declaring SMBus Host Controller Objects	727
13.2.2	Declaring SMBus Devices	728
13.2.3	Declaring SMBus Operation Regions	728
13.2.4	Declaring SMBus Fields	729
13.2.5	Declaring and Using an SMBus Data Buffer	731
13.3	Using the SMBus Protocols	733
13.3.1	Read/Write Quick (SMBQuick)	733
13.3.2	Send/Receive Byte (SMBSendReceive)	733
13.3.3	Read/Write Byte (SMBByte)	734
13.3.4	Read/Write Word (SMBWord)	735
13.3.5	Read/Write Block (SMBBlock)	735
13.3.6	Word Process Call (SMBProcessCall)	736

13.3.7	Block Process Call (SMBBlockProcessCall)	737
14	Platform Communications Channel (PCC)	738
14.1	Platform Communications Channel Table	738
14.1.1	Platform Communications Channel Global Flags	739
14.1.2	Platform Communications Channel Subspace Structures	739
14.1.3	Generic Communications Subspace Structure (type 0)	740
14.1.4	HW-Reduced Communications Subspace Structure (type 1)	740
14.1.5	HW-Reduced Communications Subspace Structure (type 2)	742
14.1.6	Extended PCC subspaces (types 3 and 4)	743
14.1.7	HW Registers based Communications Subspace Structure (Type 5)	745
14.2	Generic Communications Channel Shared Memory Region	747
14.2.1	Generic Communications Channel Command Field	747
14.2.2	Generic Communications Channel Status Field	747
14.3	Extended PCC Subspace Shared Memory Region	748
14.4	Reduced PCC Subspace Shared Memory Region	749
14.5	Doorbell Protocol	749
14.6	Platform Notification	751
14.6.1	Platform Notification for Subspace Types 0, 1 and 2	751
14.6.2	Platform Notification for Responder PCC subspaces (type 4)	752
14.7	Referencing the PCC address space	753
15	System Address Map Interfaces	754
15.1	INT 15H, E820H - Query System Address Map	756
15.2	E820 Assumptions and Limitations	757
15.3	UEFI GetMemoryMap() Boot Services Function	758
15.4	UEFI Assumptions and Limitations	759
15.5	Example Address Map	760
15.6	Example: Operating System Usage	761
16	Waking and Sleeping	762
16.1	Sleeping States	763
16.1.1	S1 Sleeping State	765
16.1.1.1	Example 1: S1 Sleeping State Implementation	765
16.1.1.2	Example 2: S1 Sleeping State Implementation	766
16.1.2	S2 Sleeping State	766
16.1.2.1	Example: S2 Sleeping State Implementation	766
16.1.3	S3 Sleeping State	767
16.1.3.1	Example: S3 Sleeping State Implementation	767
16.1.4	S4 Sleeping State	767
16.1.4.1	Operating System-Initiated S4 Transition	768
16.1.4.2	The S4BIOS Transition	768
16.1.5	S5 Soft Off State	769
16.1.6	Transitioning from the Working to the Sleeping State	769
16.1.7	Transitioning from the Working to the Soft Off State	770
16.2	Flushing Caches	770
16.3	Initialization	771
16.3.1	Placing the System in ACPI Mode	773
16.3.2	Platform Boot Firmware Initialization of Memory	773
16.3.3	OS Loading	776
16.3.4	Exiting ACPI Mode	776
17	Non-Uniform Memory Access (NUMA) Architecture Platforms	778
17.1	NUMA Node	778
17.2	System Locality	779

17.2.1	System Resource Affinity Table Definition	779
17.2.2	System Resource Affinity Update	779
17.3	System Locality Distance Information	779
17.3.1	Online Hot Plug	780
17.3.2	Impact to Existing Localities	780
17.4	Heterogeneous Memory Attributes Information	780
17.4.1	Online Hot Plug	781
17.4.2	Impact to Existing Localities	781
18	ACPI Platform Error Interfaces (APEI)	782
18.1	Hardware Errors and Error Sources	782
18.2	Relationship between OSPM and System Firmware	783
18.3	Error Source Discovery	783
18.3.1	Boot Error Source	783
18.3.2	ACPI Error Source	784
18.3.2.1	IA-32 Architecture Machine Check Exception	785
18.3.2.2	IA-32 Architecture Corrected Machine Check	787
18.3.2.3	IA-32 Architecture Non-Maskable Interrupt	788
18.3.2.4	PCI Express Root Port AER Structure	788
18.3.2.5	PCI Express Device AER Structure	790
18.3.2.6	PCI Express/PCI-X Bridge AER Structure	791
18.3.2.7	Generic Hardware Error Source	793
18.3.2.8	Generic Hardware Error Source version 2 (GHESv2 - Type 10)	797
18.3.2.9	Hardware Error Notification	799
18.3.2.10	IA-32 Architecture Deferred Machine Check	800
18.3.2.11	Error Source Structure Header (Type 12 Onward)	801
18.4	Firmware First Error Handling	801
18.4.1	Example: Firmware First Handling Using NMI Notification	802
18.5	Error Serialization	802
18.5.1	Serialization Action Table	803
18.5.1.1	Serialization Actions	803
18.5.1.2	Serialization Instruction Entries	805
18.5.1.3	Error Record Serialization Information	808
18.5.2	Operations	809
18.5.2.1	Writing	809
18.5.2.2	Reading	810
18.5.2.3	Clearing	811
18.5.2.4	Usage	812
18.6	Error Injection	813
18.6.1	Error Injection Table (EINJ)	813
18.6.2	Injection Instruction Entries	815
18.6.3	Injection Instructions	816
18.6.4	Error Types	817
18.6.4.1	EINJv2 Error Types	819
18.6.5	Trigger Action Table	822
18.6.6	Error Injection Operation	822
18.6.7	Error Injection Version 2 Operation	823
18.7	GHES_ASSIST Error Reporting	825
18.7.1	GHES_ASSIST on Machine Check Architecture	825
19	ACPI Source Language (ASL) Reference	826
19.1	ASL 2.0 Symbolic Operators and Expressions	826
19.2	ASL Language Grammar	828
19.2.1	ASL Grammar Notation	828

19.2.2	ASL Name and Pathname Terms	829
19.2.3	ASL Root and Secondary Terms	830
19.2.4	ASL Data and Constant Terms	831
19.2.5	ASL Opcode Terms	832
19.2.6	ASL Primary (Terminal) Terms	834
19.2.7	ASL Parameter Keyword Terms	851
19.2.8	ASL Resource Template Terms	852
19.3	ASL Concepts	862
19.3.1	ASL Names	862
19.3.1.1	_T_x Reserved Object Names	863
19.3.2	ASL Literal Constants	863
19.3.2.1	Integers	863
19.3.2.2	Strings	863
19.3.3	ASL Resource Templates	865
19.3.4	ASL Macros	866
19.3.5	ASL Data Types	867
19.3.5.1	Data Type Conversion Overview	868
19.3.5.2	Explicit Data Type Conversions	868
19.3.5.3	Implicit Data Type Conversions	869
19.3.5.4	Implicit Source Operand Conversion	869
19.3.5.5	Implicit Result Object Conversion	870
19.3.5.6	Data Types and Type Conversions	871
19.3.5.7	Data Type Conversion Rules	871
19.3.5.8	Rules for Storing and Copying Objects	874
19.4	ASL Operators Summary	877
19.5	ASL Operator Summary by Type	880
19.6	ASL Operator Reference	884
19.6.1	AccessAs (Change Field Unit Access)	885
19.6.2	Acquire (Acquire a Mutex)	886
19.6.3	Add (Integer Add)	886
19.6.4	Alias (Declare Name Alias)	886
19.6.5	And (Integer Bitwise And)	887
19.6.6	Argx (Method Argument Data Objects)	887
19.6.7	BankField (Declare Bank/Data Field)	887
19.6.8	Break (Break from While)	888
19.6.9	BreakPoint (Execution Break Point)	889
19.6.10	Buffer (Declare Buffer Object)	889
19.6.11	Case (Expression for Conditional Execution)	890
19.6.12	Concatenate (Concatenate Data)	890
19.6.13	ConcatenateResTemplate (Concatenate Resource Templates)	891
19.6.14	CondRefOf (Create Object Reference Conditionally)	892
19.6.15	Connection (Declare Field Connection Attributes)	892
19.6.16	Continue (Continue Innermost Enclosing While)	893
19.6.17	CopyObject (Copy and Store Object)	893
19.6.18	CreateBitField (Create 1-Bit Buffer Field)	893
19.6.19	CreateByteField (Create 8-Bit Buffer Field)	894
19.6.20	CreateDWordField (Create 32-Bit Buffer Field)	894
19.6.21	CreateField (Create Arbitrary Length Buffer Field)	894
19.6.22	CreateQWordField (Create 64-Bit Buffer Field)	895
19.6.23	CreateWordField (Create 16-Bit Buffer Field)	895
19.6.24	CSI2Bus (CSI-2 Serial Bus Connection Resource Descriptor Macro)	895
19.6.25	DataTableRegion (Create Data Table Operation Region)	896
19.6.26	Debug (Debugger Output)	896
19.6.27	Decrement (Integer Decrement)	897

19.6.28	Default (Default Execution Path in Switch)	897
19.6.29	DefinitionBlock (Declare Definition Block)	897
19.6.30	DerefOf (Dereference an Object Reference)	898
19.6.31	Device (Declare Device Package)	898
19.6.32	Divide (Integer Divide)	899
19.6.33	DMA (DMA Resource Descriptor Macro)	900
19.6.34	DWordIO (DWord IO Resource Descriptor Macro)	900
19.6.35	DWordMemory (DWord Memory Resource Descriptor Macro)	902
19.6.36	DWordSpace (DWord Space Resource Descriptor Macro)	903
19.6.37	EISAID (EISA ID String To Integer Conversion Macro)	905
19.6.38	Else (Alternate Execution)	905
19.6.39	ElseIf (Alternate/Conditional Execution)	906
19.6.40	EndDependentFn (End Dependent Function Resource Descriptor Macro)	907
19.6.41	Event (Declare Event Synchronization Object)	907
19.6.42	ExtendedIO (Extended IO Resource Descriptor Macro)	907
19.6.43	ExtendedMemory (Extended Memory Resource Descriptor Macro)	908
19.6.44	ExtendedSpace (Extended Address Space Resource Descriptor Macro)	910
19.6.45	External (Declare External Objects)	911
19.6.46	Fatal (Fatal Error Check)	912
19.6.47	Field (Declare Field Objects)	912
19.6.48	FindSetLeftBit (Find First Set Left Bit)	914
19.6.49	FindSetRightBit (Find First Set Right Bit)	914
19.6.50	FixedDMA (DMA Resource Descriptor Macro)	915
19.6.51	FixedIO (Fixed IO Resource Descriptor Macro)	915
19.6.52	For (Conditional Loop)	916
19.6.53	Fprintf (Create and Store formatted string)	916
19.6.54	FromBCD (Convert BCD To Integer)	917
19.6.55	Function (Declare Control Method)	917
19.6.56	GpioInt (GPIO Interrupt Connection Resource Descriptor Macro)	918
19.6.57	GpioIo (GPIO Connection IO Resource Descriptor Macro)	919
19.6.58	I2CSerialBusV2 (I2C Serial Bus Connection Resource Descriptor (Version 2) Macro)	920
19.6.59	If (Conditional Execution)	921
19.6.60	Include (Include Additional ASL File)	921
19.6.61	Increment (Integer Increment)	922
19.6.62	Index (Indexed Reference To Member Object)	922
19.6.62.1	Index with Packages	922
19.6.62.2	Index with Buffers	923
19.6.62.3	Index with Strings	924
19.6.63	IndexField (Declare Index/Data Fields)	924
19.6.64	Interrupt (Interrupt Resource Descriptor Macro)	925
19.6.65	IO (IO Resource Descriptor Macro)	927
19.6.66	IRQ (Interrupt Resource Descriptor Macro)	928
19.6.67	IRQNoFlags (Interrupt Resource Descriptor Macro)	928
19.6.68	LAnd (Logical And)	929
19.6.69	LEqual (Logical Equal)	929
19.6.70	LGreater (Logical Greater)	929
19.6.71	LGreaterEqual (Logical Greater Than Or Equal)	930
19.6.72	LLess (Logical Less)	930
19.6.73	LLessEqual (Logical Less Than Or Equal)	930
19.6.74	LNot (Logical Not)	931
19.6.75	LNotEqual (Logical Not Equal)	931
19.6.76	Load (Load Definition Block)	931
19.6.77	LoadTable (Load Definition Block From XSDT)	932
19.6.78	Localx (Method Local Data Objects)	933

19.6.79 LOr (Logical Or)	933
19.6.80 Match (Find Object Match)	933
19.6.81 Memory24 (Memory Resource Descriptor Macro)	934
19.6.82 Memory32 (Memory Resource Descriptor Macro)	935
19.6.83 Memory32Fixed (Memory Resource Descriptor Macro)	936
19.6.84 Method (Declare Control Method)	936
19.6.85 Mid (Extract Portion of Buffer or String)	938
19.6.86 Mod (Integer Modulo)	938
19.6.87 Multiply (Integer Multiply)	938
19.6.88 Mutex (Declare Synchronization/Mutex Object)	939
19.6.89 Name (Declare Named Object)	939
19.6.90 NAnd (Integer Bitwise Nand)	940
19.6.91 NoOp Code (No Operation)	940
19.6.92 NOr (Integer Bitwise Nor)	940
19.6.93 Not (Integer Bitwise Not)	940
19.6.94 Notify (Notify Object of Event)	941
19.6.95 Offset (Change Current Field Unit Offset)	941
19.6.96 ObjectType (Get Object Type)	941
19.6.97 One (Constant One Integer)	942
19.6.98 Ones (Constant Ones Integer)	942
19.6.99 OperationRegion (Declare Operation Region)	943
19.6.100Or (Integer Bitwise Or)	944
19.6.101Package (Declare Package Object)	944
19.6.102PinConfig (Pin Configuration Descriptor Macro)	946
19.6.103PinFunction (Pin Function Descriptor Macro)	949
19.6.104PinGroup (Pin Group Descriptor Macro)	952
19.6.105PinGroupConfig (Pin Group Configuration Descriptor Macro)	952
19.6.106PinGroupFunction (Pin Group Function Configuration Descriptor Macro)	956
19.6.107PowerResource (Declare Power Resource)	957
19.6.108Printf (Create and Store formatted string)	957
19.6.109QWordIO (QWord IO Resource Descriptor Macro)	958
19.6.110QWordMemory (QWord Memory Resource Descriptor Macro)	959
19.6.111QWordSpace (QWord Space Resource Descriptor Macro)	961
19.6.112RawDataBuffer (Raw Data Buffer)	962
19.6.113RefOf (Create Object Reference)	962
19.6.114Register (Generic Register Resource Descriptor Macro)	963
19.6.115Release (Release a Mutex Synchronization Object)	964
19.6.116Reset (Reset an Event Synchronization Object)	964
19.6.117ResourceTemplate (Resource To Buffer Conversion Macro)	964
19.6.118Return (Return from Method Execution)	965
19.6.119Revision (Constant Revision Integer)	965
19.6.120Scope (Open Named Scope)	965
19.6.121ShiftLeft (Integer Shift Left)	966
19.6.122ShiftRight (Integer Shift Right)	967
19.6.123Signal (Signal a Synchronization Event)	967
19.6.124SizeOf (Get Data Object Size)	967
19.6.125Sleep (Milliseconds Sleep)	968
19.6.126SPISerialBusV2 (SPI Serial Bus Connection Resource Descriptor (Version 2) Macro)	968
19.6.127Stall (Stall for a Short Time)	969
19.6.128StartDependentFn (Start Dependent Function Resource Descriptor Macro)	969
19.6.129StartDependentFnNoPri (Start Dependent Function Resource Descriptor Macro)	970
19.6.130Store (Store an Object)	970
19.6.131Subtract (Integer Subtract)	971
19.6.132Switch (Select Code To Execute Based On Expression)	971

19.6.133	ThermalZone (Declare Thermal Zone)	973
19.6.134	Timer (Get 64-Bit Timer Value)	973
19.6.135	ToBCD (Convert Integer to BCD)	974
19.6.136	ToBuffer (Convert Data to Buffer)	974
19.6.137	ToDecimalString (Convert Data to Decimal String)	974
19.6.138	ToHexString (Convert Data to Hexadecimal String)	975
19.6.139	ToInteger (Convert Data to Integer)	975
19.6.140	ToPLD (Creates a _PLD Buffer Object)	975
19.6.141	ToString (Convert Buffer To String)	977
19.6.142	ToUUID (Convert String to UUID Macro)	977
19.6.143	UARTSerialBusV2 (UART Serial Bus Connection Resource Descriptor Version 2 Macro)	978
19.6.144	Unicode (String To Unicode Conversion Macro)	980
19.6.145	VendorLong (Long Vendor Resource Descriptor)	980
19.6.146	VendorShort (Short Vendor Resource Descriptor)	980
19.6.147	Wait (Wait for a Synchronization Event)	981
19.6.148	While (Conditional Loop)	981
19.6.149	WordBusNumber (Word Bus Number Resource Descriptor Macro)	981
19.6.150	WordIO (Word IO Resource Descriptor Macro)	982
19.6.151	WordSpace (Word Space Resource Descriptor Macro)	984
19.6.152	XOr (Integer Bitwise Xor)	985
19.6.153	Zero (Constant Zero Integer)	985
19.6.154	ClockInput (Clock Input Resource Descriptor Macro)	986
20	ACPI Machine Language (AML) Specification	987
20.1	Notation Conventions	987
20.2	AML Grammar Definition	988
20.2.1	Table and Table Header Encoding	988
20.2.2	Name Objects Encoding	989
20.2.3	Data Objects Encoding	990
20.2.4	Package Length Encoding	991
20.2.5	Term Objects Encoding	991
20.2.5.1	Namespace Modifier Objects Encoding	991
20.2.5.2	Named Objects Encoding	992
20.2.5.3	Statement Opcodes Encoding	995
20.2.5.4	Expression Opcodes Encoding	996
20.2.6	Miscellaneous Objects Encoding	1000
20.2.6.1	Arg Objects Encoding	1000
20.2.6.2	Local Objects Encoding	1000
20.2.6.3	Debug Objects Encoding	1001
20.3	AML Byte Stream Byte Values	1001
20.4	AML Encoding of Names in the Namespace	1004
21	ACPI Data Tables and Table Definition Language	1006
21.1	Types of ACPI Data Tables	1006
21.2	ACPI Table Definition Language Specification	1007
21.2.1	Overview of the Table Definition Language (TDL)	1007
21.2.2	TDL Grammar Specification	1008
21.2.3	Data Types	1009
21.2.3.1	Integers	1009
21.2.3.2	Integer Expressions	1010
21.2.3.3	Flags	1010
21.2.3.4	Strings	1011
21.2.3.5	Buffers	1011
21.2.4	Fields Set Automatically by the Compiler	1011

21.2.5	Special Fields	1012
21.2.6	TDL Generic Data Types	1012
21.2.7	Defining a Known ACPI Table in TDL	1012
21.2.8	Defining an Unknown or New ACPI table in TDL	1013
21.2.9	Table Definition Language Examples	1013
21.2.9.1	ECDT Disassembler Output	1013
21.2.9.2	ECDT Definition with Field Comments	1014
21.2.10	Minimal ECDT Definition	1015
21.2.10.1	Generic ACPI Table Definition	1015
A	Appendix A: Device Class Specifications	1016
A.1	Overview	1016
A.2	Device Power States	1016
A.2.1	Bus Power Management	1017
A.2.2	Display Power Management	1017
A.2.3	PCMCIA/PCCARD/CardBus Power Management	1017
A.2.4	PCI Power Management	1018
A.2.5	USB Power Management	1018
A.2.6	Device Classes	1018
A.3	Default Device Class	1019
A.3.1	Default Power Management Policy	1019
A.3.2	Default Wake Events	1019
A.3.3	Default Minimum Power Capabilities	1019
A.4	Audio Device Class	1020
A.4.1	Audio Device Power State Definitions	1020
A.4.2	Audio Device Power Management Policy	1020
A.4.3	Audio Device Wake Events	1021
A.4.4	Audio Device Minimum Power Capabilities	1021
A.5	COM Port Device Class	1021
A.5.1	COM Port Power State Definitions	1022
A.5.2	COM Power Power Management Policy	1022
A.5.3	COM Port Wake Events	1022
A.5.4	COM Port Minimum Power Capabilities	1022
A.6	Display Device Class	1023
A.6.1	Display Device Power State Definitions	1023
A.6.1.1	Display Codecs	1026
A.6.2	Display Device Power Management Policy	1026
A.6.3	Display Device Wake Events	1027
A.6.4	Display Device Minimum Power Capabilities	1027
A.6.5	Display Device Performance States	1027
A.6.5.1	Common Requirements for Display Class Performance States	1027
A.6.5.2	Performance states for Full Screen Displays	1027
A.6.5.3	Performance States for Video Controllers/Display Adapters	1028
A.7	Input Device Class	1028
A.7.1	Input Device Power State Definitions	1029
A.7.2	Input Device Power Management Policy	1029
A.7.3	Input Device Wake Events	1029
A.7.4	Input Device Minimum Power Capabilities	1030
A.8	Modem Device Class	1030
A.8.1	Technology Overview	1030
A.8.1.1	Traditional Connections	1031
A.8.1.2	Power-Managed Connections	1031
A.8.1.3	Motherboard Modems	1031
A.8.2	Modem Device Power State Definitions	1031

A.8.3	Modem Device Power Management Policy	1032
A.8.4	Modem Device Wake Events	1032
A.8.5	Modem Device Minimum Power Capabilities	1032
A.9	Network Device Class	1032
A.9.1	Network Device Power State Definitions	1032
A.9.2	Network Device Power Management Policy	1033
A.9.3	Network Device Wake Events	1033
A.9.3.1	Link Status Events	1033
A.9.3.2	Wake Frame Events	1034
A.9.4	Network Device Minimum Power Capabilities	1034
A.10	PC Card Controller Device Class	1034
A.10.1	PC Card Controller Device Power State Definitions	1034
A.10.2	PC Card Controller Device Power Management Policy	1035
A.10.3	PC Card Controller Wake Events	1036
A.10.4	PC Card Controller Minimum Power Capabilities	1036
A.11	Storage Device Class	1036
A.11.1	Storage Device Power State Definitions	1036
A.11.2	Storage Device Power Management Policy	1037
A.11.3	Storage Device Wake Events	1038
A.11.4	Storage Device Minimum Power Capabilities	1038
B	Appendix B: Video Extensions	1039
B.1	ACPI Extensions for Display Adapters: Introduction	1039
B.2	Video Extension Definitions	1040
B.3	ACPI Namespace	1040
B.4	Display-specific Methods	1041
B.4.1	_DOS (Enable/Disable Output Switching)	1041
B.4.2	_DOD (Enumerate All Devices Attached to the Display Adapter)	1042
B.4.3	_ROM (Get ROM Data)	1045
B.4.4	_GPD (Get POST Device)	1046
B.4.5	_SPD (Set POST Device)	1046
B.4.6	_VPO (Video POST Options)	1047
B.5	Notifications for Display Devices	1047
B.6	Output Device-specific Methods	1048
B.6.1	_ADR (Return the Unique ID for this Device)	1048
B.6.2	_BCL (Query List of Brightness Control Levels Supported)	1048
B.6.3	_BCM (Set the Brightness Level)	1049
B.6.4	_BQC (Brightness Query Current level)	1049
B.6.5	_DDC (Return the EDID for this Device)	1049
B.6.6	_DCS (Return the Status of Output Device)	1050
B.6.7	_DGS (Query Graphics State)	1051
B.6.8	_DSS (Device Set State)	1051
B.7	Notifications Specific to Output Devices	1052
B.8	Notes on State Changes	1053
C	Appendix C: Deprecated Content	1054
	Index	1056

Acknowledgments

The material contained herein is not a license, either expressly or impliedly, to any intellectual property owned or controlled by any of the authors or developers of this material or to any contribution thereto. The material contained herein is provided on an “AS IS” basis and, to the maximum extent permitted by applicable law, this information is provided AS IS AND WITH ALL FAULTS, and the authors and developers of this material hereby disclaim all other warranties and conditions, either express, implied or statutory, including, but not limited to, any (if any) implied warranties, duties or conditions of merchantability, of fitness for a particular purpose, of accuracy or completeness of responses, of results, of workmanlike effort, of lack of viruses and of lack of negligence, all with regard to this material and any contribution thereto. Designers must not rely on the absence or characteristics of any features or instructions marked “reserved” or “undefined.” The Unified EFI Forum, Inc. reserves any features or instructions so marked for future definition and shall have no responsibility whatsoever for conflicts or incompatibilities arising from future changes to them. ALSO, THERE IS NO WARRANTY OR CONDITION OF TITLE, QUIET ENJOYMENT, QUIET POSSESSION, CORRESPONDENCE TO DESCRIPTION OR NON-INFRINGEMENT WITH REGARD TO THE SPECIFICATION AND ANY CONTRIBUTION THERETO.

IN NO EVENT WILL ANY AUTHOR OR DEVELOPER OF THIS MATERIAL OR ANY CONTRIBUTION THERETO BE LIABLE TO ANY OTHER PARTY FOR THE COST OF PROCURING SUBSTITUTE GOODS OR SERVICES, LOST PROFITS, LOSS OF USE, LOSS OF DATA, OR ANY INCIDENTAL, CONSEQUENTIAL, DIRECT, INDIRECT, OR SPECIAL DAMAGES WHETHER UNDER CONTRACT, TORT, WARRANTY, OR OTHERWISE, ARISING IN ANY WAY OUT OF THIS OR ANY OTHER AGREEMENT RELATING TO THIS DOCUMENT, WHETHER OR NOT SUCH PARTY HAD ADVANCE NOTICE OF THE POSSIBILITY OF SUCH DAMAGES.

Copyright © 2022, Unified Extensible Firmware Interface (UEFI) Forum, Inc. All Rights Reserved. The UEFI Forum is the owner of all rights and title in and to this work, including all copyright rights that may exist, and all rights to use and reproduce this work. Further to such rights, permission is hereby granted to any person implementing this specification to maintain an electronic version of this work accessible by its internal personnel, and to print a copy of this specification in hard copy form, in whole or in part, in each case solely for use by that person in connection with the implementation of this Specification, provided no modification is made to the Specification.

List of Tables

- Table 1.1 *Hardware Type vs. OS Type Interaction*
- Table 2.1 *Summary of Global Power States*
- Table 2.2 *Summary of Device Power States*
- Table 3.1 *Low Battery Levels*
- Table 3.3 *Implementable Platform Types*
- Table 4.1 *Feature-Programming Model Summary*
- Table 4.2 *PM1 Event Registers*
- Table 4.3 *PM1 Control Registers*
- Table 4.4 *PM2 Control Register*
- Table 4.5 *PM Timer Register*
- Table 4.6 *Processor Control Registers*
- Table 4.7 *General-Purpose Event Registers*
- Table 4.8 *Power Button Support*
- Table 4.9 *Sleep Button Support*
- Table 4.10 *Alarm Field Decodings within the FADT*
- Table 4.11 *PM1 Status Registers Fixed Hardware Feature Status Bits*
- Table 4.12 *PM1 Enable Registers Fixed Hardware Feature Enable Bits*
- Table 4.13 *PM1 Control Registers Fixed Hardware Feature Control Bits*
- Table 4.14 *PM Timer Bits*
- Table 4.15 *PM2 Control Register Bits*
- Table 4.16 *Processor Control Register Bits*
- Table 4.17 *Processor LVL2 Register Bits*
- Table 4.18 *Processor LVL3 Register Bits*
- Table 4.19 *Sleep Control Register*
- Table 4.20 *Sleep Status Register*
- Table 5.1 *Generic Address Structure (GAS)*
- Table 5.2 *Address Space Format*
- Table 5.3 *RSDP Structure*
- Table 5.4 *DESCRIPTION_HEADER Fields*
- Table 5.5 *DESCRIPTION_HEADER Signatures for tables defined by ACPI*
- Table 5.6 *DESCRIPTION_HEADER Signatures for tables reserved by ACPI*
- Table 5.7 *Root System Description Table Fields (RSDT)*
- Table 5.8 *Extended System Description Table Fields (XSDT)*
- Table 5.9 *FADT Format*
- Table 5.10 *Fixed ACPI Description Table Fixed Feature Flags*

- Table 5.11 *Fixed ACPI Description Table Boot IA-PC Boot*
- Table 5.12 *Fixed ACPI Description Table ARM Boot Architecture Flags*
- Table 5.13 *Firmware ACPI Control Structure (FACS)*
- Table 5.14 *Firmware Control Structure Feature Flags*
- Table 5.15 *OSPM Enabled Firmware Control Structure Feature Flags*
- Table 5.16 *Global Lock Structure within the FACS*
- Table 5.17 *Differentiated System Description Table Fields (DSDT)*
- Table 5.18 *Secondary System Description Table Fields (SSDT)*
- Table 5.19 *Multiple APIC Description Table (MADT) Format*
- Table 5.20 *Multiple APIC Flags*
- Table 5.21 *Interrupt Controller Structure Types*
- Table 5.22 *Processor Local APIC Structure*
- Table 5.23 *Local APIC Flags*
- Table 5.24 *I/O APIC Structure*
- Table 5.25 *Interrupt Source Override Structure*
- Table 5.26 *MPS INTI Flags*
- Table 5.27 *NMI Source Structure*
- Table 5.28 *Local APIC NMI Structure*
- Table 5.29 *Local APIC Address Override Structure*
- Table 5.30 *I/O SAPIC Structure*
- Table 5.31 *Processor Local SAPIC Structure*
- Table 5.32 *Platform Interrupt Source Structure*
- Table 5.33 *Platform Interrupt Source Flags*
- Table 5.34 *Processor Local x2APIC Structure*
- Table 5.35 *Local x2APIC NMI Structure*
- Table 5.36 *GICC Structure*
- Table 5.37 *GICC CPU Interface Flags*
- Table 5.38 *GICD Structure*
- Table 5.39 *GIC MSI Frame Structure*
- Table 5.40 *GIC MSI Frame Flags*
- Table 5.41 *GICR Structure*
- Table 5.42 *GIC ITS Structure*
- Table 5.43 *Multiprocessor Wakeup Structure*
- Table 5.44 *Multiprocessor Wakeup Mailbox Structure*
- Table 5.53 *Smart Battery Description Table (SBST) Format*
- Table 5.54 *Embedded Controller Boot Resources Table Format*

- *Table 5.55 Static Resource Affinity Table Format*
- *Table 5.56 Processor Local APIC/SAPIC Affinity Structure*
- *Table 5.57 Flags - Processor Local APIC/SAPIC Affinity Structure*
- *Table 5.58 Memory Affinity Structure*
- *Table 5.59 Flags - Memory Affinity Structure*
- *Table 5.60 Processor Local x2APIC Affinity Structure*
- *Table 5.61 GICC Affinity Structure*
- *Table 5.62 Flags - GICC Affinity Structure*
- *Table 5.63 Architecture Specific Affinity Structure*
- *Table 5.64 Generic Initiator Affinity Structure*
- *Table 5.65 Device Handle - ACPI*
- *Table 5.66 Device Handle - PCI*
- *Table 5.68 Flags - Generic Initiator/Port Affinity Structure*
- *Table 5.69 SLIT Format*
- *Table 5.70 Corrected Platform Error Polling Table Format*
- *Table 5.71 Corrected Platform Error Polling Processor Structure*
- *Table 5.72 Maximum System Characteristics Table (MSCT) Format*
- *Table 5.73 Maximum Proximity Domain Information Structure*
- *Table 5.74 RASF Table format*
- *Table 5.75 RASF Platform Communication Channel Shared Memory Region*
- *Table 5.76 PCC Command Codes used by RASF Platform Communication Channel*
- *Table 5.77 Platform RAS Capabilities Bitmap*
- *Table 5.78 Parameter Block Structure for PATROL_SCRUB*
- *Table 5.89 MPST Table Structure*
- *Table 5.90 PCC Command Codes used by MPST Platform Communication Channel*
- *Table 5.91 MPST Platform Communication Channel Shared Memory Region*
- *Table 5.92 Power State Values*
- *Table 5.93 Command Status*
- *Table 5.94 Memory Power Node Structure definition*
- *Table 5.95 Flag format*
- *Table 5.96 Memory Power State Structure definition*
- *Table 5.97 Memory Power State Characteristics Structure*
- *Table 5.98 Flag format of Memory Power State Characteristics Structure*
- *Table 5.99 Platform Memory Topology Table*
- *Table 5.100 Common Memory Device*
- *Table 5.101 Socket Type Data*

- Table 5.102 *Memory Controller Type Data*
- Table 5.103 *DIMM Type Specific Data*
- Table 5.104 *Vendor Specific Type Data*
- Table 5.105 *Boot Graphics Resource Table Fields*
- Table 5.106 *Firmware Performance Data Table (FPDT) Format*
- Table 5.107 *Performance Record Structure*
- Table 5.108 *FPDT Performance Record Types*
- Table 5.109 *Runtime Performance Record Types*
- Table 5.110 *Firmware Basic Boot Performance Table Pointer Record*
- Table 5.111 *S3 Performance Table Pointer Record*
- Table 5.112 *Firmware Basic Boot Performance Table Header*
- Table 5.113 *Firmware Basic Boot Performance Data Record*
- Table 5.114 *S3 Performance Table Header*
- Table 5.115 *Basic S3 Resume Performance Record*
- Table 5.116 *Basic S3 Suspend Performance Record*
- Table 5.117 *GTDT Table Structure*
- Table 5.118 *Flag Definitions: Secure EL1 Timer, Non-Secure EL1 Timer, EL2 Timer, Virtual EL1 Timer and Virtual EL2 Timer*
- Table 5.119 *Platform Timer Type Structures*
- Table 5.120 *GT Block Structure Format*
- Table 5.121 *GT Block Timer Structure Format*
- Table 5.122 *Flag Definitions: GT Block Physical Timers and Virtual Timers*
- Table 5.123 *Flag Definitions - Common Flags*
- Table 5.124 *Arm Generic Watchdog Structure Format*
- Table 5.125 *Flag Definitions - Arm Generic Watchdog Timer*
- Table 5.126 *NVDIMM Firmware Interface Table (NFIT)*
- Table 5.127 *NFIT Structure Types*
- Table 5.128 *SPA Range Structure*
- Table 5.129 *NVDIMM Region Mapping Structure*
- Table 5.130 *Interleave Structure Index and Interleave Ways definition*
- Table 5.131 *Interleave Structure*
- Table 5.132 *SMBIOS Management Information Structure*
- Table 5.133 *NVDIMM Control Region Structure Mark*
- Table 5.134 *NVDIMM Block Data Windows Region Structure*
- Table 5.135 *Flush Hint Address Structure*
- Table 5.136 *Platform Capabilities Structure*

- Table 5.137 *SDEV ACPI Table*
- Table 5.138 *Secure Device Structures*
- Table 5.139 *ACPI_NAMESPACE_DEVICE based Secure Device Structure*
- Table 5.140 *Secure Access Component Types*
- Table 5.141 *Identification Based Secure Access Component*
- Table 5.142 *Memory-based Secure Access Component*
- Table 5.143 *PCIe Endpoint Device-based Device Structure*
- Table 5.144 *PCIe Endpoint Device-based Device Structure Example*
- Table 5.145 *Heterogeneous Memory Attribute Table Header*
- Table 5.146 *HMAT Structure Types*
- Table 5.147 *Memory Proximity Domain Attributes Structure*
- Table 5.148 *System Locality Latency and Bandwidth Information Structure*
- Table 5.149 *Memory Side Cache Information Structure*
- Table 5.150 *PDTT Structure*
- Table 5.151 *PDTT Platform Communication Channel Identifier Structure*
- Table 5.152, *Type 5 Platform Communication Channel Shared Memory*
- Table 5.153 *PCC Commands Codes used by Platform Debug Trigger Table*
- Table 5.154 *PDTT Platform Communication Channel*
- Table 5.155 *Example: Platform with 4 debug triggers*
- Table 5.156 *Processor Properties Topology Table*
- Table 5.157 *Processor Hierarchy Node Structure*
- Table 5.158 *Processor Structure Flags*
- Table 5.159 *Cache Type Structure*
- Table 5.160 *Cache Structure Flags*
- Table 5.161 *Platform Health Assessment Table (PHAT) Format*
- Table 5.162 *Platform Health Assessment Record Format*
- Table 5.163 *Platform Health Assessment Record Type Format*
- Table 5.164 *PHAT Version Element*
- Table 5.165 *Firmware Version Data Record*
- Table 5.166 *Firmware Health Data Record Structure*
- Table 5.181 *Namespaces Defined Under the Namespace Root*
- Table 5.182 *Operation Region Address Space Identifiers*
- Table 5.183 *IPMI Status Codes*
- Table 5.184 *Accessor Type Values*
- Table 5.185 *ACPI Event Programming Model Components*
- Table 5.186 *Fixed ACPI Events*

- Table 5.187 *Device Object Notification Values*
- Table 5.188 *System Bus Notification Values*
- Table 5.189 *Control Method Battery Device Notification Values*
- Table 5.190 *Power Source Object Notification Values*
- Table 5.191 *Thermal Zone Object Notification Values*
- Table 5.192 *Control Method Power Button Notification Values*
- Table 5.193 *Control Method Sleep Button Notification Values*
- Table 5.194 *Control Method Lid Notification Values*
- Table 5.195 *NVDIMM Root Device Notification Values*
- Table 5.196 *NVDIMM Device Notification Values*
- Table 5.197 *Processor Device Notification Values*
- Table 5.198 *User Presence Device Notification Values*
- Table 5.199 *Ambient Light Sensor Device Notification Values*
- Table 5.200 *Power Meter Object Notification Values*
- Table 5.201 *Processor Aggregator Device Notification Values*
- Table 5.202 *Error Device Notification Values*
- Table 5.203 *Fan Device Notification Values*
- Table 5.204 *Memory Device Notification Values*
- Table 5.205 *ACPI Device IDs*
- Table 5.206 *Predefined ACPI Names*
- Table 5.207 *Predefined Object Names*
- Table 5.208 *Predefined Operating System Vendor String Prefixes*
- Table 5.209 *Standard ACPI-Defined Feature Group Strings*
- Table 5.210 *DeviceLockInfo Package Values*
- Table 6.1 *Device Identification Objects*
- Table 6.2 *ADR Object Address Encodings*
- Table 6.3 *Additional Language ID Alias Strings*
- Table 6.4 *_PLD Buffer 0 Return Value*
- Table 6.5 *PLD Back Panel Example Settings*
- Table 6.6 *Device Configuration Objects*
- Table 6.7 *HPP Package Contents*
- Table 6.8 *PCI Setting Record Content*
- Table 6.9 *PCI-X Setting Record Content*
- Table 6.10 *PCI Express Setting Record Content*
- Table 6.11 *PCI Express Descriptor Setting Record Content*
- Table 6.12 *PCI Express Register Descriptor*

- Table 6.13 *Platform-Wide _OSC Capabilities DWORD 2*
- Table 6.14 *OSPM USB Support Field*
- Table 6.15 *OSPM USB Control Field*
- Table 6.16 *Mapping Fields*
- Table 6.17 *Example Relative Distances Between Proximity Domains*
- Table 6.18 *Example System Locality Information Table*
- Table 6.19 *Example Relative Distances Between Proximity Domains - 5 Node*
- Table 6.20 *Device Insertion, Removal, and Status Objects*
- Table 6.21 *OST Source Event Codes*
- Table 6.22 *General Processing Status Codes*
- Table 6.23 *Operating System Shutdown Processing (Source Events : 0x100) Status Codes*
- Table 6.24 *Ejection Request / Ejection Processing (Source Events: 0x03 and 0x103) Status Codes*
- Table 6.25 *Insertion Processing (Source Event: 0x200) Status Codes*
- Table 6.26 *Small Resource Data Type Tag Bit Definitions*
- Table 6.27 *Small Resource Items*
- Table 6.28 *IRQ Descriptor Definition*
- Table 6.29 *DMA Descriptor Definition*
- Table 6.30 *Start Dependent Functions Descriptor Definition*
- Table 6.31 *Start Dependent Function Priority Byte Definition*
- Table 6.32 *End Dependent Functions Descriptor Definition*
- Table 6.33 *I/O Port Descriptor Definition*
- Table 6.34 *Fixed-Location I/O Port Descriptor Definition*
- Table 6.35 *Fixed DMA Resource Descriptor*
- Table 6.36 *Vendor-Defined Resource Descriptor Definition*
- Table 6.37 *End Tag Definition*
- Table 6.38 *Large Resource Data Type Tag Bit Definitions*
- Table 6.39 *Large Resource Items*
- Table 6.40 *24-bit Memory Range Descriptor Definition*
- Table 6.41 *Large Vendor-Defined Resource Descriptor Definition*
- Table 6.42 *32-Bit Memory Range Descriptor Definition*
- Table 6.43 *32-bit Fixed-Location Memory Range Descriptor Definition*
- Table 6.44 *Valid Combination of Address Space Descriptor Fields*
- Table 6.45 *WORD Address Space Descriptor Definition*
- Table 6.46 *DWORD Address Space Descriptor Definition*
- Table 6.47 *WORD Address Space Descriptor Definition*
- Table 6.48 *Extended Address Space Descriptor Definition*

- *Table 6.49 Memory Resource Flag (Resource Type = 0) Definitions*
- *Table 6.50 I/O Resource Flag (Resource Type = 1) Definitions*
- *Table 6.51 Bus Number Range Resource Flag (Resource Type = 2) Definitions*
- *Table 6.52 Extended Interrupt Descriptor Definition*
- *Table 6.53 Generic Register Descriptor Definition*
- *Table 6.54 GPIO Connection Descriptor Definition*
- *Table 6.55 GenericSerialBus Connection Descriptors*
- *Table 6.56 I2C Serial Bus Connection Descriptor*
- *Table 6.57 SPI Serial Bus Connection Descriptor*
- *Table 6.58 UART Serial Bus Connection Descriptor*
- *Table 6.59 CSI-2 Connection Resource Descriptor*
- *Table 6.60 Pin Function Description Definition*
- *Table 6.61 Pin Configuration Descriptor Definition*
- *Table 6.62 Pin Group Descriptor Definition*
- *Table 6.63 Pin Group Function Descriptor Definition*
- *Table 6.64 Pin Group Configuration Descriptor Description*
- *Table 6.66 Other Objects and Methods*
- *Table 6.67 OSPM _INI Object Actions*
- *Table 6.68 NVDIMM Label Methods*
- *Table 6.69 _LSI Return Package Values*
- *Table 6.70 _LSR Return Package Values*
- *Table 6.71, _CBR Return Package Values*
- *Table 7.1 Power Resource Object Provisions for Information and Control*
- *Table 7.2 Power Resource Methods*
- *Table 7.3 Device Power Management Child Objects*
- *Table 7.4 PSC Device State Codes*
- *Table 7.5 Power Resource Requirements Package*
- *Table 7.6 S1 Action / Result Table*
- *Table 7.7 S2 Action / Result Table*
- *Table 7.8 S3 Action / Result Table*
- *Table 7.9 S4 Action / Result Table*
- *Table 7.10 BIOS-Supplied Control Methods for System-Level Functions*
- *Table 7.11 System State Package*
- *Table 8.1 C-state/T-state/P-state Coordination Types*
- *Table 8.2 Cstate Package Values*
- *Table 8.3 C-State Dependency Package Values*

- Table 8.4 *Processor Container Device Objects*
- Table 8.5 *Valid Local State Combinations in preceding example system*
- Table 8.6 *OS Initiated Flow*
- Table 8.7 *Example of incorrect platform state in OS Initiated Request without Dependency Check*
- Table 8.8 *OS Initiated Request Semantics with Dependency Check*
- Table 8.9 *Example of incorrect platform state in OS Initiated Request without Hierarchy Parameter*
- Table 8.10 *OS Initiated Request Semantics with Hierarchy Parameter*
- Table 8.11 *Local Power States for the Parent Processor or Processor Container*
- Table 8.12 *Extended LPI Fields*
- Table 8.13 *Flags for LPI states*
- Table 8.14 *Enabled Parent State values for example system*
- Table 8.15 *Entry method example*
- Table 8.16 *_RDI package return values*
- Table 8.17 *_PTC Package Values*
- Table 8.18 *TState Package Values*
- Table 8.19 *T-State Dependency Package Values*
- Table 8.20 *_PCT Package Values*
- Table 8.21 *PState Package Values*
- Table 8.22 *P-State Dependency Package Values*
- Table 8.23 *Continuous Performance Control Package Values*
- Table 8.24 *Performance Limited Register Status Bits*
- Table 8.25 *PCC Command Codes Used by Collaborative Processor Performance Control*
- Table 8.26 *Processor Aggregator Device Objects*
- Table 9.1 *System Indicator Control Methods*
- Table 9.2 *Control Method Ambient Light Sensor Device*
- Table 9.3 *Control Method Lid Device*
- Table 9.4 *ATA Specific Objects*
- Table 9.5 *GTM Method Result Codes*
- Table 9.6 *Tape Presence*
- Table 9.7 *ACPI Floppy Drive Information*
- Table 9.8 *MBM Package Details*
- Table 9.9 *MSM Result Encoding*
- Table 9.10 *Memory Device _OSC Capabilities DWORD number 2*
- Table 9.11 *UPC Return Package Values*
- Table 9.12 *User Presence Detection Device*
- Table 9.13 *Time and Alarm Device*

- Table 9.14 *Generic Buttons Device Child Objects*
- Table 9.15 *Usage Types and Interrupt Polarity*
- Table 9.16 *Common HID Button Usages*
- Table 9.17 *NVDIMM Root Device Function Index*
- Table 9.18 *Status and Extended Status Field Generic Interpretations*
- Table 9.19 *Query ARS Capabilities - Input Buffer*
- Table 9.20 *Query ARS Capabilities - Output Buffer*
- Table 9.21 *Start ARS - Input Buffer*
- Table 9.22 *Start ARS - Output Buffer*
- Table 9.23 *Query ARS Status - Output Buffer*
- Table 9.24 *ARS Data*
- Table 9.25 *ARS Error Record Format*
- Table 9.26 *Clear Uncorrectable Error - Input Buffer*
- Table 9.27 *Clear Uncorrectable Error - Output Buffer*
- Table 9.28 *Translate SPA - Input Payload Format*
- Table 9.29 *Translate SPA - Output Payload Format*
- Table 9.30 *Translate SPA - Translated NVDIMM Device List Output Payload Format*
- Table 9.31 *ARS Error Inject - Input Format*
- Table 9.32 *ARS Error Inject - Output Format*
- Table 9.33 *ARS Error Inject Clear - Input Format*
- Table 9.34 *ARS Error Inject Clear - Output Format*
- Table 9.35 *ARS Error Inject Status Query - Output Format*
- Table 9.36 *ARS Error Inject Status Query - Error Record Format*
- Table 9.37 *ARS Error Inject Options Support*
- Table 9.38 *NVDIMM Device Method Return Status Code*
- Table 9.39 *NCH Return Value*
- Table 9.40 *_NBS Return Value*
- Table 9.41 *_NIC Output Buffer*
- Table 9.42 *_NIH Input Buffer*
- Table 9.43 *_NIH Output Buffer*
- Table 9.44 *_NIG Output Buffer*
- Table 10.1 *Example SMBus Device Slave Addresses*
- Table 10.2 *Smart Battery Objects*
- Table 10.3 *Battery Control Methods*
- Table 10.4 *BIF Return Package Values*
- Table 10.5 *BIX Return Package Values*

- Table 10.6 *BMD Return Package Values*
- Table 10.7 *_BPC Return Package Values*
- Table 10.8 *Battery Power Threshold Support Capability*
- Table 10.9 *_BPS Return Package Values*
- Table 10.10 *BST Return Package Values*
- Table 10.11 *Control Method Battery _OSC Capabilities DWORD2 Bit Definitions*
- Table 10.12 *Power Source Objects*
- Table 10.13 *PIF Method Result Codes*
- Table 10.14 *Power Meter Objects*
- Table 10.15 *PMC Method Result Codes*
- Table 10.16 *Wireless Power Calibration*
- Table 10.17 *Wireless Power Control Notification Values*
- Table 11.1 *Fan Specific Objects*
- Table 11.2 *FIF Package Details*
- Table 11.3 *FPS FanPstate Package Details*
- Table 11.4 *FST Package Details*
- Table 11.5 *Thermal Objects*
- Table 11.6 *Thermal Relationship Package Values 1*
- Table 11.7 *Thermal Relationship Package Values 2*
- Table 12.1 *Read Only Register Table*
- Table 12.3 *Embedded Controller Commands*
- Table 12.4 *Events for Which Embedded Controller Must Generate SCIs*
- Table 12.5 *Read Command (3 Bytes)*
- Table 12.6 *Write Command (3 Bytes)*
- Table 12.7 *Query Command (2 Bytes)*
- Table 12.8 *Burst Enable Command (2 Bytes)*
- Table 12.9 *Burst Disable Command (1 Byte)*
- Table 12.10 *Status Register, SMB_STS*
- Table 12.11 *SMBus Status Codes*
- Table 12.12 *Protocol Register, SMB_PRTCL*
- Table 12.13 *Address Register, SMB_ADDR*
- Table 12.14 *Command Register, SMB_CMD*
- Table 12.15 *Data Register Array, SMB_DATA[i], i=0-31*
- Table 12.16 *Block Count Register, SMB_BCNT*
- Table 12.17 *Alarm Address Register, SMB_ALRM_ADDR*
- Table 12.18 *Alarm Data Registers, SMB_ALRM_DATA[0], SMB_ALRM_DATA[1]*

- Table 12.19 *SMB EC Interface*
- Table 12.20 *Embedded Controller Device Object Control Methods*
- Table 12.21 *EC SMBus HC Device Objects*
- Table 13.1 *SMBus Protocol Types*
- Table 14.1 *Platform Communications Channel Table (PCCT)*
- Table 14.2 *Platform Communications Channel Global Flags*
- Table 14.3 *Generic PCC Subspace Structure*
- Table 14.4 *PCC Subspace Structure type 0 (Generic Communications Subspace)*
- Table 14.5 *PCC Subspace Structure type 1 (HW-Reduced Communications Subspace)*
- Table 14.6 *PCC Subspace Structure type 2 (HW-Reduced Communications Subspace)*
- Table 14.7 *PCC Subspace Structure type 3 and type 4*
- Table 14.8 *HW Registers based Communications Subspace Structure (Type 5)*
- Table 14.9 *Generic Communications Channel Shared Memory Region*
- Table 14.10 *Generic Communications Channel Command Field*
- Table 14.11 *Generic Communications Channel Status Field*
- Table 14.12 *Initiator Responder Communications Channel Shared Memory Region*
- Table 14.13 *Initiator Responder Communications Channel Flags*
- Table 14.14 *Reduced PCC Subspace Shared Memory Region*
- Table 15.1 *Address Range Types*
- Table 15.2 *Input to the INT 15h E820h Call*
- Table 15.3 *Output from the INT 15h E820h Call*
- Table 15.4 *Address Range Descriptor Structure*
- Table 15.5 *Extended Attributes for Address Range Descriptor Structure*
- Table 15.6 *UEFI Memory Types and mapping to ACPI address range types*
- Table 15.7 *Sample Memory Map*
- Table 18.1 *Boot Error Record Table (BERT)*
- Table 18.2 *Hardware Error Source Table (HEST)*
- Table 18.3 *IA-32 Architecture Machine Check Exception Structure*
- Table 18.4 *IA-32 Architecture Machine Check Error Bank Structure*
- Table 18.5 *IA-32 Architecture Corrected Machine Check Structure*
- Table 18.6 *IA-32 Architecture NMI Error Structure*
- Table 18.7 *PCI Express Root Port AER Structure*
- Table 18.8 *PCI Express Device AER Structure*
- Table 18.9 *PCI Express/PCI-X Bridge AER Structure*
- Table 18.10 *Generic Hardware Error Source Structure*
- Table 18.11 *Generic Error Status Block*

- Table 18.12 *Generic Error Data Entry*
- Table 18.13 *Generic Hardware Error Source version 2 (GHESv2) Structure*
- Table 18.14 *Hardware Error Notification Structure*
- Table 18.15 *IA-32 Architecture Deferred Machine Check Structure*
- Table 18.17 *Error Record Serialization Table (ERST)*
- Table 18.18 *Error Record Serialization Actions*
- Table 18.19 *Command Status Definition*
- Table 18.20 *Serialization Instruction Entry*
- Table 18.21 *Serialization Instructions*
- Table 18.22 *Instruction Flags*
- Table 18.23 *Error Record Serialization Info*
- Table 18.24 *Error Injection Table (EINJ)*
- Table 18.25 *Error Injection Actions*
- Table 18.26 *Injection Instruction Entry*
- Table 18.27 *Instruction Flags*
- Table 18.28 *Injection Instructions*
- Table 18.29 *Command Status Definition*
- Table 18.30 *Error Type Definition*
- Table 18.31 *SET_ERROR_TYPE_WITH_ADDRESS Data Structure*
- Table 18.32 *Vendor Error Type Extension Structure*
- Table 18.36 *Trigger Error Action*
- Table 19.1 *ASL Grammar Notation*
- Table 19.2 *Named Object Reference Encodings*
- Table 19.3 *Definition Block Name Modifier Encodings*
- Table 19.4 *ASL Escape Sequences*
- Table 19.5 *Summary of ASL Data Types*
- Table 19.6 *Data Types and Type Conversions*
- Table 19.7 *Object Conversion Rules*
- Table 19.8 *Object Storing and Copying Rules*
- Table 19.9 *Reading from ArgX Objects*
- Table 19.10 *Writing to ArgX Objects*
- Table 19.11 *Reading from LocalX Objects*
- Table 19.12 *Writing to LocalX Objects*
- Table 19.13 *Reading from Named Objects*
- Table 19.14 *Writing to Named Objects*
- Table 19.15 *ASL Operators Summary List*

- Table 19.16 *ASL compiler controls*
- Table 19.17 *ACPI table management*
- Table 19.18 *Miscellaneous named object creation*
- Table 19.19 *Operation Regions and Fields*
- Table 19.20 *Buffer Fields*
- Table 19.21 *Synchronization*
- Table 19.22 *Object references*
- Table 19.23 *Integer arithmetic*
- Table 19.24 *Logical operators*
- Table 19.25 *Method execution control*
- Table 19.26 *Data type conversion and manipulation*
- Table 19.27 *Resource Descriptor macros*
- Table 19.28 *Constants*
- Table 19.29 *Control method objects*
- Table 19.30 *Concatenate Data Types*
- Table 19.31 *Concatenate Object Types*
- Table 19.32 *Debug Object Display Formats*
- Table 19.33 *Field Unit List Entries*
- Table 19.34 *OperationRegion Address Spaces and Access Types*
- Table 19.35 *Match Term Operator Meanings*
- Table 19.36 *Values Returned By the ObjectType Operator*
- Table 19.37 *Pin Configuration Types and Values*
- Table 19.38 *Pin Group Configuration Types and Values*
- Table 19.39 *PLD Keywords and Assignment Types*
- Table 19.40 *PLD Keywords and assignable String Values*
- Table 19.41 *UUID Buffer Format*
- Table 19.42 *UART Serial Bus Connection Resource Descriptor - Version 2 Macro*
- Table 20.1 *AML Grammar Notation Conventions*
- Table 20.2 *AML Byte Stream Byte Values*
- *Table A-1: Default Power State Definitions*
- *Table A-2: Default Power Management Policy*
- *Table A-3: Audio Device Power State Definitions*
- *Table A-4: Audio Device Power Management Policy*
- *Table A-5: COM Port Device Power State Definitions*
- *Table A-6: COM Port Device Power Management Policy*
- *Table A-7: CRT Monitors Power State Definitions*

- *Table A-8: Internal Flat Panel Displays Power State Definitions*
- *Table A-9: External Digital Displays Power State Definitions*
- *Table A-10: Standard TV Devices and Analog HDTVs Power State Definitions*
- *Table A-11: Other (new) Full Screen Display Devices Power State Definitions*
- *Table A-12: Video Controllers (Graphics Adapters) Power State Definitions*
- *Table A-13: Display Device Power Management Policy*
- *Table A-14: Input Device Power State Definitions*
- *Table A-15: Input Device Power Management Policy*
- *Table A-16: Modem Device Power State Definitions*
- *Table A-17: Modem Device Power Management Policy*
- *Table A-18: Network Device Power State Definitions*
- *Table A-19: Network Device Power Management Policy*
- *Table A-20: PC Card Controller Power State Definitions*
- *Table A-21: PC Card Controller Power Management Policy*
- *Table A-22: Hard Disk, CD-ROM and IDE/ATAPI Removable Storage Devices Power State Definitions*
- *Table A-23: Floppy Disk Devices Power State Definitions*
- *Table A-24: IDE Channel Devices Power State Definitions*
- *Table A-25: Hard Disk, Floppy Disk, CD-ROM and IDE/ATAPI Removable Storage Devices Power Management Policy*
- *Table A-26: IDE Channel Devices Power Management Policy*
- *Table B-1: Video Extension Object Requirements*
- *Table B-2: Video Output Device Attributes*
- *Table B-3: Example Device IDs*
- *Table B-4: Notifications for Display Devices*
- *Table B-5: Output Device Status*
- *Table B-6: Device State for _DGS*
- *Table B-7: Device State for _DSS*
- *Table B-8: Notification Values for Output Devices*

List of Figures

- *Fig. i-1 - ACPI overview*
- *Fig. i-2 - ACPI Structure*
- *Fig. i-3 - ASL and AML*
- *Fig. i-4 ACPI Initialization*
- *Fig. i-5 Runtime Thermal Event*
- *Fig. 1.1 OSPM/ACPI Global System*
- *Fig. 3.1 Global System Power States and Transitions*
- *Fig. 3.2 Example Modem and COM Port Hardware*
- *Fig. 3.3 Reporting Battery Capacity*
- *Fig. 3.4 Formula for Remaining Battery Percentage*
- *Fig. 3.5 Formula for the Present Drain Rate*
- *Fig. 3.6 Low Battery and Warning*
- *Fig. 4.1 Generic Hardware Feature Model*
- *Fig. 4.2 Global States and Their Transitions*
- *Fig. 4.3 Example Event Structure for a Legacy/ACPI Compatible Event Model*
- *Fig. 4.4 Block Diagram of a Status/Enable Cell*
- *Fig. 4.5 Example Fixed Hardware Feature Register Grouping*
- *Fig. 4.6 Register Blocks versus Register Groupings*
- *Fig. 4.7 Power Management Timer*
- *Fig. 4.8 Fixed Power Button Logic*
- *Fig. 4.9 Fixed Hardware Sleep Button Logic*
- *Fig. 4.10 Sleeping/Wake Logic*
- *Fig. 4.11 RTC Alarm*
- *Fig. 4.12 Power Management Events to SMI/SCI Control Logic*
- *Fig. 4.13 Example of General-Purpose vs. Generic Hardware Events*
- *Fig. 4.14 Example Generic Address Space Lid Switch Logic*
- *Fig. 5.1 Root System Description Pointer and Table*
- *Fig. 5.2 Description Table Structures*
- *Fig. 5.3 APIC-Global System Interrupts*
- *Fig. 5.4 8259 - Global System Interrupts*
- *Fig. 5.5 MPST ACPI Table Overview*
- *Fig. 5.6 Memory Power State Transitions*
- *Fig. 5.7 Image Offset*
- *Fig. 5.8 FPDT Hierarchy Structure*
- *Fig. 5.9 NVDIMM Firmware Interface Table (NFIT) Overview*

- Fig. 5.10 *HMAT Representation*
- Fig. 5.11 *Memory Side Cache Example*
- Fig. 5.12, *Mapping a PDTT Debug Trigger Table Entry to a PCCT PCC Subspace*
- Fig. 5.13 *Example: Platform with four debug triggers*
- Fig. 5.14 *L1 Cache Structure*
- Fig. 5.15 *Cache Type Structure - Type 1 Example*
- Fig. 5.16 *Example ACPI NameSpace*
- Fig. 5.17 *AML Encoding*
- Fig. 6.1 *System Panel and Panel Origin Positions*
- Fig. 6.2 *Laptop Panel and Panel Origin Positions*
- Fig. 6.3 *Default Shape Definitions*
- Fig. 6.4 *PLD Back Panel Rendering*
- Fig. 6.5 *System Locality information Table*
- Fig. 6.6 *Device Ejection Flow Example Using _OST*
- Fig. 7.1 *Working / Sleeping State object evaluation flow*
- Fig. 8.1 *Processor Power States*
- Fig. 8.2 *Throttling Example*
- Fig. 8.3 *Equation 1 Duty Cycle Equation*
- Fig. 8.4 *Example Control for the STPCLK*
- Fig. 8.5 *ACPI Clock Logic (One per Processor)*
- Fig. 8.6 *Processor Hierarchy*
- Fig. 8.7 *Power states for processor hierarchy*
- Fig. 8.8 *Worst case wake latency*
- Fig. 8.9 *Energy of states A,B and C versus sleep duration*
- Fig. 8.10 *Platform performance thresholds*
- Fig. 8.11 *OSPM performance controls*
- Fig. 9.1 *A five-point ALS Response Curve*
- Fig. 9.2 *A two-point ALS Response Curve*
- Fig. 9.3 *Example Response Curve for a Transflective Display*
- Fig. 9.4 *USB ports*
- Fig. 9.5 *Persistence of expired timer events*
- Fig. 9.6 *System transitions with WakeAlarm — Timer*
- Fig. 9.7 *System transitions with WakeAlarm — Policy*
- Fig. 9.8 *Vendor/Device Specific Driver Loading*
- Fig. 10.1 *Typical Smart Battery Subsystem (SBS)*
- Fig. 10.2 *Single Smart Battery Subsystem*

- Fig. 10.3 *Smart Battery Subsystem*
- Fig. 10.4 *Remaining Battery Percent Formula*
- Fig. 10.5 *Remaining Battery Life Formula*
- Fig. 10.6 *Power Meter and Power Source/Docking Namespace Example*
- Fig. 11.1 *ACPI Thermal Zone*
- Fig. 11.2 *Thermal Events*
- Fig. 11.3 *Temperature and CPU Performance Versus Time*
- Fig. 11.4 *Active and Passive Threshold Values*
- Fig. 11.5 *Cooling Preferences*
- Fig. 12.1 *Shared Interface*
- Fig. 12.2 *Private Interface*
- Fig. 12.3 *Interrupt Model*
- Fig. 13.1 *Bit Encoding Example*
- Fig. 13.2 *Smart Battery Subsystem Devices*
- Fig. 13.3 *Smart Battery Device Virtual Registers*
- Fig. 14.1 *Communication flow of the doorbell protocol*
- Fig. 14.2 *Communication flow for notifications on Responder subspaces*
- Fig. 16.1 *Example Sleeping States*
- Fig. 16.2 *Platform Firmware Initialization*
- Fig. 16.3 *Example Physical Memory Map*
- Fig. 16.4 *Memory as Configured after Boot*
- Fig. 16.5 *OS Initialization*
- Fig. 18.1 *APEI error flow example with external RAS controller*
- Fig. B-1 *Example Display Architecture*

Revision History

Many people have contributed to the contents of this specification, including the following:

- ACPI Specification Working Group (ASWG)
- Tianocore Community Members
- Others as noted in the Revision History below

Table 1: Changes in this release

ACPI Rev #	Issue / Description / Submitter	Affected Content
6.5	2122 DTPR signature reservation	Table 5.5
6.5	2151 Reserve an _SB._OSC bit and an OperationRegion Subtype for Platform Runtime Mechanism (PRM)	Table 5.182, Table 6.13
6.5	2152 Code first: Add the Virtual I/O Translation (VIOT) Table (Al Stone and others)	Section 5.2.32
6.5	2162 Reserve ACPI table signature for SVKL	Table 5.6
6.5	2177 Reserve ACPI table signature for CCEL	Table 5.6
6.5	2188 Code First: Add ‘CXL Root Object’ _HID (Vishal Verma)	Section 5.2.6, Table 5.205
6.5	2195 Remove section 9.7 Embedded Controller Device	<i>Appendix C: Deprecated Content</i>
6.5	2196 Introduce unaccepted memory type - Address-RangeUnaccepted	Table 15.1
6.5	2198 Clarification to Address Space ID	Table 5.1
6.5	2203 Code First: Add APIC Structures for Loongarch in MADT (LV Jianmin)	Section 5.2.12, Section 5.2.12.20 & sections following.
6.5	2206 Add new PERSISTENT_CPU_CACHES bits to FADT Fixed Feature Flags table	Table 5.10
6.5	2210 Update reference link for the PnP BIOS Spec	Section 6.2.2
6.5	2215 Update to S4 language	Table 5.13, Section 16.1.4.1
6.5	2224 Code First - _DSC Deepest State for Configuration (Rafael Wysocki)	Table 7.3, Section 7.3.27
6.5	2228 Code First - RASF Gen2 (Samer El-Haj-Mahmoud)	Section 5.2, Table 5.5, Section 5.2.21
6.5	2233 Connection Sharing update for Serial Bus Connection Descriptor	Section 6.4.3.8.2.1, Table 6.55, Section 19.6.58
6.5	2236 Code First: Generic Port, performance data for hotplug memory (Dan Williams)	Section 5.2.16, Section 5.2.16.6, Table 5.68, Section 5.2.16.7
6.5	2239 Code First - RAS2 Error Record Local Address to System Physical Address Conversion (Samer El-Haj-Mahmoud)	Table 5.86, Section 5.2.21.2.2
6.5	2241 Reserve ACPI Device ID for Audio Composition Device	Table 5.205
6.5	2245 Code First - DSD property for uefi-clock-frequency (Samer El-Haj-Mahmoud)	Table 6.39, Section 6.4.3.14, Section 19.6.154
6.5	2248 Adding WDDT name reservation into spec	Table 5.6
6.5	2250 Reserve APMT table name	Table 5.6
6.5	2253 Clarification - Time and Alarm Device methods requirements (Samer El-Haj-Mahmoud)	Section 9.17.2, Section 9.17.5, Section 9.17.6, Section 9.17.7, Section 9.17.8, Section 9.17.9, Section 9.17.10

continues on next page

Table 1 – continued from previous page

6.5	2258 Deprecate CDIT/CRAT	<i>Appendix C: Deprecated Content</i>
6.5	2261 Reserve KEYP table name	Table 5.5
6.5	2267 Code first - EINJ updates for CXL (Thanunathan Rangarajan)	Table 18.30
6.5	2268 Updated ECR for adding APIC structures for Loongarch in MADT	Section 5.2.12, Section 5.2.12.20 & sections following.
6.5	2272 Code First - Allow FFH OpRegion (Samer El-Haj-Mahmoud)	Table 5.182, Section 5.5.2.4.2, Table 6.13
6.5	2275 MHSP table signature reservation	Table 5.5
6.5	2281 Reserve “AGDI” table signature	Table 5.5
6.5	2285 Code First - MADT GICC new flags (Samer El-Haj-Mahmoud)	Table 5.37
6.5	2287 Code First - EINJv2 (Harb Abdulhamid and others)	Table 18.25, Section 18.6.2, Section 18.6.7
6.5	2293 _ADR and _UPC changes, _PDO addition for USB4 and USB-C	Section 1.10, Table 6.14, Table 9.11, Section 9.12.1, Section 9.12.2
6.5	2294 Reset Reason Health Record	Section 5.2.31.5
6.5	2296 Reserve “NBFT” table signature	Table 5.5
6.5	2297 Miscellaneous GUIDed Table Entries definition	Section 5.2.4, Table 5.5, Section 5.2.33
6.5	2298 Reserve “SWFT” table signature	Table 5.5
6.5	2303 Code First - Armv9 TRBE Support (Thanunathan Rangarajan)	Table 5.36
6.5	2309 Update of FADT Minor Version	Table 5.9
6.5	2312 Update to the HEST table and adding new error source descriptor	Table 18.2
6.5	2314 Code First - Add confidential computing extension for ACPI (Jiewen Yao)	Section 5.2.34, Section 5.2.35
6.5	2316 Add an “attribution” link to the ACPI spec	See top of this Revision History list.
6.5	2322 File name references consistency (upper/lower case)	throughout the spec
6.5	2328 Add ACPI Burst Mode Opt-Out	Table 12.20
6.5	2331 IAPC_BOOT_ARCH’s description in FADT table points to an incorrect table	Table 5.9
6.5	2332 EISAID macro corrections	Section 6.5.11, Section 19.6.64
6.5	2333 USB power data object (_PDO)	Section 9.13
6.5	2334 Power Button Override clarification	Table 4.1
6.5	2335 Comments on review draft	Section 5.2.31.5, Table 5.168
6.5	2338 Table name reservation (IERS)	Table 5.6
6.5	2345 draft spec feedback	Section 5.2.16.6, Table 5.68, and miscellaneous corrections
6.5	2346 Inclusive language update for ACPI spec	Section 1.1.1

Table 2: Changes in previous releases

ACPI Rev #	Issue # / Description	Affected Content
6.4 A	2179 _BPT control method: arg2’s description is incomplete in ACPI 6.4 draft	Section 10.2.2.10

continues on next page

Table 2 – continued from previous page

6.4 A	2181 Missing new ACPI 6.4 predefined names in Table 5.173: Predefined ACPI Names	Table 5.206
6.4 A	2187 Some parts of FPDT and SDEV sections should be re-ordered	Section 5.2.27.1
6.4 A	2193 Remove section 9.4	<i>Appendix C: Deprecated Content</i>
6.4 A	2194 Remove deprecated content in section 8.4	<i>Appendix C: Deprecated Content</i>
6.4 A	2195 Remove section 9.7	<i>Appendix C: Deprecated Content</i>
6.4 A	2198 Clarification to Address Space ID	Table 5.1
6.4 A	2211 Two corrections to the Buffer 0 Return Value table	Table 6.4
6.4 A	2216 Incorrect DBPG2 reference	Table 5.6
6.4 A	2219 PPTT is missing in DESCRIPTION_HEADER Signatures for tables defined by ACPI	Table 5.5
6.4 A	2220 Document meaning behind _MEM attributes	Section 6.4.3.5.4.1
6.4 A	2221 Document architecture mapping for extended attributes in Type Specific Attributes	Section 6.4.3.5.4.1
6.4 A	2223 Code First - correct _DMA resource type example	Section 6.2.4
6.4 A	2242 Note misplaced in the Memory Resource Flag Definitions table (resource type=0)	Table 6.49, plus other sections of chapter 6.
6.4 A	2244 shareable (10 used) or sharable (3 used) in ACPI spec 6.4	Table 5.9, Table 5.206, Section 9.12
6.4 A	2254 Incorrect link in 6.4.3.7 Generic Register Descriptor	Section 6.4.3.7
6.4 A	2257 What is meant by handling an error.	Table 18.3
6.4 A	2273 _STA and _DIS Clarifications	Section 6.2.3, Section 6.3.7
6.4 A	2274 Code First - Update HW Error Notification Structure to reference SDEI	Table 18.14
6.4 A	2276 Pin Group Configuration Descriptor: Resource Identifier binary encoding incorrect	Table 6.64
6.4 A	2282 Code first - Fix incorrect reference to “Memory Aggregator Device”	Table 6.64
6.4 A	2283 Code first - BGRT table “valid” field typo	Table 5.105
6.4 A	2284 Inclusive language rename for PCCT sub-space types 3 & 4	Table 14.7, Table 14.12, Table 14.13, Section 14.5, Section 14.6.1, Section 14.6.2
6.4 A	2299 Correction for Device Power Management Objects	Section 7.3
6.4 A	2301 Invalid section reference in CopyObject ASL operator definition	Section 19.6.17
6.4 A	2304 _PLD content missing in table 6.4, spec rev 6.4	Table 6.4
6.4 A	2305 Remove orphaned reference to deprecated PPTT Type 0	Section 5.2.30.1
6.4 A	2307 Missing note numbers in Appendix B table B3	<i>Appendix B: Video Extensions</i>
6.4 A	2308 Update/Clarification to _STA	Section 6.3.7
6.4 A	2310 FADT Format clarifications	Table 5.9
6.4 A	2323 Update of FADT Minor Version for ACPI 6.4 Errata A	Table 5.9
6.4	1933 Remove obsolete DDBHandle data type	Section 19, Section 20
6.4	1975 NFIT PMTT Memory Topology	Section 5.2.22.12, Section 9.19.3
6.4	1988 VDIMM SPA Location Cookie	Table 5.128
6.4	1991 Generic Initiator clarifications	Table 5.68, Section 5.2.28.1, and Section 5.2.28.4

continues on next page

Table 2 – continued from previous page

6.4	1997 Add Fuel Gauge Support to Control Method Battery device	Section 10.2, Section 10.2.1, Table 10.3, Table 10.11
6.4	2006 Add _SB_OSC bit for native USB 4 support/control	Section 6.2.11.1.3, Table 6.13, Section 6.2.11.3
6.4	2010 Define new PCC Structure (Type 5)	Section 14.1.7, Section 14.4, Section 5.2.29.1
6.4	2044 Query ARS Capabilities Clarification	Table 9.20
6.4	2045 CXL ACPI enumeration	Table 5.205, Section 6.5.11
6.4	2056 Signature Reservation for Regulatory Graphics Resource Table (RGRT)	Table 5.6
6.4	2070 Define Address encoding for PCI BAR Target GAS structure	Table 5.2, Table 6.13
6.4	2075 Add reference to CDAT Structure from ACPI table	Section 17, https://uefi.org/acpi
6.4	2076 Reserve CEDT signature	Table 5.6, https://uefi.org/acpi
6.4	2077 Clarify CXL _CBR enumeration method	Table 6.71
6.4	2081 Add Connection Descriptor definition and macro for MIPI CSI-2	Table 6.55, Section 6.4.3.8.2.4, Section 19.6.24
6.4	2087 Add MultiProcessor Wakeup structure	Table 5.21, Section 5.2.12.19
6.4	2090 ECR for Battery Charge Limiting (BCL) mode support	Section 3.9.6, Table 6.13, Table 10.10, Table 10.6, Section 10.2.2.5
6.4	2094 New platform telemetry data table - PTDT, reservation and definition	Table 5.5, Section 5.2.31
6.4	2104 Reserve ACPI table signature for the PRMT	Table 5.6
6.4	2105 Increase FADT Major & Minor number to match next ACPI release.	Table 5.9
6.4	2108 Add new ACPI device ID for USB4 host routers	Table 5.205
6.4	2111 Add Access Components for Secure ACPI Enumerated Devices in the SDEV table	Section 5.2.27.1.1
6.4	2118 AEST table signature reservation	Table 5.6
6.4	2120 MPAM Table Name Reservation	Table 5.6
6.4	2121 HMAT updates to support systems with heterogeneous memory	Section 5.2.28.1, Section 5.2.28.4
6.4	2126 Rename SBSA Generic Watchdog and move the spec link to the UEFI website	Section 5.2.25, Table 5.119, and Section 5.2.25.2
6.4	2127 BDAT name reservation	Table 5.6
6.4	2133 Remove reference to DMA Protection Policy Table (DPPT)	Table 5.5
6.4	2137 Extend _DDC to support greater than 256 byte buffer return	<i>_DDC (Return the EDID for this Device)</i>
6.4	2138 ACPI-based Identifiers for Caches	Table 5.156, Section 5.2.30.1, Table 5.159, Table 5.160
6.4	2144 Clarify SSDT load order	Section 5.2.11
6.4	2146 Error in the HMAT System Locality Latency and Bandwidth Information Structure	Table 5.148
6.4	2150 Clarify description of CoordType in _PSD object	Table 8.1, Table 8.3, Table 8.19, Table 8.22
6.4	2156 Corrections to the FPDT	Fig. 5.8, Table 5.106, Section 5.2.24.1, Section 5.2.24.2, Section 5.2.24.3, Section 5.2.24.4, Section 5.2.24.5, Section 5.2.24.6, Section 5.2.24.7, Section 5.2.24.8

continues on next page

Table 2 – continued from previous page

6.4	2157 Processor object cleanup missed ProcessorObj in ObjectTypeKeyword list	<i>ObjectTypeKeyword</i> , Table 19.36
6.4	2159 6.3A contains incorrect heading levels for some sections	various sections
6.4	2162 Reserve ACPI table signature for the SVKL	Table 5.6
6.4	2169 IRQ macro description incorrectly refers to the IO macro	Section 19.6.66
6.4	2170 Feedback on the 6.4 draft	multiple sections; see Mantis for details
6.4	2171 Heading changes for consistency in section 19.6	Section 19.6.102, Section 19.6.103, Section 19.6.104, Section 19.6.105, and Section 19.6.106
6.4	2176 EINJ: Correction for GET_COMMAND_STATUS Action.	Table 18.18
6.4	2179 _BPT control method: arg2 description is incomplete in ACPI 6.4 draft	Section 10.2.2.10
6.4	2180 New section from ECR M2010 misplaced in ACPI 6.4 draft	Section 14.1.7
6.4	2181 Missing new items in ACPI Predefined Names table	Table 5.206
6.4	2182 Multiprocessor Wakeup Structure misplaced in spec	Table 5.21, Section 5.2.12.19
6.4	2183 Incorrect PHAT reference in Table 5-5	Table 5.5
6.4	2186 Error in sample code	Section 5.6.9.2, Section 5.6.9.3
6.4	2187 Some parts of SDEV sections should be re-ordered	Section 5.2.27.1
6.4	2191 Feedback on ACPI 6.4 draft	<i>various sections</i>
6.4	2197 Typos in the t-state dependency and p-state dependency tables	Table 8.19, Table 8.22
6.3 A	1952 Serious issues with Generic Serial Bus chapters	Section 5.5
6.3 A	1972 Add links to grammar definitions	Section 19.2, Section 20.2, Section 21.2.2
6.3 A	1973 Change name of TypeXOpCodes for clarity	Section 19.2, Section 20.2
6.3 A	1977 Errata for GHES_ASSIST (APEI) feature	Table 18.3, Table 18.5, Table 18.10, Table 18.15, and Section 18.7
6.3 A	1981 Minor issues with BGRT description and field names.	Table 5.105
6.3 A	1985 ASL macro definitions reversed between “For” and “Fprintf”	Section 19.3.4
6.3 A	1990 _PR0 fixes	Section 7.3.8
6.3 A	1995 Clarification to the Guaranteed Performance Register implementation	Section 8.4.6.1.1.6
6.3 A	2001 Clarifications for PCI Express AER ownership	Section 18.3.2.4, Section 18.3.2.5, Section 18.3.2.6
6.3 A	2004 Appendices numbering	<i>Appendix A: Device Class Specifications, Appendix B: Video Extensions, Appendix C: Deprecated Content</i>
6.3 A	2011 _DSD link in Generic Buttons Device Child Objects table	Section 9.18
6.3 A	2012 Clarify allowed values for ACPI0007 _UIDs	Section 5.2.12, Section 6.1.12
6.3 A	2021 Typo in PM_TMR_BLK field	Table 5.9

continues on next page

Table 2 – continued from previous page

6.3 A	2022 Errors in description of “X_GPE0_BLK”	Table 5.9
6.3 A	2037 Incorrect reference in Real Time Clock Alarm	Section 4.8.2.4
6.3 A	2047 Clarifications and Fixes to the Error Injection (EINJ) section	Section 18.6
6.3 A	2052 Clarify behavior of PerformanceLimitedRegister in _CPC	Section 8.4.6.1.3.2
6.3 A	2057 Clarify wording of delivered performance constraints in CPPC	Section 8.4.6.1.3.1
6.3 A	2059 EISAID Macro - missing algorithm	Section 19.3.4
6.3 A	2064 Make “DPA” definition more generic	<i>Device Physical Address (DPA)</i> , Section 9.19.7.8, Section 9.19.7.8.3
6.3 A	2067 Clarify _HID and _ADR usage	Section 6, Section 6.1, Section 6.1.1, Section 6.1.2, Section 6.1.5
6.3 A	2069 Update figure OSPM/ACPI Global System	Fig. 1.1
6.3 A	2072 Deprecate “PPTT Type 2 - Processor ID” section	Was section 5.2.29.3 in ACPI Spec 6.3
6.3 A	2098 Clarification of supported ACPI platform implementations	Table 3.3
6.3 A	2100 Correction/Clarification of _CBA description	Table 5.206
6.3 A	2109 Incorrect SLIT reference in “DESCRIPTION_HEADER Signatures for tables defined by ACPI”	Table 5.5
6.3 A	2112 _TZP questions and issues	Section 11.4.26
6.3 A	2113 Label tables in the OS Initiated section of Idle State Coordination	Section 8.4.3.2.2, Section 8.4.3.2.2.1
6.3 A	2115 Duplicate definition of RawDataBufferTerm	Section 19.2.6
6.3 A	2123 Interrupt Polarity _LL values do not agree between chapters	Section 19.6.64 and Section 19.6.66
6.3 A	2128 Some changes from ECR 1588 are missing in ACPI 6.3	Section 19.6.64
6.3 A	2140 Incorrect offsets in PCC Subspace Structures type 3 and 4	Table 14.7
6.3 A	2141 Typos in Chapters 5 and 17	Revision History, Table 5.23, Section 17.3.1, and Section 17.4.1
6.3 A	2145 Error in the PCC Type 3 and 4 subspace description	Table 14.7
6.3	1851 Extend GTDT to describe ARMv8.1 architected CNTHV timer	Section 5.2.24
6.3	1855 ARS Error Inject	Table 9-299, Section 9.20.7.7, Section 9.20.7.9.1, Section 9.20.7.12
6.3	1867 Add Trigger order to PCC Identifier structure within PDTT	Section 5.2.28
6.3	1873 Peripheral-attached Memory	Table 5-132
6.3	1883 Reserve the table names “CRAT” and “CDIT”	http://uefi.org/acpi
6.3	1893 New NVDIMM Device methods _NCH and _NBS	Section 9.20.8.1, Section 9.20.8.2
6.3	1898 PCC Operation Region	Section 5.5.2.4, Section 6.5.4, Section 19.2.7, Section 19.6, Section 20.2.5.2
6.3	1900 I3C host controller support	Table 6-190, Table 6-241
6.3	1904 Generic Initiator Affinity Structure	Section 5.2.16
6.3	1910 NVDIMM Address Range Scrubbing (ARS) interface update	Section 5.6.6, Section 9.20.7
6.3	1911 _PRD object in Table 6-186 has no definition	Appendix C

continues on next page

Table 2 – continued from previous page

6.3	1913 New NVDIMM Device methods for Health Error Injection	Section 5.6.6, Section 9.20.8
6.3	1914 HMAT Enhancements	Section 5.2.27
6.3	1922 _HPX Enhancements	Section 6.2.9
6.3	1930 ASL: Make some arguments to ASL operators optional	Section 19.6.7, Section 19.6.46, Section 19.6.63, Section 19.6.88
6.3	1931 ASL: extend Load() operator to allow table load from an ASL buffer	Section 19.6.76
6.3	1932 ASL: deprecate Unload operator	Section 19.6.146 and related references
6.3	1934 SPE support for ARM	Section 5.2.12.14, Table 5-155
6.3	1939 Error Disconnect Recover Notification	Table 5-165, Section 6.3.5
6.3	1944 Outdated copied text from PCI Firmware Spec	Section 6.2.11.3, Section 6.2.11.4
6.3	1946 Generic Initiator _OSC Bit	Section 5.2.16.6, Table 6-200
6.3	1948 Adds an “Online Capable” flag to the Local APIC, Local SPAPIC, and x2APIC structures in MADT	Tables 5-46, 5-47, 5-55, and 5-58
6.3	1958 PCC Operation Region Updates	Section 5.5.2.4, Section 19.2.7, Table 19-420, Section 20.2.5.2
6.3	1959 Update to ECR 1914	Table 5-146
6.3	1978 GT Block Timers table - update the Timer Interrupt Mode description	Table 5-126
6.3	1979 ACPI version change from 6.2 to 6.3	Table 5-33
6.3	1980 Fix link to local APIC flags in the Processor Local APIC Structure table	Table 5-46
6.2 B	1819 Errata: remove support for multiple GICD structures	Table 5-43
6.2 B	1852 Fix Inconsistent TranslateType Language	Section 19.6.33, Section 19.6.34, Section 19.6.41, Section 19.6.42, Section 19.6.109, Section 19.6.110, Section 19.6.151
6.2 B	1870 PPTT Clarifications	Section 5.2.29.1
6.2 B	1881 Incorrect reference “Memory Devices” in “5.2.21.10 Interaction with Memory Hot Plug”	Section 5.2.21.10
6.2 B	1882 Incorrect EINJ table references/link	Table 18-404
6.2 B	1894 SRAT GICC Flags Field Definition Errata	Table 5-76
6.2 B	1905 Missing description in 6.1.9 title in ACPI 6.2a	Section 6.1.9
6.2 B	1909 Update NFIT SPA Range Structure	Table 5-132
6.2 B	1929 Miscellaneous Errata	Section 19.6.38, Section 19.6.53, Section 19.6.54, Removed redundant Interrupt section (now Section 19.6.63)
6.2 B	1945 NFIT_SPA_ECR	Section 5.2.25.2
6.2 B	1951 _PXM Clarifications	Section 5.2.16, Section 5.2.16.6, Section 6.2.14, Section 6.2.15, Section 17.2, Section 17.2.1, Section 17.3, Section 17.3.1, Section 17.4, Section 17.4.1
6.2 B	1960 PWR_BUTTON description should say “power button”, not “sleep button”	Table 5-34
6.2 B	1962 Clarifications for the use of _REG methods	Section 6.5.4
6.2 B	1965 Clean up Address Space ID	Table 5-25, Table 6-238, Section 19.6.114, Section 19.2.7

continues on next page

Table 2 – continued from previous page

6.2 B	1968 Clarifications for ACPI Namepaths	Section 5.2
6.2 A	1839 Missing space in title of ACPI RAS Feature Table (RASf)	Section 5.2, Section 5.2.20, Table 5-29
6.2 A	1837 Typos in Extended PCC subspaces (types 3 and 4)	Section 14.1.6
6.2 A	1831 Add a new NFIT Platform Capabilities Structure	Section 5.2.25.1, Figure 5-22, Table 5-131, Section 5.2.25.9
6.2 A	1827 PPTT ID Type Structure offsets	Section 5.2.29.3
6.2 A	1825 Remove bits 2-4 in the Platform RAS Capabilities Bitmap table	Section 5.2.20.4
6.2 A	1820 Region Format Interface Code description	Section 5.2.25.6
6.2 A	1819 Remove support for multiple GICD structures	Section 5.2.12, Section 5.2.12.1
6.2 A	1814 PDTT typos and PPTT reference	Revision History, Section 5.2, Section 5.2.28
6.2 A	1812 Minor correction to Trigger Action Table	Section 18.6.4
6.2 A	1811 General Purpose Event Handling flow	Section 5.6.4
6.2	1795 ACPI Table Signature Reservation	Table 5-30
6.2	1781 Clarify ResourceUsage Descriptor Argument	Table 6-193
6.2	1780 Add DescriptorName to PinFunction and PinConfig Macros	Section 19.6.102 and Section 19.6.103
6.2	1770 Update Revision History	Revision History
6.2	1769 FADT Format: ACPI Version update to reflect 6.2 versus 6.1	Table 5-33
6.2	1755 Deprecate PCC Platform Async Notifications	Section 14.4, and Section 14.5.1
6.2	1743 PinGroupFunctionConfig resource descriptors update	Section 6.4.3.11, Section 6.4.3.12, Section 6.4.3.13
6.2	1738 PCIEXP_WAKE Bits description updates	Table 4-15, Table 4-16, and Table 5-34
6.2	1731 Software Delegated Exception HW error notification	Section 18-394
6.2	1725 NVST Updates - NFIT ARS Error Injection	Section 9.20.7.9, Section 9.20.7.10, and Section 9.20.7.11
6.2	1724 NVST Updates - Platform RAS Capabilities Updates	Section 5.2.20.4
6.2	1723 NVST Updates - Translate SPA DSM Interface	Section 2.1, Section 9.20.7.8
6.2	1722 NVST Updates - ARS Updates	Section 2.1, Section 9.20.7.2, Section 9.20.7.4, Section 9.20.7.5, and Section 9.20.7.6
6.2	1721 NVST Updates - Labels	Section 2.1, Section 5-184, and Section 6.5.10
6.2	1717 ASL Grammar Update for Reference Operators	Section 19.2
6.2	1714 Reserve the table name “SDEI”	Table 5-30
6.2	1705 Add Heterogeneous Memory Attributes Tables (HMAT)	Section 5.2, Section 5.6.6, Section 5.6.8, Section 6.2, Section 6.2.18, and Section 17.4
6.2	1703 Time & Alarm Device _GCP new bits	Section 9.18.2
6.2	1680 Pin Group, Pin Group Function and Pin Group Configuration Descriptors and Macros	Table 6-224 and Section 6.4.3.10
6.2	1679 Pin Configuration Descriptor and Macro	Table 6-224 and Section 6.4.3.10
6.2	1677 CPPC Registers in System Memory	Section 6.2.11.2 and Section 8.4.7.1
6.2	1674 GHES_ASSIST Proposal	Section 18.3.2

continues on next page

Table 2 – continued from previous page

6.2	1669 FADT HEADLESS flag should be valid for HW_REDUCED_ACPI platforms	Section 5.2.9
6.2	1667 Processor Properties Topology Table (PPTT)	Section 5.2.29
6.2	1659 Master Slave PCC channels	Chapter 14, Platform Communications Channel (PCC)
6.2	1656 SRAT Support for ITS	Section 5.2.16
6.2	1650 CPPC Support for Multiple PCC Channels	Table 6-200 and Section 8.4.7.1.9
6.2	1649 ECR: Minor updates to IA-32 Architecture Deferred Machine Check	Section 18.3.2.10
6.2	1645 Add _STR Support for Thermal Zones	Section 6.1, Section 6.1.10, Section 11.4, Section 11.4.14, and Section 11.7.1
6.2	1632 Secure Devices Table (SDEV)	Table 5-30
6.2	1611 Add a _PPL object to processor devices	Section 8.4.7
6.2	1597 ASL For() Conditional Loop Macro	Section 19.6.51, Section 19.2.5, Section 19.2.6, and Section 19.3.4
6.2	1588 Clarification on Interrupt Descriptor Usage for “Interrupt Combining”	Section 6.2.11.2, Section 6.4.3.6, Section 19.6.62
6.2	1585 Reserve table signature “WSMT,” with reference to ACPI links page for more details	Table 5-30
6.2	1583 Diverse Highest Processor Performance	Table 5-158 and Table 6-200
6.2	1578 Function Config Descriptor and Macro	Table 6-213 and Section 6.4.3.9
6.2	1576 Platform Debug Trigger Table (PDTT)	Section 5.2.28
6.2	1573 Extensions to the ASL Concatenate operator	Section 19.2.6 and Section 19.6.12
6.2	1569 Add new introduction (background) section	Background chapter
6.1 Errata A	1796 Clarify that Type 1 can never support Level triggered platform interrupt	Section 14.1.4
6.1 Errata A	1785 Lack of clarity on use of System Vector Base on GICD structures	Section 5.2.12.15
6.1 Errata A	1783 Clarification on Interrupt Descriptor Usage for Bit [0] Consumer/Producer	Table 6-237
6.1 Errata A	1760 Typo - incorrect bit offsets in the PM1 Enable Registers Fixed Hardware Feature Enable Bits table.	Table 4-16
6.1 Errata A	1758 Minor Errata in ERST tables, Serialization Instruction Entry and Injection Instruction Entry.	Table 18-399 and Table 18-405
6.1 Errata A	1756 Errata: Ensure non-secure timers are accessible to non-secure in the Flag Definitions: Common Flags table.	Table 5-126
6.1 Errata A	1740 Errata in section 9.13: wrong reference	Section 9.13
6.1 Errata A	1715 0 is a valid GSIV for the secure EL1 physical timer in GTDT	Table 5-120
6.1 Errata A	1687 Typo in the Reserved field of the GIC ITS Structure table.	Table 5-66
6.1 Errata A	1686 Clarification of the FADT HW_REDUCED_ACPI flag description in the FADT Format table.	Table 5-33
6.1 Errata A	1676 Clarifications for the ASL Buffer (Declare Buffer Object)	Section 19.6.10
6.1 Errata A	1671 Typo in Memory Affinity Structure table	Section 5-72
6.1 Errata A	1670 Update for _OSI return value	Section 5.7.2
6.1 Errata A	1664 Clarification of the RSDP Structure table, Revision description.	Table 5-66

continues on next page

Table 2 – continued from previous page

6.1 Errata A	1662 Clarification of the Generic Communications Channel Command Field table.	Table 14-370
6.1 Errata A	1661 typos in the Generic Communications Channel Status Field table and the Platform Notification section.	Table 14-371 and Section 14.5
6.1 Errata A	1660 type in the Generic Communications Channel Shared Memory Region table	Table 14-369
6.1 Errata A	1651 LPI Clarifications	Section 8.4.4.3
6.1 Errata A	1644 Mismatch of mantis number 1449 vs. change description	Revision History
6.1 Errata A	1643 Incorrect row order in GET_EXECUTE_OPERATION_TIMINGS table	Table 18-397
6.1 Errata A	1642 Clarifications and fixes to _PSD and _TSD	Table 5-184
6.1 Errata A	1639 _WPC and _WPP are missing in the Predefined ACPI Names table.	Table 5-164
6.1 Errata A	1616 Clarify which processor ID to use in the EINJ for ARM	Table 18-403
6.1 Errata A	1606 Errata: typos in the Interrupt Resource Descriptor Macro definition	Section 19.6.62
6.1 Errata A	1602 Updates to the PMC Method Result Codes table	Table 10-338
6.1 Errata A	1601 Typos in the _CPC Implementation Example	Section 8.4.7.1.11
6.1 Errata A	1600 Typos in PCC Subspace Structure Type 1 and Type 2.	Table 14-366 and Table 14-367
6.1 Errata A	1599 Add clarification to existing text (_OSC Control Field via arg3)	Table 6-202
6.1 Errata A	1591 ASL grammar clarification for “executable” AML opcodes	Section 5.4
6.1 Errata A	1589 Wireless Power Calibration Device ACPI ID not defined	Section 10.5 (Table 10-292 removed) and Table 5-163
6.1 Errata A	1582 Clarification for Time and Alarm wake description	Section 9.18.1
6.1 Errata A	1581 Processing Sequence for Graceful Shutdown Request - need to update section 6.3.5.1 to reflect change	Table 5-166 and Section 6.3.5.1
6.1 Errata A	1579 typos	Table 5-130 and Table 5-131
6.1 Errata A	1577 BGRT Image Orientation Offset	Table 5-107
6.1 Errata A	1572 Update ASL grammar to support multiple Definition Blocks	Section 19.2.3
6.1 Errata A	1571 Update AML Filename description for ASL DefinitionBlock operator	Section 19.6.28
6.1 Errata A	1552 GIC Redistributor base address language in GICC leaves room for ambiguity	Table 5-60
6.1 Errata A	1549 Errata: wrong offset in Generic Communications Channel Shared Memory Region table.	Table 14-369
6.1	1527 Qualcomm feedback on ACPI 6.1 draft 2	Throughout
6.1	1524 Strange hotlink	Section 5.7.5
6.1	1514 Comments against 6.1 Draft from HPE	Minor corrections and fixed typos throughout document, especially Section 9.20.7.2
6.1	1512 Microsoft feedbacks on ACPI 6.1 draft 2	Section 5.2.25, Section 9.20.7, Section 18.3.2
6.1	1503 Editorial comments against 6.1 Draft 1	Throughout–draft corrections & typos
6.1	1500 ACPI 6.1 - Graceful Shutdown (Device Object Notification)	Table 5-166

continues on next page

Table 2 – continued from previous page

6.1	1499 _FIT and _MAT ASL nits in 6.0 and 6.1 Draft	Section 6.2.10, Section 6.5.9
6.1	1490 ACPI Version update to reflect 6.1 versus 6.0	Table 5-33
6.1	1483 NFIT SPD extensions and clarifications	Section 5.2.25x, Section 6.5.9, Section 9.20x
6.1	1478 Wireless Power Calibration ACPI Device	Section 10.5 & Section 10.6
6.1	1427 Addition to Memory Device State Flags in NFIT	Table 5-133
6.1	1395 _DSM interfaces associated with NVDIMM-N objects	Section 9.20.2x through Section 9.20.7
6.1	1384 ERST/EINJ max wait time	Table 18-397, Table 18-404
6.1	1367 Interrupt-signaled Events	Section 4.1.1.1 Section 5.6, , Section 5.6.10, Section 5.6.4, Section 5.6.5 Section 5.6.5.2, Section 6.2.11.2, Section 7.3.13, Section 18.3.2.7.2, Section 18.4, and added
6.1	1356 ARM APEI extensions	Section 18.3.2.7, Section 18.3.2.8, Section 18.3.2.9
6.1	1326	Section 2.2, Table 5-37, Section 7.4.2.5, Section 15, Table 15-374, Section 16.1.4
6.0 Errata	1488 Typo on description of PkgLength encoding (ACPI v6.0, section 5.4)	Section 5.4
6.0 Errata	1487 The Length of GIC ITS Structure is wrong	Table 5-66
6.0 Errata	1470 Region Format Interface Code clarification	Table 5-137
6.0 Errata	1462 5.2.21 Errata	Section 5.2.21
6.0 Errata	1461 5.2.21.10 Clarification	Section 5.2.21.10
6.0 Errata	1449 Graceful Shutdown Request (Device Object Notification Values)	Section 2.1, Table 5-44, Section 5.2.12.6, Table 5-51, Section 5.2.12.9, Section 5.2.12.14 through Section 5.2.12.18, Section 5.2.25, Section 5.6, Table 6-193, Table 6.2.10, Table 6-249, Table 6.5.9
6.0 Errata	1445 Section 19.6.99 “Package” of the specification needs updating	Section 19.6.100
6.0 Errata	1444 GTDT CntReadBase Physical address should be optional	Section 5.2.24
6.0 Errata	1433 Time and Alarm _GCP changes in support of wakes from S4/S5	Section 9.18.2
6.0 Errata	1432 Errata - Explicit Data Type Conversions	Section 19.3.4, Section 19.3.5.2, Section 19.3.5.3
6.0 Errata	1406 NFIT RAMDisk Update	Section 5.2.25.2
6.0 Errata	1403 Two distinct definitions of the MADT have the same revision number	Table 5-43
6.0 Errata	1393 In FADT: if X_DSMT field is non-zero, DSDT field should be ignored or deprecated	Table 5-33
6.0 Errata	1392 Incorrect length in the GIC ITS Structure	Table 5-66
6.0 Errata	1386 Clarify APEI vs UEFI runtime variable support	Table 18-397
6.0 Errata	1385 ACPI 6.0 typo and table misnumbering	Section 18.5.2.1
6.0 Errata	1380 Unnecessary restrictions to FW vendors in ordering of GIC structures in MADT	Section 5.2.12.14
6.0 Errata	1378 Duplication of table 5-155/156, section mismatch in GIC redistributor	Table 5-175 & Table 5-180 duplicates removed, Section 5.2.12.17

continues on next page

Table 2 – continued from previous page

6.0 Errata	1374 section mismatch: _CCA method belongs to section 6.2 Device Configuration Objects?	Table 6-189/Table 6-193
6.0 Errata	1372 Fix inconsistency for _PXM method in section 17	Section 17.2.1, Section 17.3.2
6.0 Errata	1368 Various errata fixes and clarifications in chapter 18 APEI	Section 18.3.1, Section 18.3.2.7.1, Section 18.5.1, Section 18.6.1, Section 18.6.2, Section 18.6.4
6.0 Errata	1361 Clarify _PIC Method on ARM	Section 5.8.1
6.0 Errata	1289 replace use of the term “BIOS” with more accurate descriptions	Throughout spec
6.0 Errata	1154 Ensure that ACPI and UEFI specs agree on the treatment of “holes” in the memory map	Section 15.4
6.0	1344 Sharing of Connection Resources, NOTE: The changes were included in ACPI 6.0, but was missed in the ACPI 6.0 Revision History	Section 5.5.2.4.6 through Section 5.5.2.4.6.3.9 Section 19.6.15
6.0	1370 Changes needed for ACPI 6.0: persistent memory S4 behavior	Section 16.3.4
6.0	1359 Vendor Range for E820 Address Types and UEFI memory Types	Table 15-374
6.0	1354 Disambiguation of _REV	Section 5.7.4
6.0	1343 Comments against v6.0 Final Draft	Section 18.6.2, Section 18.6.4
6.0	1340 comment against the Final Draft: Minor errata in register fields of LPI example	Section 8.4.4.3.4
6.0	1332 Fixes for ACPI 6.0 Draft March 2	Table 5-37, Section 5.2.25.2, Table 5-132
6.0	1328 ACPI 6.0 Draft feedback - Mantis 1228	Table 5-62
6.0	1337 Missing reference in Extended Address Space Descriptor Definition, Section 6.4.3.5.4	Section 6.4.3.5.4
6.0	1333 ACPI 6.0 March2 Draft Feedback - Bits and NFIT related	NFIT throughout
6.0	1329 ACPI 6.0 Feb 18 Draft - Follow consistent notation for Bits and Bytes ranges	throughout
6.0	1327 ACPI 6.0 Feb 18 draft feedback - NFIT related	NFIT throughout
6.0	1324 ACPI 6.0 Feb 5 Draft1 Feedback2 - Mantis 1250	Section 5.2, Section 5.2.25, Section 6.1.1, Section 5.6.6
6.0	1320 ACPI 6.0 Feb 5 Draft1 Feedback - Mantis 1250	Section 5.2, Section 5.2.25, Section 6.1.1, Section 5.6.6
6.0	1319 Comment against ACPI 6.0 Draft 1 concerning Mantis 1279	Section 19.1, Section 19.6.3, Section 19.6.5, Section 19.6.26, Section 19.6.31, Section 19.6.60, Section 19.6.61Section 19.6.68 - Section 19.6.74, Section 19.6.78Section 19.6.85, Section 19.6.86, Section 19.6.92
6.0	1312 Add USB-C Connection support to _UPC	Table 9-293, Section 9.14
6.0	1306 New ACPI Version Placeholder	Table 5-33
6.0	1302 Errata on reference in section 6.2.11.2 Platform-Wide OSPM Capabilities	Section 6.2.11.2
6.0	1294 Typo in section 5.7.2: “Section” used when “Table” was meant	Section 5.7.2
6.0	1293 Reserve “STAO” and “XENV” table signatures	Table 5-30
6.0	1292 A Missing space in first paragraph of Section 2.4	Section 2.4

continues on next page

Table 2 – continued from previous page

6.0	1284 Battery ACPI ECR	Section 5-184, Section 10.2.2.7, Table 10-329, Section 10.2.2, Table 10-331
6.0	1282 AML: Improve Disassembly of Control Method Invocations	Section 19.6.44, Section 20.2.5.2, Section 20-440
6.0	1281 ASL Printf and Fprintf Debug Macros Table 10-331 Table 10-331	Section 19.2.5, Section 19.2.6, Section 19.3.4, Section 19.3.5.2, Section 19.3, Section 19.4, Section 19.6.52, Section 19.6.107
6.0	1280 ASL Helper Macro for _PLD (Physical Location of Device) - ToPLD()	Section 19.2.6, Section 19.3.4, Section 19.3.5.2, Section 19.4, Section 19.5, Section 19.6.140
6.0	1279 ASL Extensions for Symbolic Operators and Expressions (ASL 2.0)	Section 19.1, Section 19.6.3, Section 19.6.5, Section 19.6.26, Section 19.6.31, Section 19.6.60, Section 19.6.61, Section 19.6.68 - Section 19.6.74, Section 19.6.78, Section 19.6.85, Section 19.6.86, Section 19.6.92
6.0	1265 Missing word in figure 1-1	Figure 1-1
6.0	1264 Device Power Management Clarifications	Section 2.3, Section 2.3.1, Section 3.3.1, Section 3.3, Section 3.4, Section 3.4.2, Section 3.4.3, Section 3.4.3, Section 3.4.4x), Section 7, Section 7.1, Section 7.2x, Section 7.3
6.0	1262 New Thermal Zone Objects	Table 5-184, Section 11.1.5.1, Section 11.4.8, Section 11.4.21
6.0	1261 _OSC, add OS->Platform information to communicate >16 p-states are supported	Table 6-200
6.0	1258 Standby Thermal Trip	Section 11.4.5
6.0	1253 Clarification of S5 (Soft-Off) and S1~S4 Sleeping States	Section 2.4, Section 3.9.4, Section 4.7, Section 4.8.2.3, Section 4.8.3.2.1, Section 7.3.1
6.0	1252 Incorrect Indentation in first page of Section 3	Section 3
6.0	1250 Support for Non-Volatile Memory Firmware Interfaces	Section 5.2, Section 5.2.25, Section 6.1.1, Section 5.6.6
6.0	1241 PCC and level interrupts for HW reduced platforms	Section 14.1.2, Section 14.1.5
6.0	1232 Deprecate Processor Keyword	Table 5-46, Table 5-52, Section 5.2.12.10, Section 5.2.12.12, Section 8.4, Section 11.7.1, Section 11.7.2, Section 19.6.30, Section 19.6.108
6.0	1231 Adjust max p-states	Section 2.6
6.0	1230 Adding Support for Faster Thermal Sampling	Table 6-200, Table 5-184, Section 11.4.17, Section 11.4.22, Section 11.6
6.0	1229 Reserve IORT and support for ARM GICv3/4 ITS in MADT	Table 5-29, Table 5-45, Section 5.2.12.18
6.0	1206 Clarify _HID/_CID/_CLS usage model	Section 6.1, Section 6.1.5, Section 6.2x
6.0	1203 CPPC heterogeneous performance capabilities	Section 8.4.7, Section 8.4.7.1.10
6.0	1197: MADT Efficiency Classes and wording change for MP Parking update	Table 5-60

continues on next page

Table 2 – continued from previous page

6.0	1176 FADT Hypervisor Vendor Identification Support	Table 5-33
6.0	1171 Extend Address Ranger Types and UEFI Memory Type to comprehend persistent memory.	Table 5-37, Section 6.4.3.5.4.1, Section 15, Table 15-379, Section 15.4, Table 15-380
6.0	1152 Support for Platform-specific device reset	Section 7.3.25 and Section 7.3.26 t, Table 7-255 Table 7-256
6.0	1132 Generic Button(s) Abstraction	Table 5-183, Add new Section 9.19 and following
6.0	1125 ACPI Low Power Idle Table (LPIT) and _LPD proposal	Section 5.6.7, Section 5.6.8, Table 6-200, Section 7.1, Section 7.2.5, Section 7.4.2.1, Section 8.4, Section 8.4.1, Section 8.4.2, Section 8.4.2.1, Section 8.4.3.1
5.1 Errata	1265 Missing word in figure 1-1	Figure 1-1
5.1 Errata	1252 Incorrect Indentation in first page of Section 3	Section 3
5.1 Errata	1243 Clarify whether or not the FACS is optional or not	Section 5.2.9, Table 5-33
5.1 Errata	1233 Fix broken Link and Example for _CLS	Section 6.1.3
5.1 Errata	1228 Present GIC version in MADT table	Table 5-62
5.1 Errata	1196 Table reference in Section 9.8.3.2 is Incorrect	Section 9.9.3.2
5.1 Errata	1193 Parking protocol field link is incorrect	Section 5.2.12.14, Table 5-60
5.1 Errata	1190 Table references in Section 18 - ACPI Platform Error Interfaces (APEI) are incorrect	Table 18-383, Table 18-385
5.1 Errata	1189 _CCA attribute default value description does not work for ARM systems	Section 6.2.17
5.1	1181 MADT GICC table definition is wrong	Table 5-61, 5.2.12.14
5.1	1180 FADT minor version byte length is wrong	May-34
5.1	1179 Errors in GTDT Section of 5.1 draft	5.2.24, 5.2.24.1, Tables 5-115, 5-118, 5-121, 5-122
5.1	1175 Bad section reference in ACPI 5.1	19.2.3
5.1	1164 Modifications to UEFI Forum ownership of PNP ID and ACPI ID Registry	6.1.5
5.1	1161 Misc typos in draft documents	5.2.1.6, 5.2.16.4, 5.2.24, 5.2.12.14, 5.2.24.1.1, Table 5-74, Table 5-115-116, Table 5-118-119, Table 5-121, Table 5-61, 5-61 8.4.5.1, 8.4.5.1.2.3 Table 6-162, Table 8-229, RM duplicates from 1123/1130:8.4.5.1.31.1
5.1	1160 ACPI 5.1 draft corrections related to _DSD (SEE #1126)	6.2.5, Table 5-148 & 6-157
5.1	1157 Reserve ACPI Low Power Idle Table Signature “LPIT”	Table 5-31
5.1	1155 Updates to M1133 MADT	Table 5-63, 5-64
5.1	1151 Bug in ASL example code	PRT3 code example following Figure 9-49
5.1	1149 GTDT changes for new GT Configurations	5.2.24, 5.24.1x
5.1	1136 Add a Notification Type for System Resource Affinity Change Event	Table 5-119 Device Object Notifications, new 17.2.2
5.1	1134 FADT changes for PSCI Support on ARM platforms	Table 5-34, 5-36, New table 5-37
5.1	1135 PCC Doorbell Protocol for HW-Reduced Platforms	14.1.1, 14.1.2-4, 14.2.1-2, 14.3-4

continues on next page

Table 2 – continued from previous page

5.1	1133 MADT Updates for new GICs	5.2.12.15-17, Table 5-43, 5.2.12 table 5-45, 5-60, 5-61, 5-63, 5-66
5.1	1131 Per-device Cache-coherency Attribute	6.2, 6.2.16, Was Table 6-142→Table 6-153
5.1	1126 Add _DSD Predefined Object– “DeviceSpecific Data” properties	Was Table 5-133 & 6-142 now→5-148 & 6-157
5.1	1123 CPPC Performance Feedback Counter Change, 1130 CPPC2, [overlapping/duplicate tickets]	Tables 5-126, 8.4.5, 8.4.5.1x , 8.4.5.1, 8.4.5.1.3.1-4
5.1	1116 Add x2APIC and GIC structure for _MAT method	6.2.10
5.0 B	1145 Support GICs in proximity domain	5.2.16 5.2. new section 16.4 new tables, 6.2.13 Table 5-65
5.0 B	1144 Fix the gap for Notify value description	5.6.6, new tables: Table 5-132, 5-133
5.0 B	1142 Error Source Notifications	18.3.2.6.2, 18.4, Table 18-290
5.0 B	1117 Move http://acpi.info/links.htm content to UEFI Forum Website	1.10, 5.2.4, 5.2.22.3, 5.2.24, 5.6.7, 9.8.3.2, 13, 13.2.2 A.2.4, A.2.5, Tables 5-31, 5-60, 5-133
5.0 B	1113 Typos in ACPI 5.0a	Table 6-184
5.0 B	1148 Inconsistent BIX object description/example	Was Table 10-234→10-250
5.0 B	1143 Typos in ACPI 5.0a	6.1.8, 8.4.1
5.0 B	1102 Clarify Use of GPE Block Devices in Hardware-Reduced ACPI	3.11.1, 4.1, 9.10
5.0 B	Mantis 1114 Lack of description on Bit 4 of _STA	6.3.7
5.0 A	Jira 51 incorrect type information	Table 19-322
5.0 A	Jira 50 Misspelling of “management”	3.1
5.0 A	Jira 49 Updated description of DerefOf to specify behavior when attempt is made to de-reference a reference (via Index) to a NULL (empty) package element.	19.5.29
5.0 A	Jira 48 Text changes to change PM Timer from required to optional	4.8.1.4, 4.8.2.1, 4.8.3.3, 5.2.9
5.0 A	Jira 46 Figure 5-29 is a printer killer	Fig 5-29
5.0 A	Jira 45 Typos in Figure 5-30	Fig 5-30
5.0 A	Jira 44 Link issues in table 5-133	Table 5-133
5.0 A	Jira 43 Invalid AddressSpaced keywords in example ASL code, orphan _REG	6.5.4
5.0 A	Jira 42 Serious bug in ASL example code for _OSC	6.2.10.4
5.0 A	Jira 41 Fix problems with PCC address space description	14.5
5.0 A	Jira 40 Issues with _GRT and _SRT Buffer description	9.18.3, 9.18.4
5.0 A	Jira 39 Clarification needed for _CST	Table 8-206
5.0 A	Jira 38 Incorrect field name in “Generic Register Descriptor”.	6.4.3.7
5.0 A	Jira 37 Clarifications for _CPC method	8.4.5.1.2.1-2
5.0 A	Jira 36 Restore legality of module-level executable AML code.	19.1.3
5.0 A	Jira 35 ASL grammar: “UserTerm” is confusing	19.1
5.0 A	Jira 34 Description of _GTM has a bad line with very large font	9.8.2.1.1
5.0 A	Jira 33 Missing information in _CPC description	8.4.5.1
5.0 A	Jira3 2 Error in description of _REG method	6.5.4
5.0 A	Jira 31 Clarify length field for Serial resource descriptor	6.4.3.8.2, Table 6-190

continues on next page

Table 2 – continued from previous page

5.0 A	Jira 30 Argument descriptions in incorrect order for resource descriptors	19.5.41, 19.5.101
5.0 A	Jira 29 Issues with memory descriptors (grammar and macros)	19.1, 19.5
5.0 A	Jira 28 Problems with ASL grammar entry for DWord-Memory	19.1.8
5.0 A	Jira 27 Problems with Unicode description for _MLS method	6.1.7
5.0 A	Jira 26 Incorrect grammar for “32-bits” and “64-bits”	Throughout spec
5.0 A	Jira 25 Incorrect table reference in 19.2.5.4	19.2.5.4
5.0 A	Jira 24 Resource Descriptor tables – formatting issues	6.4
5.0 A	Jira 23 Interrupt Descriptors: Wake bit should be split from Share bit	6.4
5.0 A	Jira 22 ASL grammar for ObjectType operator is incorrect	19.1.6
5.0 A	Jira 21 ASL grammar is missing description of type 6 opcodes	19.1.5
5.0 A	Jira 20 Problems with table 5-31 (reserved ACPI table signatures)	Table 5-31
5.0 A	Jira 19 Clarify description of _BQC method	B.5.4
5.0 A	Jira 18 Fix for EC OpRegion availability example	5.2.15
5.0 A	Jira 17 Clarify meaning of BGRT status field	Table 5-97
5.0 A	Jira 16 Correction to _DSM example	9.14.1
5.0 A	Jira 15 Clarify _DSM backward compatibility requirement and example	9.15.1
5.0 A	Jira 14 Description of _CPC is missing definition of unsupported optional registers	8.4.5.1
5.0 A	Jira 13 Incorrect _PLD name expansion	Table 5-133, 6.1.8
5.0 A	Jira 12 PLD description needs clarification	6.1.8
5.0 A	Jira 11 Errata forwarded from HP	5.2.24, 5.6.5.3
5.0 A	Jira 10 More issues with ACPI table 5-133	Table 5-133
5.0 A	Jira 7 Error in QWordIO, ExtendedIO descriptions	19.5.41, 19.5.101
5.0 A	Jira 6 Appendix A is now misnamed in ACPI 5.0	Appendix A
5.0 A	Jira 5 PARTIAL–Need group agreement–Method _GTS and _BFS are unused, should be removed from ACPI spec.	7.3, 7.3.3, 16.1, 16.1.6-7, fig. 7-204
5.0 A	Jira 4 Table 5-133 - issues with _Sx methods	Table 5-133
5.0 A	Jira 3 Issues with predefined names table (table 5-133)	Table 5-133
5.0 A	Jira 2 Description of new sleep control register incorrect	Table 4-24
5.0 A	Jira 1 SystemCMOS keyword inconsistencies	Table 5-114, 5.5.2.4.1, 6.5.4 19, 5.96, 9.15.1-2, 19.5.96, 20.2.5.2
5.0	Ptec-002	5.2.6
5.0	MSFT-020 Enumeration Power Controls	7.2.7, 7.2.12
5.0	MSFT-019 GTDT table	5.2.24
5.0	MSFT_0018 Locking Targets from AML	5.7.5
5.0	MSFT-0017 PLD clarification for handhelf form factors	5.1.8
5.0	MSFT-0016 Extended GPIO-signaled Event Numbers	5.6.5.3
5.0	MSFT-0015 (0.1) D3 Cold Errata	7.2.1, 7.2.18 through 7.2.22
5.0	MSFT-0014	5.2.23
5.0	MSFT-0013 _ADR for SIO	6.2
5.0	MSFT-0012 ROM (Get ROM Data)	5.6.6, 9.16

continues on next page

Table 2 – continued from previous page

5.0	MSFT-010 Reserved Table Signatures	5.2.6
5.0	MSFT-0009 (0.4)TimeAndAlarmDevice Modification	9.18
5.0	MSFT-0008 Collaborative Processor Performance Control	8.4.5
5.0	MSFT-0007 Platform Communications Channel added (new ch. 14)	Ch 14 (new)
5.0	MSFT-0007-0008 Platform Communication Channel and CPPC changes	Ch 14 (new)
5.0	MSFT-0006 SPB Abstraction	3.11.3, 5.5.2.4.5.x, 6.4.3.8.2, 6.5.8, 18.1.3, 18.1.6, 18.1.7, 18.5.44, 18.5.x, 19.2.5.2
5.0	MSFT-0005 GPIO Abstraction	5.5.2.4.x, 5.6, 5.6.5.x, 6.4.3, 6.3.8.x, 18.5.51, 18.5.52, 18.5.89
5.0	MSFT-0004 (0.2) Fixed DMA Descriptor	6.4.2.9, 18.5.50
5.0	MSFT-0003 Device identification	6.1, 6.1.3, 6.1.5, 6.1.6, 6.1.9
5.0	MSFT-0002 Interrupt Descriptors for Generic Interrupt Controller	5.2.11, 5.2.14-15
5.0	MSFT-0001 HW-reduced ACPI	3.11.x, 4, 4.1.x, 4.3.7, 5.2.9, 5.2.9.1, 6.4.2.1, 6.4.3.6, 7.2.11, 7.3.4, 9.6, 12, 12.1, 12.6, 12.11, 12.11.1, 15, 15.1.x, 15.3, 15.3.1.x, 18.5.55, 18.5.57
5.0	INTC-0014 Remove a line (reference) not needed	A.2.3
5.0	INTC-0013	n/a
5.0	INTC-0012 fix AML opcode table	19.3
5.0	INTC-0011 fix table offsets	18.6.x (tables)
5.0	INTC-0010 Update Constant Descriptions	18.5.88, 18.5.89, 18.5.104, 18.5.136
5.0	INTC0009 RASF	5.2.20.x
5.0	INTC-008	5.2.6
5.0	INTC-006 Fixed Example	6.2.10.4
5.0	INTC-005 Update Package Description	18.5.92
5.0	INTC-004 Table Definition Language	20, 21.x
5.0	INTC-003 MPST	6.1, 6.1.3, 6.1.5, 6.1.6, 6.1.9
5.0	INTC-002 EINJ	17.6.1, 17.6.3, 17.6.5
5.0	INTC-001 (0.8) Firmware Performance Data Table (FPDT)	5.2.20.4, 5.2.20.6
5.0	INTC-001 Firmware Performance Data Table (FPDT) (0.4)	5.2.19- 5.2.20.6
5.0	HP-0002 Additional Hardware Error Notification Types	18.3.2.7
5.0	HP-0001 (0.2) BMC Requested Graceful Shutdown	5.6.5, 6.3.5
5.0	ACPI4.0 _DSM function 0 clarification	9.14.1
5.0	AMD-002 0.3 ROM (Get ROM Data)	B.3.3
4.0a	Errata corrected and clarifications added.	2.2, 5.2.6, 5.2.12.4, 5.2.18, 5.5.2.4.3.1, 5.6.5, 5.6.6, 5.6.7, 6.4.2.8, 6.4.3.5.1-3, 6.5.7, 8.4.3.4, 8.4.4.5, 8.4.5, 9.2.5, 9.8.2.1.1, 9.10, 9.13, 10.4.1, 10.1.3.1, 10.2.2, 10.2.1.1-2, 10.2.2.8, 10.2.2.9, , 10.3, 10.3.3, 10.4, 10.3.4, 10.4.1, 10.5, 15.1, 17.1, 17.3.1, 17.3.2.6.1, 17.3.2.6.2, 17.4, 17.5.1.1, 17.6.1, 17.6.3, 18.1.8, 18.5.44, 18.5.89, 18.5.101

continues on next page

Table 2 – continued from previous page

4.0	Major specification revision. Clock Domains, x2APIC Support, Logical Processor Idling, Corrected Platform Error Polling Table, Maximum System Characteristics Table, Power Metering and Budgeting, IPMI Operation Region, USB3 Support in _PLD, Re-evaluation of _PPC acknowledgement via _OST, Thermal Model Enhancements, _OSC at _SB, Wake Alarm Device, Battery Related Extensions, Memory Bandwidth Monitoring and Reporting, ACPI Hardware Error Interfaces, D3hot.	n/a
3.0b	Errata corrected and clarifications added.	n/a
3.0a	Errata corrected and clarifications added.	n/a
3.0	Major specification revision. General configuration enhancements. Inter-Processor power, performance, and throttling state dependency support added. Support for > 256 processors added. NUMA Distancing support added. PCI Express support added. SATA support added. Ambient Light Sensor and User Presence device support added. Thermal model extended beyond processor-centric support.	n/a
2.0c	Errata corrected and clarifications added.	n/a
2.0b	Errata corrected and clarifications added.	n/a
2.0a	Errata corrected and clarifications added. ACPI 2.0 Errata Document Revision 1.0 through 1.5 integrated.	n/a
2.0 Errata Rev. 1.5	Errata corrected and clarifications added.	n/a
2.0 Errata Rev. 1.4	Errata corrected and clarifications added.	n/a
2.0 Errata Rev. 1.3	Errata corrected and clarifications added.	n/a
2.0 Errata Rev. 1.2	Errata corrected and clarifications added.	n/a
2.0 Errata Rev. 1.1	Errata corrected and clarifications added.	n/a
2.0 Errata Rev. 1.0	Errata corrected and clarifications added.	n/a
2.0	Major specification revision. 64-bit addressing support added. Processor and device performance state support added. Numerous multiprocessor workstation and server-related enhancements. Consistency and readability enhancements throughout.	n/a
1.0b	Errata corrected and clarifications added. New interfaces added.	n/a
1.0a	Errata corrected and clarifications added. New interfaces added.	n/a
1.0	Original Release.	n/a

Overview

The following provides a high-level overview of the Advanced Configuration and Power Interface (ACPI). To make it easier to understand ACPI, this section focuses on broad and general statements about ACPI and does not discuss every possible exception or detail about ACPI. The rest of the ACPI specification provides much greater detail about the inner workings of ACPI than is discussed here, and is recommended reading for developers using ACPI.

History of ACPI

ACPI was developed through collaboration between Intel, Microsoft*, Toshiba*, HP*, and Phoenix* in the mid-1990s. Before the development of ACPI, operating systems (OS) primarily used BIOS (Basic Input/Output System) interfaces for power management and device discovery and configuration. This power management approach used the OS's ability to call the system BIOS natively for power management. The BIOS was also used to discover system devices and load drivers based on probing input/output (I/O) and attempting to match the correct driver to the correct device (plug and play). The location of devices could also be hard coded within the BIOS because the platform itself was non-enumerable. These solutions were problematic in three key ways. First, the behavior of OS applications could be negatively affected by the BIOS-configured power management settings, causing systems to go to sleep during presentations or other inconvenient times. Second, the power management interface was proprietary on each system. This required developers to learn how to configure power management for each individual system. Finally, the default settings for various devices could also conflict with each other, causing devices to crash, behave erratically, or become undiscoverable.

ACPI was developed to solve these problems and others.

What is ACPI?

ACPI can first be understood as an architecture-independent power management and configuration framework that forms a subsystem within the host OS. This framework establishes a hardware register set to define power states (sleep, hibernate, wake, etc). The hardware register set can accommodate operations on dedicated hardware and general purpose hardware.

The primary intention of the standard ACPI framework and the hardware register set is to enable power management and system configuration without directly calling firmware natively from the OS. ACPI serves as an interface layer between the operating system and system firmware, as shown in figure i-1.

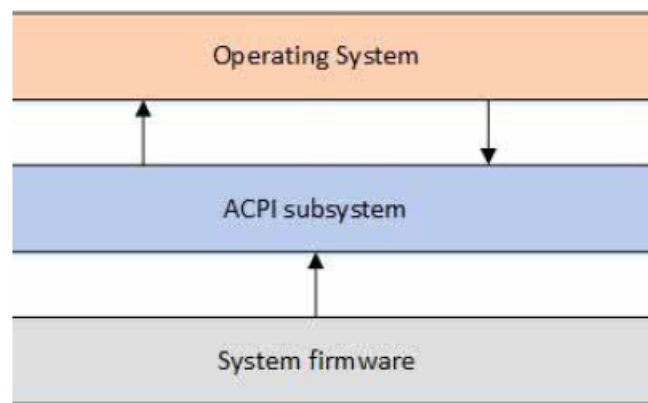

Fig. 1: Fig. i-1 - ACPI overview

ACPI defines two types of data structures that are shared between system firmware and the OS via the ACPI subsystem: data tables and definition blocks (see figure i-2). These data structures are the primary communication mechanism between the firmware and the OS. Data tables store raw data and are consumed by device drivers. Definition blocks consist of byte code that is executable by an interpreter.

Upon initialization, the AML interpreter extracts byte code in the definition blocks as enumerable objects. This collection of enumerable objects forms an OS construct called the ACPI namespace. Objects in the ACPI namespace

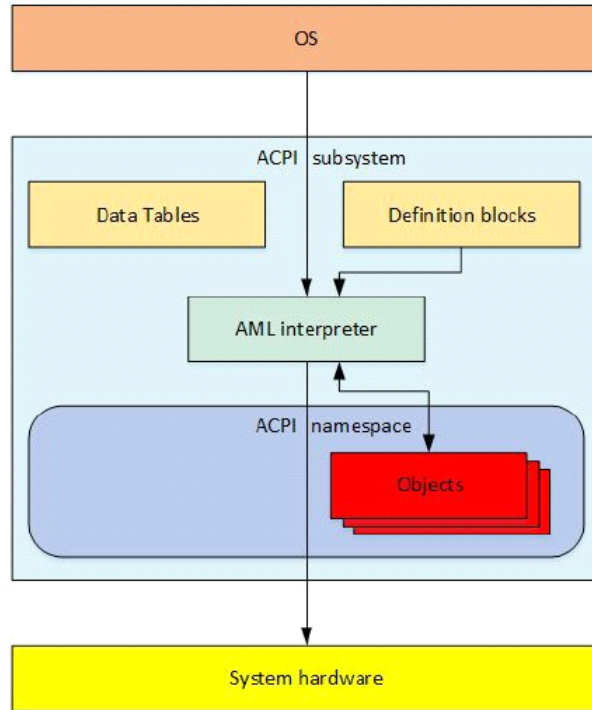

Fig. 2: Fig. i-2 - ACPI Structure

can either have a directly defined value, or be evaluated by the AML interpreter. The AML interpreter, directed by the OS, evaluates objects and then interfaces with system hardware to perform necessary operations.

The definition block byte code is compiled from the ACPI Source Language (ASL) code. ASL is the language used to define ACPI objects and to write control methods. An ASL compiler translates ASL into ACPI Machine Language (AML) byte code. AML is the language processed by the AML interpreter, as shown in figure i-3.

ACPI Source Language (ASL) code is used to define objects and control methods. Then the ASL compiler translates ASL into ACPI Machine Language (AML) byte code contained within ACPI definition Blocks. Definition blocks consist of an identifying table header and byte code that is executable by an AML interpreter.

The AML interpreter executes byte code and evaluates objects in the definition blocks to allow the byte code to perform loop constructs, conditional evaluations, access defined address spaces, and perform other operations that applications require. The AML interpreter has read/write access to defined address spaces, including system memory, I/O, PCI configuration, and more. It accesses these address spaces by defining entry points called objects. Objects can either have a directly defined value or else must be evaluated and interpreted by the AML interpreter.

This collection of enumerable objects is an OS construct called the ACPI namespace. The namespace is a hierarchical representation of the ACPI devices on a system. The system bus is the root of enumeration for these ACPI devices. Devices that are enumerable on other buses, like PCI or USB devices, are usually not enumerated in the namespace. Instead, their own buses enumerate the devices and load their drivers. However, all enumerable buses have an encoding technique that allows ACPI to encode the bus-specific addresses of the devices so they can be found in ACPI, even though ACPI usually does not load drivers for these devices.

Generally, devices that have a `_HID` object (hardware identification object) are enumerated and have their drivers loaded by ACPI. Devices that have an `_ADR` object (physical address object) are usually not enumerated by ACPI and generally do not have their drivers loaded by ACPI. `_ADR` devices usually can perform all necessary functions without involving ACPI, but in cases where the device driver cannot perform a function, or if the driver needs to communicate to system firmware, ACPI can evaluate objects to perform the needed function.

As an example of this, PCI does not support native hotplug. However, PCI can use ACPI to evaluate objects and define

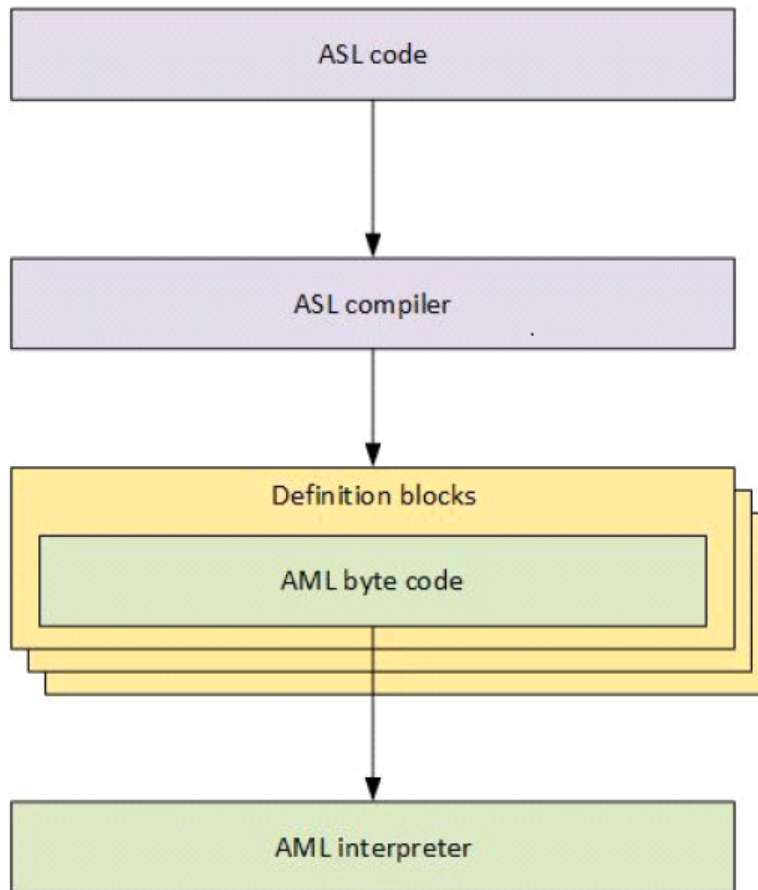

Fig. 3: Fig. i-3 - ASL and AML

methods that allow ACPI to fill in the functions necessary to perform hotplug on PCI.

An additional aspect of ACPI is a runtime model that handles any ACPI interrupt events that occur during system operation. ACPI continues to evaluate objects as necessary to handle these events. This interrupt-based runtime model is discussed in greater detail in the Runtime model section below.

ACPI Initialization

The best way to understand how ACPI works is chronologically. The moment the user powers up the system, the system firmware completes its setup, initialization, and self tests.

The system firmware then uses information obtained during firmware initialization to update the ACPI tables as necessary with various platform configurations and power interface data, before passing control to the bootstrap loader. The extended root system description table (XSDT) is the first table used by the ACPI subsystem and contains the addresses of most of the other ACPI tables on the system. The XSDT points to the fixed ACPI description table (FADT) as well as other major tables that the OS processes during initialization. After the OS initializes, the FADT directs the ACPI subsystem to the differentiated system description table (DSDT), which is the beginning of the namespace because it is the first table that contains a definition block.

The ACPI subsystem then processes the DSDT and begins building the namespace from the ACPI definition blocks. The XSDT also points to the secondary system description tables (SSDTs) and adds them to the namespace. The ACPI data tables give the OS raw data about the system hardware.

After the OS has built the namespace from the ACPI tables, it begins traversing the namespace and loading device drivers for all the `_HID` devices it encounters in the namespace. See figure i-4.

In the ACPI Initialization diagram above, system firmware updates the ACPI tables as necessary with information only available at runtime, before handing off control to the bootstrap loader. The XSDT is the first table used by the OS's ACPI subsystem, and contains addresses of most other ACPI tables on the system. The XSDT points to the FADT, the SSDTs, and other major ACPI tables. The FADT directs the ACPI subsystem to the DSDT, which is the beginning of the namespace because DSDT is the first table that contains a definition block. The ACPI subsystem then consumes the DSDT and begins building the ACPI namespace from the definition blocks. The XSDT also points to the SSDTs and adds them to the namespace.

Runtime Model

After the system is up and running, ACPI works with the OS to handle any ACPI events that occur via an interrupt. This interrupt invokes ACPI events in one of two general ways: fixed events and general purpose events (GPEs).

Fixed events are ACPI events that have a predefined meaning in the ACPI specification. These fixed events include actions like pressing the power button or ACPI timer overflows. These events are handled directly by the OS handlers.

GPEs are ACPI events that are not predefined by the ACPI specification. These events are usually handled by evaluating control methods, which are objects in the namespace and can access system hardware. When the ACPI subsystem evaluates the control method with the AML interpreter, the GPE object handles the events according to the OS's implementation. Typically this might involve issuing a notification to a device to invoke the device driver to perform a function.

We discuss a generic example of this runtime model in the next section.

Thermal Event Example

ACPI includes a thermal model to allow systems to control the system temperature either actively (by performing actions like turning a fan on) or passively by reducing the amount of power the system uses (by performing actions like throttling the processor). We can use an example of a generic thermal event shown in Figure i-5 to demonstrate how the ACPI runtime model works.

The ACPI thermal zone includes control methods to read the current system temperature and trip points.

When the OS initially finds a thermal zone in the namespace, it loads the thermal zone driver, which evaluates the thermal zone to obtain the current temperature and trip points.

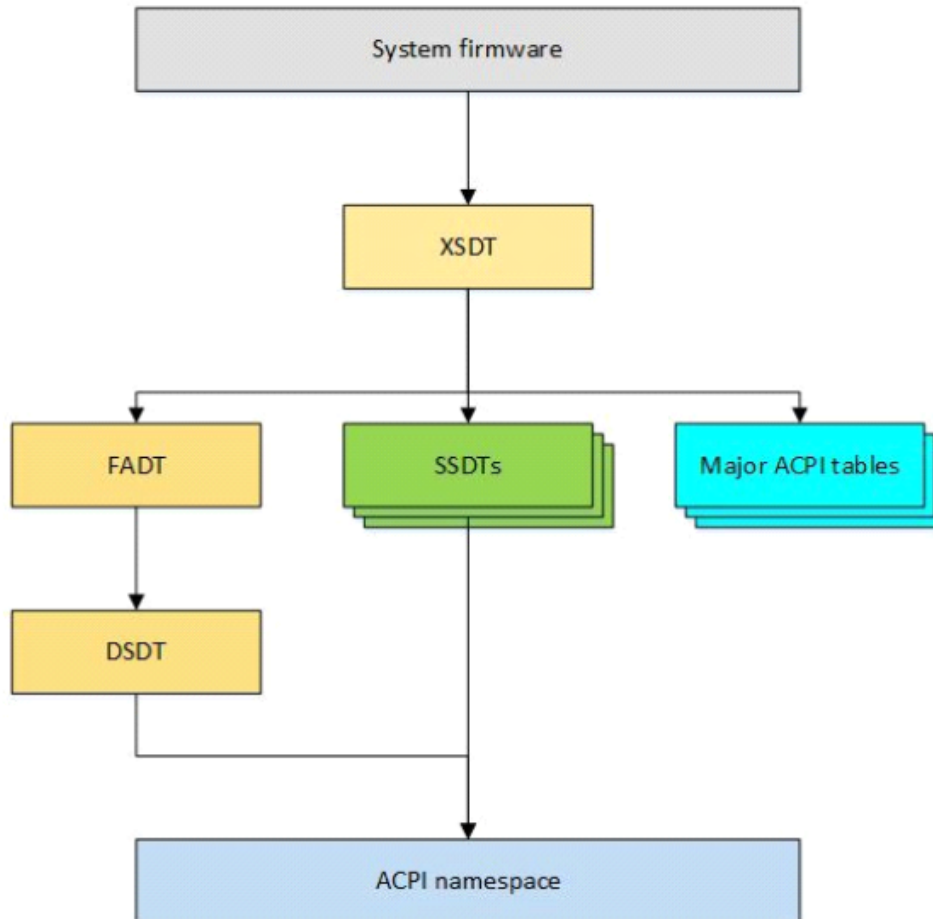

Fig. 4: Fig. i-4 ACPI Initialization

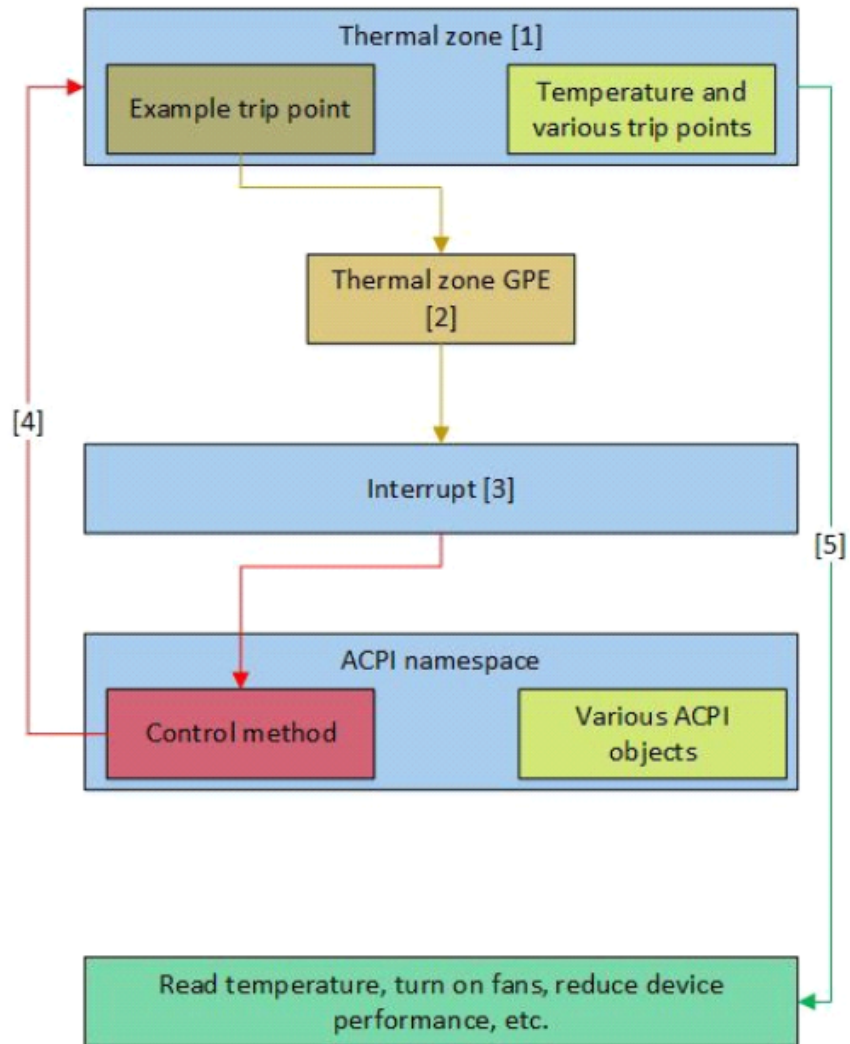

Fig. 5: Fig. i-5 Runtime Thermal Event

When a system component heats up enough to trigger a trip point, a thermal zone GPE occurs.

The GPE causes an interrupt to occur. When the ACPI subsystem receives the interrupt, it first checks whether any fixed events have occurred. In this example, the thermal zone event is a GPE, so no fixed event has occurred.

The ACPI subsystem then searches the namespace for the control method that matches the GPE number of the interrupt. Upon finding it, the ACPI subsystem evaluates the control method, which might then access hardware and/or notify the thermal zone handler.

The operating system's thermal zone handler then takes whatever actions are necessary to handle the event, including possibly accessing hardware.

ACPI is a very robust interface implementation. The thermal zone trip point could notify the system to turn on a fan, reduce a device's performance, read the temperature, shut down the system, or any combination of these and other actions depending on the need.

This runtime model is used throughout the system to manage all of the ACPI events that occur during system operation.

Summary

ACPI can best be described as a framework of concepts and interfaces that are implemented to form a subsystem within the host OS. The ACPI tables, handlers, interpreter, namespace, events, and interrupt model together form this implementation of ACPI, creating the ACPI subsystem within the host OS. In this sense, ACPI is the interface between the system hardware/firmware and the OS and OS applications for configuration and power management. This gives various OS a standardized way to support power management and configuration via the ACPI namespace.

The ACPI namespace is the enumerable, hierarchical representation of all ACPI devices on the system and is used to both find and load drivers for ACPI devices on the system. The namespace can be dynamic by evaluating objects and sending interrupts in real time, all without the need for the OS to call native system firmware code. This enables device manufacturers to code their own instructions and events into devices. It also reduces incompatibility and instability by implementing a standardized power management interface.

INTRODUCTION

The Advanced Configuration and Power Interface (ACPI) specification was developed to establish industry common interfaces enabling robust operating system (OS)-directed motherboard device configuration and power management of both devices and entire systems. ACPI is the key element in Operating System-directed configuration and Power Management (OSPM).

ACPI evolved the existing pre-ACPI collection of power management BIOS code, Advanced Power Management (APM) application programming interfaces (APIs, PNPBIOS APIs, Multiprocessor Specification (MPS) tables and so on into a well-defined power management and configuration interface specification. ACPI provides the means for an orderly transition from existing (legacy) hardware to ACPI hardware, and it allows for both ACPI and legacy mechanisms to exist in a single machine and to be used as needed.

Further, system architectures being built at the time of the original ACPI specification's inception, stretched the limits of historical "Plug and Play" interfaces. ACPI evolved existing motherboard configuration interfaces to support advanced architectures in a more robust, and potentially more efficient manner.

The interfaces and OSPM concepts defined within this specification are suitable to all classes of computers including (but not limited to) desktop, mobile, workstation, and server machines. From a power management perspective, OSPM/ACPI promotes the concept that systems should conserve energy by transitioning unused devices into lower power states including placing the entire system in a low-power state (sleeping state) when possible.

This document describes ACPI hardware interfaces, ACPI software interfaces and ACPI data structures that, when implemented, enable support for robust OS-directed configuration and power management (OSPM).

1.1 Principal Goals

ACPI is the key element in implementing OSPM. ACPI-defined interfaces are intended for wide adoption to encourage hardware and software vendors to build ACPI-compatible (and, thus, OSPM-compatible) implementations.

The principal goals of ACPI and OSPM are to:

- Enable all computer systems to implement motherboard configuration and power management functions, using appropriate cost/function tradeoffs:
 - Computer systems include (but are not limited to) desktop, mobile, workstation, and server machines.
 - Machine implementers have the freedom to implement a wide range of solutions, from the very simple to the very aggressive, while still maintaining full OS support.
 - Wide implementation of power management will make it practical and compelling for applications to support and exploit it. It will make new uses of PCs practical and existing uses of PCs more economical.
- Enhance power management functionality and robustness:

- Power management policies too complicated to implement in platform firmware can be implemented and supported in the OS, allowing inexpensive power managed hardware to support very elaborate power management policies.
- Gathering power management information from users, applications, and the hardware together into the OS will enable better power management decisions and execution.
- Unification of power management algorithms in the OS will reduce conflicts between the firmware and OS and will enhance reliability.
- Facilitate and accelerate industry-wide implementation of power management:
 - OSPM and ACPI reduces the amount of redundant investment in power management throughout the industry, as this investment and function will be gathered into the OS. This will allow industry participants to focus their efforts and investments on innovation rather than simple parity.
 - The OS can evolve independently of the hardware, allowing all ACPI-compatible machines to gain the benefits of OS improvements and innovations.
- Create a robust interface for configuring motherboard devices:
 - Enable new advanced designs not possible with existing interfaces.

1.1.1 Principle of Inclusive Terminology

The UEFI Forum follows a Principle of Inclusive Terminology in building and maintaining content for specifications. This means efforts are made to ensure that all wording is perceived or likely to be perceived as welcoming by everyone regardless of personal characteristics. In some cases, the Forum acknowledges that wording derived from earlier work, for example references to legacy specifications not controlled by the Forum, may not follow this principle. In order to preserve compatibility for code that reads on legacy specifications, particularly where that specification is no longer under maintenance or development, language in this specification may appear out of sync with this principle. The Forum is resolved to work with other standards development bodies to eliminate such examples over time. In the meanwhile, by acknowledging and calling attention to this issue the hope is to promote discussion and action towards more complete use of Inclusive Language reflective of the diverse and innovative population of the technical community that works on standards.

1.2 Power Management Rationale

It is necessary to move power management into the OS and to use an abstract interface (ACPI) between the OS and the hardware to achieve the principal goals set forth above. Because ACPI is abstract, the OS can evolve separately from the hardware and, likewise, the hardware from the OS.

ACPI is by nature more portable across operating systems and processors. ACPI control methods allow for very flexible implementations of particular features.

Issues with older power management approaches include the following:

- Minimal support for power management inhibits application vendors from supporting or exploiting it.
 - Moving power management functionality into the OS makes it available on every machine on which the OS is installed. The level of functionality (power savings, and so on) varies from machine to machine, but users and applications will see the same power interfaces and semantics on all OSPM machines.
 - This will enable application vendors to invest in adding power management functionality to their products.
- Legacy power management algorithms were restricted by the information available to the platform firmware that implemented them. This limited the functionality that could be implemented.

- Centralizing power management information and directives from the user, applications, and hardware in the OS allows the implementation of more powerful functionality. For example, an OS can have a policy of dividing I/O operations into normal and lazy. Lazy I/O operations (such as a word processor saving files in the background) would be gathered up into clumps and done only when the required I/O device is powered up for some other reason. A non-lazy I/O request made when the required device was powered down would cause the device to be powered up immediately, the non-lazy I/O request to be carried out, and any pending lazy I/O operations to be done. Such a policy requires knowing when I/O devices are powered up, knowing which application I/O requests are lazy, and being able to assure that such lazy I/O operations do not starve.
- Appliance functions, such as answering machines, require globally coherent power decisions. For example, a telephone-answering application could call the OS and assert, “I am waiting for incoming phone calls; any sleep state the system enters must allow me to wake and answer the telephone in 1 second.” Then, when the user presses the “off” button, the system would pick the deepest sleep state consistent with the needs of the phone answering service.
 - Platform firmware has become very complex to deal with power management. It is difficult to make work with an OS and is limited to static configurations of the hardware.
 - There is much less state information for the platform firmware to retain and manage (because the OS manages it).
 - Power management algorithms are unified in the OS, yielding much better integration between the OS and the hardware.
 - Because additional ACPI tables (Definition Blocks) can be loaded, for example, when a mobile system docks, the OS can deal with dynamic machine configurations.
 - Because the platform firmware has fewer functions and they are simpler, it is much easier (and therefore cheaper) to implement and support.

1.3 Legacy Support

ACPI provides support for an orderly transition from legacy hardware to ACPI hardware, and allows for both mechanisms to exist in a single machine and be used as needed.

Table 1.1: Hardware Type vs. OS Type Interaction

Hardware/OS	Legacy OS	ACPI OS with OSPM
Legacy hardware	A legacy OS on legacy hardware does what it always did.	If the OS lacks legacy support, legacy support is completely contained within the hardware functions.
Legacy and ACPI hardware support in machine	It works just like a legacy OS on legacy hardware.	During boot, the OS tells the hardware to switch from legacy to OSPM/ACPI mode and from then on, the system has full OSPM/ACPI support.
ACPI-only hardware	There is no power management.	There is full OSPM/ACPI support.

1.4 OEM Implementation Strategy

Any OEM is, as always, free to build hardware as they see fit. Given the existence of the ACPI specification, two general implementation strategies are possible:

- An original equipment manufacturer (OEM) can adopt the OS vendor-provided ACPI OSPM software and implement the hardware part of the ACPI specification (for a given platform) in one of many possible ways.
- An OEM can develop a driver and hardware that are not ACPI-compatible. This strategy opens up even more hardware implementation possibilities. However, OEMs who implement hardware that is OSPM-compatible but not ACPI-compatible will bear the cost of developing, testing, and distributing drivers for their implementation.

1.5 Power and Sleep Buttons

OSPM provides a new appliance interface to consumers. In particular, it provides for a sleep button that is a “soft” button that does not turn the machine physically off but signals the OS to put the machine in a soft off or sleeping state. ACPI defines two types of these “soft” buttons: one for putting the machine to sleep and one for putting the machine in soft off.

This gives the OEM two different ways to implement machines: A one-button model or a two-button model. The one-button model has a single button that can be used as a power button or a sleep button as determined by user settings. The two-button model has an easily accessible sleep button and a separate power button. In either model, an override feature that forces the machine to the soft-off state without OSPM interaction is also needed to deal with various rare, but problematic, situations.

1.6 ACPI Specification and the Structure of ACPI

This specification defines ACPI hardware interfaces, ACPI software interfaces and ACPI data structures. This specification also defines the semantics of these interfaces.

Fig. 1.1 below lays out the software and hardware components for OSPM/ACPI, and how they relate to each other. This specification describes the interfaces between components, the contents of the ACPI System Description Tables, and the related semantics of the other ACPI components. Notice that the ACPI System Description Tables, which describe a particular platform’s hardware, are at heart of the ACPI implementation and the role of the ACPI System Firmware is primarily to supply the ACPI Tables (rather than a native instruction API).

ACPI is not a software specification; it is not a hardware specification, although it addresses both software and hardware and how they must behave. ACPI is, instead, an interface specification comprised of both software and hardware elements.

There are three run-time components to ACPI:

ACPI System Description Tables

Describes the interfaces to the hardware. Some descriptions limit what can be built (for example, some controls are embedded in fixed blocks of registers and the table specifies the address of the register block). Most descriptions allow the hardware to be built in arbitrary ways and can describe arbitrary operation sequences needed to make the hardware function. ACPI Tables containing “Definition Blocks” can make use of a pseudo-code type of language, the interpretation of which is performed by the OS. That is, OSPM contains and uses an interpreter that executes procedures encoded in the pseudo-code language and stored in the ACPI tables containing “Definition Blocks.” The pseudo-code language, known as ACPI Machine Language (AML), is a compact, tokenized, abstract type of machine language.

ACPI Registers

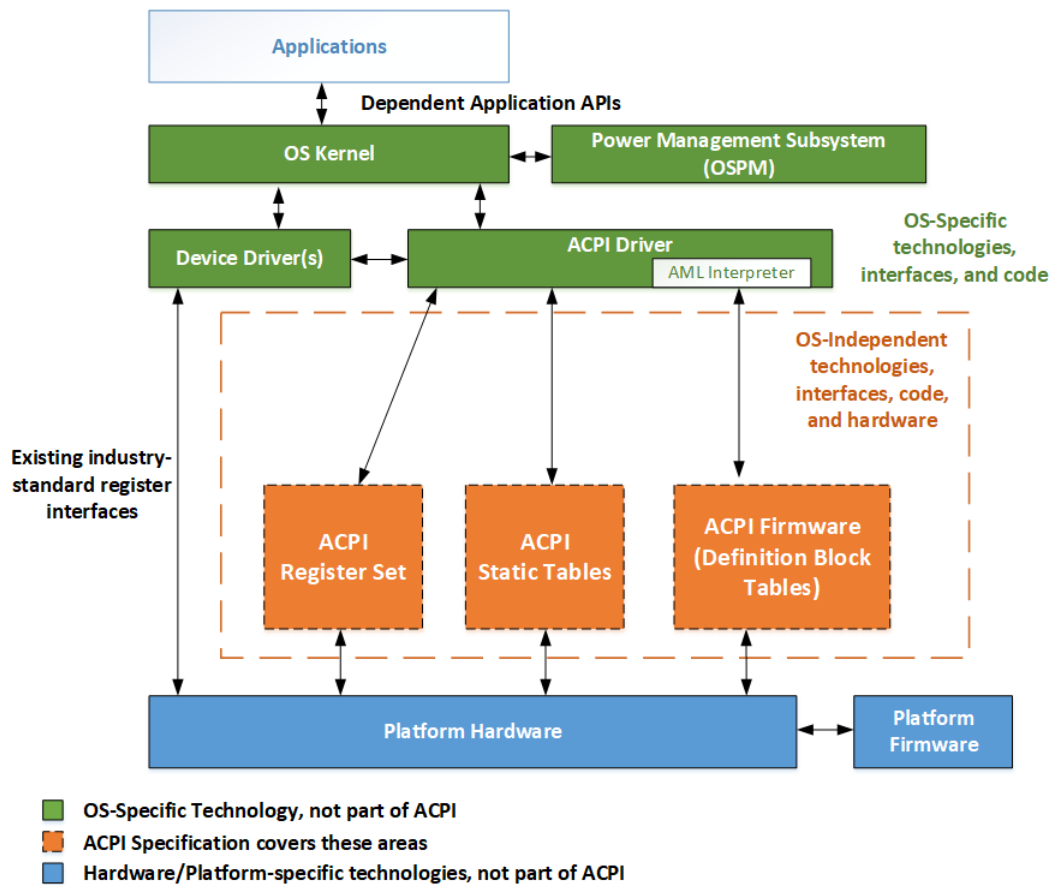

Fig. 1.1: OSPM/ACPI Global System

The constrained part of the hardware interface, described (at least in location) by the ACPI System Description Tables.

ACPI Platform Firmware

Refers to the portion of the firmware that is compatible with the ACPI specifications. Typically, this is the code that boots the machine (as legacy BIOSs have done) and implements interfaces for sleep, wake, and some restart operations. It is called rarely, compared to a legacy BIOS. The ACPI Description Tables are also provided by the ACPI Platform Firmware.

1.7 OS and Platform Compliance

The ACPI specification contains only interface specifications. ACPI does not contain any platform compliance requirements. The following sections provide guidelines for class specific platform implementations that reference ACPI-defined interfaces and guidelines for enhancements that operating systems may require to completely support OSPM/ACPI. The minimum feature implementation requirements of an ACPI-compatible OS are also provided.

1.7.1 Platform Implementations of ACPI-defined Interfaces

System platforms implement ACPI-defined hardware interfaces via the platform hardware and ACPI-defined software interfaces and system description tables via the ACPI system firmware. Specific ACPI-defined interfaces and OSPM concepts while appropriate for one class of machine (for example, a mobile system), may not be appropriate for another class of machine (for example, a multi-domain enterprise server). It is beyond the capability and scope of this specification to specify all platform classes and the appropriate ACPI-defined interfaces that should be required for the platform class.

Platform design guide authors are encouraged to require the appropriate ACPI-defined interfaces and hardware requirements suitable to the particular system platform class addressed in a particular design guide. Platform design guides should not define alternative interfaces that provide similar functionality to those defined in the ACPI specification.

1.7.1.1 Recommended Features and Interface Descriptions for Design Guides

Common description text and category names should be used in design guides to describe all features, concepts, and interfaces defined by the ACPI specification as requirements for a platform class. Listed below is the recommended set of high-level text and category names to be used to describe the features, concepts, and interfaces defined by ACPI.

Note: The definitions and relational requirements of the interfaces specified below are generally spread throughout the ACPI specification:

- *System Address Map Interfaces*
- *ACPI System Description Tables*
- *Root System Description Pointer (RSDP)*
- *System Description Table Header*
- *Root System Description Table (RSDT)*
- *Fixed ACPI Description Table (FADT)*
- *Firmware ACPI Control Structure (FACS)*
- *Differentiated System Description Table (DSDT)*
- *Secondary System Description Table (SSDT)*

- *Multiple APIC Description Table (MADT)*
- *Smart Battery Table (SBST)*
- *Extended System Description Table (XSDT)*
- *Embedded Controller Boot Resources Table (ECDT)*
- *System Resource Affinity Table (SRAT)*
- *System Locality information Table*
- *Corrected Platform Error Polling Table (CPEP)*
- *Maximum System Characteristics Table (MSCT)*
- *ACPI RAS Feature Table (RASf)*
- *ACPI RAS2 Feature Table (RAS2)*
- *Memory Power State Table (MPST)*
- *Platform Memory Topology Table*
- *Boot Graphics Resource Table (BGRT)*
- *Firmware Performance Data Table (FPDT)*
- *Generic Timer Description Table (GTDT)*
- *Fixed ACPI Description Table (FADT)*
- *Power management timer control/status*
- Power or sleep button with S5 override (also possible in generic space)
- Real time clock wakeup alarm control/status
- SCI /SMI routing control/status for Power Management and General-purpose events
- System power state controls (sleeping/wake control)
- Processor power state control (c states)
- Processor throttling control/status
- Processor performance state control/status
- General-purpose event control/status
- Global Lock control/status
- System Reset control
- Embedded Controller control/status
- SMBus Host Controller (HC) control/status
- Smart Battery Subsystem
- ACPI-defined Generic Register Interfaces and object definitions in the ACPI Namespace.
- General-purpose event processing
- Motherboard device identification, configuration, and insertion/removal
- Thermal zones
- Power resource control
- Device power state control

- System power state control
- System indicators
- Devices and device controls:
 - Processor
 - Control Method Battery
 - Smart Battery Subsystem
 - Mobile Lid
 - Power or sleep button with S5 override (also possible in fixed space)
 - Embedded controller
 - Fan
 - Generic Bus Bridge
 - ATA Controller
 - Floppy Controller
 - GPE Block
 - Module
 - Memory
- Global Lock related interfaces
- ACPI Event programming model
- ACPI-defined Platform Firmware Responsibilities
- ACPI-defined State Definitions:
 - Global system power states (G-states, S0, S5)
 - System sleeping states (S-states S1-S4)
 - Device power states (D-states)
 - Processor power states (C-states)
 - Device and processor performance states (P-states)

1.7.1.2 Terminology Examples for Design Guides

The following example shows how a client platform design guide could use the recommended terminology to define ACPI requirements, with a goal of requiring robust configuration and power management for the system class.

Note: This example is provided as a guideline for how ACPI terminology can be used. It should not be interpreted as a statement of ACPI requirements.

Platforms compliant with this platform design guide must implement the following ACPI defined system features, concepts, and interfaces, along with their associated event models:

- System Address Map Interfaces
- ACPI System Description Tables provided in the system firmware
- ACPI-defined Fixed Registers Interfaces:

- Power management timer control/status
- Power or sleep button with S5 override (may also be implemented in generic register space)
- Real time clock wakeup alarm control/status
- General-purpose event control/status
- SCI /SMI routing control/status for Power Management and General-purpose events (control required only if system supports legacy mode)
- System power state controls (sleeping/wake control)
- Processor power state control (for C1)
- Global Lock control/status (if Global Lock interfaces are required by the system)
- ACPI-defined Generic Register Interfaces and object definitions in the ACPI Namespace:
 - General-purpose event processing
 - Motherboard device identification, configuration, and insertion/removal
 - System power state control (Section 7.3)
 - Devices and device controls:
 - * Processor
 - * Control Method Battery (or Smart Battery Subsystem on a mobile system)
 - * Smart Battery Subsystem (or Control Method Battery on a mobile system)
 - * Power or sleep button with S5 override (may also be implemented in fixed register space)
 - Global Lock related interfaces when a logical register in the hardware is shared between OS and firmware environments
- ACPI Event programming model
- ACPI-defined Platform Firmware Responsibilities
- ACPI-defined State Definitions:
 - System sleeping states (At least one system sleeping state, S1-S4, must be implemented)
 - Device power states (D-states must be implemented in accordance with device class specifications)
 - Processor power states (All processors must support the C1 Power State)

The following example shows how a design guide could use the recommended terminology to define ACPI related requirements for systems that execute multiple OS instances, with a goal of requiring robust configuration and continuous availability for the system class.

Note: This example is provided as a guideline for how ACPI terminology can be used. It should not be interpreted as a statement of ACPI requirements.

Platforms compliant with this platform design guide must implement the following ACPI defined system features and interfaces, along with their associated event models:

- System Address Map Interfaces
- ACPI System Description Tables provided in the system firmware
- ACPI-defined Fixed Registers Interfaces:
- Power management timer control/status

- General-purpose event control/status
- SCI /SMI routing control/status for Power Management and General-purpose events
- (control required only if system supports legacy mode)
- System power state controls (sleeping/wake control)
- Processor power state control (for C1)
- Global Lock control/status (if Global Lock interfaces are required by the system)
- ACPI-defined Generic Register Interfaces and object definitions in the ACPI Namespace:
 - General-purpose event processing
 - Motherboard device identification, configuration, and insertion/removal ([Section 6](#))
 - System power state control ([Section 7.3](#))
 - System indicators
 - Devices and device controls:
 - * Processor
- Global Lock related interfaces when a logical register in the hardware is shared between OS and firmware environments
- ACPI Event programming model ([Section 5.6](#))
- ACPI-defined Platform Firmware Responsibilities ([Section 15](#))
- ACPI-defined State Definitions:

Processor power states (All processors must support the C1 Power State)

1.7.2 OSPM Implementations

OS enhancements are needed to support ACPI-defined features, concepts, and interfaces, along with their associated event models appropriate to the system platform class upon which the OS executes. This is the implementation of OSPM. The following outlines the OS enhancements and elements necessary to support all ACPI-defined interfaces. To support ACPI through the implementation of OSPM, the OS needs to be modified to:

- Use *System Address Map Interfaces*.
- Find and consume the ACPI System Description Tables.
- Interpret ACPI machine language (AML).
- Enumerate and configure motherboard devices described in the ACPI Namespace.
- Interface with the power management timer.
- Interface with the real-time clock wake alarm.
- Enter ACPI mode (on legacy hardware systems).
- Implement device power management policy.
- Implement power resource management.
- Implement processor power states in the scheduler idle handlers.
- Control processor and device performance states.
- Implement the ACPI thermal model.

- Support the ACPI Event programming model including handling SCI interrupts, managing fixed events, general-purpose events, embedded controller interrupts, and dynamic device support.
- Support acquisition and release of the Global Lock.
- Use the reset register to reset the system.
- Provide APIs to influence power management policy.
- Implement driver support for ACPI-defined devices.
- Implement APIs supporting the system indicators.
- Support all system states S1-S5.

1.7.3 OS Requirements

The following list describes the minimum requirements for an OSPM/ACPI-compatible OS:

- Use [Section 15](#) to get the system address map on Intel Architecture (IA) platforms:
- INT 15H, E820H - Query System Address Map interface (see [Section 15](#))
- EFI GetMemoryMap() Boot Services Function (see [Section 15](#))
- Find and consume the ACPI System Description Tables (see [Section 5](#)).
- Implementation of an AML interpreter supporting all defined AML grammar elements (see [Section 20](#)).
- Support for the ACPI Event programming model including handling SCI interrupts, managing fixed events, general-purpose events, embedded controller interrupts, and dynamic device support.
- Enumerate and configure motherboard devices described in the ACPI Namespace.
- Implement support for the following ACPI devices defined within this specification:
- Embedded Controller Device (see [Section 12](#))
- GPE Block Device (see [Section 9.9](#))
- Implementation of the ACPI thermal model (see [Section 3.10](#)).
- Support acquisition and release of the Global Lock.
- OS-directed power management support (device drivers are responsible for maintaining device context as described by the Device Power Management Class Specifications described in [Appendix A: Device Class Specifications](#)).

1.8 Target Audience

This specification is intended for the following users:

- OEMs building hardware containing ACPI-compatible interfaces
- Operating system and device driver developers
- All platform system firmware developers
- CPU and chip set vendors
- Peripheral vendors

1.9 Document Organization

The ACPI specification document is organized into the following four parts:

- The first part of the specification (chapters 1 through 3) introduces ACPI and provides an executive overview.
- The second part (chapters 4 and 5) defines the ACPI hardware and software programming models.
- The third part (chapters 6 through 17) specifies the ACPI implementation details; this part of the specification is primarily for developers.
- The fourth part (chapters 18 and 19) is technical reference material: chapter 18 is the ACPI Source Language (ASL) reference, which is referenced by many other sections in this specification.
- Appendices contain device class specifications, describing power management characteristics of specific classes of devices, and device class-specific ACPI interfaces.

1.9.1 ACPI Introduction and Overview

The first three sections of the specification provide an executive overview of ACPI.

Chapter 1: Introduction Discusses the purpose and goals of the specification, presents an overview of the ACPI-compatible system architecture, specifies the minimum requirements for an ACPI-compatible system, and provides references to related specifications.

Chapter 2: Definition of Terms Defines the key terminology used in this specification. In particular, the global system states (Mechanical Off, Soft Off, Sleeping, Working, and Non-Volatile Sleep) are defined in this Chapter, along with the device power state definitions: Off (D3), D3hot, D2, D1, and Fully-On (D0). Device and processor performance states (P0, P1, . . . Pn) are also discussed.

Chapter 3: ACPI Overview Gives an overview of the ACPI specification in terms of the functional areas covered by the specification: system power management, device power management, processor power management, Plug and Play, handling of system events, battery management, and thermal management.

1.9.2 Programming Models

Chapters 4 and 5 define the ACPI hardware and software programming models. This part of the specification is primarily for system designers, developers, and project managers.

All of the implementation-oriented, reference, and platform example Chapters of the specification that follow (all the rest of the Chapters of the specification) are based on the models defined in Chapters 4 and 5. These Chapters are the heart of the ACPI specification. There are extensive cross-references between the two Chapters.

Chapter 4: ACPI Hardware Specification Defines a set of hardware interfaces that meet the goals of this specification.

Chapter 5: ACPI Software Programming Model Defines a set of software interfaces that meet the goals of this specification.

1.9.3 Implementation Details

The third part of the specification defines the implementation details necessary to actually build components that work on an ACPI-compatible platform. This part of the specification is primarily for developers.

Chapter 6: Configuration Defines the reserved Plug and Play objects used to configure and assign resources to devices, and share resources and the reserved objects used to track device insertion and removal. Also defines the format of ACPI-compatible resource descriptors.

Chapter 7: Power and Performance Management Defines the reserved device power-management objects and the reserved-system power-management objects.

Chapter 8: Processor Configuration and Control Defines how the OS manages the processors' power consumption and other controls while the system is in the working state.

Chapter 9: ACPI-Specific Device Objects Lists the integrated devices that need support for some device-specific ACPI controls, along with the device-specific ACPI controls that can be provided. Most device objects are controlled through generic objects and control methods and have generic device IDs; this Chapter discusses the exceptions.

Chapter 10: Power Source Devices Defines the reserved battery device and AC adapter objects.

Chapter 11: Thermal Management Defines the reserved thermal management objects.

Chapter 12: ACPI Embedded Controller Interface Specification Defines the interfaces between an ACPI-compatible OS and an embedded controller.

Chapter 13: ACPI System Management Bus Interface Specification Defines the interfaces between an ACPI-compatible OS and a System Management Bus (SMBus) host controller.

Chapter 14: Platform Communications Channel Explains the generic mechanism for OSPM to communicate with an entity in the platform defines a new address space type.

Chapter 15: System Address Map Interfaces Explains the special INT 15 call for use in ISA/EISA/PCI bus-based systems. This call supplies the OS with a clean memory map indicating address ranges that are reserved and ranges that are available on the motherboard. UEFI-based memory address map reporting interfaces are also described.

Chapter 16: Waking and Sleeping Defines in detail the transitions between system working and sleeping states and their relationship to wake events. Refers to the reserved objects defined in Chapters 6, 7, and 8.

Chapter 17: Non-Uniform Memory Access (NUMA) Architecture Platforms Discusses in detail how ACPI define interfaces can be used to describe a NUMA architecture platform. Refers to the reserved objects defined in Chapters 5, 6, 8, and 9.

Chapter 18: ACPI Platform Error Interfaces Defines interfaces that enable OSPM to processes different types of hardware error events that are detected by platform-based error detection hardware.

1.9.4 Technical Reference

The fourth part of the specification contains reference material for developers.

Chapter 19: ACPI Source Language Reference Defines the syntax of all the ASL statements that can be used to write ACPI control methods, along with example syntax usage.

Chapter 20: ACPI Machine Language Specification Defines the grammar of the language of the ACPI virtual machine language. An ASL translator (compiler) outputs AML.

Chapter 21: ACPI Data Tables and Table Language Definition Describes a simple language (the Table Definition Language or TDL) that can be used to generate any ACPI data table.

Appendix A: Device class specifications Describes device-specific power management behavior on a per device-class basis.

Appendix B: Video Extensions Contains video device class-specific ACPI interfaces

1.9.5 Revision Numbers

Updates to the ACPI specification are considered either new revisions or errata as described below:

- A new revision is produced when there is substantive new content or changes that may modify existing behavior. New revisions are designated by a Major.Minor version number (e.g. 6.3). In cases where the changes are exceptionally minor, we may have a Major.Minor.Minor naming convention (e.g. 6.3.1).
- An errata is produced when proposed changes or fixes of the specification do not include any significant new material or modify existing behavior. Errata are designated by adding an upper-case letter at the end of the version number, such as 6.2A.

1.10 Related Documents

Power management and Plug and Play specifications for legacy hardware platforms are available from [Links to ACPI-Related Documents](#):

- Advanced Power Management (APM) BIOS Specification
- Plug and Play BIOS Specification

Intel Architecture specifications are available at <http://developer.intel.com> and <https://software.intel.com/en-us/articles/intel-sdm>.

Other UEFI Specifications are available at <https://uefi.org/specifications>:

- Unified Extensible Firmware Interface (UEFI) Specification
- Platform Integration (PI) Specification

Documentation and specifications for the Smart Battery System components and the SMBus are available at the following links:

- [Smart Battery System specifications](#)
- [SMBus specifications](#)

USB Power Delivery Specification (Revision 3.1, Version 1.3): see “Links to ACPI-Related Documents” (<http://uefi.org/acpi>) under the heading “Universal Serial Bus Power Management”

DEFINITION OF TERMS

This specification uses a particular set of terminology, defined in this section. This section has three parts:

General ACPI terms are defined and presented alphabetically.

The ACPI global system states (working, sleeping, soft off, and mechanical off) are defined. Global system states apply to the entire system, and are visible to the user.

The ACPI device power states are defined. Device power states are states of particular devices; as such, they are generally not visible to the user. For example, some devices may be in the off state even though the system as a whole is in the working state. Device states apply to any device on any bus.

2.1 General ACPI Terminology

Advanced Configuration and Power Interface (ACPI) As defined in this document, ACPI is a method for describing hardware interfaces in terms abstract enough to allow flexible and innovative hardware implementations and concrete enough to allow shrink-wrap OS code to use such hardware interfaces.

ACPI Hardware Computer hardware with the features necessary to support OSPM and with the interfaces to those features described using the Description Tables as specified by this document.

ACPI Namespace A hierarchical tree structure in OS-controlled memory that contains named objects. These objects may be data objects, control method objects, bus/device package objects, and so on. The OS dynamically changes the contents of the namespace at run-time by loading definition blocks from the ACPI Tables that reside in the ACPI system firmware. All the information in the ACPI Namespace comes from the Differentiated System Description Table (DSDT), which contains the Differentiated Definition Block, and one or more other definition blocks.

ACPI Machine Language (AML) Pseudo-code for a virtual machine supported by an ACPI-compatible OS and in which ACPI control methods and objects are written. The AML encoding definition is provided in section 19, “ACPI Machine Language (AML) Specification.”

Add-in Card A generic term used to refer to any device which can be inserted or removed from a platform through a connection bus, such as PCI. Add-in cards are typically inserted within a platform’s physical enclosure, rather than residing physically external to a platform. An add-in card will have its own devices and associated firmware, and may have its own Expansion ROM Firmware.

Advanced Programmable Interrupt Controller (APIC) An interrupt controller architecture commonly found on Intel Architecture-based 32-bit PC systems. The APIC architecture supports multiprocessor interrupt management (with symmetric interrupt distribution across all processors), multiple I/O subsystem support, 8259A compatibility, and inter-processor interrupt support. The architecture consists of local APICs commonly attached directly to processors and I/O APICs commonly in chip sets.

ACPI Source Language (ASL) The programming language equivalent for AML. ASL is compiled into AML images. The ASL statements are defined in section 18, “ACPI Source Language (ASL) Reference.”

Address Range Scrub (ARS) Process by which regions of memory can be scrubbed to look for memory locations that contain correctable or uncorrectable errors.

BIOS BIOS (Basic Input/Output System) is firmware that provides basic boot capabilities for a platform; it is used here to refer specifically to traditional x86 BIOS, and not as a general term for all firmware, or a replacement term for UEFI Core System BIOS. The ambiguity of this the term is what we are trying to remove. See also: *Legacy BIOS, System BIOS*.

Boot Firmware Generic term to describe any firmware on a platform used during the boot process. Use a more specific term, if possible.

Component Synonym for device. Please use the term “device” if possible.

Control Method A control method is a definition of how the OS can perform a simple hardware task. For example, the OS invokes control methods to read the temperature of a thermal zone. Control methods are written in an encoded language called AML that can be interpreted and executed by the ACPI-compatible OS. An ACPI-compatible system must provide a minimal set of control methods in the ACPI tables. The OS provides a set of well-defined control methods that ACPI table developers can reference in their control methods. OEMs can support different revisions of chip sets with one version of platform firmware by either including control methods in the platform firmware that test configurations and respond as needed or including a different set of control methods for each chip set revision.

Central Processing Unit (CPU) or Processor The part of a platform that executes the instructions that do the work. An ACPI-compatible OS can balance processor performance against power consumption and thermal states by manipulating the processor performance controls. The ACPI specification defines a working state, labeled G0 (S0), in which the processor executes instructions. Processor sleeping states, labeled C1 through C3, are also defined. In the sleeping states, the processor executes no instructions, thus reducing power consumption and, potentially, operating temperatures. The ACPI specification also defines processor performance states, where the processor (while in C0) executes instructions, but with lower performance and (potentially) lower power consumption and operating temperature. For more information, see [Section 8](#).

A definition block contains information about hardware implementation and configuration details in the form of data and control methods, encoded in AML. An OEM can provide one or more definition blocks in the ACPI Tables. One definition block must be provided: the Differentiated Definition Block, which describes the base system. Upon loading the Differentiated Definition Block, the OS inserts the contents of the Differentiated Definition Block into the ACPI Namespace. Other definition blocks, which the OS can dynamically insert and remove from the active ACPI Namespace, can contain references to the Differentiated Definition Block. For more information, see *Definition Blocks*.

Device A generic term used to refer to any computing, input/output or storage element, or any collection of computing, input/output or storage elements, on a platform. An example of a device is a CPU, APU, embedded controller (EC), BMC, Trusted Platform Module (TPM), graphics processing unit (GPU), network interface controller (NIC), hard disk drive (HDD), solid state drive (SSD), Read Only Memory (ROM), flash ROM, or any of the large number of other possible devices. If at all possible, use a more specific term.

Device Context The variable data held by the device; it is usually volatile. The device might forget this information when entering or leaving certain states (for more information, see *Device Power State Definitions*), in which case the OS software is responsible for saving and restoring the information. Device Context refers to small amounts of information held in device peripherals. See *System Context*.

Device Firmware Firmware that is only used by a specific device and cannot be used with any other device. This firmware is typically provided by the device manufacturer.

Differentiated System Description Table (DSDT) An OEM must supply a DSDT to an ACPI-compatible OS. The DSDT contains the Differentiated Definition Block, which supplies the implementation and configuration information about the base system. The OS always inserts the DSDT information into the ACPI Namespace at system boot time and never removes it.

Device Physical Address (DPA) A Device relative memory address.

Embedded Controller The general class of micro-controllers used to support OEM-specific supports embedded controllers in any platform design, as long as the micro-controller conforms to one of the models described in this section. The embedded controller performs complex low-level functions through a simple interface to the host microprocessor(s).

ACPI defines a standard hardware and software communications interface between an OS bus enumerator and an embedded controller. This allows any OS to provide a standard bus enumerator that can directly communicate with an embedded controller in the system, thus allowing other drivers within the system to communicate with and use the resources of system embedded controllers. This in turn enables the OEM to provide platform features that the OS and applications can use.

Embedded Controller Interface A standard hardware and software communications interface between an OS driver and an embedded controller. This allows any OS to provide a standard driver that can directly communicate with an embedded controller in the system, thus allowing other drivers within the system to communicate with and use the resources of system embedded controllers (for example, Smart Battery and AML code). This in turn enables the OEM to provide platform features that the OS and applications can use.

Expansion ROM Firmware Peripheral Component Interconnect (PCI) term for firmware executed on a host processor which is used by an add-in device during the boot process. This includes Option ROM Firmware and UEFI drivers. Expansion ROM Firmware may be embedded as part of the Host Processor Boot Firmware, or may be separate (e.g., from an add-in card). See also: *Option ROM Firmware*.

Firmware Generic term to describe any BIOS or firmware on a platform; it refers to the general class of things, not a specific type. Use a more specific term, if possible.

Firmware ACPI Control Structure (FACS) A structure in read/write memory that the platform runtime firmware uses for handshaking between the firmware and the OS. The FACS is passed to an ACPI-compatible OS via the Fixed ACPI Description Table (FADT). The FACS contains the system's hardware signature at last boot, the firmware waking vector, and the Global Lock.

Firmware Storage Device A memory device used to store firmware. This could include Read Only Memory (ROM), flash memory, eMMC, UFS drives, etc.

Fixed ACPI Description Table (FADT) A table that contains the ACPI Hardware Register Block implementation and configuration details that the OS needs to directly manage the ACPI Hardware Register Blocks, as well as the physical address of the DSDT, which contains other platform implementation and configuration details. An OEM must provide an FADT to an ACPI-compatible OS in the RSDT/XSDT. The OS always inserts the namespace information defined in the Differentiated Definition Block in the DSDT into the ACPI Namespace at system boot time, and the OS never removes it.

Fixed Features A set of features offered by an ACPI interface. The ACPI specification places restrictions on where and how the hardware programming model is generated. All fixed features, if used, are implemented as described in this specification so that OSPM can directly access the fixed feature registers.

Fixed Feature Events A set of events that occur at the ACPI interface when a paired set of status and event bits in the fixed feature registers are set at the same time. When a fixed feature event occurs, a system control interrupt (SCI) is raised. For ACPI fixed feature events, OSPM (or an ACPI-aware driver) acts as the event handler.

Fixed Feature Registers A set of hardware registers in fixed feature register space at specific address locations in system I/O address space. ACPI defines register blocks for fixed features (each register block gets a separate pointer from the FADT). For more information, see *ACPI Hardware Features*.

General-Purpose Event Registers The general-purpose event registers contain the event programming model for generic features. All general-purpose events generate SCIs.

Generic Feature A generic feature of a platform is value-added hardware implemented through control methods and general-purpose events.

Generic Interrupt Controller (GIC) An interrupt controller architecture for ARM processor-based systems.

Global System Status Global system states apply to the entire system, and are visible to the user. The various global system states are labeled G0 through G3 in the ACPI specification. For more information, see *Global System State Definitions*.

Host Processor A host processor is the primary processing unit in a platform, traditionally called a Central Processing Unit (CPU), now also sometimes referred to as an Application Processing Unit (APU), or a System on Chip (SoC). This is the processing unit on which the primary operating system (and/or hypervisor), as well as user applications run. This is the processor that is responsible for loading and executing the Host Processor Boot Firmware. This term and “Boot Processor” should be considered synonyms for this particular text clean-up effort (i.e., making them consistent should probably be part of a different ECR, if needed).

Host Processor Boot Firmware Generic term used to describe firmware loaded and executed by the Host Processor which provides basic boot capabilities for a platform. This class of firmware is a reference to Legacy BIOS and UEFI, which were sometimes referred to as System BIOS. Where the distinction between Legacy BIOS and UEFI is not important, the term Host Processor Boot Firmware will be used. Where the distinction is important, it will be referenced appropriately. Expansion ROM firmware may also be considered as part of the Host Processor Boot Firmware. Expansion ROM Firmware may be embedded as part of the Host Processor Boot Firmware, or may be separate from the Host Processor Boot Firmware (e.g., loaded from an add-in card).

Host Processor Runtime Firmware Host processor runtime firmware is any runtime firmware which executes on the host processor.

Ignored Bits Some unused bits in ACPI hardware registers are designated as “ignored” in the ACPI specification. Ignored bits are undefined and can return zero or one (in contrast to reserved bits, which always return zero). Software ignores ignored bits in ACPI hardware registers on reads and preserves ignored bits on writes.

Intel Architecture-Personal Computer (IA-PC) A general descriptive term for computers built with processors conforming to the architecture defined by the Intel processor family based on the Intel Architecture instruction set and having an industry-standard PC architecture.

I/O APIC An Input/Output Advanced Programmable Interrupt Controller routes interrupts from devices to the processor’s local APIC.

I/O SAPIC An Input/Output Streamlined Advanced Programmable Interrupt Controller routes interrupts from devices to the processor’s local APIC.

Label Storage Area A persistent storage area reserved for Label storage.

Legacy A computer state where power management policy decisions are made by the platform hardware/firmware shipped with the system. The legacy power management features found in today’s systems are used to support power management in a system that uses a legacy OS that does not support the OS-directed power management architecture.

Legacy BIOS One form of Host Processor Boot Firmware used on x86 platforms which uses a legacy x86 BIOS structure. This form of host processor boot firmware has been or is being replaced by UEFI. This term will likely be most useful in distinguishing and comparing older forms of firmware to newer forms (e.g., “it was done this way in legacy BIOS, but is now done another way in UEFI). See also: *BIOS, System BIOS*.

Legacy Hardware A computer system that has no ACPI or OSPM power management support.

Legacy OS An OS that is not aware of and does not direct the power management functions of the system. Included in this category are operating systems with APM 1.x support.

Local APIC A local Advanced Programmable Interrupt Controller receives interrupts from the I/O APIC.

Local SAPIC A local Streamlined Advanced Programmable Interrupt Controller receives interrupts from the I/O SAPIC.

Management Firmware Firmware used only by a Baseboard Management Controller (BMC) or other Out-of-Band (OOB) management controller.

Multiple APIC Description Table (MADT) The Multiple APIC Description Table (MADT) is used on systems supporting the APIC and SAPIC to describe the APIC implementation. Following the MADT is a list of APIC/SAPIC structures that declare the APIC/SAPIC features of the machine.

Namespace A namespace defines a contiguously-addressed range of Non-Volatile Memory, conceptually similar to a SCSI Logical Unit (LUN) or an NVM Express namespace. A namespace can be described by one or more Labels.

Non-Host Processor A non-host processor is a generic term used to describe any processing unit on a platform which is not a host processor (e.g. a microcontroller, co-processor, etc). For the purposes of this particular ECR, this should also be considered a synonym for “secondary processor”, those CPUs that might be on an SoC, for example, that are not the host (or “boot”) processor.

NVDIMM Non Volatile Dual In-line Memory Module.

Object The nodes of the ACPI Namespace are objects inserted in the tree by the OS using the information in the system definition tables. These objects can be data objects, package objects, control method objects, and so on. Package objects refer to other objects. Objects also have type, size, and relative name.

Object name Part of the ACPI Namespace. There is a set of rules for naming objects.

Operating System-directed Power Management (OSPM) A model of power (and system) management in which the OS plays a central role and uses global information to optimize system behavior for the task at hand.

Option ROM Firmware Legacy term for boot firmware typically executed on a host processor which is used by a device during the boot process. Option ROM firmware may be included with the host processor boot firmware or may be carried separately by a device (such as an add-in card). See also: Expansion ROM Firmware

Package An array of objects.

Peripheral A peripheral (also known as an external device) is a device which resides physically external to a platform and is connected to a platform, either wired or wirelessly. A peripheral is comprised of its own devices which may have their own firmware.

Persistent Memory (pmem) Byte-addressable memory that retains its contents across power loss.

Platform A platform consists of multiple devices assembled and working together to deliver a specific computing function, but does not include any other software other than the firmware as part of the devices in the platform. Examples of platforms include a notebook, a desktop, a server, a network switch, a blade, etc. - all without and independent of any operating system, user applications, or user data.

Platform Boot Firmware The collection of all boot firmware on a platform. This firmware is initially loaded by a platform (such as an SoC, a motherboard, or a complete system) at power-on to do basic initialization of the platform hardware and then hand control to a boot loader or OS. In some cases this will be x86 BIOS, or it may be UEFI Core System BIOS, or it could be something else entirely. Once control has been handed over to a boot loader or an OS, this firmware has no further role.

Platform Runtime Firmware The collection of all run-time firmware on a platform. This is firmware that can provide functions that can be invoked by an OS, but those functions are still concerned only with the platform hardware (e.g., PSCI on ARM). The assumption is that platform boot firmware has since been superseded by the OS since the OS is now up and running, but that there is still a need for an OS to access specific features of hardware that may only be possible via firmware.

Platform Firmware The collection of platform boot firmware and platform runtime firmware.

Power Button A user push button or other switch contact device that switches the system from the sleeping/soft off state to the working state, and signals the OS to transition to a sleeping/soft off state from the working state.

Power Management Mechanisms in software and hardware to minimize system power consumption, manage system thermal limits, and maximize system battery life. Power management involves trade-offs among system speed, noise, battery life, processing speed, and alternating current (AC) power consumption. Power management

is required for some system functions, such as appliance (for example, answering machine, furnace control) operations.

Power Resources Resources (for example, power planes and clock sources) that a device requires to operate in a given power state.

Power Sources The battery (including a UPS battery) and AC line powered adapters or power supplies that supply power to a platform.

Register Grouping Consists of two register blocks (it has two pointers to two different blocks of registers). The fixed-position bits within a register grouping can be split between the two register blocks. This allows the bits within a register grouping to be split between two chips.

Reserved Bits Some unused bits in ACPI hardware registers are designated as “Reserved” in the ACPI specification. For future extensibility, hardware-register reserved bits always return zero, and data writes to them have no side effects. OSPM implementations must write zeros to all reserved bits in enable and status registers and preserve bits in control registers.

Root System Description Pointer (RSDP) An ACPI-compatible system must provide an RSDP in the system’s low address space. This structure’s only purpose is to provide the physical address of the RSDT and XSDT.

Root System Description Table (RSDT) A table with the signature ‘RSDT,’ followed by an array of physical pointers to other system description tables. The OS locates that RSDT by following the pointer in the RSDP structure.

Runtime Firmware Generic term to describe any firmware on a platform used during runtime (i.e., after the boot process has completed). Use a more specific term, if possible.

Secondary System Description Table (SSDT) SSDTs are a continuation of the DSDT. Multiple SSDTs can be used as part of a platform description. After the DSDT is loaded into the ACPI Namespace, each secondary description table listed in the RSDT/XSDT with a unique OEM Table ID is loaded. This allows the OEM to provide the base support in one table, while adding smaller system options in other tables.

System Physical Address (SPA) The platform physical address assigned and programmed by the platform and utilized by the OS.

Sleep Button A user push button that switches the system from the sleeping/soft off state to the working state, and signals the OS to transition to a sleeping state from the working state.

Smart Battery Subsystem A battery subsystem that conforms to the following specifications: Smart Battery and either Smart Battery System Manager or Smart Battery Charger and Selector—and the additional ACPI requirements.

Smart Battery Table An ACPI table used on platforms that have a Smart Battery subsystem. This table indicates the energy-level trip points that the platform requires for placing the system into different sleeping states and suggested energy levels for warning the user to transition the platform into a sleeping state.

SMBus Interface A standard hardware and software communications interface between an OS bus driver and an SMBus controller.

Software Software is comprised of elements required to load the operating system and all user applications and user data subsequently handled by the operating system.

Streamlined Advanced Programmable Interrupt Controller (SAPIC) An advanced APIC commonly found on Intel Itanium™ Processor Family-based 64-bit systems.

System A system is the entirety of a computing entity, including all elements in a platform (hardware, firmware) and software (operating system, user applications, user data). A system can be thought of both as a logical construct (e.g. a software stack) or physical construct (e.g. a notebook, a desktop, a server, a network switch, etc).

System BIOS A term sometimes used in industry to refer to either Legacy BIOS, or to UEFI Core System BIOS, or both. Please use this term only when referring to Legacy BIOS. See also: BIOS, Legacy BIOS.

System Context The volatile data in the system that is not saved by a device driver.

System Control Interrupt (SCI) A system interrupt used by hardware to notify the OS of ACPI events. The SCI is an active, low, shareable, level interrupt.

System Management Bus (SMBus) A two-wire interface based upon the I²C protocol. The SMBus is a low-speed bus that provides positive addressing for devices, as well as bus arbitration.

System Management Interrupt (SMI) An OS-transparent interrupt generated by interrupt events on legacy systems. By contrast, on ACPI systems, interrupt events generate an OS-visible interrupt that is shareable (edge-style interrupts will not work). Hardware platforms that want to support both legacy operating systems and ACPI systems must support a way of re-mapping the interrupt events between SMIs and SCIs when switching between ACPI and legacy models.

Thermal States Thermal states represent different operating environment temperatures within thermal zones of a system. A system can have one or more thermal zones; each thermal zone is the volume of space around a particular temperature-sensing device. The transitions from one thermal state to another are marked by trip points, which are implemented to generate an SCI when the temperature in a thermal zone moves above or below the trip point temperature.

UEFI One form of Host Processor Boot Firmware which uses a Unified Extensible Firmware Interface (UEFI) structure (as defined by the UEFI Forum). This is the current host processor boot firmware structure being adopted as a standard in the industry. This term should be used when referring specifically to UEFI code on a platform.

UEFI Drivers Standalone binary executables in PECOFF format which are loaded by UEFI during the boot process to handle specific pieces of hardware.

eXtended Root System Description Table (XSDT) The XSDT provides identical functionality to the RSDT but accommodates physical addresses of DESCRIPTION HEADERS that are larger than 32 bits. Notice that both the XSDT and the RSDT can be pointed to by the RSDP structure.

2.2 Global System State Definitions

Global system states (Gx states) apply to the entire system and are visible to the user.

Global system states are defined by six principal criteria:

1. Does application software run?
2. What is the latency from external events to application response?
3. What is the power consumption?
4. Is an OS reboot required to return to a working state?
5. Is it safe to disassemble the computer?
6. Can the state be entered and exited electronically?

Following is a list of the system states:

G3 Mechanical Off A computer state that is entered and left by a mechanical means (for example, turning off the system's power through the movement of a large red switch). It is implied by the entry of this off state through a mechanical means that no electrical current is running through the circuitry and that it can be worked on without damaging the hardware or endangering service personnel. The OS must be restarted to return to the Working state. No hardware context is retained. Except for the real-time clock, power consumption is zero.

G2/S5 Soft Off A computer state where the computer consumes a minimal amount of power. No user mode or system mode code is run. This state requires a large latency in order to return to the Working state. The system's context will not be preserved by the hardware. The system must be restarted to return to the Working state. It is not safe to disassemble the machine in this state.

G1 Sleeping A computer state where the computer consumes a small amount of power, user mode threads are not being executed, and the system “appears” to be off (from an end user’s perspective, the display is off, and so on). Latency for returning to the Working state varies on the wake environment selected prior to entry of this state (for example, whether the system should answer phone calls). Work can be resumed without rebooting the OS because large elements of system context are saved by the hardware and the rest by system software. It is not safe to disassemble the machine in this state.

G0 Working A computer state where the system dispatches user mode (application) threads and they execute. In this state, peripheral devices (peripherals) are having their power state changed dynamically. The user can select, through some UI, various performance/power characteristics of the system to have the software optimize for performance or battery life. The system responds to external events in real time. It is not safe to disassemble the machine in this state.

S4 Non-Volatile Sleep A special global system state that allows system context to be saved and restored (relatively slowly) when power is lost to the motherboard. If the system has been commanded to enter S4, the OS will write all system context to a file on non-volatile storage media and leave appropriate context markers. The machine will then enter the S4 state. When the system leaves the Soft Off or Mechanical Off state, transitioning to Working (G0) and restarting the OS, a restore from a NVS file can occur. This will only happen if a valid non-volatile sleep data set is found, certain aspects of the configuration of the machine have not changed, and the user has not manually aborted the restore. If all these conditions are met, as part of the OS restarting, it will reload the system context and activate it. The net effect for the user is what looks like a resume from a Sleeping (G1) state (albeit slower). The aspects of the machine configuration that must not change include, but are not limited to, disk layout and memory size. It might be possible for the user to swap a PC Card or a Device Bay device, however.

Notice that for the machine to transition directly from the Soft Off or Sleeping states to S4, the system context must be written to non-volatile storage by the hardware; entering the Working state first so that the OS or platform runtime firmware can save the system context takes too long from the user’s point of view. The transition from Mechanical Off to S4 is likely to be done when the user is not there to see it.

Because the S4 state relies only on non-volatile storage, a machine can save its system context for an arbitrary period of time (on the order of many years).

Table 2.1: Summary of Global Power States

Global state	system	Software runs	Latency	Power consumption	OS restart required	Safe to dis-assemble computer	Exit state electronically
G0 Working		Yes	0	Large	No	No	Yes
G1 Sleeping		No	>0, varies with sleep state	Smaller	No	No	Yes
G2/S5 Soft Off		No	Long	Very near 0	Yes	No	Yes
G3 Mechanical Off		No	Long	RTC battery	Yes	Yes	No

Notice that the entries for G2/S5 and G3 in the Latency column of the above table are “Long.” This implies that a platform designed to give the user the appearance of “instant-on,” similar to a home appliance device, will use the G0 and G1 states almost exclusively (the G3 state may be used for moving the machine or repairing it).

2.3 Device Power State Definitions

Device power states are states of particular devices; as such, they are generally not visible to the user. For example, some devices may be in the Off state even though the system as a whole is in the Working state.

Device states apply to any device on any bus. They are generally defined in terms of four principal criteria:

- Power consumption—How much power the device uses.
- Device context—How much of the context of the device is retained by the hardware. The OS is responsible for restoring any lost device context (this may be done by resetting the device).
- Device driver—What the device driver must do to restore the device to full on.
- Restore time—How long it takes to restore the device to full on.

The device power states are defined below, although very generically. Many devices do not have all four power states defined. Devices may be capable of several different low-power modes, but if there is no user-perceptible difference between the modes, only the lowest power mode will be used. The Device Class Power Management Specifications, included in Appendix A of this specification, describe which of these power states are defined for a given type (class) of device and define the specific details of each power state for that device class. For a list of the available Device Class Power Management Specifications, see [Appendix A: Device Class Specifications](#).

D3 (Off) Power has been fully removed from the device. Also referred to as D3cold in this and other specs. All device context is lost when this state is entered, so the OS software will reinitialize the device when powering it back on. Since all device context and power are lost, devices in this state do not decode their address lines, and cannot be enumerated by software. Devices in this state have the longest restore times.

D3hot The meaning of the D3hot State is defined by each device class. In general, D3hot is expected to save as much power as possible without affecting PNP Enumeration. Devices in D3hot must have enough power to remain enumerable by software. For example, PCI Configuration space access and contents must operate as in shallower power states. Similarly, ACPI identification and configuration objects must operate as in shallower power states. Otherwise, no device functionality is supported, and Driver software is required to restore any lost context, or reinitialize the device, during its transition back to D0.

Devices in this state can have long restore times. All classes of devices define this state.

Note: For devices that support both D3hot and D3 exposed to OSPM via `_PR3`, device software/drivers must always assume OSPM will target D3 and must assume all device context will be lost and the device will no longer be enumerable.

D2 The meaning of the D2 Device State is defined by each device class. Many device classes may not define D2. In general, D2 is expected to save more power and preserve less device context than D1 or D0. Buses in D2 may cause the device to lose some context (for example, by reducing power on the bus, thus forcing the device to turn off some of its functions).

D1 The meaning of the D1 Device State is defined by each device class. Many device classes may not define D1. In general, D1 is expected to save less power and preserve more device context than D2.

D0 (Fully-On) This state is assumed to be the highest level of power consumption. The device is completely active and responsive, and is expected to remember all relevant context continuously.

Transitions amongst these power states are restricted for simplicity. Power-down transitions (from higher-power, or shallower, to lower-power, or deeper) are allowed between any two states. However, power-up transitions (from deeper to shallower) are required to go through D0; i.e. D_y to $D_x < y$ is illegal for all $x \neq 0$.

Table 2.2: Summary of Device Power States

Device State	Power Consumption	Device Context Retained	Driver Restoration
D0 - Fully-On	As needed for operation	All	None
D1	D0>D1>D2> D3hot>D3	>D2	<D2
D2	D0>D1>D2> D3hot>D3	<D1	>D1
D3hot	D0>D1>D2>D3hot>D3	Optional	None <->Full initialization and load
D3 - Off	0	None	Full initialization and load

Note: Devices often have different power modes within a given state. Devices can use these modes as long as they can automatically transparently switch between these modes from the software, without violating the rules for the current Dx state the device is in. Low-power modes that adversely affect performance (in other words, low speed modes) or that are not transparent to software cannot be done automatically in hardware; the device driver must issue commands to use these modes.

2.3.1 Device Performance States

Device performance states (Px states) are power consumption and capability states within the active (D0) device power state. Performance states allow OSPM to make tradeoffs between performance and energy conservation. Device performance states have the greatest impact when the implementation is such that the states invoke different device efficiency levels as opposed to a linear scaling of performance and energy consumption. Since performance state transitions occur in the active device states, care must be taken to ensure that performance state transitions do not adversely impact the system.

Device performance states, when necessary, are defined on a per device class basis (See *Appendix A: Device Class Specifications* for more information).

2.4 Sleeping and Soft-off State Definitions

S1-S4 are types of sleeping states within the global system state, G1, while S5 is a soft-off state associated with the G2 system state. The Sx states are briefly defined below.

For a detailed definition of the system behavior within each Sx state, see *_Sx (System States)*. For a detailed definition of the transitions between each of the Sx states, see *Sleeping States*.

S1 Sleeping State The S1 sleeping state is a low wake latency sleeping state. In this state, no system context is lost (CPU or chip set) and hardware maintains all system context.

S2 Sleeping State The S2 sleeping state is a low wake latency sleeping state. This state is similar to the S1 sleeping state except that the CPU and system cache context is lost (the OS is responsible for maintaining the caches and CPU context). Control starts from the processor's reset vector after the wake event.

S3 Sleeping State The S3 sleeping state is a low wake latency sleeping state where all system context is lost except system memory. CPU, cache, and chip set context are lost in this state. Hardware maintains memory context and restores some CPU and L2 configuration context. Control starts from the processor's reset vector after the wake event.

S4 Sleeping State The S4 sleeping state is the lowest power, longest wake latency sleeping state supported by ACPI. In order to reduce power to a minimum, it is assumed that the hardware platform has powered off all devices. Platform context is maintained.

S5 Soft Off State The S5 state is similar to the S4 state except that the OS does not save any context. The system is in the “soft” off state and requires a complete boot when it wakes. Software uses a different state value to distinguish between the S5 state and the S4 state to allow for initial boot operations within the platform boot firmware to distinguish whether the boot is going to wake from a saved memory image.

2.5 Processor Power State Definitions

Processor power states (Cx states) are processor power consumption and thermal management states within the global working state, G0. The Cx states possess specific entry and exit semantics and are briefly defined below. For a more detailed definition of each Cx state, see *Processor Power States*.

C0 Processor Power State While the processor is in this state, it executes instructions.

C1 Processor Power State This processor power state has the lowest latency. The hardware latency in this state must be low enough that the operating software does not consider the latency aspect of the state when deciding whether to use it. Aside from putting the processor in a non-executing power state, this state has no other software-visible effects.

C2 Processor Power State The C2 state offers improved power savings over the C1 state. The worst-case hardware latency for this state is provided via the ACPI system firmware and the operating software can use this information to determine when the C1 state should be used instead of the C2 state. Aside from putting the processor in a non-executing power state, this state has no other software-visible effects.

C3 Processor Power State The C3 state offers improved power savings over the C1 and C2 states. The worst-case hardware latency for this state is provided via the ACPI system firmware and the operating software can use this information to determine when the C2 state should be used instead of the C3 state. While in the C3 state, the processor’s caches maintain state but ignore any snoops. The operating software is responsible for ensuring that the caches maintain coherency.

2.6 Device and Processor Performance State Definitions

Device and Processor performance states (Px states) are power consumption and capability states within the active/executing states, C0 for processors and D0 for devices. The Px states are briefly defined below. For a more detailed definition of each Px state from a processor perspective, see *Processor Performance Control*. For a more detailed definition of each Px state from a device perspective see *Device and Processor Performance States*, and *Appendix A: Device Class Specifications*.

P0 Performance State While a device or processor is in this state, it uses its maximum performance capability and may consume maximum power.

P1 Performance State In this performance power state, the performance capability of a device or processor is limited below its maximum and consumes less than maximum power.

Pn Performance State In this performance state, the performance capability of a device or processor is at its minimum level and consumes minimal power while remaining in an active state. State n is a maximum number and is processor or device dependent. Processors and devices may define support for an arbitrary number of performance states not to exceed 255.

ACPI CONCEPTS

Platforms compliant with the ACPI specification provide OSPM with direct and exclusive control over the power management and motherboard device configuration functions of a computer. During OS initialization, OSPM takes over these functions from legacy implementations such as the APM BIOS, SMM-based firmware, legacy applications, and the PNPBIOS. Having done this, OSPM is responsible for handling motherboard device configuration events as well as for controlling the power, performance, and thermal status of the system based on user preference, application requests and OS imposed Quality of Service (QOS) / usability goals. ACPI provides low-level interfaces that allow OSPM to perform these functions. The functional areas covered by the ACPI specification are:

System power management ACPI defines mechanisms for putting the computer as a whole in and out of system sleeping states. It also provides a general mechanism for any device to wake the computer.

Device power management ACPI tables describe motherboard devices, their power states, the power planes the devices are connected to, and controls for putting devices into different power states. This enables the OS to put devices into low-power states based on application usage.

Processor power management While the OS is idle but not sleeping, it will use commands described by ACPI to put processors in low-power states.

Device and processor performance management While the system is active, OSPM will transition devices and processors into different performance states, defined by ACPI, to achieve a desirable balance between performance and energy conservation goals as well as other environmental requirements (for example, visibility and acoustics).

Configuration / Plug and Play ACPI specifies information used to enumerate and configure motherboard devices. This information is arranged hierarchically so when events such as docking and undocking take place, the OS has precise, a priori knowledge of which devices are affected by the event.

System Events ACPI provides a general event mechanism that can be used for system events such as thermal events, power management events, docking, device insertion and removal, and so on. This mechanism is very flexible in that it does not define specifically how events are routed to the core logic chip set.

Battery management Battery management policy moves from the APM BIOS to the ACPI OS. An ACPI-compatible battery device needs either a Smart Battery subsystem interface, which is controlled by the OS directly through the embedded controller interface, or a Control Method Battery interface. A Control Method Battery interface is completely defined by AML control methods, allowing an OEM to choose any type of the battery and any kind of communication interface supported by ACPI. The battery must comply with the requirements of its interface, as described either herein or in other applicable standards. The OS may choose to alter the behavior of the battery, for example, by adjusting the Low Battery or Battery Warning trip point. When there are multiple batteries present, the battery subsystem is not required to perform any synthesis of a “composite battery” from the data of the separate batteries. In cases where the battery subsystem does not synthesize a “composite battery” from the separate battery’s data, the OS must provide that synthesis.

Thermal management Since the OS controls the power and performance states of devices and processors, ACPI also addresses system thermal management. It provides a simple, scalable model that allows OEMs to define thermal zones, thermal indicators, and methods for cooling thermal zones.

SMBus Controller ACPI defines a standard hardware and software communications interface between an OS bus driver and an SMBus Controller. This allows any OS to provide a standard bus driver that can directly communicate with SMBus devices in the system. This in turn enables the OEM to provide platform features that the OS and applications can use.

OSPM's mission is to optimally configure the platform and to optimally manage the system's power, performance, and thermal status given the user's preferences and while supporting OS imposed Quality of Service (QOS) / usability goals. To achieve these goals, ACPI requires that once an ACPI compliant platform is in ACPI mode, the platform's hardware, firmware, or other non-OS software must not manipulate the platform's configuration, power, performance, and thermal control interfaces independently of OSPM. OSPM alone is responsible for coordinating the configuration, power management, performance management, and thermal control policy of the system. Manipulation of these interfaces independently of OSPM undermines the purpose of OSPM/ACPI and may adversely impact the system's configuration, power, performance, and thermal policy goals. There are two exceptions to this requirement. The first is in the case of the possibility of damage to a system from an excessive thermal conditions where an ACPI compatible OS is present and OSPM latency is insufficient to remedy an adverse thermal condition. In this case, the platform may exercise a failsafe thermal control mechanism that reduces the performance of a system component to avoid damage. If this occurs, the platform must notify OSPM of the performance reduction if the reduction is of significant duration (in other words, if the duration of reduced performance could adversely impact OSPM's power or performance control policy - operating system vendors can provide guidance in this area). The second exception is the case where the platform contains Active cooling devices but does not contain Passive cooling temperature trip points or controls,. In this case, a hardware based Active cooling mechanism may be implemented without impacting OSPM's goals. Any platform that requires both active and passive cooling must allow OSPM to manage the platform thermals via ACPI defined active and passive cooling interfaces.

3.1 System Power Management

Under OSPM, the OS directs all system and device power state transitions. Employing user preferences and knowledge of how devices are being used by applications, the OS puts devices in and out of low-power states. Devices that are not being used can be turned off. Similarly, the OS uses information from applications and user settings to put the system as a whole into a low- power state. The OS uses ACPI to control power state transitions in hardware.

3.2 Power States

From a user-visible level, the system can be thought of as being in one of the states in the following diagram:

See [Section 2.2](#) for detailed definitions of these states.

In general use, computers alternate between the Working and Sleeping states. In the Working state, the computer is used to do work. User-mode application threads are dispatched and running. Individual devices can be in low-power (Dx) states and processors can be in low-power (Cx) states if they are not being used. Any device the system turns off because it is not actively in use can be turned on with short latency. (What "short" means depends on the device. An LCD display needs to come on in sub-second times, while it is generally acceptable to wait a few seconds for a printer to wake.)

The net effect of this is that the entire machine is functional in the Working state. Various Working sub-states differ in speed of computation, power used, heat produced, and noise produced. Tuning within the Working state is largely about trade-offs among speed, power, heat, and noise.

When the computer is idle or the user has pressed the power button, the OS will put the computer into one of the sleeping (Sx) states. No user-visible computation occurs in a sleeping state. The sleeping sub-states differ in what events can arouse the system to a Working state, and how long this takes. When the machine must awaken to all possible events or do so very quickly, it can enter only the sub-states that achieve a partial reduction of system power consumption. However, if the only event of interest is a user pushing on a switch and a latency of minutes is allowed,

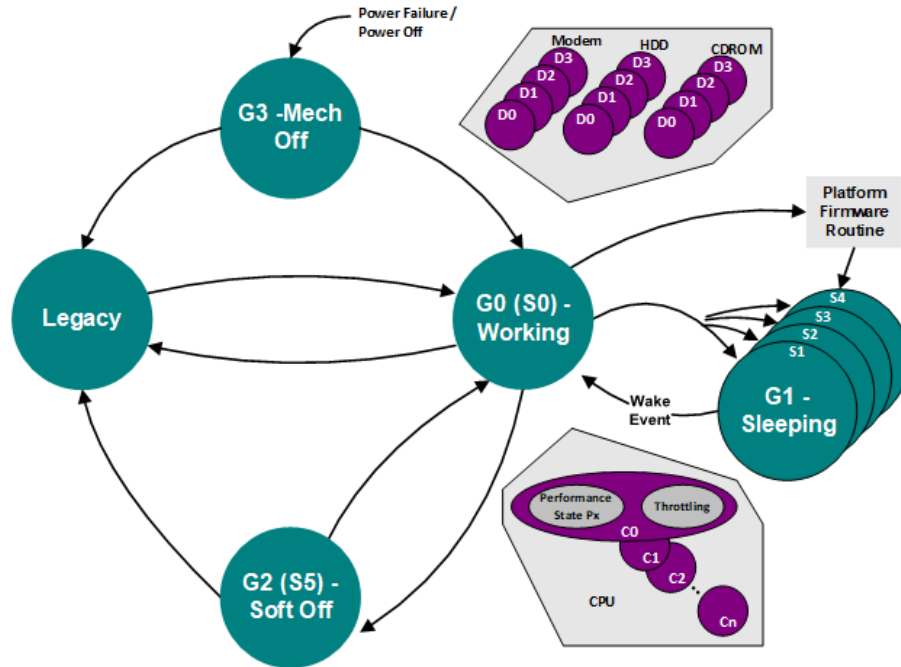

Fig. 3.1: Global System Power States and Transitions

the OS could save all system context into an NVS file and transition the hardware into the S4 sleeping state. In this state, the machine draws almost zero power and retains system context for an arbitrary period of time (years or decades if needed).

The other states are used less often. Computers that support legacy BIOS power management interfaces boot in the Legacy state and transition to the Working state when an ACPI OS loads. A system without legacy support (for example, a RISC system) transitions directly from the Mechanical Off state to the Working state. Users typically put computers into the Mechanical Off state by flipping the computer’s mechanical switch or by unplugging the computer.

3.2.1 Power Button

In legacy systems, the power button typically either forces the machine into Soft Off or Mechanical Off or, on a laptop, forces it to some sleeping state. No allowance is made for user policy (such as the user wants the machine to “come on” in less than 1 second with all context as it was when the user turned the machine “off”), system alert functions (such as the system being used as an answering machine or fax machine), or application function (such as saving a user file).

In an OSPM system, there are two switches. One is to transition the system to the Mechanical Off state. A mechanism to stop current flow is required for legal reasons in some jurisdictions (for example, in some European countries). The other is the “main” power button. This is in some obvious place (for example, beside the keyboard on a laptop). Unlike legacy on/off buttons, all it does is send a request to the system. What the system does with this request depends on policy issues derived from user preferences, user function requests, and application data.

3.2.2 Platform Power Management Characteristics

3.2.2.1 Mobile PC

Mobile PCs will continue to have aggressive power management functionality. Going to OSPM/ACPI will allow enhanced power savings techniques and more refined user policies.

Aspects of mobile PC power management in the ACPI specification are thermal management (see Section 3.10).

3.2.2.2 Desktop PCs

Power-managed desktops will be of two types, though the first type will migrate to the second over time.

Ordinary “Green PC” Here, new appliance functions are not the issue. The machine is really only used for productivity computations. At least initially, such machines can get by with very minimal function. In particular, they need the normal ACPI timers and controls, but don’t need to support elaborate sleeping states, and so on. They, however, do need to allow the OS to put as many of their devices/resources as possible into device standby and device off states, as independently as possible (to allow for maximum compute speed with minimum power wasted on unused devices). Such PCs will also need to support wake from the sleeping state by means of a timer, because this allows administrators to force them to turn on just before people are to show up for work.

Home PC Computers are moving into home environments where they are used in entertainment centers and to perform tasks like answering the phone. A home PC needs all of the functionality of the ordinary green PC. In fact, it has all of the ACPI power functionality of a laptop except for docking and lid events (and need not have any legacy power management). Note that there is also a thermal management aspect to a home PC, as a home PC user wants the system to run as quietly as possible, often in a thermally constrained environment.

3.2.2.3 Multiprocessor and Server PCs

Perhaps surprisingly, server machines often get the largest absolute power savings. Why? Because they have the largest hardware configurations and because it’s not practical for somebody to hit the off switch when they leave at night.

Day Mode In day mode, servers are power-managed much like a corporate ordinary green PC, staying in the Working state all the time, but putting unused devices into low-power states whenever possible. Because servers can be very large and have, for example, many disk spindles, power management can result in large savings. OSPM allows careful tuning of when to do this, thus making it workable.

Night Mode In night mode, servers look like home PCs. They sleep as deeply as they can and are still able to wake and answer service requests coming in over the network, phone links, and so on, within specified latencies. So, for example, a print server might go into deep sleep until it receives a print job at 3 A.M., at which point it wakes in perhaps less than 30 seconds, prints the job, and then goes back to sleep. If the print request comes over the LAN, then this scenario depends on an intelligent LAN adapter that can wake the system in response to an interesting received packet.

3.3 Device Power Management

This section describes ACPI-compatible device power management. The ACPI device power states are introduced, the controls and information an ACPI-compatible OS needs to perform device power management are discussed, the wake operation devices use to wake the computer from a sleeping state is described, and an example of ACPI-compatible device management using a modem is given

3.3.1 Device Power Management Model

ACPI Device Power Management is based on an integrated model consisting of:

Distributed device power state policy For each hardware device on the system, there is a Power Policy Owner in the Operating System that is responsible for continuously determining the best power state for the device. The best device power state is the one that, at any point in time, minimizes the consumption of power by the device consistent with the usage requirements of the device by the system and its user. Policy is typically defined for a class of devices, and incorporates application activity, user scenarios and other operating state as necessary. It is applied to all devices of a given class.

Layered device power state control Once power state decisions are made for a device, they must be carried-out by device drivers. The model partitions the control functionality between the device, bus and platform layers. Device drivers at each layer perform control using mechanisms available at that level, coordinated by OSPM. In general, the ordering proceeds from Device/Class level, to Bus level, to Platform level when a device is powering down, and the inverse when powering-up.

For instance, a device-level driver has access, via the device programming interface, to settings and control registers that invoke specific, sometimes proprietary, power control features in the device. The device driver uses these controls as appropriate for the target ACPI-defined power state determined by the policy owner. Similarly, classes of devices may have standardized power features, invoked in standardized ways that Class Drivers might use when entering a target power state.

At the bus level, power management standards come into play to provide bus-specific controls that work for every device connected to the bus, regardless of device class. PCI, for instance, defines fields in the device Configuration Space for setting the device's power state (D0-D3). Bus-level drivers utilize these standards to perform control in addition to that applied by the device-specific or device class driver. Bus-specific mechanisms also enable additional power savings in the system by enabling the bus infrastructure hardware itself to enter lower power states, as defined in the bus standard.

Finally, for platform-level power state control, ACPI defines mechanisms (`_PRx`, `_PSx`, `_ON`, `_OFF`) for putting a device into a given power state. The Operating System's Power Management software (OSPM) utilizes these mechanisms to execute the lowest-level, platform-specific control for a given device (such as turning power rails and clocks off and on, resetting hardware, etc.).

Operating System coordination Finally, ACPI defines information and behavior requirements that enable OSPM to inform the Power Policy Owner about supported state and wake-up capabilities, and to coordinate the actions of the various levels of device drivers in controlling power. OSPM, in this role, is responsible for ensuring that device power management is coordinated with System Power Management such as entering sleep states (S1-S4) or Low-power Idle states (LPI). Integrated with device power state policy and control, wake-up policy and control are also coordinated by OSPM. Power Policy Owners, which decide when the device might be needed to wake the system, ensure that only device power states that the device can wake from are selected when the platform enters a Sleep or LPI state. Enabling of wake-up hardware is also performed at the device, bus and platform levels and coordinated by OSPM. OSPM ensures further that the Sleep or LPI state selected for the system is compatible with the device state and wake-up capabilities of all the devices currently enabled for wake.

3.3.2 Power Management Standards

To manage power of all the devices in the system, the OS needs standard methods for sending commands to a device. These standards define the operations used to manage power of devices on a particular I/O interconnect and the power states that devices can be put into. Defining these standards for each I/O interconnect creates a baseline level of power management support the OS can utilize. Independent Hardware Vendors (IHVs) do not have to spend extra time writing software to manage power of their hardware, because simply adhering to the standard gains them direct OS support. For OS vendors, the I/O interconnect standards allow the power management code to be centralized in the driver for each I/O interconnect. Finally, I/O interconnect-driven power management allows the OS to track the states of all devices on a given I/O interconnect. When all the devices are in a given state (or example, D3 - off), the OS can put the entire I/O interconnect into the power supply mode appropriate for that state (for example, D3 - off).

I/O interconnect-level power management specifications are written for a number of buses including:

- PCI
- PCI Express
- CardBus
- USB
- IEEE 1394

3.3.3 Device Power States

To unify nomenclature and provide consistent behavior across devices, standard definitions are used for the power states of devices. Generally, these states are defined in terms of the following criteria:

- Power consumption—How much power the device uses.
- Device context—How much of the context of the device is retained by the hardware.
- Device driver—What the device driver must do to restore the device to fully on.
- Restore latency—How long it takes to restore the device to fully on.

More specifically, power management specifications for each class of device (for example, modem, network adapter, hard disk, and so on) more precisely define the power states and power policy for the class. See *Device Power States* for a detailed description of the general device power states (D0-D3).

3.3.4 Device Power State Definitions

The device power state definitions are device-independent, but classes of devices on a bus must support some consistent set of power-related characteristics. For example, when the bus-specific mechanism to set the device power state to a given level is invoked, the actions a device might take and the specific sorts of behaviors the OS can assume while the device is in that state will vary from device type to device type. For a fully integrated device power management system, these class-specific power characteristics must also be standardized:

Device Power State Characteristics Each class of device has a standard definition of target power consumption levels, state-change latencies, and context loss.

Minimum Device Power Capabilities Each class of device has a minimum standard set of power capabilities.

Device Functional Characteristics Each class of device has a standard definition of what subset of device functionality or features is available in each power state (for example, the net card can receive, but cannot transmit; the sound card is fully functional except that the power amps are off, and so on).

Device Wakeup Characteristics Each class of device has a standard definition of its wake policy.

The Device Class power management specifications define these power state characteristics for each class of device. See [Appendix A: Device Class Specifications](#).

3.4 Controlling Device Power

ACPI interfaces provide the control methods and information needed to manage device power. OSPM leverages these interfaces to perform tasks like determining the capabilities of a device, executing methods to set a device's power state or get its status, and enabling a device to wake the machine.

- Other buses enumerate some devices on the main board. For example, PCI devices are reported through the standard PCI enumeration mechanisms. Power management of these devices is handled through their own bus specification (in this case, PCI). All other devices on the main board are handled through ACPI. Specifically, the ACPI table lists legacy devices that cannot be reported through their own bus specification, the root of each bus in the system, and devices that have additional power management or configuration options not covered by their own bus specification.

For more detailed information see [Section 7](#)

3.4.1 Getting Device Power Capabilities

As the OS enumerates devices in the system, it gets information about the power management features that the device supports. The Differentiated Definition Block given to the OS by the platform boot firmware describes every device handled by ACPI. This description contains the following information:

- A description of what power resources (power planes and clock sources) the device needs in each power state that the device supports. For example, a device might need a high power bus and a clock in the D0 state but only a low-power bus and no clock in the D2 state.
- A description of what power resources a device needs in order to wake the machine (or none to indicate that the device does not support wake). The OS can use this information to infer what device and system power states from which the device can support wake.
- The optional control method the OS can use to set the power state of the device and to get and set resources.

In addition to describing the devices handled by ACPI, the table lists the power planes and clock sources themselves and the control methods for turning them on and off. For detailed information, see [Section 7](#).

3.4.2 Setting Device Power States

OSPM uses the Set Power State operation to put a device into one of the four power states.

When a device is put in a lower power state, it configures itself to draw as little power from the bus as possible. The OS tracks the state of all devices on the bus, and will put the bus in the best power state based on the current device requirements on that bus. For example, if all devices on a bus are in the D3 state, the OS will send a command to the bus control chip set to remove power from the bus (thus putting the bus in the D3 state). If a particular bus supports a low-power supply state, the OS puts the bus in that state if all devices are in the D1 or D2 state. Whatever power state a device is in, the OS must be able to issue a Set Power State command to resume the device.

- The device does not need to have power to do this. The OS must turn on power to the device before it can send commands to the device.

OSPM also uses the Set Power State operation to enable power management features such as wake (described in [Power and Performance Management](#)).

For power-down operations (transitions from Dx to some deeper Dy), OSPM first evaluates the appropriate control method for the target state (`_PSx`), then turns-off any unused power resources. Notice that this might not mean that

power is actually removed from the device. If other active devices are sharing a power resource, the power resource will remain on. In the power-up case (transitions from some Dx back to the shallower D0), the power resources required for D0 are first turned on, and then the control method (_PS0) is evaluated.

3.4.3 Getting Device Power Status

OSPM uses the Get Power Status operation to determine the current power configuration (states and features), as well as the status of any batteries supported by the device. The device can signal an SCI to inform the OS of changes in power status. For example, a device can trigger an interrupt to inform the OS that the battery has reached low power level.

Devices use the ACPI event model to signal power status changes (for example, battery status changes) to OSPM. The platform signals events to the OS via an interrupt, either SCI, or GPIO. An interrupt status bit is set to indicate the event to the OS. The OS runs the control method associated with the event. This control method signals to the OS which device has changed.

ACPI supports two types of batteries: batteries that report only basic battery status information and batteries that support the Smart Battery System Implementers Forum “Smart Battery Specification”. For batteries that report only basic battery status information (such as total capacity and remaining capacity), the OS uses control methods from the battery’s description table to read this information. To read status information for Smart Batteries, the OS can use a standard Smart Battery driver that directly interfaces to Smart Batteries through the appropriate bus enumerator.

3.4.4 Waking the System

The wake operation enables devices to wake the system from a sleeping or low-power idle state. This operation must not depend on the CPU because the CPU will not be executing instructions.

The OS ensures any bridges between the device and the core logic are in the lowest power state in which they can still forward the wake signal. When a device with wake enabled decides to wake the system, it sends the defined signal on its bus. Bus bridges must forward this signal to upstream bridges using the appropriate signal for that bus. Thus, the signal eventually reaches the core chip set (for example, an ACPI chip set), which in turn wakes the system.

Before putting the system in a sleeping power state, the OS determines which devices are needed to wake the system based on application requests, and then enables wake on those devices in a device and bus specific manner.

The OS enables the wake feature on devices by setting that device’s SCI Enable bit or unmasking its wake interrupt. The location of this control is listed in the device’s entry in the description table. Only devices that have their wake feature enabled can wake the system. The OS keeps track of the power states that the wake devices support, and keeps the system in a power state in which the wake can still wake the system (based on capabilities reported in the description table).

When the system is in a Sleeping or low-power idle state and a wake device decides to wake the system, it signals to the core logic. The status bit corresponding to the device waking the system is set, and the core logic resumes the system. After the OS is running again, it determines the device responsible for the wake event by either running a control method (for wake events) or processing the device’s ISR (for wake interrupts).

- Besides using ACPI mechanism to enable a particular device to wake the system, an ACPI platform must also be able to record and report the wake source to OSPM. When a system is woken from certain states (such as the S4 state), it may start out in non-ACPI mode. In this case, the SCI status bit may be cleared when ACPI mode is re-entered. However the platform must still attempt to record the wake source for retrieval by OSPM at a later point.
- Although the above description explains how a device can wake the system, note that a device can also be put into a low power state during the S0 system state, and that this device may generate a wake signal in the S0 state as the following example illustrates.

3.4.5 Example: Modem Device Power Management

To illustrate how these power management methods function in ACPI, consider an integrated modem. (This example is greatly simplified for the purposes of this discussion.) The power states of a modem are defined as follows (from the Modem Device Class Power Management Specification):

D0 Modem controller on Phone interface on Speaker on Can be on hook or off hook Can be waiting for answer

D1 Modem controller in low-power mode (context retained by device) Phone interface powered by phone line or in low-power mode Speaker off Must be on hook

D2 Same as D3

D3 Modem controller off (context lost) Phone interface powered by phone line or off Speaker off On hook

The power policy for the modem is defined as follows:

D3 D0 COM port opened

D0, D1 D3 COM port closed

D0 D1 Modem put in answer mode

D1 D0 Application requests dial or the phone rings while the modem is in answer mode

The wake policy for the modem is very simple: When the phone rings and wake is enabled, wake the system.

Based on that policy, the modem and the COM port to which it is attached can be implemented in hardware as shown in Figure 3-2. This is just an example for illustrating features of ACPI. This example is not intended to describe how OEMs should build hardware.

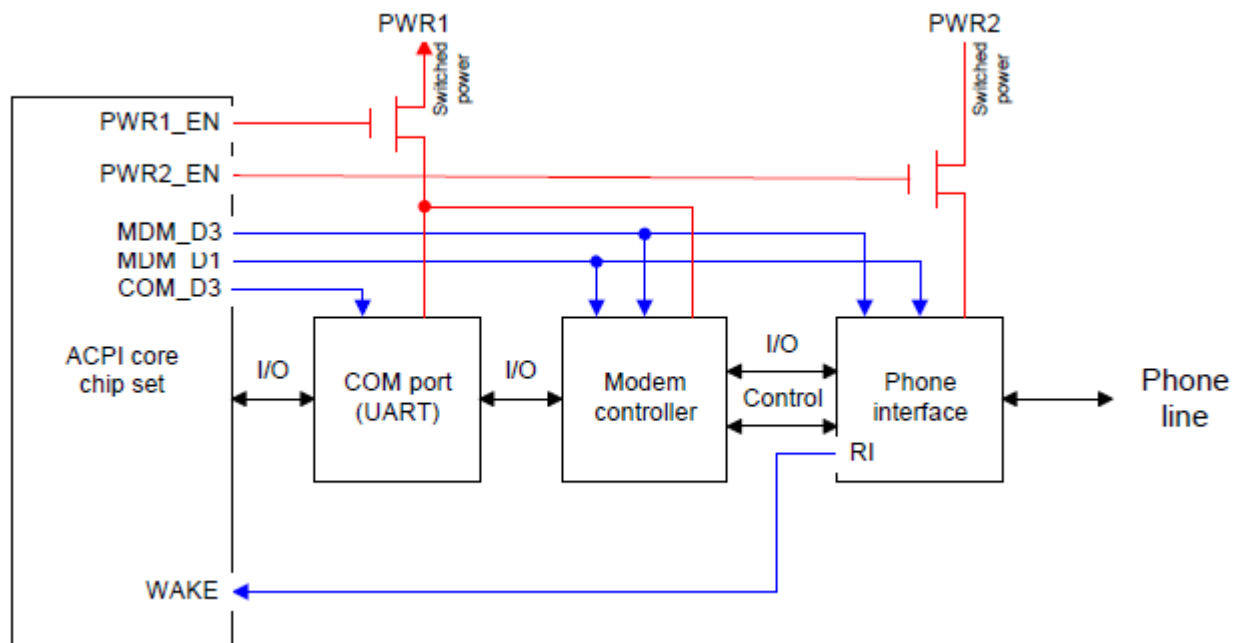

Fig. 3.2: Example Modem and COM Port Hardware

Note: Although not shown above, each discrete part has some isolation logic so that the part is isolated when power is removed from it. Isolation logic controls are implemented as power resources in the ACPI Differentiated Description

Block so that devices are isolated as power planes are sequenced off.

3.4.5.1 Obtaining the Modem Capabilities

The OS determines the capabilities of this modem when it enumerates the modem by reading the modem's entry in the Differentiated Definition Block. In this case, the entry for the modem would report:

The device supports D0, D1, and D3:

- D0 requires PWR1 and PWR2 as power resources D1 requires PWR1 as a power resource (D3 implicitly requires no power resources)
- To wake the system, the modem needs no power resources (implying it can wake the system from D0, D1, and D3)

Control methods for setting power state and resources

3.4.5.2 Setting the Modem Power State

While the OS is running (G0 state), it switches the modem to different power states according to the power policy defined for modems.

When an application opens the COM port, the OS turns on the modem by putting it in the D0 state. Then if the application puts the modem in answer mode, the OS puts the modem in the D1 state to wait for the call. To make this power-down transition, OSPM first runs a control method (`_PS1`) provided in the modem's entry to put the device in the D1 state. In this example, this control method asserts the `MDM_D1` signal that tells the modem controller to go into a low-power mode. OSPM then checks to see what power resources are no longer needed by the modem device. In this case, PWR2 is no longer needed. Then it checks to make sure no other device in the system requires the use of the PWR2 power resource. If the resource is no longer needed, the OSPM uses the `_OFF` control method associated with that power resource in the Differentiated Definition Block to turn off the PWR2 power plane. This control method sends the appropriate commands to the core chip set to stop asserting the `PWR2_EN` line.

OSPM does not always turn off power resources when a given device is put in a lower power state. For example, assume that the PWR1 power plane also powers an active line printer (LPT) port. Suppose the user terminates the modem application, causing the COM port to be closed, and therefore causing the modem to be shut off (state D3). As always, OSPM begins the state transition process by running the modem's control method to switch the device to the D3 power state. The control method causes the `MDM_D3` line to be asserted. Notice that these registers might not be in the device itself. For example, the control method could read the register that controls `MDM_D3`. The modem controller now turns off all its major functions so that it draws little power, if any, from the PWR1 line. OSPM continues by checking to see which power resources are no longer needed. Because the LPT port is still active, PWR1 is in use. OSPM does not turn off the PWR1 resource. Because the COM port is closed, the same sequence of events take place to put it in the D3 state, but the power resource is not turned off due to the LPT dependency.

3.4.5.3 Obtaining the Modem Power Status

Integrated modems have no batteries; the only power status information for the device is the power state of the modem. To determine the modem's current power state (D0-D3), OSPM runs a control method (`_PSC`) supplied in the modem's entry in the Differentiated Definition Block. This control method reads from the necessary registers to determine the modem's power state.

3.4.5.4 Waking the System

As indicated in the modem capabilities, this modem can wake the machine from any device power state. Before putting the system in a Sleep or LPI state, the OS enables wake on any devices that applications have requested to be able to wake the system. Then, it chooses the deepest sleeping or LPI state that can still provide the power resources necessary to allow all enabled wake devices to wake the system. Next, the OS puts each of those devices in the appropriate power state. In this case, the OS puts the modem in the D3 state because it supports wake from that state. Finally, the OS puts the system into a sleep or LPI state.

Waking the system via modem starts with the modem's phone interface asserting its ring indicate (RI) line when it detects a ring on the phone line. This line is routed to the core logic to generate a wake event. The chipset then wakes the system and the hardware will eventually pass control back to the OS (the wake mechanism differs depending on the sleeping state, or LPI). After the OS is running, it puts the device in the D0 state and begins handling interrupts from the modem to process the event.

3.5 Processor Power Management

To further save power in the Working state, the OS puts the CPU into low-power states (C1, C2, and C3) when the OS is idle. In these low-power states, the CPU does not run any instructions, and wakes when an interrupt, such as the OS scheduler's timer interrupt, occurs.

The OS determines how much time is being spent in its idle loop by reading the ACPI Power Management Timer. This timer runs at a known, fixed frequency and allows the OS to precisely determine idle time. Depending on this idle time estimate, the OS will put the CPU into different quality low-power states (which vary in power and latency) when it enters its idle loop.

The CPU states are defined in detail in *Processor Configuration and Control*

3.6 Device and Processor Performance States

This section describes the concept of device and processor performance states. Device and processor performance states (Px states) are power consumption and capability states within the active/executing states, C0 for processors and D0 for devices. Performance states allow OSPM to make tradeoffs between performance and energy conservation. Device and processor performance states have the greatest impact when the states invoke different device and processor efficiency levels as opposed to a linear scaling of performance and energy consumption. Since performance state transitions occur in the active/executing device states, care must be taken to ensure that performance state transitions do not adversely impact the system.

Examples of device performance states include:

- A hard drive that provides levels of maximum throughput that correspond to levels of power consumption.
- An LCD panel that supports multiple brightness levels that correspond to levels of power consumption.
- A graphics component that scales performance between 2D and 3D drawing modes that corresponds to levels of power consumption.
- An audio subsystem that provides multiple levels of maximum volume that correspond to levels of maximum power consumption.
- A Direct-RDRAMTM controller that provides multiple levels of memory throughput performance, corresponding to multiple levels of power consumption, by adjusting the maximum bandwidth throttles.

Processor performance states are described in *Processor Configuration and Control*

3.7 Configuration and “Plug and Play”

In addition to power management, ACPI interfaces provide controls and information that enable OSPM to configure the required resources of motherboard devices along with their dynamic insertion and removal. ACPI Definition Blocks, including the Differentiated System Description Table (DSDT) and Secondary System Description Tables (SSDTs), describe motherboard devices in a hierarchical format called the ACPI namespace. The OS enumerates motherboard devices simply by reading through the ACPI Namespace looking for devices with hardware IDs.

Each device enumerated by ACPI includes ACPI-defined objects in the ACPI Namespace that report the hardware resources that the device could occupy, an object that reports the resources that are currently used by the device, and objects for configuring those resources. The information is used by the Plug and Play OS (OSPM) to configure the devices.

Note: When preparing to boot a system, the platform boot firmware only needs to configure boot devices. This includes boot devices described in the ACPI system description tables as well as devices that are controlled through other standards.

3.7.1 Device Configuration Example: Configuring the Modem

Returning to the modem device example above, the OS will find the modem and load a driver for it when the OS finds it in the DSDT. This table will have control methods that give the OS the following information:

- The device can use IRQ 3, I/O 3F8-3FF or IRQ 4, I/O 2E8-2EF
- The device is currently using IRQ 3, I/O 3F8-3FF

The OS configures the modem’s hardware resources using Plug and Play algorithms. It chooses one of the supported configurations that does not conflict with any other devices. Then, OSPM configures the device for those resources by running a control method supplied in the modem’s section of the Differentiated Definition Block. This control method will write to any I/O ports or memory addresses necessary to configure the device to the given resources.

3.7.2 NUMA Nodes

Systems employing a Non Uniform Memory Access (NUMA) architecture contain collections of hardware resources including processors, memory, and I/O buses, that comprise what is commonly known as a “NUMA node”. Processor accesses to memory or I/O resources within the local NUMA node is generally faster than processor accesses to memory or I/O resources outside of the local NUMA node. ACPI defines interfaces that allow the platform to convey NUMA node topology information to OSPM both statically at boot time and dynamically at run time as resources are added or removed from the system.

3.8 System Events

ACPI includes a general event model used for Plug and Play, Thermal, and Power Management events. There are two registers that make up the event model: an event status register and an event enable register.

When an event occurs, the core logic sets a bit in the status register to indicate the event. If the corresponding bit in the enable register is set, the core logic will assert the SCI to signal the OS. When the OS receives this interrupt, it will run the control methods corresponding to any bits set in the event status register. These control methods use AML commands to tell the OS what event occurred.

For example, assume a machine has all of its Plug and Play, Thermal, and Power Management events connected to the same pin in the core logic. The event status and event enable registers would only have one bit each: the bit corresponding to the event pin.

When the system is docked, the core logic sets the status bit and signals the SCI. The OS, seeing the status bit set, runs the control method for that bit. The control method checks the hardware and determines the event was a docking event (for example). It then signals to the OS that a docking event has occurred, and can tell the OS specifically where in the device hierarchy the new devices will appear.

Since the event model registers are generalized, they can describe many different platform implementations. The single pin model above is just one example. Another design might have Plug and Play, Thermal, and Power Management events wired to three different pins so there would be three status bits (and three enable bits). Yet another design might have every individual event wired to its own pin and status bit. This design, at the opposite extreme from the single pin design, allows very complex hardware, yet very simple control methods. Countless variations in wiring up events are possible. However, note that care must be taken to ensure that if events share a signal that the event that generated the signal can be determined in the corresponding event handling control method allowing the proper device notification to be sent.

3.9 Battery Management

Battery management policy moves from the APM BIOS to the ACPI-compatible OS. Batteries must comply with the requirements of their associated interfaces, as described either herein or in other applicable standards. The OS may choose to alter the behavior of the battery, for example, by adjusting the Low Battery or Battery Warning trip point. When there are multiple batteries present, the battery subsystem is not required to perform any synthesis of a “composite battery” from the data of the separate batteries. In cases where the battery subsystem does not synthesize a “composite battery” from the separate battery’s data, the OS must provide that synthesis.

An ACPI-compatible battery device needs either a Smart Battery subsystem interface or a Control Method Battery interface.

- Smart Battery is controlled by the OS directly through the embedded controller (EC). See [Section 10.1](#) and [Section 12.9](#) for more information.
- Control Method Battery is completely accessed by AML code control methods, allowing the OEM to choose any type of battery and any kind of communication interface supported by ACPI. See [Section 10.2](#) for more information.

This section describes concepts common to all battery types.

3.9.1 Battery Communications

Both the Smart Battery and Control Method Battery interfaces provide a mechanism for the OS to query information from the platform’s battery system. This information may include full charged capacity, present battery capacity, rate of discharge, and other measures of the battery’s condition. All battery system types must provide notification to the OS when there is a change such as inserting or removing a battery, or when a battery starts or stops discharging. Smart Batteries and some Control Method Batteries are also able to give notifications based on changes in capacity. Smart batteries provide extra information such as estimated run-time, information about how much power the battery is able to provide, and what the run-time would be at a predetermined rate of consumption.

3.9.2 Battery Capacity

Each battery must report its designed capacity, latest full-charged capacity, and present remaining capacity. Remaining capacity decreases during usage, and it also changes depending on the environment. Therefore, the OS must use latest full-charged capacity to calculate the battery percentage. In addition the battery system must report warning and low battery levels at which the user must be notified and the system transitioned to a sleeping state. See Fig. 3.3 for the relation of these five values.

A system may use either rate and capacity [mA/mAh] or power and energy [mW/mWh] for the unit of battery information calculation and reporting. Mixing [mA] and [mW] is not allowed on a system.

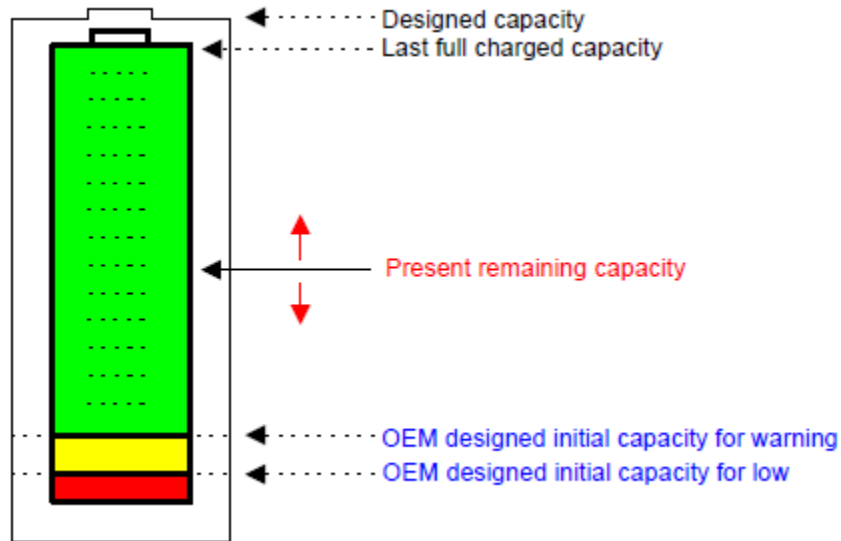

Fig. 3.3: Reporting Battery Capacity

3.9.3 Battery Gas Gauge

At the most basic level, the OS calculates Remaining Battery Percentage [%] using the following formula:

$$\text{Remaining Battery Percentage}[\%] = \frac{\text{Battery Remaining Capacity [mAh/mWh]}}{\text{Last Full Charged Capacity [mAh/mWh]}} * 100$$

Fig. 3.4: Formula for Remaining Battery Percentage

Control Method Battery also reports the Present Drain Rate [mA or mW] for calculating the remaining battery life. At the most basic level, Remaining Battery life is calculated by following formula:

$$\text{Remaining Battery Life [h]} = \frac{\text{Battery Remaining Capacity [mAh/mWh]}}{\text{Battery Present Drain Rate [mA/mW]}}$$

Fig. 3.5: Formula for the Present Drain Rate

Smart Batteries also report the present rate of drain, but since they can directly report the estimated run-time, this function should be used instead as it can more accurately account for variations specific to the battery.

3.9.4 Low Battery Levels

A system has an OEM-designed initial capacity for warning, initial capacity for low, and a critical battery level or flag. The values for warning and low represent the amount of energy or battery capacity needed by the system to take certain actions. The critical battery level or flag is used to indicate when the batteries in the system are completely drained. OSPM can determine independent warning and low battery capacity values based on the OEM-designed levels, but cannot set these values lower than the OEM-designed values, as shown in the figure below.

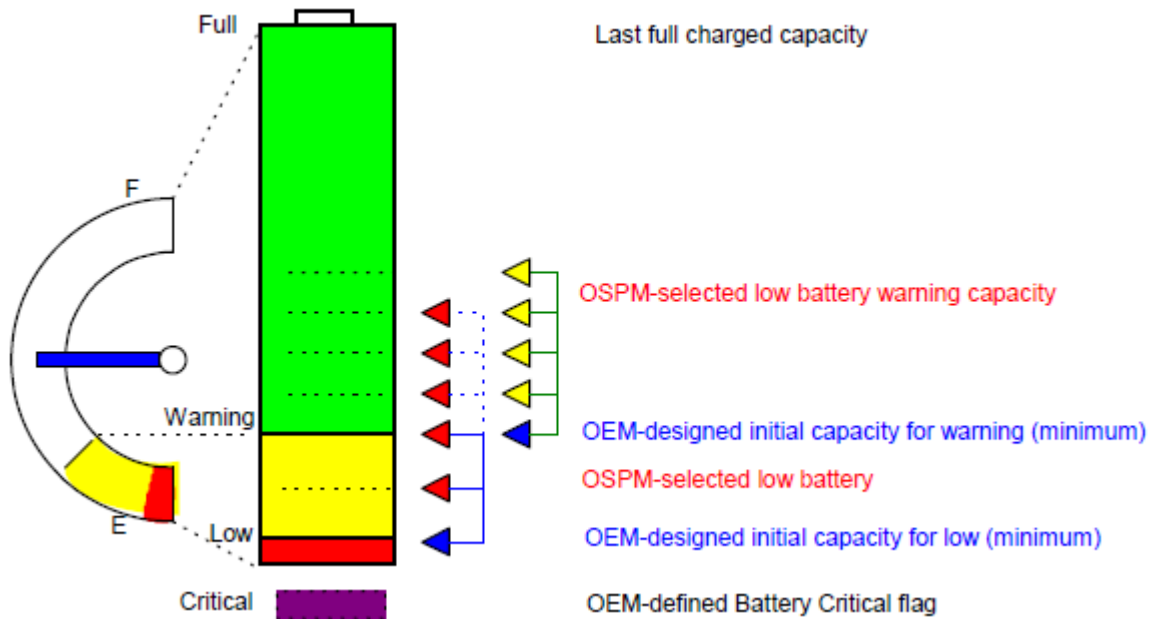

Fig. 3.6: Low Battery and Warning

Each Control Method Battery in a system reports the OEM-designed initial warning capacity and OEM-designed initial low capacity as well as a flag to report when that battery has reached or is below its critical energy level. Unlike Control Method Batteries, Smart Batteries are not necessarily specific to one particular machine type, so the OEM-designed warning, low, and critical levels are reported separately in a Smart Battery Table described in *Smart Battery Table (SBST)*.

The table below describes how these values should be set by the OEM and interpreted by the OS.

Table 3.1: Low Battery Levels

Level	Description
Warning	When the total available energy (mWh) or capacity (mAh) in the batteries falls below this level, the OS will notify the user through the UI. This value should allow for a few minutes of run-time before the “Low” level is encountered so the user has time to wrap up any important work, change the battery, or find a power outlet to plug the system in.

continues on next page

Table 3.1 – continued from previous page

Low	This value is an estimation of the amount of energy or battery capacity required by the system to transition to any supported sleeping state. When the OS detects that the total available battery capacity is less than this value, it will transition the system to a user defined system state (S1-S4). In most situations this should be S4 so that system state is not lost if the battery eventually becomes completely empty. The design of the OS should consider that users of a multiple battery system may remove one or more of the batteries in an attempt to replace or charge it. This might result in the remaining capacity falling below the “Low” level not leaving sufficient battery capacity for the OS to safely transition the system into the sleeping state. Therefore, if the batteries are discharging simultaneously, the action might need to be initiated at the point when both batteries reach this level.
Critical	The Critical battery state indicates that all available batteries are discharged and do not appear to be able to supply power to run the system any longer. When this occurs, the OS must attempt to perform an emergency shutdown as described below. For a smart battery system, this would typically occur when all batteries reach a capacity of 0, but an OEM may choose to put a larger value in the Smart Battery Table to provide an extra margin of safety. For a Control Method Battery system with multiple batteries, the flag is reported per battery. If any battery in the system is in a critically low state and is still providing power to the system (in other words, the battery is discharging), the system is considered to be in a critical energy state. The <code>_BST</code> control method is required to return the Critical flag on a discharging battery only when all batteries have reached a critical state; the ACPI system firmware is otherwise required to switch to a non-critical battery.

3.9.4.1 Emergency Shutdown

Running until all batteries in a system are critical is not a situation that should be encountered normally, since the system should be put into a sleeping state when the battery becomes low. In the case that this does occur, the OS should take steps to minimize any damage to system integrity. The emergency shutdown procedure should be designed to minimize bad effects based on the assumption that power may be lost at any time. For example, if a hard disk is spun down, the OS should not try to spin it up to write any data, since spinning up the disk and attempting to write data could potentially corrupt files if the write were not completed. Even if a disk is spun up, the decision to attempt to save even system settings data before shutting down would have to be evaluated since reverting to previous settings might be less harmful than having the potential to corrupt the settings if power was lost halfway through the write operation.

3.9.5 Battery Calibration

The reported capacity of many batteries generally degrade over time, providing less run time for the user. However, it is possible with many battery systems to provide more usable runtime on an old battery if a calibration or conditioning cycle is run occasionally. The user has typically been able to perform a calibration cycle either by going into the platform boot firmware setup menu, or by running a custom driver and calibration application provided by the OEM. The calibration process typically takes several hours, and the laptop must be plugged in during this time. Ideally the application that controls this should make this as good of a user experience as possible, for example allowing the user to schedule the system to wake up and perform the calibration at some time when the system will not be in use. Since the calibration user experience does not need to be different from system to system it makes sense for this service to be provided by the OSPM. In this way OSPM can provide a common experience for end users and eliminate the need for OEMs to develop custom battery calibration software.

In order for OSPM to perform generic battery calibration, generic interfaces to control the two basic calibration functions are required. These functions are defined in *Power Source and Power Meter Devices* and *_BST (Battery Status)*. First, there is a means to detect when it would be beneficial to calibrate the battery. Second there is a means to perform that calibration cycle. Both of those functions may be implemented by dedicated hardware such as a battery controller chip, by firmware in the embedded controller, by the platform firmware, or by OSPM. From here on any

function implemented through AML, whether or not the AML code relies on hardware, will be referred to as “AML controlled” since the interface is the same whether the AML passes control to the hardware or not.

Detection of when calibration is necessary can be implemented by hardware or AML code and be reported through the `_BMD` method. Alternately, the `_BMD` method may simply report the number of cycles before calibration should be performed and let the OS attempt to count the cycles. A counter implemented by the hardware or the platform firmware will generally be more accurate since the batteries can be used without the OS running, but in some cases, a system designer may opt to simplify the hardware or firmware implementation.

When calibration is desirable and the user has scheduled the calibration to occur, the calibration cycle can be AML controlled or OSPM controlled. OSPM can only implement a very simple algorithm since it doesn't have knowledge of the specifics of the battery system. It will simply discharge the battery until it quits discharging, then charge it until it quits charging. In the case where the AC adapter cannot be controlled through the `_BMC`, it will prompt the user to unplug the AC adapter and reattach it after the system powers off. If the calibration cycle is controlled by AML, the OS will initiate the calibration cycle by calling `_BMC`. That method will either give control to the hardware, or will control the calibration cycle itself. If the control of the calibration cycle is implemented entirely in AML code, the platform runtime firmware may avoid continuously running AML code by having the initial call to `_BMC` start the cycle, set some state flags, and then exit. Control of later parts of the cycle can be accomplished by putting code that checks these state flags in the battery event handler (`_Qxx`, `_Lxx`, or `_Exx`).

Details of the control methods for this interface are defined in *Control Method Batteries*.

3.9.6 Battery Charge Limiting

If the Platform is said to support Battery Charge Limiting feature, it must:

1. Advertise true charge level to the OSPM, at all times for all installed batteries
2. Limit the battery from reaching its Full Charge Capacity when Battery Charge Limiting is active
3. Set `_BST.Battery State.Bit[3]` when Battery Charge Limiting is active
4. Ensure that `_BST.Battery State (Bit 0 and Bit 1)` reflect true charging/discharging state of the battery

OSPM must recognize the following settings:

Table 3.2: **Battery Charge Limiting States**

<code>_BST.Battery State.Bit[3]</code>	<code>_BST.Battery State.Bit[0]</code>	<code>_BST.Battery State.Bit[1]</code>	Interpretation
Cleared	N/A	N/A	Battery Charge Limiting is disengaged
Set	Cleared	Cleared	Battery Charge Limiting is engaged, and the battery has reached the steady state, it will not be charged or discharged
Set	Cleared	Set	Battery Charge Limiting is engaged, and the battery has not reached the steady state
Set	Set	Cleared	Battery Charge Limiting is engaged, and the battery has not reached the steady state

3.10 Thermal Management Concepts

ACPI allows the OS to play a role in the thermal management of the system while maintaining the platform's ability to mandate cooling actions as necessary. In the passive cooling mode, OSPM can make cooling decisions based on application load on the CPU as well as the thermal heuristics of the system. OSPM can also gracefully shutdown the computer in case of high temperature emergencies.

The ACPI thermal design is based around regions called thermal zones. Generally, the entire PC is one large thermal zone, but an OEM can partition the system into several logical thermal zones if necessary. *Thermal Zone* is an example mobile PC diagram that depicts a single thermal zone with a central processor as the thermal-coupled device. In this example, the whole notebook is covered as one large thermal zone. This notebook uses one fan for active cooling and the CPU for passive cooling.

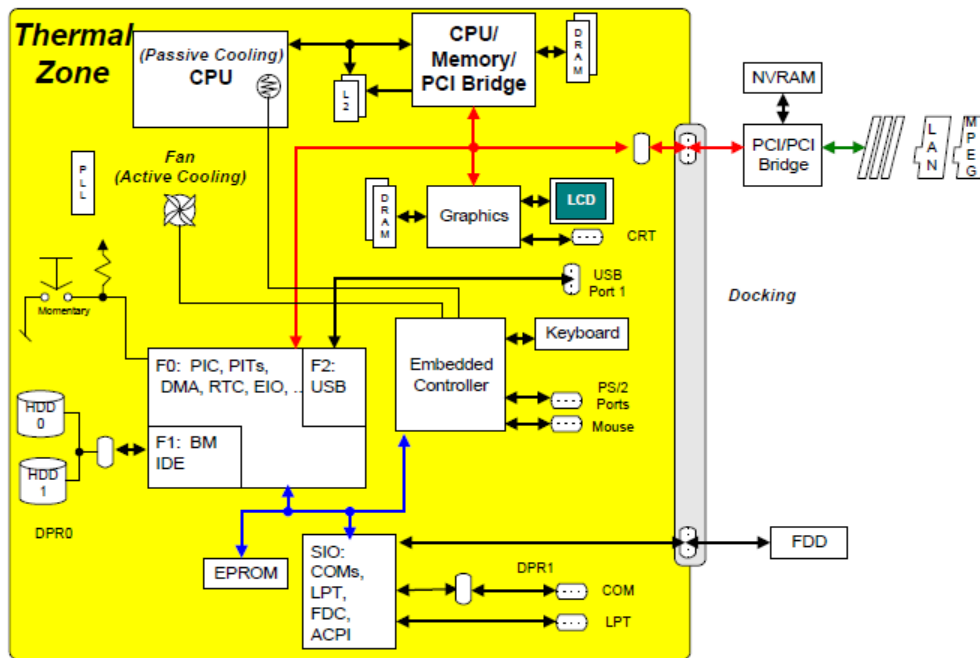

Fig. 3.7: Thermal Zone

The following sections are an overview of the thermal control and cooling characteristics of a computer. For some thermal implementation examples on an ACPI platform, see Section 11.6

3.10.1 Active and Passive Cooling Modes

ACPI defines two cooling modes, Active and Passive:

Passive cooling OS reduces the power consumption of devices at the cost of system performance to reduce the temperature of the system.

Active cooling OS increases the power consumption of the system (for example, by turning on a fan) to reduce the temperature of the system.

These two cooling modes are inversely related to each other. Active cooling requires increased power to reduce the heat within the system while Passive cooling requires reduced power to decrease the temperature. The effect of this relationship is that Active cooling allows maximum system performance, but it may create undesirable fan noise, while Passive cooling reduces system performance, but is inherently quiet.

3.10.2 Performance vs. Energy Conservation

A robust OSPM implementation provides the means for the end user to convey to OSPM a preference (or a level of preference) for either performance or energy conservation. Allowing the end user to choose this preference is most critical to mobile system users where maximizing system run-time on a battery charge often has higher priority over realizing maximum system performance.

A user's preference for performance corresponds to the Active cooling mode while a user's preference for energy conservation corresponds to the Passive cooling mode. ACPI defines an interface to convey the cooling mode to the platform. Active cooling can be performed with minimal OSPM thermal policy intervention. For example, the platform indicates through thermal zone parameters that crossing a thermal trip point requires a fan to be turned on. Passive cooling requires OSPM thermal policy to manipulate device interfaces that reduce performance to reduce thermal zone temperature.

3.10.3 Acoustics (Noise)

Active cooling mode generally implies that fans will be used to cool the system and fans vary in their audible output. Fan noise can be quite undesirable given the loudness of the fan and the ambient noise environment. In this case, the end user's physical requirement for fan silence may override the preference for either performance or energy conservation.

A user's desire for fan silence corresponds to the Passive cooling mode. Accordingly, a user's desire for fan silence also means a preference for energy conservation.

For more information on thermal management and examples of platform settings for active and passive cooling, see [Section 3.10](#)

3.10.4 Multiple Thermal Zones

The basic thermal management model defines one thermal zone, but in order to provide extended thermal control in a complex system, ACPI specifies a multiple thermal zone implementation. Under a multiple thermal zone model, OSPM will independently manage several thermal-coupled devices and a designated thermal zone for each thermal-coupled device, using Active and/or Passive cooling methods available to each thermal zone. Each thermal zone can have more than one Passive and Active cooling device. Furthermore, each zone might have unique or shared cooling resources. In a multiple thermal zone configuration, if one zone reaches a critical state then OSPM must shut down the entire system.

3.11 Flexible Platform Architecture Support

ACPI defines mechanisms and models to accommodate platform architectures that deviate from the traditional PC. ACPI provides support for platform technologies that enable lower-power, lower cost, more design flexibility and more device diversity. This support is described in the following sections, and detailed in later chapters.

3.11.1 Hardware-reduced ACPI

ACPI offers an alternative platform interface model that removes ACPI hardware requirements for platforms that do not implement the PC Architecture. In the Hardware-reduced ACPI model, the Fixed hardware interface requirements of Chapter 4 are removed, and Generic hardware interfaces are used instead. This provides the level of flexibility needed to innovate and differentiate in low-power hardware designs while enabling support by multiple Operating Systems.

Hardware-reduced ACPI has the following requirements:

- UEFI firmware interface for boot (Legacy BIOS is not supported).
- Boot in ACPI mode only (ACPI Enable, ACPI Disable, SMI_CMD and Legacy mode are not supported)
- No hardware resource sharing between OSPM and other asynchronous operating environments, such as UEFI Runtime Services or System Management Mode. (The Global Lock is not supported)
- No dependence on OS-support for maintaining cache coherency across processor sleep states (Bus Master Reload and Arbiter Disable are not supported)
- GPE block devices are not supported

Systems that do not meet the above requirements must implement the ACPI Fixed Hardware interface.

3.11.1.1 Interrupt-based Wake Events

On HW-reduced ACPI platforms, wakeup is an attribute of connected interrupts. Interrupts that are designed to wake the processor or the entire platform are defined as wake-capable. Wake-capable interrupts, when enabled by OSPM, wake the system when they assert.

3.11.2 Low-Power Idle

Platform architectures may support hardware power management models other than the traditional ACPI Sleep/Resume model. These are typically implemented in proprietary hardware and are capable of delivering low-latency, connected idle while saving as much energy as ACPI Sleep states. To support the diversity of hardware implementations, ACPI provides a mechanism for the platform to indicate to OSPM that such capability is available.

3.11.2.1 Low Power S0 Idle Capable Flag

This flag in the FADT informs OSPM whether a platform has advanced idle power capabilities such that S0 idle achieves savings similar to or better than those typically achieved in S3. With this flag, OSPM can keep the system in S0 idle for its low-latency response and its connectedness rather than transitioning to a system sleep state which has neither. The flag enables support for a diversity of platform implementations: traditional Sleep/Resume systems, systems with advanced idle power, systems that support neither, and systems that can support both, depending on the capabilities of the installed OS.

3.11.3 Connection Resources

General-purpose I/O (GPIO) and Simple Peripheral Bus (SPB) controllers are hardware resources provided in silicon solutions to enable flexible configuration of a broad range of system designs. These controllers can provide input, output, interrupt and serial communication connections to arbitrary devices in a system. The function to which one of these connections is put depends on the specific device involved and the needs of the platform design. In order to support these platform technologies, ACPI defines a general abstraction for flexible connections.

In order to maintain compatibility with existing software models, ACPI abstracts these connections as hardware resources.

The Connection Resource abstraction mirrors the hardware functionality of GPIO and SPB controllers. Like other resources, these connections are allocated and configured before use. With the resources described by the platform, OSPM abstracts the underlying configuration from device drivers. Drivers, then, can be written for the device's function only, and reused with that functional hardware regardless of how it is integrated into a given system.

The key aspects of the Connection Resource abstraction are:

- GPIO and SPB controllers are enumerated as devices in the ACPI Namespace.
- GPIO Connection and SPB Connection resource types are defined.
- Namespace devices that are connected to GPIO or SPB controllers use Resource Template Macros to add Connection Resources to their resource methods (`_CRS`, `_SRS`, etc.).
- GPIO Connection Resources can be designated by the platform for use as *GPIO-signaled ACPI Events*.
- Connection Resources can be used by AML methods to access pins and peripherals through GPIO and SPB operation regions.

3.11.3.1 Supported Platforms

The HW-reduced ACPI and Low power S0 Idle Capable flags combine to represent 4 platform types that can be implemented. The following table enumerates these, as well as the intended OSPM behavior and specific platform requirements.

Table 3.3: Implementable Platform Types

Low Power S0 Idle Capable	Hardware-reduced ACPI	OSPM Behavior	Platform Implementation
0	0	Fixed hardware interface accessed for features, events and system power management. Optionally accesses GPIO-signaled ACPI events if implemented in ACPI FW. Traditional Sleep/Resume power management.	Implement Fixed-feature hardware interface. Optionally implements GPIO-signaled ACPI events.
0	1	Fixed-feature hardware interface not accessed. Sleep/Resume Power Management using FADT SLEEP_*_REG fields and Interrupt-based wake signaling.	Implement GPIO-signaled ACPI Events; Implement software alternatives to any ACPI fixed features, including the Sleep registers. Implement wake-capable interrupts for wake events.

continues on next page

Table 3.3 – continued from previous page

1	0	Fixed hardware interface accessed for features and events. Platform-specific Low-power Idle power management. Optionally accesses GPIO-sigaled ACPI events if implemented in ACPI FW.	Implement Fixed-feature hardware interface. Optionally implements GPIO-sigaled ACPI events. Implement low-power hardware such that the platform achieves power savings in S0 similar to or better than those typically achieved in S3.
1	1	Fixed-feature hardware interface not accessed. Platform-specific Low-power Idle power management.	Implement <i>GPIO-sigaled ACPI Events</i> ; Implement software alternatives to any ACPI fixed features desired; Implement wake-capable interrupts for any wake events. Implement low-power hardware such that the platform achieves power savings in S0 similar to or better than those typically achieved in S3.

ACPI HARDWARE SPECIFICATION

ACPI defines standard interface mechanisms that allow an ACPI-compatible OS to control and communicate with an ACPI-compatible hardware platform. These interface mechanisms are optional (See “Hardware-Reduced ACPI”, below). However, if the ACPI Hardware Specification is implemented, platforms must comply with the requirements in this section.

This section describes the hardware aspects of ACPI.

ACPI defines “hardware” as a programming model and its behavior. ACPI strives to keep much of the existing legacy programming model the same; however, to meet certain feature goals, designated features conform to a specific addressing and programming scheme. Hardware that falls within this category is referred to as “fixed.”

Although ACPI strives to minimize these changes, hardware engineers should read this section carefully to understand the changes needed to convert a legacy-only hardware model to an ACPI/Legacy hardware model or an ACPI-only hardware model.

ACPI classifies hardware into two categories: Fixed or Generic. Hardware that falls within the fixed category meets the programming and behavior specifications of ACPI. Hardware that falls within the generic category has a wide degree of flexibility in its implementation.

4.1 Hardware-Reduced ACPI

For certain classes of systems the ACPI Hardware Specification may not be adequate. Examples include legacy-free, UEFI-based platforms with recent processors, and those implementing mobile platform architectures. For such platforms, a Hardware-reduced ACPI mode is defined. Under this definition, the ACPI Fixed Hardware interface is not implemented, and software alternatives for many of the features it supports are used instead. Note, though, that Hardware-reduced ACPI is not intended to support every possible ACPI system that can be built today. Rather, it is intended to introduce new systems that are designed to be HW-reduced from the start. The ACPI HW Specification should be used if the platform cannot be designed to work without it. Specifically, the following features are not supported under the HW-reduced definition:

- The Global Lock, SMI_CMD, ACPI Enable and ACPI Disable. Hardware-reduced ACPI systems always boot in ACPI mode, and do not support hardware resource sharing between OSPM and other asynchronous operating environments, such as UEFI Runtime Services or System Management Mode.
- Bus Master Reload and Arbiter Disable. Systems that depend on OS use of these bits to maintain cache coherency across processor sleep states are not supported.
- GPE block devices are not supported.

Platforms that require the above features must implement the ACPI Hardware Specification.

Platforms that are designed for the Hardware-reduced ACPI definition must implement Revision 5 or greater of the Fixed ACPI Descriptor Table, and must set the HW_REDUCED_ACPI flag in the Flags field.

Note: FFH is permitted and applicable to both full and HW-reduced ACPI implementations.

4.1.1 Hardware-Reduced Events

HW-reduced ACPI platforms require alternatives to some of the features supported in the ACPI HW Specification, where none already exists. There are two areas that require such alternatives: The ACPI Platform Event Model, and System and Device Wakeup.

4.1.1.1 GPIO-Signaled Events or Interrupt Signaled Events

General Purpose Input/Output (GPIO) hardware can be used for signaling platform events. GPIO HW is a generalization of the GPE model, and is a shared hardware resource used for many applications. ACPI support for GPIO is described in section *Connection Resources*. ACPI 6.1 introduces the capability to signal events via interrupts. See *Interrupt-signaled ACPI events* for further details.

GPIO based event signaling is provided through GPIO interrupt connections, which describe the connection to a GPIO controller and pin, and which are mapped to the ACPI Event Handling mechanism via the ACPI Event Information namespace object (`_AEI`). OSPM treats GPIO Interrupt Connections listed in `_AEI` exactly as it does SCI interrupts: it executes the Event Method associated with the specific event. The name of the method to run is determined by the pin information contained in the GPIO Interrupt Connection resource. See *GPIO-signaled ACPI Events* for further details.

GPIO-signaled events can also be wake events, just as GPE events can on traditional ACPI platforms. Designating which events are wake events is done through attributes of the GPIO Interrupt Connection resource used. Devices may use `_PRW` to manage wake events as described in *_PRW (Power Resources for Wake)*.

Interrupt based event signaling follows a similar methodology, a generic event device (GED) is declared which in turn describes all interrupts associated with event generation. The interrupts are listed in a `_CRS` object. When an interrupt is asserted the OSPM will execute the event method (`_EVT`) declared in the GED object specifying the interrupt identifier as a parameter. In this way the interrupt can be associated with specific platform events.

4.1.1.2 Interrupt-based Wake Events

Wake events on HW-reduced ACPI platforms are always caused by an interrupt reaching the processor. Therefore, there are two requirements for waking the system from a sleep or low-power idle state, or a device from a low-power state. First, the interrupt line must be Wake-Capable. Wake-capable interrupts are designed to be able to be delivered to the processor from low-power states. This implies that it must also cause the processor and any required platform hardware to power-up so that an Interrupt Service Routine can run. Secondly, an OS driver must enable the interrupt before entering a low-power state, or before OSPM puts the system into a sleep or low-power idle state.

Wake-capable interrupts are designated as such in their Extended Interrupt or GPIO Interrupt Connection resource descriptor.

4.2 Fixed Hardware Programming Model

Because of the changes needed for migrating legacy hardware to the fixed category, ACPI limits the features specified by fixed hardware. Fixed hardware features are defined by the following criteria:

- Performance sensitive features
- Features that drivers require during wake
- Features that enable catastrophic OS software failure recovery

ACPI defines register-based interfaces to fixed hardware. CPU clock control and the power management timer are defined as fixed hardware to reduce the performance impact of accessing this hardware, which will result in more quickly reducing a thermal condition or extending battery life. If this logic were allowed to reside in PCI configuration space, for example, several layers of drivers would be called to access this address space. This takes a long time and will either adversely affect the power of the system (when trying to enter a low-power state) or the accuracy of the event (when trying to get a time stamp value).

Access to fixed hardware by OSPM allows OSPM to control the wake process without having to load the entire OS. For example, if PCI configuration space access is needed, the bus enumerator is loaded with all drivers used by the enumerator. Defining these interfaces in fixed hardware at addresses with which OSPM can communicate without any other driver's assistance, allows OSPM to gather information prior to making a decision as to whether it continues loading the entire OS or puts it back to sleep.

If elements of the OS fail, it may be possible for OSPM to access address spaces that need no driver support. In such a situation, OSPM will attempt to honor fixed power button requests to transition the system to the G2 state. In the case where OSPM event handler is no longer able to respond to power button events, the power button override feature provides a back-up mechanism to unconditionally transition the system to the soft-off state.

4.3 Generic Hardware Programming Model

Although the fixed hardware programming model requires hardware registers to be defined at specific address locations, the generic hardware programming model allows hardware registers to reside in most address spaces and provides system OEMs with a wide degree of flexibility in the implementation of specific functions in hardware. OSPM directly accesses the fixed hardware registers, but relies on OEM-provided ACPI Machine Language (AML) code to access generic hardware registers.

AML code allows the OEM to provide the means for OSPM to control a generic hardware feature's control and event logic.

The section entitled "ACPI Source Language Reference" describes the ACPI Source Language (ASL)—a programming language that OEMs use to create AML. The ASL language provides many of the operators found in common object-oriented programming languages, but it has been optimized to enable the description of platform power management and configuration hardware. An ASL compiler converts ASL source code to AML, which is a very compact machine language that the ACPI AML code interpreter executes.

AML does two things:

- Abstracts the hardware from OSPM
- Buffers OEM code from the different OS implementations

One goal of ACPI is to allow the OEM "value added" hardware to remain basically unchanged in an ACPI configuration. One attribute of value-added hardware is that it is all implemented differently. To enable OSPM to execute properly on different types of value added hardware, ACPI defines higher level "control methods" that it calls to perform an action. The OEM provides AML code, which is associated with control methods, to be executed by OSPM. By providing AML code, generic hardware can take on almost any form.

Another important goal of ACPI is to provide OS independence. To do this, the OEM AML code has to execute the same under any ACPI-compatible OS. ACPI allows for this by making the AML code interpreter part of OSPM. This allows OSPM to take care of synchronizing and blocking issues specific to each particular OS.

The generic feature model is represented in the following block diagram. In this model the generic feature is described to OSPM through AML code. This description takes the form of an object that sits in the ACPI Namespace associated with the hardware to which it is adding value.

As an example of a generic hardware control feature, a platform might be designed such that the IDE HDD's D3 state has value-added hardware to remove power from the drive. The IDE drive would then have a reference to the AML

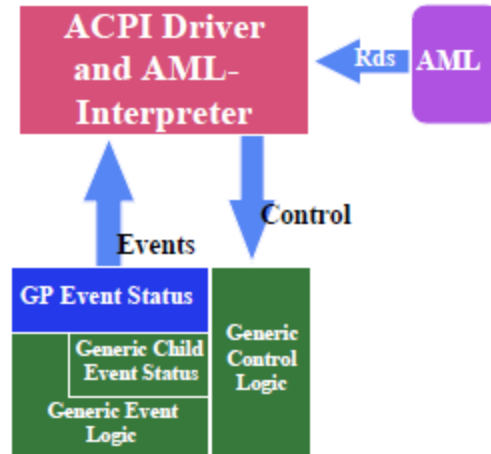

Fig. 4.1: Generic Hardware Feature Model

PowerResource object (which controls the value added power plane) in its namespace, and associated with that object would be control methods that OSPM invokes to control the D3 state of the drive:

- **_PS0**: A control method to sequence the IDE drive to the D0 state.
- **_PS3**: A control method to sequence the IDE drive to the D3 state.
- **_PSC**: A control method that returns the status of the IDE drive (on or off).

The control methods under this object provide an abstraction layer between OSPM and the hardware. OSPM understands how to control power planes (turn them on or off or to get their status) through its defined **PowerResource** object, while the hardware has platform-specific AML code (contained in the appropriate control methods) to perform the desired function. In this example, the platform would describe its hardware to the ACPI OS by writing and placing the AML code to turn the hardware off within the **_PS3** control method. This enables the following sequence:

When OSPM decides to place the IDE drive in the D3 state, it calls the IDE driver and tells it to place the drive into the D3 state (at which point the driver saves the device’s context).

When the IDE driver returns control, OSPM places the drive in the D3 state.

OSPM finds the object associated with the HDD and then finds within that object any AML code associated with the D3 state.

OSPM executes the appropriate **_PS3** control method to control the value-added “generic” hardware to place the HDD into an even lower power state.

As an example of a generic event feature, a platform might have a docking capability. In this case, it will want to generate an event. Notice that all ACPI events generate an SCI, which can be mapped to any shareable system interrupt. In the case of docking, the event is generated when a docking has been detected or when the user requests to undock the system. This enables the following sequence:

OSPM responds to the SCI and calls the AML code event handler associated with that generic event. The ACPI table associates the hardware event with the AML code event handler.

The AML-code event handler collects the appropriate information and then executes an AML Notify command to indicate to OSPM that a particular bus needs re-enumeration.

The following sections describe the fixed and generic hardware feature set of ACPI. These sections enable a reader to understand the following:

- Which hardware registers are required or optional when an ACPI feature, concept or interface is required by a design guide for a platform class

- How to design fixed hardware features
- How to design generic hardware features
- The ACPI Event Model

4.4 Diagram Legend

The hardware section uses simplified logic diagrams to represent how certain aspects of the hardware are implemented. The following symbols are used in the logic diagrams to represent programming bits:

 Write-only control bit

 Enable, control, or status bit

 Sticky status bit

 Query value

The half round symbol with an inverted “V” represents a write-only control bit. This bit has the behavior that it generates its control function when it is set. Reads to write-only bits are treated as ignore by software (the bit position is masked off and ignored).

The round symbol with an “X” represents a programming bit. As an enable or control bit, software setting or clearing this bit will result in the bit being read as set or clear (unless otherwise noted). As a status bit it directly represents the value of the signal.

The square symbol represents a sticky status bit. A sticky status bit is set by the level (not edge) of a hardware signal (active high or active low). The bit is only cleared by software writing a “1” to its bit position.

The rectangular symbol represents a query value from the embedded controller. This is the value the embedded controller returns to the system software upon a query command in response to an SCI event. The query value is associated with the event control method that is scheduled to execute upon an embedded controller event.

4.5 Register Bit Notation

Throughout this section there are logic diagrams that reference bits within registers. These diagrams use a notation that easily references the register name and bit position. The notation is as follows:

Registername.Bit

Registername contains the name of the register as it appears in this specification

Bit contains a zero-based decimal value of the bit position

For example, the SLP_EN bit resides in the PM1x_CNT register bit 13 and would be represented in diagram notation as:

SLP_EN
PM1x_CNT.13

4.6 The ACPI Hardware Model

The ACPI hardware model is defined to allow OSPM to sequence the platform between the various global system states (G0-G3) as illustrated in the following figure by manipulating the defined interfaces. When first powered on, the platform finds itself in the global system state G3 or “Mechanical Off.” This state is defined as one where power consumption is very close to zero—the power plug has been removed; however, the real-time clock device still runs off a battery. The G3 state is entered by any power failure, defined as accidental or user-initiated power loss.

The G3 state transitions into either the G0 working state or the Legacy state depending on what the platform supports. If the platform is an ACPI-only platform, then it allows a direct boot into the G0 working state by always returning the status bit `SCI_EN` set (1) (for more information, see *Legacy/ACPI Select and the SCI Interrupt*). If the platform supports both legacy and ACPI operations (which is necessary for supporting a non-ACPI OS), then it would always boot into the Legacy state (illustrated by returning the `SCI_EN` clear (0)). In either case, a transition out of the G3 state requires a total boot of OSPM.

The Legacy system state is the global state where a non-ACPI OS executes. This state can be entered from either the G3 “Mechanical Off,” the G2 “Soft Off,” or the G0 “Working” states only if the hardware supports both Legacy and ACPI modes. In the Legacy state, the ACPI event model is disabled (no SCIs are generated) and the hardware uses legacy power management and configuration mechanisms. While in the Legacy state, an ACPI-compliant OS can request a transition into the G0 working state by performing an ACPI mode request. OSPM performs this transition by writing the `ACPI_ENABLE` value to the `SML_CMD`, which generates an event to the hardware to transition the platform into ACPI mode. When hardware has finished the transition, it sets the `SCI_EN` bit and returns control back to OSPM. While in the G0 “working state,” OSPM can request a transition to Legacy mode by writing the `ACPI_DISABLE` value to the `SML_CMD` register, which results in the hardware going into legacy mode and resetting the `SCI_EN` bit LOW (for more information, see *Legacy/ACPI Select and the SCI Interrupt*).

The G0 “Working” state is the normal operating environment of an ACPI system. In this state different devices are dynamically transitioning between their respective power states (D0, D1, D2, D3hot, or D3) and processors are dynamically transitioning between their respective power states (C0, C1, C2 or C3). In this state, OSPM can make a policy decision to place the platform into the system G1 “sleeping” state. The platform can only enter a single sleeping state at a time (referred to as the global G1 state); however, the hardware can provide up to four system sleeping states that have different power and exit latencies represented by the S1, S2, S3, or S4 states. When OSPM decides to enter a sleeping state it picks the most appropriate sleeping state supported by the hardware (OS policy examines what devices have enabled wake events and what sleeping states these support). OSPM initiates the sleeping transition by enabling the appropriate wake events and then programming the `SLP_TYPx` field with the desired sleeping state and then setting the `SLP_ENx` bit. The system will then enter a sleeping state; when one of the enabled wake events occurs, it will transition the system back to the working state (for more information, see *Waking and Sleeping*).

Another global state transition option while in the G0 “working” state is to enter the G2 “soft off” or the G3 “mechanical off” state. These transitions represent a controlled transition that allows OSPM to bring the system down in an orderly fashion (unloading applications, closing files, and so on). The policy for these types of transitions can be associated with the ACPI power button, which when pressed generates an event to the power button driver. When OSPM is finished preparing the operating environment for a power loss, it will either generate a pop-up message to indicate to the user to remove power, in order to enter the G3 “Mechanical Off” state, or it will initiate a G2 “soft-off” transition by writing the value of the S5 “soft off” system state to the `SLP_TYPx` register and setting the `SLP_EN` bit.

The G1 sleeping state is represented by four possible sleeping states that the hardware can support. Each sleeping state has different power and wake latency characteristics. The sleeping state differs from the working state in that the user’s operating environment is frozen in a low-power state until awakened by an enabled wake event. No work is performed in this state, that is, the processors are not executing instructions. Each system sleeping state has requirements about who is responsible for system context and wake sequences (for more information, see *Waking and Sleeping*).

The G2 “soft off” state is an OS initiated system shutdown. This state is initiated similar to the sleeping state transition (`SLP_TYPx` is set to the S5 value and setting the `SLP_EN` bit initiates the sequence). Exiting the G2 soft-off state requires rebooting the system. In this case, an ACPI-only system will re-enter the G0 state directly (hardware returns the `SCI_EN` bit set), while an ACPI/Legacy system transitions to the Legacy state (`SCI_EN` bit is clear).

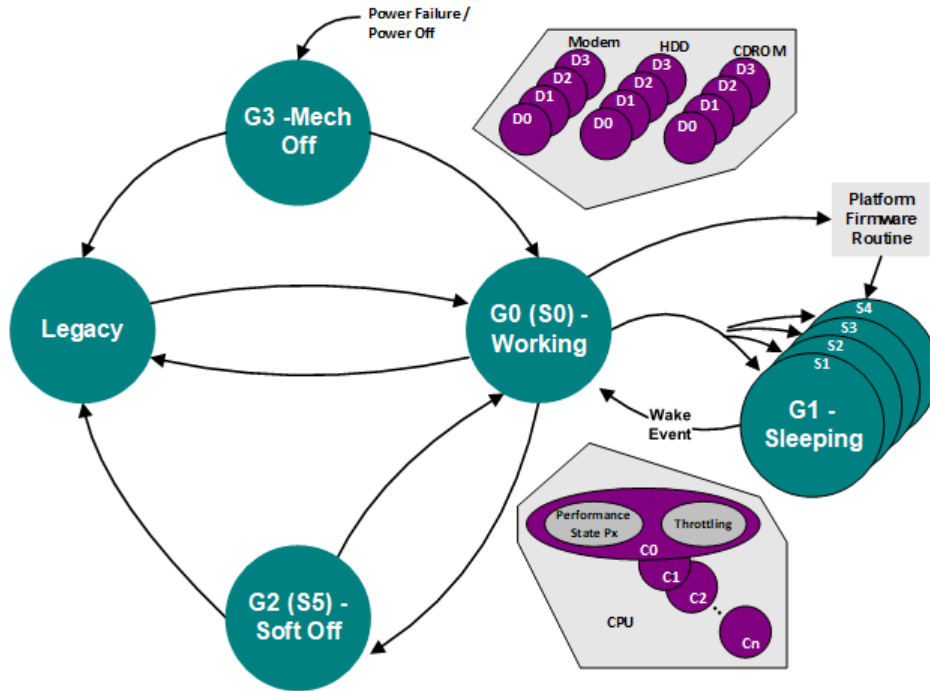

Fig. 4.2: Global States and Their Transitions

The ACPI architecture defines mechanisms for hardware to generate events and control logic to implement this behavior model. Events are used to notify OSPM that some action is needed, and control logic is used by OSPM to cause some state transition. ACPI-defined events are “hardware” or “interrupt” events. A hardware event is one that causes the hardware to unconditionally perform some operation. For example, any wake event will sequence the system from a sleeping state (S1, S2, S3, and S4 in the global G1 state) to the G0 working state (see *Example Sleeping States*).

An interrupt event causes the execution of an event handler (AML code or an ACPI-aware driver), which allows the software to make a policy decision based on the event. For ACPI fixed-feature events, OSPM or an ACPI-aware driver acts as the event handler. For generic logic events OSPM will schedule the execution of an OEM-supplied AML control method associated with the event.

For legacy systems, an event normally generates an OS-transparent interrupt, such as a System Management Interrupt, or SMI. For ACPI systems the interrupt events need to generate an OS-visible interrupt that is shareable; edge-style interrupts will not work. Hardware platforms that want to support both legacy operating systems and ACPI systems support a way of re-mapping the interrupt events between SMIs and SCIs when switching between ACPI and legacy models. This is illustrated in the following block diagram.

This example logic illustrates the event model for a sample platform that supports both legacy and ACPI event models. This example platform supports a number of external events that are power-related (power button, LID open/close, thermal, ring indicate) or Plug and Play-related (dock, status change). The logic represents the three different types of events:

OS Transparent Events

These events represent OEM-specific functions that have no OS support and use software that can be operated in an OS-transparent fashion (that is, SMIs).

Interrupt Events

These events represent features supported by ACPI-compatible operating systems, but are not supported by legacy operating systems. When a legacy OS is loaded, these events are mapped to the transparent interrupt (SMI# in this example), and when in ACPI mode they are mapped to an OS-visible shareable

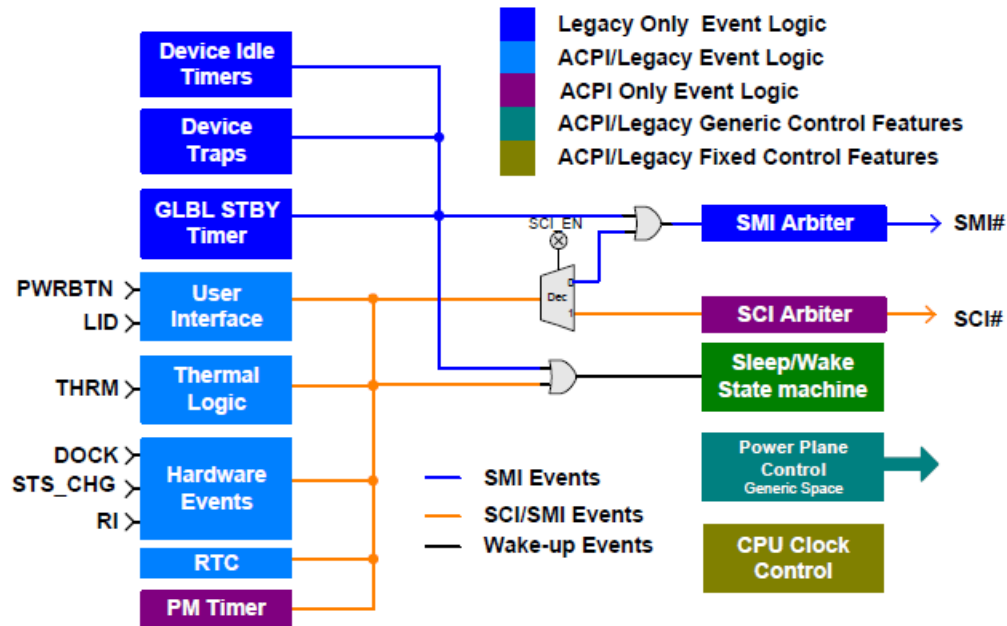

Fig. 4.3: Example Event Structure for a Legacy/ACPI Compatible Event Model

interrupt (SCI#). This logic is represented by routing the event logic through the decoder that routes the events to the SMI# arbiter when the SCI_EN bit is cleared, or to the SCI# arbiter when the SCI_EN bit is set.

Hardware events

These events are used to trigger the hardware to initiate some hardware sequence such as waking, resetting, or putting the system to sleep unconditionally.

In this example, the legacy power management event logic is used to determine device/system activity or idleness based on device idle timers, device traps, and the global standby timer. Legacy power management models use the idle timers to determine when a device should be placed in a low-power state because it is idle—that is, the device has not been accessed for the programmed amount of time. The device traps are used to indicate when a device in a low-power state is being accessed by OSPM. The global standby timer is used to determine when the system should be allowed to go into a sleeping state because it is idle—that is, the user interface has not been used for the programmed amount of time.

These legacy idle timers, trap monitors, and global standby timer are not used by OSPM in the ACPI mode. This work is handled by different software structures in an ACPI-compatible OS. For example, the driver model of an ACPI-compatible OS is responsible for placing its device into a low-power state (D1, D2, D3hot, or D3) and transitioning it back to the On state (D0) when needed. And OSPM is responsible for determining when the system is idle by profiling the system (using the PM Timer) and other knowledge it gains through its operating structure environment (which will vary from OS to OS). When the system is placed into the ACPI mode, these events no longer generate SMIs, as OSPM handles this function. These events are disabled through some OEM-proprietary method.

On the other hand, many of the hardware events are shared between the ACPI and legacy models (docking, the power button, and so on) and this type of interrupt event changes to an SCI event when enabled for ACPI. The ACPI OS will generate a request to the platform runtime firmware to enter into the ACPI mode. The firmware sets the SCI_EN bit to indicate that the system has successfully entered into the ACPI mode, so this is a convenient mechanism to map the desired interrupt (SMI or SCI) for these events (as shown in Figure 4-3).

The ACPI architecture specifies some dedicated hardware not found in the legacy hardware model: the power management timer (PM Timer). This is a free running timer that the ACPI OS uses to profile system activity. The frequency

of this timer is explicitly defined in this specification and must be implemented as described.

Although the ACPI architecture reuses most legacy hardware as is, it does place restrictions on where and how the programming model is generated. If used, all fixed hardware features are implemented as described in this specification so that OSPM can directly access the fixed hardware feature registers.

Generic hardware features are manipulated by ACPI control methods residing in the ACPI Namespace. These interfaces can be very flexible; however, their use is limited by the defined ACPI control methods (for more information, see *ACPI-Defined Devices and Device-Specific Objects*). Generic hardware usually controls power planes, buffer isolation, and device reset resources. Additionally, “child” interrupt status bits can be accessed via generic hardware interfaces; however, they have a “parent” interrupt status bit in the GP_STS register. ACPI defines eight address spaces that may be accessed by generic hardware implementations. These include:

- System I/O space
- System memory space
- PCI configuration space
- Embedded controller space
- System Management Bus (SMBus) space
- CMOS
- PCI BAR Target
- IPMI space
- Platform Communication Channel

Generic hardware power management features can be implemented accessing spare I/O ports residing in any of these address spaces. The ACPI specification defines an optional embedded controller and SMBus interfaces needed to communicate with these associated address spaces.

4.6.1 Hardware Reserved Bits

ACPI hardware registers are designed such that reserved bits always return zero, and data writes to them have no side effects. OSPM implementations must write zeros to reserved bits in enable and status registers and preserve bits in control registers, and they will treat these bits as ignored.

4.6.2 Hardware Ignored Bits

ACPI hardware registers are designed such that ignored bits are undefined and are ignored by software. Hardware-ignored bits can return zero or one. When software reads a register with ignored bits, it masks off ignored bits prior to operating on the result. When software writes to a register with ignored bit fields, it preserves the ignored bit fields.

4.6.3 Hardware Write-Only Bits

ACPI hardware defines a number of write-only control bits. These bits are activated by software writing a 1 to their bit position. Reads to write-only bit positions generate undefined results. Upon reads to registers with write-only bits, software masks out all write-only bits.

4.6.4 Cross Device Dependencies

Cross Device Dependency is a condition in which an operation to a device interferes with the operation of other unrelated devices, or allows other unrelated devices to interfere with its behavior. This condition is not supportable and can cause platform failures. ACPI provides no support for cross device dependencies and suggests that devices be designed to not exhibit this behavior. The following two examples describe cross device dependencies:

4.6.4.1 Example 1: Related Device Interference

This example illustrates a cross device dependency where a device interferes with the proper operation of other unrelated devices. Device A has a dependency that when it is being configured it blocks all accesses that would normally be targeted for Device B. Thus, the device driver for Device B cannot access Device B while Device A is being configured; therefore, it would need to synchronize access with the driver for Device A. High performance, multithreaded operating systems cannot perform this kind of synchronization without seriously impacting performance.

To further illustrate the point, assume that Device A is a serial port and Device B is a hard drive controller. If these devices demonstrate this behavior, then when a software driver configures the serial port, accesses to the hard drive need to block. This can only be done if the hard disk driver synchronizes access to the disk controller with the serial driver. Without this synchronization, hard drive data will be lost when the serial port is being configured.

4.6.4.2 Example 2: Unrelated Device Interference

This example illustrates a cross-device dependency where a device demonstrates a behavior that allows other unrelated devices to interfere with its proper operation. Device A exhibits a programming behavior that requires atomic back-to-back write accesses to successfully write to its registers; if any other platform access is able to break between the back-to-back accesses, then the write to Device A is unsuccessful. If the Device A driver is unable to generate atomic back-to-back accesses to its device, then it relies on software to synchronize accesses to its device with every other driver in the system; then a device cross dependency is created and the platform is prone to Device A failure.

4.7 ACPI Hardware Features

This section describes the different hardware features defined by the ACPI interface. These features are categorized as the following:

- Fixed Hardware Features
- Generic Hardware Features

Fixed hardware features reside in a number of the ACPI-defined address spaces at the locations described by the ACPI programming model. Generic hardware features reside in one of four address spaces (system I/O, system memory, PCI configuration, embedded controller, or serial device I/O space) and are described by the ACPI Namespace through the declaration of AML control methods.

Fixed hardware features have exact definitions for their implementation. Although many fixed hardware features are optional, if implemented they must be implemented as described since OSPM manipulates the registers of fixed hardware devices and expects the defined behavior. Functional fixed hardware provides functional equivalents of the fixed hardware feature interfaces as described in *Generic Hardware Programming Model*

Generic hardware feature implementation is flexible. This logic is controlled by OEM-supplied AML code (for more information, see *ACPI Software Programming Model*), which can be written to support a wide variety of hardware. Also, ACPI provides specialized control methods that provide capabilities for specialized devices. For example, the Notify command can be used to notify OSPM from a generic hardware event handler (control method) that a docking or thermal event has taken place. A good understanding of this section and *ACPI Software Programming Model* of

this specification will give designers a good understanding of how to design hardware to take full advantage of an ACPI-compatible OS.

Notice that the generic features are listed for illustration only, the ACPI specification can support many types of hardware not listed.

Table 4.1: Feature-Programming Model Summary

Feature Name	Description	Programming Model
Power Management Timer	24-bit or 32-bit free running timer.	Fixed Hardware Feature Control Logic
Power Button	User pushes button to switch the system between the working and sleeping/soft-off states.	Fixed Hardware Event and Control Logic or Generic Hardware Event and Logic
Sleep Button	User pushes button to switch the system between the working and sleeping/soft-off states.	Fixed Hardware Event and Control Logic or Generic Hardware Event and Logic
Power Button Override	User sequence (press the power button for at least 4 seconds) to turn off a hung system.	
Real Time Clock Alarm	Programmed time to wake the system.	Optional Fixed Hardware*
Sleep/Wake Control Logic	Logic used to transition the system between the sleeping and working states.	Fixed Hardware Control and Event Logic
Embedded Controller Interface	ACPI Embedded Controller protocol and interface, as described in the <i>ACPI Embedded Controller Interface Specification</i> .	Generic Hardware Event Logic, must reside in the general-purpose register block
Legacy/ACPI Select	Status bit that indicates the system is using the legacy or ACPI power management model (SCI_EN).	Fixed Hardware Control Logic
Lid switch	Button used to indicate whether the system's lid is open or closed (mobile systems only)	Generic Hardware Event Feature
C1 Power State	Processor instruction to place the processor into a low-power state.	Processor ISA
C2 Power Control	Logic to place the processor into a C2 power state.	Fixed Hardware Control Logic
C3 Power Control	Logic to place the processor into a C3 power state.	Fixed Hardware Control Logic
Thermal Control	Logic to generate thermal events at specified trip points.	Generic Hardware Event and Control Logic (See description of thermal logic in <i>Thermal Management Concepts</i>)
Device Power Management	Control logic for switching between different device power states.	Generic Hardware control logic
AC Adapter	Logic to detect the insertion and removal of the AC adapter.	Generic Hardware event logic
Docking/device insertion and removal	Logic to detect device insertion and removal events.	Generic Hardware event logic

* RTC wakeup alarm is required; the fixed hardware feature status bit is optional.

4.8 ACPI Register Model

ACPI hardware resides in one of six address spaces:

- System I/O
- System memory
- PCI configuration
- SMBus
- Embedded controller
- Functional Fixed Hardware

Different implementations will result in different address spaces being used for different functions. The ACPI specification consists of fixed hardware registers and generic hardware registers. Fixed hardware registers are required to implement ACPI-defined interfaces. The generic hardware registers are needed for any events generated by value-added hardware.

ACPI defines register blocks. An ACPI-compatible system provides an ACPI table (the FADT, built in memory at boot-up) that contains a list of pointers to the different fixed hardware register blocks used by OSPM. The bits within these registers have attributes defined for the given register block. The types of registers that ACPI defines are:

- Status/Enable Registers (for events)
- Control Registers

If a register block is of the status/enable type, then it will contain a register with status bits, and a corresponding register with enable bits. The status and enable bits have an exact implementation definition that needs to be followed (unless otherwise noted), which is illustrated by the following diagram:

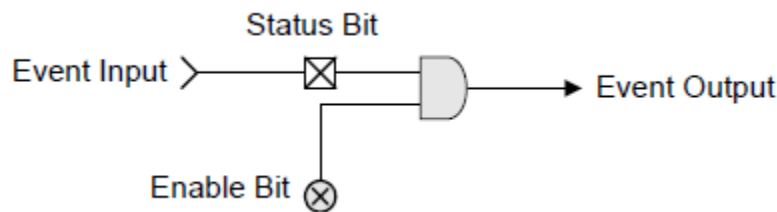

Fig. 4.4: Block Diagram of a Status/Enable Cell

Notice that the status bit, which hardware sets by the Event Input being set in this example, can only be cleared by software writing a 1 to its bit position. Also, the enable bit has no effect on the setting or resetting of the status bit; it only determines if the SET status bit will generate an “Event Output,” which generates an SCI when set if its enable bit is set.

ACPI also defines register groupings. A register grouping consists of two register blocks, with two pointers to two different blocks of registers, where each bit location within a register grouping is fixed and cannot be changed. The bits within a register grouping, which have fixed bit positions, can be split between the two register blocks. This allows the bits within a register grouping to reside in either or both register blocks, facilitating the ability to map bits within several different chips to the same register thus providing the programming model with a single register grouping bit structure.

OSPM treats a register grouping as a single register; but located in multiple places. To read a register grouping, OSPM will read the “A” register block, followed by the “B” register block, and then will logically “OR” the two results together (the SLP_TYP field is an exception to this rule). Reserved bits, or unused bits within a register block always return zero for reads and have no side effects for writes (which is a requirement).

The SLP_TYPx field can be different for each register grouping. The respective sleeping object _Sx contains a SLP_TYPa and a SLP_TYPb field. That is, the object returns a package with two integer values of 0-7 in it. OSPM will always write the SLP_TYPa value to the “A” register block followed by the SLP_TYPb value within the field to the “B” register block. All other bit locations will be written with the same value. Also, OSPM does not read the SLP_TYPx value but throws it away.

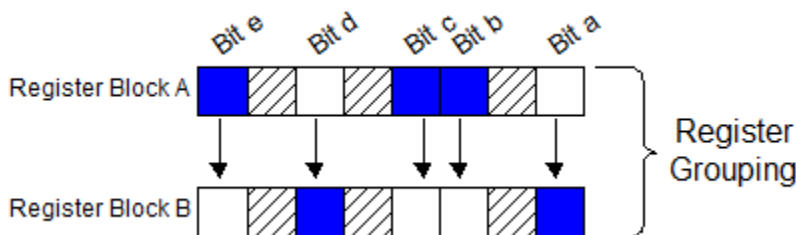

Fig. 4.5: Example Fixed Hardware Feature Register Grouping

As an example, the above diagram represents a register grouping consisting of register block A and register block B. Bits “a” and “d” are implemented in register block B and register block A returns a zero for these bit positions. Bits “b”, “c” and “e” are implemented in register block A and register block B returns a zero for these bit positions. All reserved or ignored bits return their defined ACPI values.

When accessing this register grouping, OSPM must read register block a, followed by reading register block b. OSPM then does a logical OR of the two registers and then operates on the results.

When writing to this register grouping, OSPM will write the desired value to register group A followed by writing the same value to register group B.

ACPI defines the following fixed hardware register blocks. Each register block gets a separate pointer from the FADT. These addresses are set by the OEM as static resources, so they are never changed—OSPM cannot re-map ACPI resources. The following register blocks are defined:

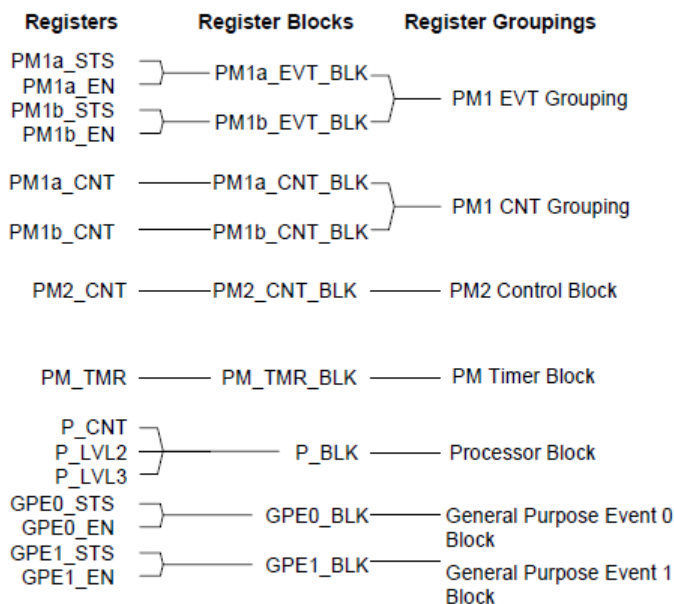

Fig. 4.6: Register Blocks versus Register Groupings

The PM1 EVT grouping consists of the PM1a_EVT and PM1b_EVT register blocks, which contain the fixed hardware feature event bits. Each event register block (if implemented) contains two registers: a status register and an enable

register. Each register grouping has a defined bit position that cannot be changed; however, the bit can be implemented in either register block (A or B). The A and B register blocks for the events allow chipsets to vary the partitioning of events into two or more chips. For read operations, OSPM will generate a read to the associated A and B registers, OR the two values together, and then operate on this result. For write operations, OSPM will write the value to the associated register in both register blocks. Therefore, there are two rules to follow when implementing event registers:

- Reserved or unimplemented bits always return zero (control or enable).
- Writes to reserved or unimplemented bits have no affect.

The PM1 CNT grouping contains the fixed hardware feature control bits and consists of the PM1a_CNT_BLK and PM1b_CNT_BLK register blocks. Each register block is associated with a single control register. Each register grouping has a defined bit position that cannot be changed; however, the bit can be implemented in either register block (A or B). There are two rules to follow when implementing CNT registers:

- Reserved or unimplemented bits always return zero (control or enable).
- Writes to reserved or unimplemented bits have no affect.

The PM2_CNT_BLK register block currently contains a single bit for the arbiter disable function. The general-purpose event register contains the event programming model for generic features. All generic events, just as fixed events, generate SCIs. Generic event status bits can reside anywhere; however, the top-level generic event resides in one of the general-purpose register blocks. Any generic feature event status not in the general-purpose register space is considered a child or sibling status bit, whose parent status bit is in the general-purpose event register space. Notice that it is possible to have N levels of general-purpose events prior to hitting the GPE event status.

General-purpose event registers are described by two register blocks: The GPE0_BLK or the GPE1_BLK. Each register block is pointed to separately from within the FADT. Each register block is further broken into two registers: GPEx_STS and GPEx_EN. The status and enable registers in the general-purpose event registers follow the event model for the fixed hardware event registers.

4.8.1 ACPI Register Summary

The following tables summarize the ACPI registers:

Table 4.2: PM1 Event Registers

Register	Size (Bytes)	Address (relative to register block)
PM1a_STS	PM1_EVT_LEN/2	<PM1a_EVT_BLK>
PM1a_EN	PM1_EVT_LEN/2	<PM1a_EVT_BLK>+PM1_EVT_LEN/2
PM1b_STS	PM1_EVT_LEN/2	<PM1b_EVT_BLK>
PM1b_EN	PM1_EVT_LEN/2	<PM1b_EVT_BLK>+PM1_EVT_LEN/2

Table 4.3: PM1 Control Registers

Register	Size (Bytes)	Address (relative to register block)
PM1_CNTa	PM1_CNT_LEN	<PM1a_CNT_BLK>
PM1_CNTb	PM1_CNT_LEN	<<PM1b_CNT_BLK>

Table 4.4: PM2 Control Register

Register	Size (Bytes)	Address (relative to register block)
PM2_CNT	PM2_CNT_LEN	<PM2_CNT_BLK>

Table 4.5: PM Timer Register

Register	Size (Bytes)	Address (relative to register block)
PM_TMR	PM_TMR_LEN	<PM_TMR_BLK>

Table 4.6: Processor Control Registers

Register	Size (Bytes)	Address (relative to register block)
P_CNT	4	Either <P_BLK> or specified by the PTC object - see <i>Processor Throttling Controls</i>
P_LVL2	1	<P_BLK>+4h
P_LVL3	1	<P_BLK>+5h

Table 4.7: General-Purpose Event Registers

Register	Size (Bytes)	Address (relative to register block)
GPE0_STS	GPE0_LEN/2	<GPE0_BLK>
GPE0_EN	GPE0_LEN/2	<GPE0_BLK>+GPE0_LEN/2
GPE1_STS	GPE1_LEN/2	<GPE1_BLK>
GPE1_EN	GPE1_LEN/2	<GPE1_BLK>+GPE1_LEN/2

4.8.1.1 PM1 Event Registers

The PM1 event register grouping contains two register blocks: the PM1a_EVT_BLK is a required register block when the following ACPI interface categories are required by a class specific platform design guide:

- Power management timer control/status
- Processor power state control/status
- Global Lock related interfaces
- Power or Sleep button (fixed register interfaces)
- System power state controls (sleeping/wake control)

The PM1b_EVT_BLK is an optional register block. Each register block has a unique 32-bit pointer in the Fixed ACPI Table (FADT) to allow the PM1 event bits to be partitioned between two chips. If the PM1b_EVT_BLK is not supported, its pointer contains a value of zero in the FADT.

Each register block in the PM1 event grouping contains two registers that are required to be the same size: the PM1x_STS and PM1x_EN (where x can be “a” or “b”). The length of the registers is variable and is described by the PM1_EVT_LEN field in the FADT, which indicates the total length of the register block in bytes. Hence if a length of “4” is given, this indicates that each register contains two bytes of I/O space. The PM1 event register block has a minimum size of 4 bytes.

4.8.1.2 PM1 Control Registers

The PM1 control register grouping contains two register blocks: the PM1a_CNT_BLK is a required register block when the following ACPI interface categories are required by a class specific platform design guide:

- SCI/SMI routing control/status for power management and general-purpose events
- Processor power state control/status
- Global Lock related interfaces
- System power state controls (sleeping/wake control)

The PM1b_CNT_BLK is an optional register block. Each register block has a unique 32-bit pointer in the Fixed ACPI Table (FADT) to allow the PM1 event bits to be partitioned between two chips. If the PM1b_CNT_BLK is not supported, its pointer contains a value of zero in the FADT.

Each register block in the PM1 control grouping contains a single register: the PM1x_CNT. The length of the register is variable and is described by the PM1_CNT_LEN field in the FADT, which indicates the total length of the register block in bytes. The PM1 control register block must have a minimum size of 2 bytes.

4.8.1.3 PM2 Control Register

The PM2 control register is contained in the PM2_CNT_BLK register block. The FADT contains a length variable for this register block (PM2_CNT_LEN) that is equal to the size in bytes of the PM2_CNT register (the only register in this register block). This register block is optional, if not supported its block pointer and length contain a value of zero.

4.8.1.4 PM Timer Register

The PM timer register is contained in the PM_TMR_BLK register block. It is an optional register block that must be implemented when the power management timer control/status ACPI interface category is required by a class specific platform design guide.

If defined, this register block contains the register that returns the running value of the power management timer. The FADT also contains a length variable for this register block (PM_TMR_LEN) that is equal to the size in bytes of the PM_TMR register (the only register in this register block).

4.8.1.5 Processor Control Block (P_BLK)

There is an optional processor control register block for each processor in the system. As this is a homogeneous feature, all processors must have the same level of support. The ACPI OS will revert to the lowest common denominator of processor control block support. The processor control block contains the processor control register (P_CNT—a 32-bit performance control configuration register), and the P_LVL2 and P_LVL3 CPU sleep state control registers. The 32-bit P_CNT register controls the behavior of the processor clock logic for that processor, the P_LVL2 register is used to place the CPU into the C2 state, and the P_LVL3 register is used to place the processor into the C3 state.

4.8.1.6 General-Purpose Event Registers

The general-purpose event registers contain the root level events for all generic features. To facilitate the flexibility of partitioning the root events, ACPI provides for two different general-purpose event blocks: GPE0_BLK and GPE1_BLK. These are separate register blocks and are not a register grouping, because there is no need to maintain an orthogonal bit arrangement. Also, each register block contains its own length variable in the FADT, where GPE0_LEN and GPE1_LEN represent the length in bytes of each register block.

Each register block contains two registers of equal length: GPE_x_STS and GPE_x_EN (where x is 0 or 1). The length of the GPE0_STS and GPE0_EN registers is equal to half the GPE0_LEN. The length of the GPE1_STS and GPE1_EN registers is equal to half the GPE1_LEN. If a generic register block is not supported then its respective block pointer and block length values in the FADT table contain zeros. The GPE0_LEN and GPE1_LEN do not need to be the same size.

4.8.2 Fixed Hardware Features

This section describes the fixed hardware features defined by ACPI.

4.8.2.1 Power Management Timer

The ACPI specification defines an optional power management timer that provides an accurate time value that can be used by system software to measure and profile system idleness (along with other tasks). The power management timer provides an accurate time function while the system is in the working (G0) state. To allow software to extend the number of bits in the timer, the power management timer generates an interrupt when the last bit of the timer changes (from 0 to 1 or 1 to 0). ACPI supports either a 24-bit or 32-bit power management timer. The PM Timer is accessed directly by OSPM, and its programming model is contained in fixed register space. The programming model can be partitioned in up to three different register blocks. The event bits are contained in the PM1_EVT register grouping, which has two register blocks, and the timer value can be accessed through the PM_TMR_BLK register block. A block diagram of the power management timer is illustrated in the following figure.

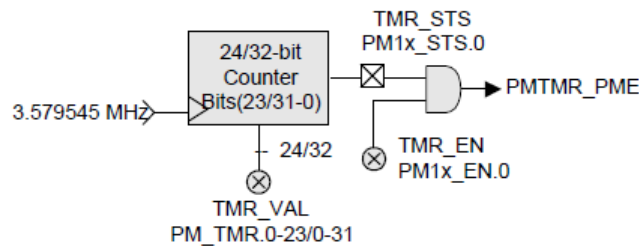

Fig. 4.7: Power Management Timer

The power management timer is a 24-bit or 32-bit fixed rate free running count-up timer that runs off a 3.579545 MHz clock. The ACPI OS checks the FADT to determine whether the PM Timer is a 32-bit or 24-bit timer. The programming model for the PM Timer consists of event logic, and a read port to the counter value. The event logic consists of an event status and enable bit. The status bit is set any time the last bit of the timer (bit 23 or bit 31) goes from set to clear or clear to set. If the TMR_EN bit is set, then the setting of the TMR_STS will generate an ACPI event in the PM1_EVT register grouping (referred to as PMTMR_PME in the diagram). The event logic is only used to emulate a larger timer.

OSPM uses the read-only TMR_VAL field (in the PM TMR register grouping) to read the current value of the timer. OSPM never assumes an initial value of the TMR_VAL field; instead, it reads an initial TMR_VAL upon loading OSPM and assumes that the timer is counting. It is allowable to stop the Timer when the system transitions out of the working (G0/S0) state. The only timer reset requirement is that the timer functions while in the working state.

The PM Timer’s programming model is implemented as a fixed hardware feature to increase the accuracy of reading the timer.

4.8.2.2 Console Buttons

ACPI defines user-initiated events to request OSPM to transition the platform between the G0 working state and the G1 sleeping, G2 soft off and G3 mechanical off states. ACPI also defines a recommended mechanism to unconditionally transition the platform from a hung G0 working state to the G2 soft-off state.

ACPI operating systems use power button events to determine when the user is present. As such, these ACPI events are associated with buttons in the ACPI specification.

The ACPI specification supports two button models:

- A single-button model that generates an event for both sleeping and entering the soft-off state. The function of the button can be configured using OSPM UI.
- A dual-button model where the power button generates a soft-off transition request and a sleep button generates a sleep transition request. The type of button implies the function of the button.

Control of these button events is either through the fixed hardware programming model or the generic hardware programming model (control method based). The fixed hardware programming model has the advantage that OSPM can access the button at any time, including when the system is crashed. In a crashed system with a fixed hardware power button, OSPM can make a “best” effort to determine whether the power button has been pressed to transition to the system to the soft-off state, because it doesn’t require the AML interpreter to access the event bits.

4.8.2.2.1 Power Button

The power button logic can be used in one of two models: single button or dual button. In the single-button model, the user button acts as both a power button for transitioning the system between the G0 and G2 states and a sleep button for transitioning the system between the G0 and G1 states. The action of the user pressing the button is determined by software policy or user settings. In the dual-button model, there are separate buttons for sleeping and power control. Although the buttons still generate events that cause software to take an action, the function of the button is now dedicated: the sleep button generates a sleep request to OSPM and the power button generates a wake request.

Support for a power button is indicated by a combination of the PWR_BUTTON flag and the power button device object, as shown in the following:

Table 4.8: Power Button Support

Indicated Support	PWR_BUTTON Flag	Power Button Device Object
Fixed hardware power button	Clear	Absent
Control method power button	Set	Present

The power button can also have an additional capability to unconditionally transition the system from a hung working state to the G2 soft-off state. In the case where OSPM event handler is no longer able to respond to power button events, the power button override feature provides a back-up mechanism to unconditionally transition the system to the soft-off state. This feature can be used when the platform doesn’t have a mechanical off button, which can also provide this function. ACPI defines that holding the power button active for four seconds or longer will generate a power button override event.

4.8.2.2.1.1 Fixed Power Button



Fig. 4.8: Fixed Power Button Logic

The fixed hardware power button has its event programming model in the `PM1x_EVT_BLK`. This logic consists of a single enable bit and sticky status bit. When the user presses the power button, the power button status bit (`PWRBTN_STS`) is unconditionally set. If the power button enable bit (`PWRBTN_EN`) is set and the power button status bit is set (`PWRBTN_STS`) due to a button press while the system is in the `G0` state, then an SCI is generated. OSPM responds to the event by clearing the `PWRBTN_STS` bit. The power button logic provides debounce logic that sets the `PWRBTN_STS` bit on the button press “edge.”

While the system is in the `G1` or `G2` global states (`S1`, `S2`, `S3`, `S4` or `S5` states), any further power button press after the button press that transitioned the system into the sleeping state unconditionally sets the power button status bit and wakes the system, regardless of the value of the power button enable bit. OSPM responds by clearing the power button status bit and waking the system.

4.8.2.2.1.2 Control Method Power Button

The power button programming model can also use the generic hardware programming model. This allows the power button to reside in any of the generic hardware address spaces (for example, the embedded controller) instead of fixed space. If the power button is implemented using generic hardware, then the OEM needs to define the power button as a device with an `_HID` object value of “`PNP0C0C`,” which then identifies this device as the power button to OSPM. The AML event handler then generates a `Notify` command to notify OSPM that a power button event was generated. While the system is in the working state, a power button press is a user request to transition the system into either the sleeping (`G1`) or soft-off state (`G2`). In these cases, the power button event handler issues the `Notify` command with the device specific code of `0x80`. This indicates to OSPM to pass control to the power button driver (`PNP0C0C`) with the knowledge that a transition out of the `G0` state is being requested. Upon waking from a `G1` sleeping state, the AML event handler generates a `notify` command with the code of `0x2` to indicate it was responsible for waking the system.

The power button device needs to be declared as a device within the ACPI Namespace for the platform and only requires an `_HID`. An example definition follows.

This example ASL code performs the following:

- Creates a device named “`PWRB`” and associates the Plug and Play identifier (through the `_HID` object) of “`PNP0C0C`.”
- The Plug and Play identifier associates this device object with the power button driver.
- Creates an operational region for the control method power button’s programming model: System I/O space at `0x200`.
- Fields that are not accessed are written as zeros. These status bits clear upon writing a 1 to their bit position, therefore preserved would fail in this case.
- Creates a field within the operational region for the power button status bit (called `PBP`). In this case the power button status bit is a child of the general-purpose event status bit 0. When this bit is set, it is the responsibility of the ASL-code to clear it (OSPM clears the general-purpose status bits). The address of the status bit is `0x200.0` (bit 0 at address `0x200`).

- Creates an additional status bit called PBW for the power button wake event. This is the next bit and its physical address would be 0x200.1 (bit 1 at address 0x200).
- Generates an event handler for the power button that is connected to bit 0 of the general-purpose event status register 0. The event handler does the following:
- Clears the power button status bit in hardware (writes a one to it).
- Notifies OSPM of the event by calling the Notify command passing the power button object and the device specific event indicator 0x80.

```
// Define a control method power button
Device(\_SB.PWRB)
{
    Name(_HID, EISAID("PNP0C0C"))
    Name(_PRW, Package(){0, 0x4})
    OperationRegion(\PHO, SystemIO, 0x200, 0x1)
    Field(\PHO, ByteAcc, NoLock, WriteAsZeros)
    {
        PBP, 1,                // sleep/off request
        PBW, 1                // wakeup request
    }
}

Scope(\_GPE)                // Root level event handlers
{
    Method(_L00)
    {
        // uses bit 0 of GP0_STS register
        If (PBP)
        {
            PBP = One        // clear power button status
            Notify(\_SB.PWRB, 0x80) // Notify OS of event
        }

        If (\PBW)
        {
            PBW = One
            Notify(\_SB.PWRB, 0x2)
        }
    }
}
}
```

4.8.2.2.1.3 Power Button Override

The ACPI specification also allows that if the user presses the power button for more than four seconds while the system is in the working state, a hardware event is generated and the system will transition to the soft-off state. This hardware event is called a power button override. In reaction to the power button override event, the hardware clears the power button status bit (PWRBTN_STS).

4.8.2.2.2 Sleep Button

When using the two button model, ACPI supports a second button that when pressed will request OSPM to transition the platform between the G0 working and G1 sleeping states. Support for a sleep button is indicated by a combination of the SLEEP_BUTTON flag and the sleep button device object:

Table 4.9: Sleep Button Support

Indicated Support	SLEEP_BUTTON Flag	Sleep Button Device Object
No sleep button	Set	Absent
Fixed hardware sleep button	Clear	Absent
Control method sleep button	Set	Present

4.8.2.2.2.1 Fixed Hardware Sleep Button

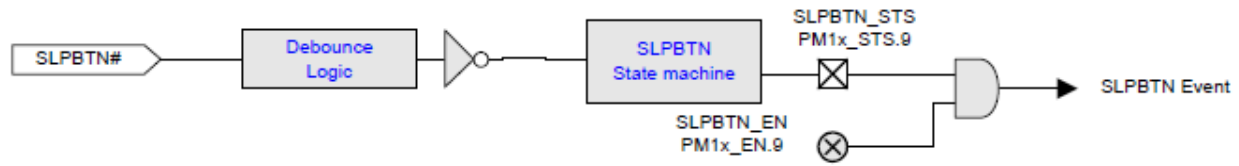

Fig. 4.9: Fixed Hardware Sleep Button Logic

The fixed hardware sleep button has its event programming model in the PM1x_EVT_BLK. This logic consists of a single enable bit and sticky status bit. When the user presses the sleep button, the sleep button status bit (SLPBTN_STS) is unconditionally set. Additionally, if the sleep button enable bit (SLPBTN_EN) is set, and the sleep button status bit is set (SLPBTN_STS, due to a button press) while the system is in the G0 state, then an SCI is generated. OSPM responds to the event by clearing the SLPBTN_STS bit. The sleep button logic provides debounce logic that sets the SLPBTN_STS bit on the button press “edge.”

While the system is sleeping (in either the S0, S1, S2, S3 or S4 states), any further sleep button press (after the button press that caused the system transition into the sleeping state) sets the sleep button status bit (SLPBTN_STS) and wakes the system if the SLP_EN bit is set. OSPM responds by clearing the sleep button status bit and waking the system.

4.8.2.2.2.2 Control Method Sleep Button

The sleep button programming model can also use the generic hardware programming model. This allows the sleep button to reside in any of the generic hardware address spaces (for example, the embedded controller) instead of fixed space. If the sleep button is implemented via generic hardware, then the OEM needs to define the sleep button as a device with an _HID object value of “PNP0C0E”, which then identifies this device as the sleep button to OSPM. The AML event handler then generates a Notify command to notify OSPM that a sleep button event was generated. While in the working state, a sleep button press is a user request to transition the system into the sleeping (G1) state. In these cases the sleep button event handler issues the Notify command with the device specific code of 0x80. This will indicate to OSPM to pass control to the sleep button driver (PNP0C0E) with the knowledge that the user is requesting a transition out of the G0 state. Upon waking-up from a G1 sleeping state, the AML event handler generates a Notify command with the code of 0x2 to indicate it was responsible for waking the system.

The sleep button device needs to be declared as a device within the ACPI Namespace for the platform and only requires an _HID. An example definition is shown below.

The AML code below does the following:

- Creates a device named “SLPB” and associates the Plug and Play identifier (through the `_HID` object) of “PNP0C0E.”
- The Plug and Play identifier associates this device object with the sleep button driver.
- Creates an operational region for the control method sleep button’s programming model: System I/O space at 0x201.
- Fields that are not accessed are written as “1s” (these status bits clear upon writing a “1” to their bit position, hence preserved would fail in this case).
- Creates a field within the operational region for the sleep button status bit (called PBP). In this case the sleep button status bit is a child of the general-purpose status bit 0. When this bit is set it is the responsibility of the AML code to clear it (OSPM clears the general-purpose status bits). The address of the status bit is 0x201.0 (bit 0 at address 0x201).
- Creates an additional status bit called PBW for the sleep button wake event. This is the next bit and its physical address would be 0x201.1 (bit 1 at address 0x201).
- Generates an event handler for the sleep button that is connected to bit 0 of the general-purpose status register 0. The event handler does the following:
 - Clears the sleep button status bit in hardware (writes a “1” to it).
 - Notifies OSPM of the event by calling the Notify command passing the sleep button object and the device specific event indicator 0x80.

```
// Define a control method sleep button
Device (\_SB.SLPB)
{
    Name (_HID, EISAID("PNP0C0E"))
    Name (_PRW, Package(){0x01, 0x04})
    OperationRegion (\Boo, SystemIO, 0x201, 0x1)
    Field (\Boo, ByteAcc, NoLock, WriteAsZeros)
    {
        SBP, 1,                // sleep request
        SBW, 1                // wakeup request
    }
}

Scope (\_GPE)                // Root level event handlers
{
    Method (_L01)             // uses bit 1 of GP0_STS register
    {
        If (\SBP)
        {
            \SBP = One        // clear sleep button status
            Notify(\_SB.SLPB, 0x80) // Notify OS of event
        }
        If (\SBW)
        {
            \SBW = One
            Notify(\_SB.SLPB, 0x2)
        }
    }
}
```

4.8.2.3 Sleeping/Wake Control

The sleeping/wake logic consists of logic that will sequence the system into the defined low-power hardware sleeping state (S1-S4) or soft-off state (S5) and will wake the system back to the working state upon a wake event. Notice that the S4BIOS state is entered in a different manner (for more information, see *The S4BIOS Transition*).

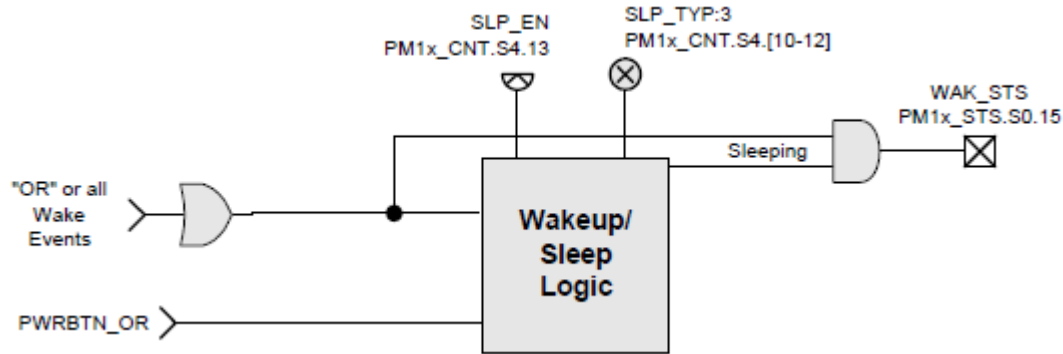

Fig. 4.10: Sleeping/Wake Logic

The logic is controlled via two bit fields: Sleep Enable (SLP_EN) and Sleep Type (SLP_TYPx). The type of sleep or soft-off state desired is programmed into the SLP_TYPx field and upon assertion of the SLP_EN the hardware will sequence the system into the defined sleeping state. OSPM gets values for the SLP_TYPx field from the \backslash_Sx objects defined in the static definition block. If the object is missing OSPM assumes the hardware does not support that sleeping state. Prior to entering the desired sleeping state, OSPM will read the designated \backslash_Sx object and place this value in the SLP_TYP field.

Additionally ACPI defines a fail-safe Off protocol called the “power button override,” which allows the user to initiate an Off sequence in the case where the system software is no longer able to recover the system (the system has hung). ACPI defines that this sequence be initiated by the user pressing the power button for over 4 seconds, at which point the hardware unconditionally sequences the system to the Off state. This logic is represented by the PWRBTN_OR signal coming into the sleep logic.

While in any of the sleeping states (G1), an enabled “Wake” event will cause the hardware to sequence the system back to the working state (G0). The “Wake Status” bit (WAK_STS) is provided for OSPM to “spin-on” after setting the SLP_EN/SLP_TYP bit fields. When waking from the S1 sleeping state, execution control is passed backed to OSPM immediately, whereas when waking from the S2-S4 states execution control is passed to the platform boot firmware (execution begins at the CPU’s reset vector). The WAK_STS bit provides a mechanism to separate OSPM’s sleeping and waking code during an S1 sequence. When the hardware has sequenced the system into the sleeping state (defined here as the processor is no longer able to execute instructions), any enabled wake event is allowed to set the WAK_STS bit and sequence the system back on (to the G0 state). If the system does not support the S1 sleeping state, the WAK_STS bit can always return zero.

If more than a single sleeping state is supported, then the sleeping/wake logic is required to be able to dynamically sequence between the different sleeping states. This is accomplished by waking the system; OSPM programs the new sleep state into the SLP_TYP field, and then sets the SLP_EN bit—placing the system again in the sleeping state.

4.8.2.4 Real Time Clock Alarm

If implemented, the Real Time Clock (RTC) alarm must generate a hardware wake event when in the sleeping state. The RTC can be programmed to generate an alarm. An enabled RTC alarm can be used to generate a wake event when the system is in a sleeping state. ACPI provides for additional hardware to support OSPM in determining that the RTC was the source of the wake event: the RTC_STS and RTC_EN bits. Although these bits are optional, if supported they must be implemented as described here.

If the RTC_STS and RTC_EN bits are not supported, OSPM will attempt to identify the RTC as a possible wake source; however, it might miss certain wake events. If implemented, the RTC wake feature is required to work in the following sleeping states: S1-S3. S4 wake is optional and supported through the RTC_S4 flag within the FADT (if set, then the platform supports RTC wake in the S4 state) *.

Note: * The G2/S5 “soft off” and the G3 “mechanical off” states are not sleeping states. The OS will disable the RTC_EN bit prior to entering the G2/S5 or G3 states regardless.

When the RTC generates a wake event the RTC_STS bit will be set. If the RTC_EN bit is set, an RTC hardware power management event will be generated (which will wake the system from a sleeping state, provided the battery low signal is not asserted).

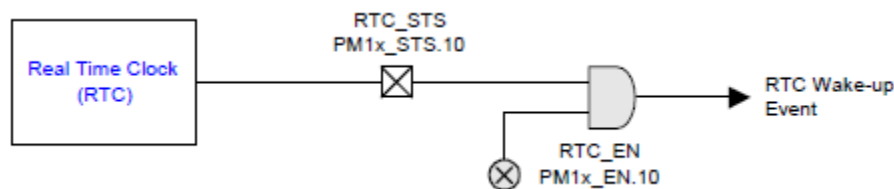

Fig. 4.11: RTC Alarm

The RTC wake event status and enable bits are an optional fixed hardware feature and a flag within the FADT (FIX_RTC) indicates if the register bits are to be used by OSPM. If the RTC wake event status and enable bits are implemented in fixed hardware, OSPM can determine if the RTC was the source of the wake event without loading the entire OS. This also gives the platform the capability of indicating an RTC wake source without consuming a GPE bit, as would be required if RTC wake was not implemented using the fixed hardware RTC feature. If the fixed hardware feature event bits are not supported, then OSPM will attempt to determine this by reading the RTC’s status field. If the platform implements the RTC fixed hardware feature, and this hardware consumes resources, the _FIX method can be used to correlate these resources with the fixed hardware. See *_FIX (Fixed Register Resource Provider)*, for details.

OSPM supports enhancements over the existing RTC device (which only supports a 99 year date and 24-hour alarm). Optional extensions are provided for the following features:

Day Alarm The DAY_ALRM field points to an optional CMOS RAM location that selects the day within the month to generate an RTC alarm.

Month Alarm The MON_ALRM field points to an optional CMOS RAM location that selects the month within the year to generate an RTC alarm.

Centenary Value The CENT field points to an optional CMOS RAM location that represents the centenary value of the date (thousands and hundreds of years).

The RTC_STS bit may be set through the RTC interrupt (IRQ8 in IA-PC architecture systems). OSPM will insure that the periodic and update interrupt sources are disabled prior to sleeping. This allows the RTC’s interrupt pin to serve as the source for the RTC_STS bit generation. Note however that if the RTC interrupt pin is used for RTC_STS generation, the RTC_STS bit value may not be accurate when waking from S4. If this value is accurate when waking from S4, the platform should set the S4_RTC_STS_VALID flag, so that OSPM can utilize the RTC_STS information.

Table 4.10: Alarm Field Decodings within the FADT

Field	Value	Address (Location) in RTC CMOS RAM (Must be Bank 0)
DAY_ALARM	Eight bit value that can represent 0x01-0x31 days in BCD or 0x01-0x1F days in binary. Bits 6 and 7 of this field are treated as Ignored by software. The RTC is initialized such that this field contains a “don’t care” value when the platform firmware switches from legacy to ACPI mode. A don’t care value can be any unused value (not 0x1-0x31 BCD or 0x01-0x1F hex) that the RTC reverts back to a 24 hour alarm.	The DAY_ALARM field in the FADT will contain a non-zero value that represents an offset into the RTC’s CMOS RAM area that contains the day alarm value. A value of zero in the DAY_ALARM field indicates that the day alarm feature is not supported.
MON_ALARM	Eight bit value that can represent 01-12 months in BCD or 0x01-0xC months in binary. The RTC is initialized such that this field contains a don’t care value when the platform firmware switches from legacy to ACPI mode. A “don’t care” value can be any unused value (not 1-12 BCD or x01-xC hex) that the RTC reverts back to a 24 hour alarm and/or 31 day alarm).	The MON_ALARM field in the FADT will contain a non-zero value that represents an offset into the RTC’s CMOS RAM area that contains the month alarm value. A value of zero in the MON_ALARM field indicates that the month alarm feature is not supported. If the month alarm is supported, the day alarm function must also be supported.
CENTURY	8-bit BCD or binary value. This value indicates the thousand year and hundred year (Centenary) variables of the date in BCD (19 for this century, 20 for the next) or binary (x13 for this century, x14 for the next).	The CENTURY field in the FADT will contain a non-zero value that represents an offset into the RTC’s CMOS RAM area that contains the Centenary value for the date. A value of zero in the CENTURY field indicates that the Centenary value is not supported by this RTC.

4.8.2.5 Legacy/ACPI Select and the SCI Interrupt

As mentioned previously, power management events are generated to initiate an interrupt or hardware sequence. ACPI operating systems use the SCI interrupt handler to respond to events, while legacy systems use some type of transparent interrupt handler to respond to these events (that is, an SMI interrupt handler). ACPI-compatible hardware can choose to support both legacy and ACPI modes or just an ACPI mode. Legacy hardware is needed to support these features for non-ACPI-compatible operating systems. When the ACPI OS loads, it scans the platform firmware tables to determine that the hardware supports ACPI, and then if it finds the SCI_EN bit reset (indicating that ACPI is not enabled), issues an ACPI activate command to the SMI handler through the SMI command port. The platform firmware acknowledges the switching to the ACPI model of power management by setting the SCI_EN bit (this bit can also be used to switch over the event mechanism as illustrated below):

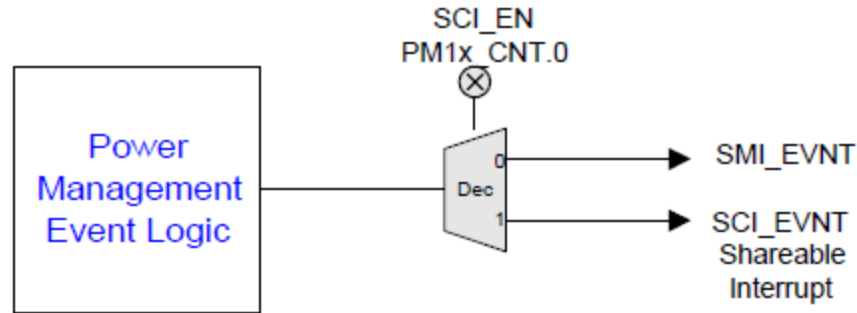

Fig. 4.12: Power Management Events to SMI/SCI Control Logic

The interrupt events (those that generate SMIs in legacy mode and SCIs in ACPI mode) are sent through a decoder controlled by the SCI_EN bit. For legacy mode this bit is reset, which routes the interrupt events to the SMI interrupt logic. For ACPI mode this bit is set, which routes interrupt events to the SCI interrupt logic. This bit always returns set for ACPI-compatible hardware that does not support a legacy power management mode (in other words, the bit is wired to read as “1” and ignore writes).

The SCI interrupt is defined to be a shareable interrupt and is connected to an OS visible interrupt that uses a shareable protocol. The FADT has an entry that indicates what interrupt the SCI interrupt is mapped to (see *System Description Table Header*).

If the ACPI platform supports both legacy and ACPI modes, it has a register that generates a hardware event (for example, SMI for IA-PC processors). OSPM uses this register to make the hardware switch in and out of ACPI mode. Within the FADT are three values that signify the address (SMI_CMD) of this port and the data value written to enable the ACPI state (ACPI_ENABLE), and to disable the ACPI state (ACPI_DISABLE).

To transition an ACPI/Legacy platform from the Legacy mode to the ACPI mode the following would occur:

- ACPI driver checks that the SCI_EN bit is zero, and that it is in the Legacy mode.
- OSPM does an OUT to the SMI_CMD port with the data in the ACPI_ENABLE field of the FADT.
- OSPM polls the SCI_EN bit until it is sampled as SET.

To transition an ACPI/Legacy platform from the ACPI mode to the Legacy mode the following would occur:

- ACPI driver checks that the SCI_EN bit is one, and that it is in the ACPI mode.
- OSPM does an OUT to the SMI_CMD port with the data in the ACPI_DISABLE field of the FADT.
- OSPM polls the SCI_EN bit until it is sampled as RESET.

Platforms that only support ACPI always return a 1 for the SCI_EN bit. In this case OSPM skips the Legacy to ACPI transition stated above.

4.8.2.6 Processor Control

The ACPI specification defines several processor controls including power state control, throttling control, and performance state control. See *Processor Configuration and Control* for a complete description of the processor controls.

4.8.3 Fixed Hardware Registers

The fixed hardware registers are manipulated directly by OSPM. The following sections describe fixed hardware features under the programming model. OSPM owns all the fixed hardware resource registers; these registers cannot be manipulated by AML code. Registers are accessed with any width up to its register width (byte granular).

4.8.3.1 PM1 Event Grouping

The PM1 Event Grouping has a set of bits that can be distributed between two different register blocks. This allows these registers to be partitioned between two chips, or all placed in a single chip. Although the bits can be split between the two register blocks (each register block has a unique pointer within the FADT), the bit positions are maintained. The register block with unimplemented bits (that is, those implemented in the other register block) always returns zeros, and writes have no side effects.

4.8.3.1.1 PM1 Status Registers

Register Location: <PM1a_EVT_BLK / PM1b_EVT_BLK> System I/O or Memory Space

Default Value: 00h

Attribute: Read/Write

Size: PM1_EVT_LEN / 2

The PM1 status registers contain the fixed hardware feature status bits. The bits can be split between two registers: PM1a_STS or PM1b_STS. Each register grouping can be at a different 32-bit aligned address and is pointed to by the PM1a_EVT_BLK or PM1b_EVT_BLK. The values for these pointers to the register space are found in the FADT. Accesses to the PM1 status registers are done through byte or word accesses.

For ACPI/legacy systems, when transitioning from the legacy to the G0 working state this register is cleared by platform firmware prior to setting the SCI_EN bit (and thus passing control to OSPM). For ACPI only platforms (where SCI_EN is always set), when transitioning from either the mechanical off (G3) or soft-off state to the G0 working state this register is cleared prior to entering the G0 working state.

This register contains optional features enabled or disabled within the FADT. If the FADT indicates that the feature is not supported as a fixed hardware feature, then software treats these bits as ignored.

Table 4.11: **PM1 Status Registers Fixed Hardware Feature Status Bits**

Bit	Name	Description
0	TMR_STS	This is the timer carry status bit. This bit gets set any time the most significant bit of a 24/32-bit counter changes from clear to set or set to clear. While TMR_EN and TMR_STS are set, an interrupt event is raised.
1-3	<i>Reserved</i>	Reserved
4	BM_STS	This is the bus master status bit. This bit is set any time a system bus master requests the system bus, and can only be cleared by writing a “1” to this bit position. Notice that this bit reflects bus master activity, not CPU activity (this bit monitors any bus master that can cause an incoherent cache for a processor in the C3 state when the bus master performs a memory transaction).

continues on next page

Table 4.11 – continued from previous page

Bit	Name	Description
5	GBL_STS	This bit is set when an SCI is generated due to the platform runtime firmware wanting the attention of the SCI handler. Platform runtime firmware will have a control bit (somewhere within its address space) that will raise an SCI and set this bit. This bit is set in response to the platform runtime firmware releasing control of the Global Lock and having seen the pending bit set.
6-7	<i>Reserved</i>	Reserved. These bits always return a value of zero.
8	PWRBTN_STS	This optional bit is set when the Power Button is pressed. In the system working state, while PWRBTN_EN and PWRBTN_STS are both set, an interrupt event is raised. In the sleep or soft-off state, a wake event is generated when the power button is pressed (regardless of the PWRBTN_EN bit setting). This bit is only set by hardware and can only be reset by software writing a “1” to this bit position. ACPI defines an optional mechanism for unconditional transitioning a system that has stopped working from the G0 working state into the G2 soft-off state called the power button override. If the Power Button is held active for more than four seconds, this bit is cleared by hardware and the system transitions into the G2/S5 Soft Off state (unconditionally). Support for the power button is indicated by the PWR_BUTTON flag in the FADT being reset (zero). If the PWR_BUTTON flag is set or a power button device object is present in the ACPI Namespace, then this bit field is ignored by OSPM. If the power button was the cause of the wake (from an S1-S4 state), then this bit is set prior to returning control to OSPM.
9	SLPBTN_STS	This optional bit is set when the sleep button is pressed. In the system working state, while SLPBTN_EN and SLPBTN_STS are both set, an interrupt event is raised. In the sleep or soft-off states a wake event is generated when the sleeping button is pressed and the SLPBTN_EN bit is set. This bit is only set by hardware and can only be reset by software writing a “1” to this bit position. Support for the sleep button is indicated by the SLP_BUTTON flag in the FADT being reset (zero). If the SLP_BUTTON flag is set or a sleep button device object is present in the ACPI Namespace, then this bit field is ignored by OSPM. If the sleep button was the cause of the wake (from an S1-S4 state), then this bit is set prior to returning control to OSPM.
10	RTC_STS	This optional bit is set when the RTC generates an alarm (asserts the RTC IRQ signal). Additionally, if the RTC_EN bit is set then the setting of the RTC_STS bit will generate a power management event (an SCI, SMI, or resume event). This bit is only set by hardware and can only be reset by software writing a ‘1’ to this bit position. If the RTC was the cause of the wake (from an S1-S3 state), then this bit is set prior to returning control to OSPM. If the RTC_S4 flag within the FADT is set, and the RTC was the cause of the wake from the S4 state), then this bit is set prior to returning control to OSPM.
11	Ignore	This bit field is ignored by software.
12-14	<i>Reserved</i>	Reserved. These bits always return a value of zero.

continues on next page

Table 4.11 – continued from previous page

Bit	Name	Description
14	PCIEXP_WAKE_STS	This bit is optional for chipsets that implement PCI Express. This bit is set by hardware to indicate that the system woke due to a PCI Express wakeup event. A PCI Express wakeup event is defined as the PCI Express WAKE# pin being active, one or more of the PCI Express ports being in the beacon state, or receipt of a PCI Express PME message at a root port. This bit should only be set when one of these events causes the system to transition from a non-S0 system power state to the S0 system power state. This bit is set independent of the state of the PCIEXP_WAKE_DIS bit. Software writes a 1 to clear this bit. If the WAKE# pin is still active during the write, one or more PCI Express ports is in the beacon state or the PME message received indication has not been cleared in the root port, then the bit will remain active (i.e. all inputs to this bit are level-sensitive). Note: This bit does not itself cause a wake event or prevent entry to a sleeping state. Thus if the bit is 1 and the system is put into a sleeping state, the system will not automatically wake.
15	WAK_STS	This bit is set when the system is in the sleeping state and an enabled wake event occurs. Upon setting this bit system will transition to the working state. This bit is set by hardware and can only be cleared by software writing a “1” to this bit position.

4.8.3.1.2 PM1Enable Registers

Register Location: <<PM1a_EVT_BLK / PM1b_EVT_BLK> + PM1_EVT_LEN / 2 System I/O or Memory Space

Default Value: 00h

Attribute: Read/Write

Size: PM1_EVT_LEN / 2

The PM1 enable registers contain the fixed hardware feature enable bits. The bits can be split between two registers: PM1a_EN or PM1b_EN. Each register grouping can be at a different 32-bit aligned address and is pointed to by the PM1a_EVT_BLK or PM1b_EVT_BLK. The values for these pointers to the register space are found in the FADT. Accesses to the PM1 Enable registers are done through byte or word accesses.

For ACPI/legacy systems, when transitioning from the legacy to the G0 working state the enables are cleared by platform firmware prior to setting the SCI_EN bit (and thus passing control to OSPM). For ACPI-only platforms (where SCI_EN is always set), when transitioning from either the mechanical off (G3) or soft-off state to the G0 working state this register is cleared prior to entering the G0 working state.

This register contains optional features enabled or disabled within the FADT. If the FADT indicates that the feature is not supported as a fixed hardware feature, then software treats the enable bits as write as zero.

Table 4.12: PM1 Enable Registers Fixed Hardware Feature Enable Bits

Bit	Name	Description
0	TMR_EN	This is the timer carry interrupt enable bit. When this bit is set then an SCI event is generated anytime the TMR_STS bit is set. When this bit is reset then no interrupt is generated when the TMR_STS bit is set.
1-4	<i>Reserved</i>	Reserved. These bits always return a value of zero.
5	GBL_EN	The global enable bit. When both the GBL_EN bit and the GBL_STS bit are set, an SCI is raised.

continues on next page

Table 4.12 – continued from previous page

Bit	Name	Description
6-7	<i>Reserved</i>	Reserved
8	PWRBTN_EN	This optional bit is used to enable the setting of the PWRBTN_STS bit to generate a power management event (SCI or wake). The PWRBTN_STS bit is set anytime the power button is asserted. The enable bit does not have to be set to enable the setting of the PWRBTN_STS bit by the assertion of the power button (see description of the power button hardware). Support for the power button is indicated by the PWR_BUTTON flag in the FADT being reset (zero). If the PWR_BUTTON flag is set or a power button device object is present in the ACPI Namespace, then this bit field is ignored by OSPM.
9	SLPBTN_EN	This optional bit is used to enable the setting of the SLPBTN_STS bit to generate a power management event (SCI or wake). The SLPBTN_STS bit is set anytime the sleep button is asserted. The enable bit does not have to be set to enable the setting of the SLPBTN_STS bit by the active assertion of the sleep button (see description of the sleep button hardware). Support for the sleep button is indicated by the SLP_BUTTON flag in the FADT being reset (zero). If the SLP_BUTTON flag is set or a sleep button device object is present in the ACPI Namespace, then this bit field is ignored by OSPM.
10	RTC_EN	This optional bit is used to enable the setting of the RTC_STS bit to generate a wake event. The RTC_STS bit is set any time the RTC generates an alarm.
11-13	<i>Reserved</i>	Reserved. These bits always return a value of zero.
14	PCIEXP_WAKE_DIS	This bit is optional for chipsets that implement PCI Express. This bit disables the inputs to the PCIEXP_WAKE_STS bit in the PM1 Status register from waking the system. Modification of this bit has no impact on the value of the PCIEXP_WAKE_STS bit. PCIEXP_WAKE_DIS bit. Software writes a 1 to clear this bit. If the WAKE# pin is still active during the write, one or more PCI Express ports is in the beacon state or the PME message received indication has not been cleared in the root port, then the bit will remain active (i.e. all inputs to this bit are level-sensitive). Note: This bit does not itself cause a wake event or prevent entry to a sleeping state. Thus if the bit is 1 and the system is put into a sleeping state, the system will not automatically wake.
15	<i>Reserved</i>	Reserved. These bits always return a value of zero.

4.8.3.2 PM1 Control Grouping

The PM1 Control Grouping has a set of bits that can be distributed between two different registers. This allows these registers to be partitioned between two chips, or all placed in a single chip. Although the bits can be split between the two register blocks (each register block has a unique pointer within the FADT), the bit positions specified here are maintained. The register block with unimplemented bits (that is, those implemented in the other register block) returns zeros, and writes have no side effects.

4.8.3.2.1 PM1 Control Registers

Register Location: <PM1a_CNT_BLK / PM1b_CNT_BLK> System I/O or Memory Space

Default Value: 00h

Attribute: Read/Write

Size: PM1_CNT_LEN

The PM1 control registers contain the fixed hardware feature control bits. These bits can be split between two registers: PM1a_CNT or PM1b_CNT. Each register grouping can be at a different 32-bit aligned address and is pointed to by the PM1a_CNT_BLK or PM1b_CNT_BLK. The values for these pointers to the register space are found in the FADT. Accesses to PM1 control registers are accessed through byte and word accesses.

This register contains optional features enabled or disabled within the FADT. If the FADT indicates that the feature is not supported as a fixed hardware feature, then software treats these bits as ignored.

Table 4.13: **PM1 Control Registers Fixed Hardware Feature Control Bits**

Bit	Name	Description
0	SCI_EN	Selects the power management event to be either an SCI or SMI interrupt for the following events. When this bit is set, then power management events will generate an SCI interrupt. When this bit is reset power management events will generate an SMI interrupt. It is the responsibility of the hardware to set or reset this bit. OSPM always preserves this bit position.
1	BM_RLD	When set, this bit allows the generation of a bus master request to cause any processor in the C3 state to transition to the C0 state. When this bit is reset, the generation of a bus master request does not affect any processor in the C3 state.
2	GBL_RLS	This write-only bit is used by the ACPI software to raise an event to the platform runtime firmware, that is, generates an SMI to pass execution control to the platform runtime firmware for IA-PC platforms. Platform runtime firmware software has a corresponding enable and status bit to control its ability to receive ACPI events (for example, BIOS_EN and BIOS_STS). The GBL_RLS bit is set by OSPM to indicate a release of the Global Lock and the setting of the pending bit in the FACS memory structure.
8:3	<i>Reserved</i>	Reserved. These bits are reserved by OSPM.
9	Ignore	Software ignores this bit field.
12:10	SLP_TYPx	Defines the type of sleeping or soft-off state the system enters when the SLP_EN bit is set to one. This 3-bit field defines the type of hardware sleep state the system enters when the SLP_EN bit is set. The _Sx object contains 3-bit binary values associated with the respective sleeping state (as described by the object). OSPM takes the two values from the _Sx object and programs each value into the respective SLP_TYPx field.
13	SLP_EN	This is a write-only bit and reads to it always return a zero. Setting this bit causes the system to sequence into the sleeping state associated with the SLP_TYPx fields programmed with the values from the _Sx object.
15:14	<i>Reserved</i>	Reserved. This field always returns zero.

4.8.3.3 Power Management Timer (PM_TMR)

Register Location: <PM_TMR_BLK> System I/O or Memory Space

Default Value: 00h

Attribute: Read-Only

Size: 32 bits

This optional read-only register returns the current value of the power management timer (PM timer) if it is implemented on the platform. The FADT has a flag called TMR_VAL_EXT that an OEM sets to indicate a 32-bit PM timer or reset to indicate a 24-bit PM timer. When the last bit of the timer toggles the TMR_STS bit is set. This register is accessed as 32 bits.

This register contains optional features enabled or disabled within the FADT. If the FADT indicates that the feature is not supported as a fixed hardware feature, then software treats these bits as ignored.

Table 4.14: PM Timer Bits

Bit	Name	Description
TMR_VAL	23:0	This read-only field returns the running count of the power management timer. This is a 24-bit counter that runs off a 3.579545-MHz clock and counts while in the S0 working system state. The starting value of the timer is undefined, thus allowing the timer to be reset (or not) by any transition to the S0 state from any other state. The timer is reset (to any initial value), and then continues counting until the system's 14.31818 MHz clock is stopped upon entering its Sx state. If the clock is restarted without a reset, then the counter will continue counting from where it stopped.
E_TMR_VAL	31:24	This read-only field returns the upper eight bits of a 32-bit power management timer. If the hardware supports a 32-bit timer, then this field will return the upper eight bits; if the hardware supports a 24-bit timer then this field returns all zeros.

4.8.3.4 PM2 Control (PM2_CNT)

Register Location: <PM2_CNT_BLK> System I/O, System Memory, or Functional

Fixed Hardware Space

Default Value: 00h

Attribute: Read/Write

Size: PM2_CNT_LEN

This register block is naturally aligned and accessed based on its length. For ACPI 1.0 this register is byte aligned and accessed as a byte.

This register contains optional features enabled or disabled within the FADT. If the FADT indicates that the feature is not supported as a fixed hardware feature, then software treats these bits as ignored.

Table 4.15: PM2 Control Register Bits

Bit	Name	Description
0	ARB_DIS	This bit is used to enable and disable the system arbiter. When this bit is CLEAR the system arbiter is enabled and the arbiter can grant the bus to other bus masters. When this bit is SET the system arbiter is disabled and the default CPU has ownership of the system. OSPM clears this bit when using the C0, C1 and C2 power states.
>0	<i>Reserved</i>	<i>Reserved</i>

4.8.3.5 Processor Register Block (P_BLK)

This optional register block is used to control each processor in the system. There is one unique processor register block per processor in the system. For more information about controlling processors and control methods that can be used to control processors, see *Processor Configuration and Control*. This register block is DWORD aligned and the context of this register block is not maintained across S3 or S4 sleeping states, or the S5 soft-off state.

4.8.3.5.1 Processor Control (P_CNT): 32

Register Location: Either <P_BLK>: System I/O Space
 or specified by _PTC Object: System I/O, System Memory, or
 Functional Fixed Hardware Space

Default Value: 00h

Attribute: Read/Write

Size: 32 bits

This register is accessed as a DWORD. The CLK_VAL field is where the duty setting of the throttling hardware is programmed as described by the DUTY_WIDTH and DUTY_OFFSET values in the FADT. Software treats all other CLK_VAL bits as ignored (those not used by the duty setting value).

Table 4.16: Processor Control Register Bits

Bit	Name	Description
3:0	CLK_VAL	Possible locations for the clock throttling value.
4	THT_EN	This bit enables clock throttling of the clock as set in the CLK_VAL field. THT_EN bit must be reset LOW when changing the CLK_VAL field (changing the duty setting).
31:5	CLK_VAL	Possible locations for the clock throttling value.

4.8.3.5.2 Processor LVL2 Register (P_LVL2): 8

Register Location: Either <P_BLK> + 4: System I/O Space
 or specified by _CST Object: System I/O, System Memory, or
 Functional Fixed Hardware Space

Default Value: 00h

Attribute: Read-Only

Size: 8 bits

This register is accessed as a byte.

Table 4.17: Processor LVL2 Register Bits

Bit	Name	Description
7:0	P_LVL2	Reads to this register return all zeros; writes to this register have no effect. Reads to this register also generate an “enter a C2 power state” to the clock control logic.

4.8.3.5.3 Processor LVL3 Register (P_LVL3): 8

Register Location: Either <P_BLK> + 5: System I/O Space
 or specified by _CST Object: System I/O, System Memory, or
 Functional Fixed Hardware Space

Default Value: 00h

Attribute: Read-Only

Size: 8 bits

This register is accessed as a byte.

Table 4.18: Processor LVL3 Register Bits

Bit	Name	Description
7:0	P_LVL3	Reads to this register return all zeros; writes to this register have no effect. Reads to this register also generate an “enter a C3 power state” to the clock control logic.

4.8.3.6 Reset Register

The optional ACPI reset mechanism specifies a standard mechanism that provides a complete system reset. When implemented, this mechanism must reset the entire system. This includes processors, core logic, all buses, and all peripherals. From an OSPM perspective, asserting the reset mechanism is the logical equivalent to power cycling the system. Upon gaining control after a reset, OSPM will perform actions in like manner to a cold boot.

The reset mechanism is implemented via an 8-bit register described by RESET_REG in the FADT (always accessed via the natural alignment and size described in RESET_REG). To reset the system, software will write a value (indicated in RESET_VALUE in FADT) to the reset register. The RESET_REG field in the FADT indicates the location of the reset register.

The reset register may exist only in I/O space, Memory space, or in PCI Configuration space on a function in bus 0. Therefore, the Address_Space_ID value in RESET_REG must be set to System I/O space, System Memory space, or PCI Configuration space (with a bus number of 0). As the register is only 8 bits, Register_Bit_Width must be 8 and Register_Bit_Offset must be 0.

The system must reset immediately following the write to this register. OSPM assumes that the processor will not execute beyond the write instruction. OSPM should execute spin loops on the CPUs in the system following a write to this register.

4.8.3.7 Sleep Control and Status Registers

The optional ACPI sleep registers (SLEEP_CONTROL_REG and SLEEP_STATUS_REG) specify a standard mechanism for system sleep state entry on HW-Reduced ACPI systems. When implemented, the Sleep registers are a replacement for the SLP_TYP, SLP_EN and WAK_STS registers in the PM1_BLK. Use of these registers is at the discretion of OSPM. OSPM can decide whether to enter sleep states on the platform based on the LOW_POWER_S0_IDLE_CAPABLE flag. Even when implemented, OSPM may use other provided options for hibernate and shutdown (e.g. UEFI ResetSystem()).

The HW-reduced Sleep mechanism is implemented via two 8-bit registers described by SLEEP_CONTROL_REG and SLEEP_STATUS_REG in the FADT (always accessed via the natural alignment and size described in SLEEP*_REG). To put the system into a sleep state, software will write the HW-reduced Sleep Type value (obtained from the _Sx object in the DSDT) and the SLP_EN bit to the sleep control register. The OSPM then polls the WAK_STS bit of the SLEEP_STATUS_REG waiting for it to be one (1), indicating that the system has been transitioned back to the Working state.

The Sleep registers may exist only in I/O space, Memory space, or in PCI Configuration space on a function in bus 0. Therefore, the Address_Space_ID value must be set to System I/O space, SystemMemory space, or PCI Configuration space (with a bus number of 0). As the registers are only 8 bits, Register_Bit_Width must be 8 and Register_Bit_Offset must be 0.

Table 4.19: Sleep Control Register

Field Name	Bit Length	Bit Offset	Description
<i>Reserved</i>	1	0	Reserved. This bit is reserved by OSPM.
Ignore	1	1	Software ignores this bit field.
SLP_TYPx	3	2	Defines the type of sleeping state the system enters when the SLP_EN bit is set to one. This 3-bit field defines the type of hardware sleep state the system enters when the SLP_EN bit is set. The _Sx object contains 3-bit binary values associated with the respective sleeping state (as described by the object). OSPM takes the HW-reduced Sleep Type value from the _SX object and programs it into the SLP_TYPx field.
SLP_EN	1	5	This is a write-only bit and reads to it always return a zero. Setting this bit causes the system to sequence into the sleeping state associated with the SLP_TYPx fields programmed with the values from the _Sx object.
<i>Reserved</i>	2	6	Reserved. This field always returns zero.

Table 4.20: Sleep Status Register

Field Name	Bit Length	Bit Offset	Description
Ignore	4	0	Software ignores this bit field.
<i>Reserved</i>	2	4	Reserved. These bits always return a value of zero.
Ignore	1	6	Software ignores this bit field.
WAK_STS	1	7	This bit is set when the system is in the sleeping state and an enabled wake event occurs. Upon setting this bit system will transition to the working state. This bit is set by hardware and can only be cleared by software writing a “1” to this bit position.

4.8.4 Generic Hardware Registers

ACPI provides a mechanism that allows a unique piece of “value added” hardware to be described to OSPM in the ACPI Namespace. There are a number of rules to be followed when designing ACPI-compatible hardware.

Programming bits can reside in any of the defined generic hardware address spaces (system I/O, system memory, PCI configuration, embedded controller, or SMBus), but the top-level event bits are contained in the general-purpose event registers. The general-purpose event registers are pointed to by the GPE0_BLK and GPE1_BLK register blocks, and the generic hardware registers can be in any of the defined ACPI address spaces. A device’s generic hardware programming model is described through an associated object in the ACPI Namespace, which specifies the bit’s function, location, address space, and address location.

The programming model for devices is normally broken into status and control functions. Status bits are used to generate an event that allows OSPM to call a control method associated with the pending status bit. The called control method can then control the hardware by manipulating the hardware control bits or by investigating child status bits and calling their respective control methods. ACPI requires that the top level “parent” event status and enable bits reside in either the GPE0_STS or GPE1_STS registers, and “child” event status bits can reside in generic address space.

The example below illustrates some of these concepts. The top diagram shows how the logic is partitioned into two chips: a chipset and an embedded controller.

- The chipset contains the interrupt logic, performs the power button (which is part of the fixed register space, and is not discussed here), the lid switch (used in portables to indicate when the clam shell lid is open or closed), and the RI# function (which can be used to wake a sleeping system).
- The embedded controller chip is used to perform the AC power detect and dock/undock event logic. Additionally, the embedded controller supports some system management functions using an OS-transparent interrupt in the embedded controller (represented by the EXTSMI# signal).

At the top level, the generic events in the GPE_x_STS register are the:

- Embedded controller interrupt, which contains two query events: one for AC detection and one for docking (the docking query event has a child interrupt status bit in the docking chip).
- Ring indicate status (used for waking the system).
- Lid status.

The embedded controller event status bit (EC_STS) is used to indicate that one of two query events is active.

- A query event is generated when the AC# signal is asserted. The embedded controller returns a query value of 34 (any byte number can be used) upon a query command in response to this event; OSPM will then schedule for execution the control method associated with query value 34.

Another query event is for the docking chip that generates a docking event. In this case, the embedded controller will return a query value of 35 upon a query command from system software responding to an SCI from the embedded controller. OSPM will then schedule the control method associated with the query value of 35 to be executed, which services the docking event.

For each of the status bits in the GPE_x_STS register, there is a corresponding enable bit in the GPE_x_EN register. Notice that the child status bits do not necessarily need enable bits (see the DOCK_STS bit).

The lid logic contains a control bit to determine if its status bit is set when the LID is open (LID_POL is set and LID is set) or closed (LID_POL is clear and LID is clear). This control bit resides in generic I/O space (in this case, bit 2 of system I/O space 33h) and would be manipulated with a control method associated with the lid object.

As with fixed hardware events, OSPM will clear the status bits in the GPE_x register blocks. However, AML code clears all sibling status bits in the generic hardware.

Generic hardware features are controlled by OEM supplied control methods, encoded in AML. ACPI provides both an event and control model for development of these features. The ACPI specification also provides specific control

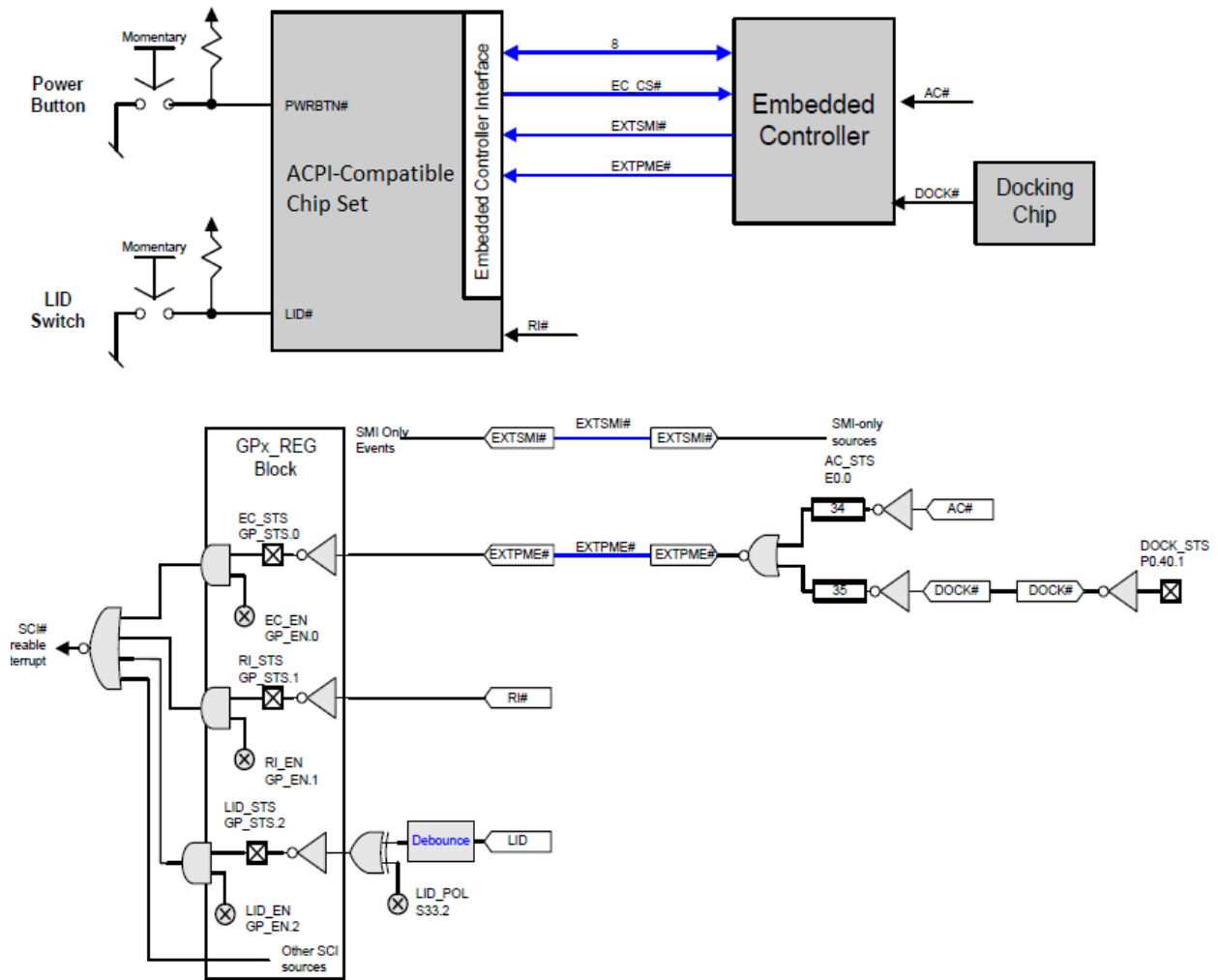

Fig. 4.13: Example of General-Purpose vs. Generic Hardware Events

methods for notifying OSPM of certain power management and Plug and Play events. *ACPI Software Programming Model* provides information on the types of hardware functionality that support the different types of subsystems. The following is a list of features supported by ACPI. The list is not intended to be complete or comprehensive.

- Device insertion/ejection (for example, docking, device bay, A/C adapter)
- Batteries *
- Platform thermal subsystem
- Turning on/off power resources
- Mobile lid Interface
- Embedded controller
- System indicators
- OEM-specific wake events
- Plug and Play configuration

Note: * ACPI operating systems assume the use of the Smart Battery System Implementers Forum defined standard for batteries, called the “Smart Battery Specification” (SBS). ACPI provides a set of control methods for use by OEMs that use a proprietary “control method” battery interface.

4.8.4.1 General-Purpose Event Register Blocks

ACPI supports up to two general-purpose register blocks as described in the FADT (see *ACPI Software Programming Model*), and an arbitrary number of additional GPE blocks described as devices within the ACPI namespace. Each register block contains two registers: an enable and a status register. Each register block is 32-bit aligned. Each register in the block is accessed as a byte. It is up to the specific design to determine if these bits retain their context across sleeping or soft-off states. If they lose their context across a sleeping or soft-off state, then platform boot firmware resets the respective enable bit prior to passing control to the OS upon waking.

4.8.4.1.1 General-Purpose Event 0 Register Block

This register block consists of two registers: The GPE0_STS and the GPE0_EN registers. Each register’s length is defined to be half the length of the GPE0 register block, and is described in the ACPI FADT’s GPE0_BLK and GPE0_BLK_LEN operators. OSPM owns the general-purpose event resources and these bits are only manipulated by OSPM; AML code cannot access the general-purpose event registers.

It is envisioned that chipsets will contain GPE event registers that provide GPE input pins for various events.

The platform designer would then wire the GPEs to the various value-added event hardware and the AML code would describe to OSPM how to utilize these events. As such, there will be the case where a platform has GPE events that are not wired to anything (they are present in the chip set), but are not utilized by the platform and have no associated AML code. In such, cases these event pins are to be tied inactive such that the corresponding SCI status bit in the GPE register is not set by a floating input pin.

4.8.4.1.1.1 General-Purpose Event 0 Status Register

Register Location: <GPE0_STS> System I/O or System Memory Space

Default Value: 00h

Attribute: Read/Write

Size: GPE0_BLK_LEN/2

The general-purpose event 0 status register contains the general-purpose event status bits in bank zero of the general-purpose registers. Each available status bit in this register corresponds to the bit with the same bit position in the GPE0_EN register. Each available status bit in this register is set when the event is active, and can only be cleared by software writing a “1” to its respective bit position. For the general-purpose event registers, unimplemented bits are ignored by OSPM.

Each status bit can optionally wake the system if asserted when the system is in a sleeping state with its respective enable bit set. OSPM accesses GPE registers through byte accesses (regardless of their length).

4.8.4.1.1.2 General-Purpose Event 0 Enable Register

Register Location: <GPE0_EN> System I/O or System Memory Space

Default Value: 00h

Attribute: Read/Write

Size: GPE0_BLK_LEN/2

The general-purpose event 0 enable register contains the general-purpose event enable bits. Each available enable bit in this register corresponds to the bit with the same bit position in the GPE0_STS register. The enable bits work similarly to how the enable bits in the fixed-event registers are defined: When the enable bit is set, then a set status bit in the corresponding status bit will generate an SCI bit. OSPM accesses GPE registers through byte accesses (regardless of their length).

4.8.4.1.2 General-Purpose Event 1 Register Block

This register block consists of two registers: The GPE1_STS and the GPE1_EN registers. Each register’s length is defined to be half the length of the GPE1 register block, and is described in the ACPI FADT’s GPE1_BLK and GPE1_BLK_LEN operators.

4.8.4.1.2.1 General-Purpose Event 1 Status Register

Register Location: <GPE1_STS> System I/O or System Memory Space

Default Value: 00h

Attribute: Read/Write

Size: GPE1_BLK_LEN/2

The general -purpose event 1 status register contains the general-purpose event status bits. Each available status bit in this register corresponds to the bit with the same bit position in the GPE1_EN register. Each available status bit in this register is set when the event is active, and can only be cleared by software writing a “1” to its respective bit position. For the general-purpose event registers, unimplemented bits are ignored by the operating system.

Each status bit can optionally wake the system if asserted when the system is in a sleeping state with its respective enable bit set.

OSPM accesses GPE registers through byte accesses (regardless of their length).

4.8.4.1.2.2 General-Purpose Event 1 Enable Register

Register Location: <GPE1_EN> System I/O or System Memory Space

Default Value: 00h

Attribute: Read/Write

Size: GPE1_BLK_LEN/2

The general-purpose event 1 enable register contains the general-purpose event enable. Each available enable bit in this register corresponds to the bit with the same bit position in the GPE1_STS register. The enable bits work similarly to how the enable bits in the fixed-event registers are defined: When the enable bit is set, a set status bit in the corresponding status bit will generate an SCI bit.

OSPM accesses GPE registers through byte accesses (regardless of their length).

4.8.4.2 Example Generic Devices

This section points out generic devices with specific ACPI driver support.

4.8.4.2.1 Lid Switch

The Lid switch is an optional feature present in most “clam shell” style mobile computers. It can be used by the OS as policy input for sleeping the system, or for waking the system from a sleeping state. If used, then the OEM needs to define the lid switch as a device with an _HID object value of “PNPOCOD”, which identifies this device as the lid switch to OSPM. The Lid device needs to contain a control method that returns its status. The Lid event handler AML code reconfigures the lid hardware (if it needs to) to generate an event in the other direction, clear the status, and then notify OSPM of the event.

Example hardware and ASL code is shown below for such a design.

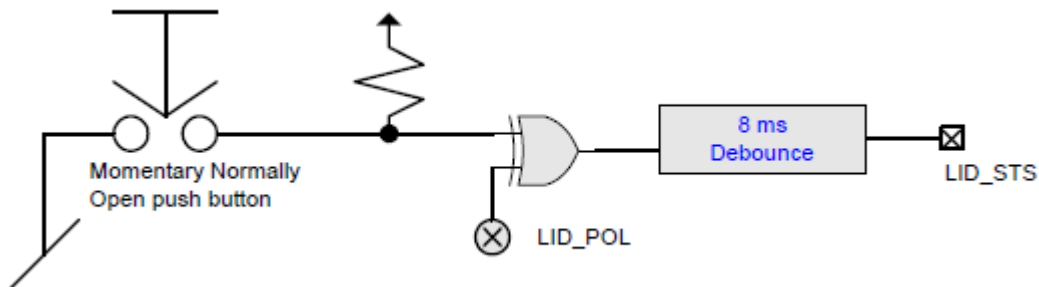

Fig. 4.14: Example Generic Address Space Lid Switch Logic

This logic will set the Lid status bit when the button is pressed or released (depending on the LID_POL bit).

The ASL code below defines the following:

- An operational region where the lid polarity resides in address space System address space in registers 0x201.
- A field operator to allow AML code to access this bit: Polarity control bit (LID_POL) is called LPOL and is accessed at 0x201.0.
- A device named _SB.LID with the following:

- A Plug and Play identifier “PNPOC0D” that associates OSPM with this object.
- Defines an object that specifies a change in the lid’s status bit can wake the system from the S4 sleep state and from all higher sleep states (S1, S2, or S3).
- The lid switch event handler that does the following:
 - Defines the lid status bit (LID_STS) as a child of the general-purpose event 0 register bit 1.
 - Defines the event handler for the lid (only event handler on this status bit) that does the following:
 - Flips the polarity of the LPOL bit (to cause the event to be generated on the opposite condition).
 - Generates a notify to the OS that does the following:
 - Passes the _SB.LID object.
- Indicates a device specific event (notify value 0x80).

```
// Define a Lid switch
OperationRegion (\PHO, SystemIO, 0x201, 0x1)
Field (\PHO, ByteAcc, NoLock, Preserve)
{
    LPOL, 1                // Lid polarity control bit
}

Device (\_SB.LID)
{
    Name (_HID, EISAID ("PNPOC0D"))
    Method (_LID)
    {
        Return(LPOL)
    }
    Name (_PRW, Package (2){
        1,                // bit 1 of GPE to enable Lid wakeup
        0x04})           // can wakeup from S4 state
}

Scope (\_GPE)
{
    Method(_L01)         // uses bit 1 of GP0_STS register
    {
        LPOL ~= LPOL    // Flip the lid polarity bit
        Notify (\_SB.LID, 0x80) // Notify OS of event
    }
}
```

4.8.4.2.2 Embedded Controller

ACPI provides a standard interface that enables AML code to define and access generic logic in “embedded controller space.” This supports current computer models where much of the value added hardware is contained within the embedded controller while allowing the AML code to access this hardware in an abstracted fashion.

- The embedded controller is defined as a device and must contain a set number of control methods:
 - `_HID` with a value of `PNPOC09` to associate this device with the ACPI’s embedded controller’s driver.
 - `_CRS` to return the resources being consumed by the embedded controller.
 - `_GPE` that returns the general-purpose event bit that this embedded controller is wired to.

Additionally the embedded controller can support up to 255 generic events per embedded controller, referred to as query events. These query event handles are defined within the embedded controller's device as control methods. An example of defining an embedded controller device is shown below:

```
Device (EC0) {
    // PnP ID
    Name (_HID, EISAID("PNP0C09"))
    // Returns the "Current Resources" of EC
    Name (_CRS, ResourceTemplate()
    {
        IO(Decode16, 0x62, 0x62, 0, 1)
        IO(Decode16, 0x66, 0x66, 0, 1)
    })

    // Indicate that the EC SCI is bit 0 of the GP_STS register
    Name (_GPE, 0) // embedded controller is wired to bit 0 of GPE
    OperationRegion (\EC0, EmbeddedControl, 0, 0xFF)
    Field (EC0, ByteAcc, Lock, Preserve)
    {
        // Field units of EC0
    }

    // Query methods
    Method(_Q00)
    { ... }
    Method(_QFF)
    { ... }
}
```

For more information on the embedded controller, see *ACPI Embedded Controller Interface Specification*

4.8.4.2.3 Fan

ACPI has a device driver to control fans (active cooling devices) in platforms. A fan is defined as a device with the Plug and Play ID of "PNP0C0B." It should then contain a list power resources used to control the fan.

For more information, see *ACPI-Defined Devices and Device-Specific Objects*.

LA2PA_TRANSLATION .. highlight:: none

ACPI SOFTWARE PROGRAMMING MODEL

ACPI defines a hardware register interface that an ACPI-compatible OS uses to control core power management features of a machine, as described in *ACPI Hardware Specification*. ACPI also provides an abstract interface for controlling the power management and configuration of an ACPI system. Finally, ACPI defines an interface between an ACPI-compatible OS and the platform runtime firmware.

To give hardware vendors flexibility in choosing their implementation, ACPI uses tables to describe system information, features, and methods for controlling those features. These tables list devices on the system board or devices that cannot be detected or power managed using some other hardware standard, plus their capabilities as described in *ACPI Concepts*. They also list system capabilities such as the sleeping power states supported, a description of the power planes and clock sources available in the system, batteries, system indicator lights, and so on. This enables OSPM to control system devices without needing to know how the system controls are implemented.

Topics covered in this section are:

- The ACPI system description table architecture is defined, and the role of OEM-provided definition blocks in that architecture is discussed.
- The concept of the ACPI Namespace is discussed.

5.1 Overview of the System Description Table Architecture

The *Root System Description Pointer (RSDP)* structure is located in the system's memory address space and is setup by the platform firmware. This structure contains the address of the *Extended System Description Table (XSDT)*, which references other description tables that provide data to OSPM, supplying it with knowledge of the base system's implementation and configuration (see *Root System Description Pointer and Table*).

All system description tables start with identical headers. The primary purpose of the system description tables is to define for OSPM various industry-standard implementation details. Such definitions enable various portions of these implementations to be flexible in hardware requirements and design, yet still provide OSPM with the knowledge it needs to control hardware directly.

The *Extended System Description Table (XSDT)* points to other tables in memory. Always the first table, it points to the *Fixed ACPI Description Table (FADT)*. The data within this table includes various fixed-length entries that describe the fixed ACPI features of the hardware. The FADT table always refers to the *Differentiated System Description Table (DSDT)*, which contains information and descriptions for various system features. The relationship between these tables is shown in *Description Table Structures*.

OSPM finds the RSDP structure as described in *Finding the RSDP on IA-PC Systems* ("Finding the RSDP on IA-PC Systems") or *Finding the RSDP on UEFI Enabled Systems* ("Finding the RSDP on UEFI Enabled Systems").

When OSPM locates the structure, it looks at the physical address for the Root System Description Table or the Extended System Description Table. The Root System Description Table starts with the signature "RSDT", while the Extended System Description Table starts with the signature "XSDT". These tables contain one or more physical

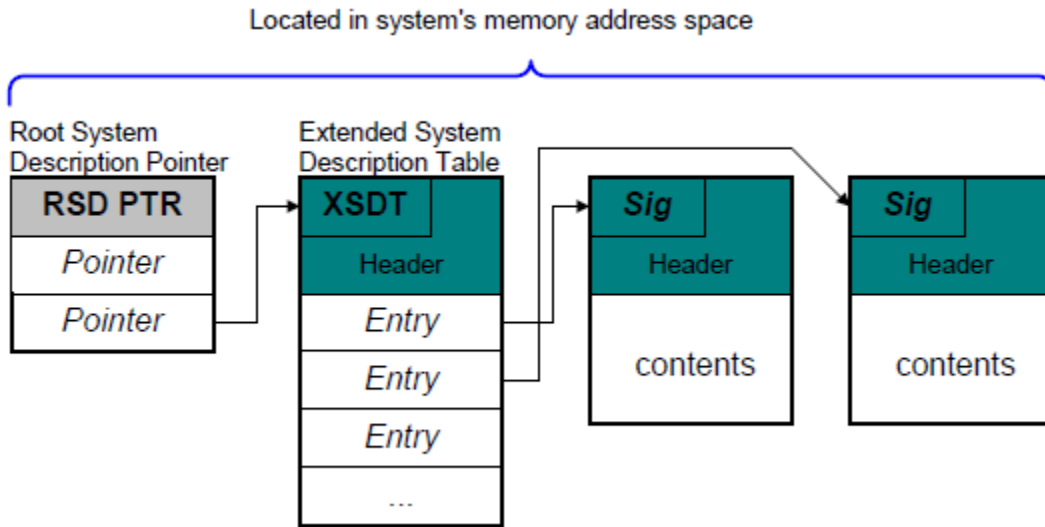

Fig. 5.1: Root System Description Pointer and Table

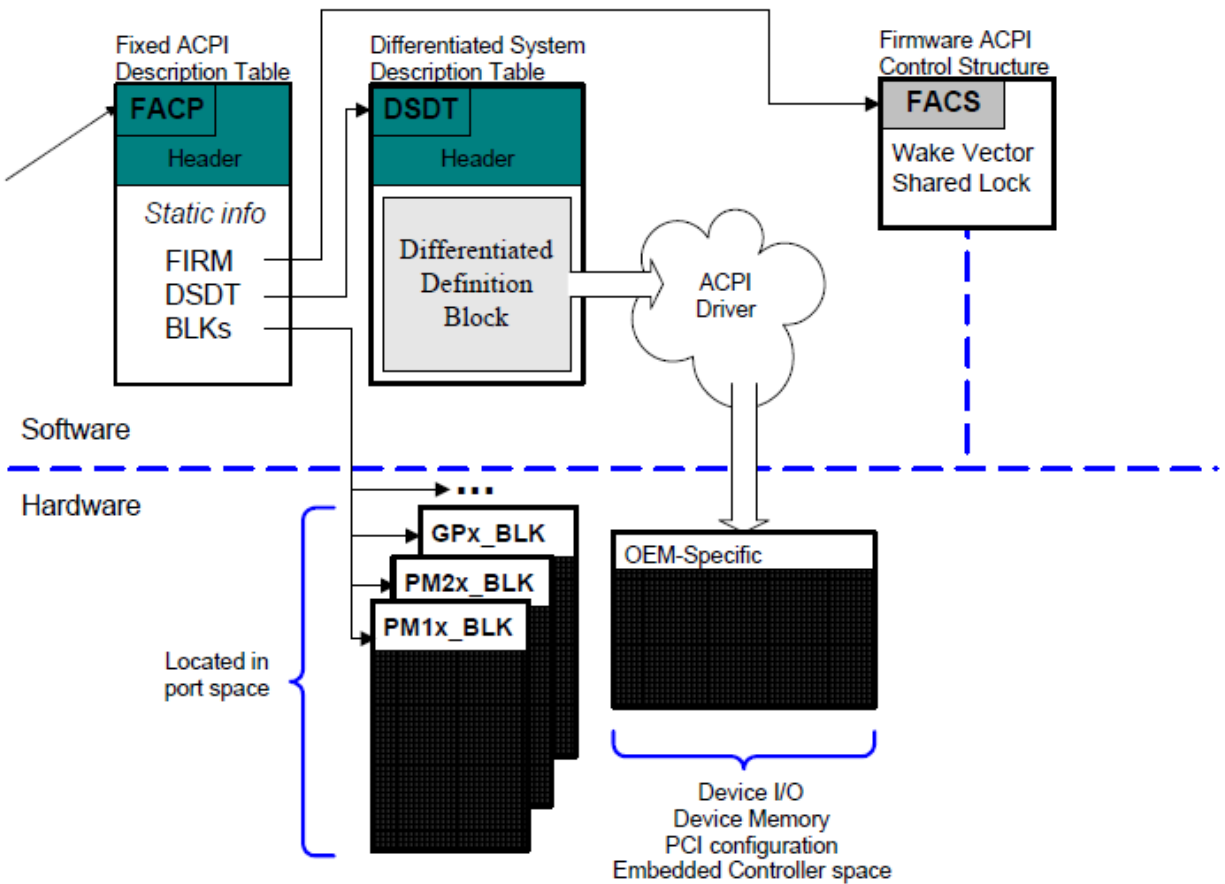

Fig. 5.2: Description Table Structures

pointers to other system description tables that provide various information about the system. As shown in *Description Table Structures*, there is always a physical address in the Root System Description Table for the *Fixed ACPI Description Table (FADT)*.

When OSPM follows a physical pointer to another table, it examines each table for a known signature. Based on the signature, OSPM can then interpret the implementation-specific data within the description table.

The purpose of the FADT is to define various static system information related to configuration and power management. The Fixed ACPI Description Table starts with the “FACP” signature. The FADT describes the implementation and configuration details of the ACPI hardware registers on the platform.

For a specification of the ACPI Hardware Register Blocks (PM1a_EVT_BLK, PM1b_EVT_BLK, PM1a_CNT_BLK, PM1b_CNT_BLK, PM2_CNT_BLK, PM_TMR_BLK, GP0_BLK, GP1_BLK, and one or more P_BLKs), see *ACPI Register Model*. The PM1a_EVT_BLK, PM1b_EVT_BLK, PM1a_CNT_BLK, PM1b_CNT_BLK, PM2_CNT_BLK, and PM_TMR_BLK blocks are for controlling low-level ACPI system functions.

The GPE0_BLK and GPE1_BLK blocks provide the foundation for an interrupt-processing model for Control Methods. The P_BLK blocks are for controlling processor features.

Besides ACPI Hardware Register implementation information, the FADT also contains a physical pointer to a data structure known as the *Differentiated System Description Table (DSDT)*, which is encoded in Definition Block format (See *Definition Blocks*).

A Definition Block contains information about the platform’s hardware implementation details in the form of data objects arranged in a hierarchical (tree-structured) entity known as the “ACPI namespace”, which represents the platform’s hardware configuration. All definition blocks loaded by OSPM combine to form one namespace that represents the platform. Data objects are encoded in a format known as ACPI Machine Language or AML for short. Data objects encoded in AML are “evaluated” by an OSPM entity known as the AML interpreter. Their values may be static or dynamic. The AML interpreter’s dynamic data object evaluation capability includes support for programmatic evaluation, including accessing address spaces (for example, I/O or memory accesses), calculation, and logical evaluation, to determine the result. Dynamic namespace objects are known as “control methods”. OSPM “loads” an entire definition block as a logical unit - adding to or removing the associated objects from the namespace. The DSDT contains a Definition Block named the Differentiated Definition Block that contains implementation and configuration information OSPM can use to perform power management, thermal management, or Plug and Play functionality that goes beyond the information described by the ACPI hardware registers.

Definition Blocks can either define new system attributes or, in some cases, build on prior definitions. A Definition Block can be loaded from system memory address space. One use of a Definition Block is to describe and distribute platform version changes.

Definition blocks enable wide variations of hardware platform implementations to be described to the ACPI-compatible OS while confining the variations to reasonable boundaries. Definition blocks enable simple platform implementations to be expressed by using a few well-defined object names. In theory, it might be possible to define a PCI configuration space-like access method within a Definition Block, by building it from I/O space, but that is not the goal of the Definition Block specification. Such a space is usually defined as a “built in” operator.

Some operators perform simple functions and others encompass complex functions. The power of the Definition Block comes from its ability to allow these operations to be glued together in numerous ways, to provide functionality to OSPM. The operators present are intended to allow many useful hardware designs to be ACPI-expressed, not to allow all hardware designs to be expressed.

5.1.1 Address Space Translation

Some platforms may contain bridges that perform translations as I/O and/or Memory cycles pass through the bridges. This translation can take the form of the addition or subtraction of an offset. Or it can take the form of a conversion from I/O cycles into Memory cycles and back again. When translation takes place, the addresses placed on the processor bus by the processor during a read or write cycle are not the same addresses that are placed on the I/O bus by the I/O bus bridge. The address the processor places on the processor bus will be known here as the processor-relative address. And the address that the bridge places on the I/O bus will be known as the bus-relative address. Unless otherwise noted, all addresses used within this section are processor-relative addresses.

For example, consider a platform with two root PCI buses. The platform designer has several choices. One solution would be to split the 16-bit I/O space into two parts, assigning one part to the first root PCI bus and one part to the second root PCI bus. Another solution would be to make both root PCI buses decode the entire 16-bit I/O space, mapping the second root PCI bus's I/O space into memory space. In this second scenario, when the processor needs to read from an I/O register of a device underneath the second root PCI bus, it would need to perform a memory read within the range that the root PCI bus bridge is using to map the I/O space.

- Industry standard PCs do not provide address space translations because of historical compatibility issues.

5.2 ACPI System Description Tables

This section specifies the structure of the system description tables:

- *Generic Address Structure (GAS)*
- *Root System Description Pointer (RSDP)*
- *System Description Table Header*
- *Root System Description Table (RSDT)*
- *Extended System Description Table (XSDT)*
- *Fixed ACPI Description Table (FADT)*
- *Firmware ACPI Control Structure (FACS)*
- *Differentiated System Description Table (DSDT)*
- *Secondary System Description Table (SSDT)*
- *Multiple APIC Description Table (MADT)*
- *GIC CPU Interface (GICC) Structure*
- *Smart Battery Table (SBST)*
- *Extended System Description Table (XSDT)*
- *Embedded Controller Boot Resources Table (ECDT)*
- *System Locality Information Table (SLIT)*
- *System Resource Affinity Table (SRAT)*
- *Corrected Platform Error Polling Table (CPEP)*
- *Maximum System Characteristics Table (MSCT)*
- *ACPI RAS Feature Table (RAS_F)*
- *ACPI RAS2 Feature Table (RAS2)*
- *Memory Power State Table (MPST)*

- *Platform Memory Topology Table (PMTT)*
- *Boot Graphics Resource Table (BGRT)*
- *Firmware Performance Data Table (FPDT)*
- *Generic Timer Description Table (GTDT)*
- *NVDIMM Firmware Interface Table (NFIT)*
- *Heterogeneous Memory Attribute Table (HMAT)*
- *Platform Debug Trigger Table (PDTT)*
- *Processor Properties Topology Table (PPTT)*

All numeric values in ACPI-defined tables, blocks, and structures are always encoded in little endian format. Signature values are stored as fixed-length strings.

5.2.1 Reserved Bits and Fields

For future expansion, all data items marked as reserved in this specification have strict meanings. This section lists software requirements for reserved fields. Notice that the list contains terms such as ACPI tables and AML code defined later in this section of the specification.

5.2.1.1 Reserved Bits and Software Components

- OEM implementations of software and AML code return the bit value of 0 for all reserved bits in ACPI tables or in other software values, such as resource descriptors.
- For all reserved bits in ACPI tables and registers, OSPM implementations must:
- Ignore all reserved bits that are read.
- Preserve reserved bit values of read/write data items (for example, OSPM writes back reserved bit values it reads).
- Write zeros to reserved bits in write-only data items.

5.2.1.2 Reserved Values and Software Components

- OEM implementations of software and AML code return only defined values and do not return reserved values.
- OSPM implementations write only defined values and do not write reserved values.

5.2.1.3 Reserved Hardware Bits and Software Components

- Software ignores all reserved bits read from hardware enable or status registers.
- Software writes zero to all reserved bits in hardware enable registers.
- Software ignores all reserved bits read from hardware control and status registers.
- Software preserves the value of all reserved bits in hardware control registers by writing back read values.

5.2.1.4 Ignored Hardware Bits and Software Components

- Software handles ignored bits in ACPI hardware registers the same way it handles reserved bits in these same types of registers.

5.2.2 Compatibility

All versions of the ACPI tables must maintain backward compatibility. To accomplish this, modifications of the tables consist of redefinition of previously reserved fields and values plus appending data to the 1.0 tables. Modifications of the ACPI tables require that the version numbers of the modified tables be incremented. The length field in the tables includes all additions and the checksum is maintained for the entire length of the table.

5.2.3 Address Format

Addresses used in the ACPI 1.0 system description tables were expressed as either system memory or I/O space. This was targeted at the IA-32 environment. Newer architectures require addressing mechanisms beyond that defined in ACPI 1.0. To support these architectures ACPI must support 64-bit addressing and it must allow the placement of control registers in address spaces other than System I/O.

5.2.3.1 Functional Fixed Hardware

ACPI defines the fixed hardware low-level interfaces as a means to convey to the system OEM the minimum interfaces necessary to achieve a level of capability and quality for motherboard configuration and system power management. Additionally, the definition of these interfaces, as well as others defined in this specification, conveys to OS Vendors (OSVs) developing ACPI-compatible operating systems, the necessary interfaces that operating systems must manipulate to provide robust support for system configuration and power management.

While the definition of low-level hardware interfaces defined by ACPI 1.0 afforded OSPM implementations a certain level of stability, controls for existing and emerging diverse CPU architectures cannot be accommodated by this model as they can require a sequence of hardware manipulations intermixed with native CPU instructions to provide the ACPI-defined interface function. In this case, an ACPI-defined fixed hardware interface can be functionally implemented by the CPU manufacturer through an equivalent combination of both hardware and software and is defined by ACPI as Functional Fixed Hardware.

In IA-32-based systems, functional fixed hardware can be accommodated in an OS independent manner by using System Management Mode (SMM) based system firmware. Unfortunately, the nature of SMM-based code makes this type of OS independent implementation difficult if not impossible to debug. As such, this implementation approach is not recommended. In some cases, Functional Fixed Hardware implementations may require coordination with other OS components. As such, an OS independent implementation may not be viable.

OS-specific implementations of functional fixed hardware can be implemented using technical information supplied by the CPU manufacturer. The downside of this approach is that functional fixed hardware support must be developed for each OS. In some cases, the CPU manufacturer may provide a software component providing this support. In other cases support for the functional fixed hardware may be developed directly by the OS vendor.

The hardware register definition was expanded, in ACPI 2.0, to allow registers to exist in address spaces other than the System I/O address space. This is accomplished through the specification of an address space ID in the register definition (see *Generic Address Structure* for more information). When specifically directed by the CPU manufacturer, the system firmware may define an interface as functional fixed hardware by indicating 0x7F (Functional Fixed Hardware), in the address space ID field for register definitions. It is emphasized that functional fixed hardware definitions may be declared in the ACPI system firmware only as indicated by the CPU Manufacturer for specific interfaces as the use of functional fixed hardware requires specific coordination with the OS vendor.

Only certain ACPI-defined interfaces may be implemented using functional fixed hardware and only when the interfaces are common across machine designs for example, systems sharing a common CPU architecture that does not support fixed hardware implementation of an ACPI-defined interface. OEMs are cautioned not to anticipate that functional fixed hardware support will be provided by OSPM differently on a system-by-system basis. The use of functional fixed hardware carries with it a reliance on OS specific software that must be considered. OEMs should consult OS vendors to ensure that specific functional fixed hardware interfaces are supported by specific operating systems.

- FFH is permitted and applicable to both full and HW-reduced ACPI implementations.

5.2.3.2 Generic Address Structure

The Generic Address Structure (GAS) provides the platform with a robust means to describe register locations. This structure, described below (*Generic Address Structure (GAS)*), is used to express register addresses within tables defined by ACPI.

Table 5.1: **Generic Address Structure (GAS)**

Field	Byte Length	Byte Offset	Description
Address Space ID	1	0	The address space where the data structure or register exists. Defined values are: 0x00 System Memory space 0x01 System I/O space 0x02 PCI Configuration space 0x03 Embedded Controller 0x04 SMBus 0x05 SystemCMOS 0x06 PciBarTarget 0x07 IPMI 0x08 General PurposeIO 0x09 GenericSerialBus 0x0A Platform Communications Channel (PCC) 0x0B Platform Runtime Mechanism (PRM) 0x0C to 0x7E <i>Reserved</i> 0x7F Functional Fixed Hardware 0x80 to 0xFF OEM Defined
Register Bit Width	1	1	The size in bits of the given register. When addressing a data structure, this field must be zero.
Register Bit Offset	1	2	The bit offset of the given register at the given address. When addressing a data structure, this field must be zero.

continues on next page

Table 5.1 – continued from previous page

Field	Byte Length	Byte Offset	Description
Access Size	1	3	Specifies access size. Unless otherwise defined by the Address Space ID: 0 Undefined (legacy reasons) 1 Byte access 2 Word access 3 Dword access 4 QWord access
Address	8	4	The 64-bit address of the data structure or register in the given address space (relative to the processor). (See below for specific formats.)

Table 5.2: Address Space Format

Address Space	Format
0-System Memory	The 64-bit physical memory address (relative to the processor) of the register. 32-bit platforms must have the high DWORD set to 0.
1-System I/O	The 64-bit I/O address (relative to the processor) of the register. 32-bit platforms must have the high DWORD set to 0.
2-PCI Configuration Space	<p>PCI Configuration space addresses must be confined to devices on PCI Segment Group 0, bus 0. This restriction exists to accommodate access to fixed hardware prior to PCI bus enumeration. The format of addresses are defined as follows:</p> <p>Word Location Description</p> <p>Highest Word Reserved (must be 0)</p> <ul style="list-style-type: none"> — PCI Device number on bus 0 — PCI Function number <p>Longest Word Offset in the configuration space header</p> <p>For example: Offset 23h of Function 2 on device 7 on bus 0 segment 0 would be represented as: 0x0000000700020023.</p>
6-PCI BAR Target	<p>PciBarTarget is used to locate a MMIO register on a PCI device BAR space. PCI Configuration space addresses must be confined to devices on a host bus, i.e any bus returned by a _BBN object. This restriction exists to accommodate access to fixed hardware prior to PCI bus enumeration. The format of the Address field for this type of address is:</p> <ul style="list-style-type: none"> Bits [63:56] – PCI Segment Bits [55:48] – PCI Bus Bits [47:43] – PCI Device Bits [42:40] – PCI Function Bits [39:37] – BAR index# Bits [36:0] – Offset from BAR in DWORDs
0x0A-PCC	{Definition needed}

continues on next page

Table 5.2 – continued from previous page

Address Space	Format
0x7F-Functional Fixed Hardware	Use of GAS fields other than Address_Space_ID is specified by the CPU manufacturer. The use of functional fixed hardware carries with it a reliance on OS specific software that must be considered. OEMs should consult OS vendors to ensure that specific functional fixed hardware interfaces are supported by specific operating systems.

5.2.4 Universally Unique Identifiers (UUIDs)

UUIDs (Universally Unique Identifiers), also known as GUIDs (Globally Unique Identifiers) are 128 bit long values that extremely likely to be different from all other UUIDs generated until 3400 A.D. UUIDs are used to distinguish between callers of ASL methods, such as `_DSM` and `_OSC`. UUIDs are also used to distinguish individual entries in the MISC table.

The format of both the binary and string representations of UUIDs, along with an algorithm to generate them, is specified in [ISO/IEC 11578:1996 Information technology - Open Systems Interconnection - Remote Procedure Call \(RPC\)](#). This can also be found as part of the [DCE 1.1: Remote Procedure Call technical standard](#), and in the [Wikipedia entry for UUIDs](#).

5.2.5 Root System Description Pointer (RSDP)

During OS initialization, OSPM must obtain the Root System Description Pointer (RSDP) structure from the platform. When OSPM locates the Root System Description Pointer (RSDP) structure, it then locates the Root System Description Table (RSDT) or the Extended Root System Description Table (XSDT) using the physical system address supplied in the RSDP.

5.2.5.1 Finding the RSDP on IA-PC Systems

OSPM finds the Root System Description Pointer (RSDP) structure by searching physical memory ranges on 16-byte boundaries for a valid Root System Description Pointer structure signature and checksum match as follows:

- The first 1 KB of the Extended BIOS Data Area (EBDA). For EISA or MCA systems, the EBDA can be found in the two-byte location 40:0Eh on the BIOS data area.
- The BIOS read-only memory space between 0E0000h and 0FFFFFFh.

5.2.5.2 Finding the RSDP on UEFI Enabled Systems

In Unified Extensible Firmware Interface (UEFI) enabled systems, a pointer to the RSDP structure exists within the EFI System Table. The OS loader is provided a pointer to the EFI System Table at invocation. The OS loader must retrieve the pointer to the RSDP structure from the EFI System Table and convey the pointer to OSPM, using an OS dependent data structure, as part of the hand off of control from the OS loader to the OS.

The OS loader locates the pointer to the RSDP structure by examining the EFI Configuration Table within the EFI System Table. EFI Configuration Table entries consist of Globally Unique Identifier (GUID)/table pointer pairs. The UEFI specification defines two GUIDs for ACPI; one for ACPI 1.0 and the other for ACPI 2.0 or later specification revisions.

The EFI GUID for a pointer to the ACPI 1.0 specification RSDP structure is:

- eb9d2d30-2d88-11d3-9a16-0090273fc14d.

The EFI GUID for a pointer to the ACPI 2.0 or later specification RSDP structure is:

- 8868e871-e4f1-11d3-bc22-0080c73c8881.

The OS loader for an ACPI-compatible OS will search for an RSDP structure pointer (*RSDP Structure*) using the current revision GUID first and if it finds one, will use the corresponding RSDP structure pointer. If the GUID is not found then the OS loader will search for the RSDP structure pointer using the ACPI 1.0 version GUID.

The OS loader must retrieve the pointer to the RSDP structure from the EFI System Table before assuming platform control via the EFI ExitBootServices interface. See the UEFI Specification for more information.

5.2.5.3 Root System Description Pointer (RSDP) Structure

The revision number contained within the structure indicates the size of the table structure.

Table 5.3: RSDP Structure

Field	Byte Length	Byte Offset	Description
Signature	8	0	“RSD PTR ” (Notice that this signature must contain a trailing blank character.)
Checksum	1	8	This is the checksum of the fields defined in the ACPI 1.0 specification. This includes only the first 20 bytes of this table, bytes 0 to 19, including the checksum field. These bytes must sum to zero.
OEMID	6	9	An OEM-supplied string that identifies the OEM.
Revision	1	15	The revision of this structure. Larger revision numbers are backward compatible to lower revision numbers. The ACPI version 1.0 revision number of this table is zero. The ACPI version 1.0 RSDP Structure only includes the first 20 bytes of this table, bytes 0 to 19. It does not include the Length field and beyond. The current value for this field is 2.
RsdtdAddress	4	16	32 bit physical address of the RSDT.
Length*	4	20	The length of the table, in bytes, including the header, starting from offset 0. This field is used to record the size of the entire table. This field is not available in the ACPI version 1.0 RSDP Structure.
XsdtAddress*	8	24	64 bit physical address of the XSDT.
Extended Checksum*	1	32	This is a checksum of the entire table, including both checksum fields.
Reserved*	3	33	Reserved field

* These fields are only valid when the Revision value is 2 or above.

5.2.6 System Description Table Header

All system description tables begin with the structure shown in the *DESCRIPTION_HEADER Fields*. The Signature field in this table determines the content of the system description table. Also see Table 5.5.

Table 5.4: DESCRIPTION_HEADER Fields

Field	Byte Length	Byte Offset	Description
Signature	4	0	The ASCII string representation of the table identifier. Note that if OSPM finds a signature in a table that is not listed in Table 5.5, then OSPM ignores the entire table (it is not loaded into ACPI namespace); OSPM ignores the table even though the values in the Length and Checksum fields are correct.
Length	4	4	The length of the table, in bytes, including the header, starting from offset 0. This field is used to record the size of the entire table.
Revision	1	8	The revision of the structure corresponding to the signature field for this table. Larger revision numbers are backward compatible to lower revision numbers with the same signature.
Checksum	1	9	The entire table, including the checksum field, must add to zero to be considered valid.
OEMID	6	10	An OEM-supplied string that identifies the OEM.
OEM Table ID	8	16	An OEM-supplied string that the OEM uses to identify the particular data table. This field is particularly useful when defining a definition block to distinguish definition block functions. The OEM assigns each dissimilar table a new OEM Table ID.
OEM Revision	4	24	An OEM-supplied revision number. Larger numbers are assumed to be newer revisions.
Creator ID	4	28	Vendor ID of utility that created the table. For tables containing Definition Blocks, this is the ID for the ASL Compiler.
Creator Revision	4	32	Revision of utility that created the table. For tables containing Definition Blocks, this is the revision for the ASL Compiler.

For OEMs, good design practices will ensure consistency when assigning OEMID and OEM Table ID fields in any table. The intent of these fields is to allow for a binary control system that support services can use. Because many support functions can be automated, it is useful when a tool can programmatically determine which table release is a compatible and more recent revision of a prior table on the same OEMID and OEM Table ID.

Table 5.5 and Table 5.6 contain the system description table signatures defined by this specification. These system description tables may be defined by ACPI and documented within this specification, or they may simply be reserved by ACPI and defined by other industry specifications. This allows OS and platform specific tables to be defined and pointed to by the RSDT/XSDT as needed. For tables defined by other industry specifications, the ACPI specification acts as gatekeeper to avoid collisions in table signatures.

Table signatures will be reserved by the ACPI promoters and posted independently of this specification in ACPI errata and clarification documents on the ACPI web site. Requests to reserve a 4-byte alphanumeric table signature should be sent to the email address info@acpi.info and should include the purpose of the table and reference URL to a document that describes the table format. Tables defined outside of the ACPI specification may define data value encodings in either little endian or big endian format. For the purpose of clarity, external table definition documents should include the endian-ness of their data value encodings.

Since reference URLs can change over time and may not always be up-to-date in this specification, a separate document containing the latest known reference URLs can be found at “Links to ACPI-Related Documents” (<http://uefi.org/acpi>)

), which should conspicuously be placed in the same location as this specification.

Table 5.5: **DESCRIPTION_HEADER** Signatures for tables defined by ACPI

Signature	Description	Reference
“APIC”	Multiple APIC Description Table	Section 5.2.12
“BERT”	Boot Error Record Table	Section 18.3.1
“BGRT”	Boot Graphics Resource Table	Section 5.2.23
“CELT”	Virtual Firmware Confidential Computing Event Log Table. See Links to ACPI-Related Documents under the heading “Virtual Firmware Confidential Computing Event Log Table”.	
“CPEP”	Corrected Platform Error Polling Table	Section 5.2.18
“DSDT”	Differentiated System Description Table	Section 5.2.11.1
“ECDT”	Embedded Controller Boot Resources Table	Section 5.2.15
“EINJ”	Error Injection Table	Section 18.6.1
“ERST”	Error Record Serialization Table	Section 18.5
“FACP”	Fixed ACPI Description Table (FADT)	Section 5.2.9
“FACS”	Firmware ACPI Control Structure	Section 5.2.10
“FPDT”	Firmware Performance Data Table	Section 5.2.24
“GTDT”	Generic Timer Description Table	Section 5.2.25
“HEST”	Hardware Error Source Table	Section 18.3.2
“MISC”	Miscellaneous GUIDed Table Entries	Section 5.2.33
“MSCT”	Maximum System Characteristics Table	Section 5.2.19
“MPST”	Memory Power State Table	Section 5.2.22
“NFIT”	NVDIMM Firmware Interface Table	Section 5.2.26
“OEMx”	OEM Specific Information Tables	OEM Specific tables. All table signatures starting with “OEM” are reserved for OEM use.
“PCCT”	Platform Communications Channel Table	Section 14.1
“PHAT”	Platform Health Assessment Table	Section 5.2.31
“PMTT”	Platform Memory Topology Table	Section 5.2.22.12
“PPTT”	Processor Properties Topology Table	Section 5.2.30
“PSDT”	Persistent System Description Table	Section 5.2.11.3
“RAS2”	ACPI RAS2 Feature Table	Section 5.2.21
“RAS2”	ACPI RAS2 Feature Table	Section 5.2.21
“RSDT”	Root System Description Table	Section 5.2.7
“SBST”	Smart Battery Specification Table	Section 5.2.14
“SDEV”	Secure DEVICES Table	Section 5.2.27
“SLIT”	System Locality Distance Information Table	Section 5.2.17
“SRAT”	System Resource Affinity Table	Section 5.2.16
“SSDT”	Secondary System Description Table	Section 5.2.11.2
“SVKL”	Storage Volume Key Data table in the Intel Trusted Domain Extensions. See Links to ACPI-Related Documents under the heading “Storage Volume Key Data”.	
“XSDT”	Extended System Description Table	Section 5.2.8

Table 5.6: DESCRIPTION_HEADER Signatures for tables reserved by ACPI

Signature	Description and External Reference
“AEST”	Arm Error Source Table. See Links to ACPI-Related Documents under the heading “Arm Error Source Table”.
“AGDI”	Arm Generic Diagnostic Dump and Reset Interface. See Links to ACPI-Related Documents under the heading “Arm Generic Diagnostic Dump and Reset Interface”.
“APMT”	Arm Performance Monitoring Unit table. See Links to ACPI-Related Documents under the heading “Arm Performance Monitoring Unit table”.
“BDAT”	BIOS Data ACPI Table – exposing platform margining data. See Links to ACPI-Related Documents under the heading “BIOS Data ACPI Table”.
“BOOT”	Reserved Signature
“CEDT”	CXL Early Discovery Table. See “Links to ACPI-Related Documents” (http://uefi.org/acpi) under the heading “CXL Early Discovery Table”.
“CSRT”	Core System Resource Table. See Links to ACPI-Related Documents under the heading “Core System Resource Table”.
“DBGP”	Debug Port Table. See Links to ACPI-Related Documents under the heading “Debug Port Table”.
“DBG2”	Debug Port Table 2. See Links to ACPI-Related Documents under the heading “Debug Port Table 2”.
“DMAR”	DMA Remapping Table. See Links to ACPI-Related Documents under the heading “DMA Remapping Table”.
“DRTM”	Dynamic Root of Trust for Measurement Table. See Links to ACPI-Related Documents under the heading “TCG D-RTM Architecture Specification”.
“DTPR”	DMA TXT Protected Range. See Links to ACPI-Related Documents under the heading “DMA TXT Protected Range”.
“ETDT”	Event Timer Description Table (Obsolete). IA-PC Multimedia Timers Specification. This signature has been superseded by “HPET” (below) and is now obsolete.
“HPET”	IA-PC High Precision Event Timer Table. See Links to ACPI-Related Documents under the heading “IA-PC High Precision Event Timer Table”.
“IBFT”	iSCSI Boot Firmware Table. See Links to ACPI-Related Documents under the heading “iSCSI Boot Firmware Table”.
“IERS”	Inline Encryption Reporting Structure. See Links to ACPI-Related Documents under the heading “Inline Encryption Reporting Structure”
“IORT”	I/O Remapping Table. See Links to ACPI-Related Documents under the heading “I/O Remapping Table”.
“IVRS”	I/O Virtualization Reporting Structure. See Links to ACPI-Related Documents under the heading “I/O Virtualization Reporting Structure”.
“KEYP”	Key Programming Interface for Root Complex Integrity and Data Encryption (IDE). See Links to ACPI-Related Documents under the heading “Key Programming Interface for Root Complex Integrity and Data Encryption (IDE)”.
“LPIT”	Low Power Idle Table. See Links to ACPI-Related Documents under the heading “Low Power Idle Table”.
“MCFG”	PCI Express Memory-mapped Configuration Space base address description table. PCI Firmware Specification, Revision 3.0. See Links to ACPI-Related Documents under the heading “PCI Sig”.
“MCHI”	Management Controller Host Interface table. DSP0256 Management Component Transport Protocol (MCTP) Host Interface Specification. See Links to ACPI-Related Documents under the heading “Management Controller Host Interface Table”.
“MHSP”	Microsoft Pluton Security Processor Table. See Links to ACPI-Related Documents under the heading “Microsoft Pluton Security Processor Table”.

continues on next page

Table 5.6 – continued from previous page

Signature	Description and External Reference
“MPAM”	Arm Memory Partitioning And Monitoring . See Links to ACPI-Related Documents under the heading “Arm Memory Partitioning And Monitoring”.
“MSDM”	Microsoft Data Management Table . See Links to ACPI-Related Documents under the heading “Microsoft Software Licensing Tables”.
“NBFT”	NVMe-over-Fabric (NVMe-oF) Boot Firmware Table . See Links to ACPI-Related Documents under the heading “NVMe-over-Fabric (NVMe-oF) Boot Firmware Table”.
“PRMT”	Platform Runtime Mechanism Table . See Links to ACPI-Related Documents under the heading “Platform Runtime Mechanism Table”.
“RGRT”	Regulatory Graphics Resource Table . See Links to ACPI-Related Documents under the heading “Regulatory Graphics Resource Table”.
“SDEI”	Software Delegated Exceptions Interface . See Links to ACPI-Related Documents under the heading “Software Delegated Exceptions Interface.”
“SLIC”	Microsoft Software Licensing table. See Links to ACPI-Related Documents under the heading “Microsoft Software Licensing Table Specification”.
“SPCR”	Microsoft Serial Port Console Redirection table. See Links to ACPI-Related Documents under the heading “Serial Port Console Redirection Table”.
“SPMI”	Server Platform Management Interface table. See Links to ACPI-Related Documents under the heading “Server Platform Management Interface Table”.
“STAO”	_STA Override table. See Links to ACPI-Related Documents under the heading “_STA Override Table”.
“SWFT”	Sound Wire File Table table. See Links to ACPI-Related Documents under the heading “Sound Wire File Table”.
“TCPA”	Trusted Computing Platform Alliance Capabilities Table. TCPA PC Specific Implementation Specification. See Links to ACPI-Related Documents under the heading “Trusted Computing Platform Alliance Capabilities Table”.
“TPM2”	Trusted Platform Module 2 Table. See Links to ACPI-Related Documents under the heading “Trusted Platform Module 2 Table”.
“UEFI”	Unified Extensible Firmware Interface Specification. See the UEFI Specifications web page.
“WAET”	Windows ACPI Emulated Devices Table**. See Links to ACPI-Related Documents under the heading “Windows ACPI Emulated Devices Table”.
“WDAT”	Watch Dog Action Table . Requirements for Hardware Watchdog Timers Supported by Windows - Design Specification. See Links to ACPI-Related Documents under the heading “Watchdog Action Table (WDAT)”.
“WDDT”	Watchdog Descriptor Table . The table passes Watchdog-related information to the OS. See Links to ACPI-Related Documents under the the heading “Watchdog Descriptor Table (WDDT)”.
“WDRT”	Watchdog Resource Table . Watchdog Timer Hardware Requirements for Windows Server 2003. See Links to ACPI-Related Documents under the heading “Watchdog Timer Resource Table (WDRT)”.
“WPBT”	Windows Platform Binary Table . See Links to ACPI-Related Documents under the heading “Windows Platform Binary Table”.
“WSMT”	Windows Security Mitigations Table . See Links to ACPI-Related Documents under the heading “Windows SMM Security Mitigations Table (WSMT).”
“XENV”	Xen Project . See Links to ACPI-Related Documents under the heading Xen Project Table.

5.2.7 Root System Description Table (RSDT)

OSPM locates that Root System Description Table by following the pointer in the RSDP structure. The RSDT, shown in *Root System Description Table Fields (RSDT)*, starts with the signature ‘RSDT’ followed by an array of physical pointers to other system description tables that provide various information on other standards defined on the current system. OSPM examines each table for a known signature. Based on the signature, OSPM can then interpret the implementation-specific data within the table.

Platforms provide the RSDT to enable compatibility with ACPI 1.0 operating systems. The XSDT, described in the next section, supersedes RSDT functionality.

Table 5.7: Root System Description Table Fields (RSDT)

Field	Byte Length	Byte Offset	Description
Signature	4	0	‘RSDT’ Signature for the Root System Description Table.
Length	4	4	Length, in bytes, of the entire RSDT. The length implies the number of Entry fields (n) at the end of the table.
Revision	1	8	1
Checksum	1	9	Entire table must sum to zero.
OEMID	6	10	OEM ID
OEM Table ID	8	16	For the RSDT, the table ID is the manufacture model ID. This field must match the OEM Table ID in the FADT.
OEM Revision	4	24	OEM revision of RSDT table for supplied OEM Table ID.
Creator ID	4	28	Vendor ID of utility that created the table. For tables containing Definition Blocks, this is the ID for the ASL Compiler.
Creator Revision	4	32	Revision of utility that created the table. For tables containing Definition Blocks, this is the revision for the ASL Compiler.
Entry	4*n	36	An array of 32-bit physical addresses that point to other DESCRIPTION_HEADERS. OSPM assumes at least the DESCRIPTION_HEADER is addressable, and then can further address the table based upon its Length field.

5.2.8 Extended System Description Table (XSDT)

The XSDT provides identical functionality to the RSDT but accommodates physical addresses of DESCRIPTION_HEADERS that are larger than 32 bits. Notice that both the XSDT and the RSDT can be pointed to by the RSDP structure. An ACPI-compatible OS must use the XSDT if present.

Table 5.8: Extended System Description Table Fields (XSDT)

Field	Byte Length	Byte Offset	Description
Signature	4	0	'XSDT'. Signature for the Extended System Description Table.
Length	4	4	Length, in bytes, of the entire table. The length implies the number of Entry fields (n) at the end of the table.
Revision	1	8	1
Checksum	1	9	Entire table must sum to zero.
OEMID	6	10	OEM ID
OEM Table ID	8	16	For the XSDT, the table ID is the manufacture model ID. This field must match the OEM Table ID in the FADT.
OEM Revision	4	24	OEM revision of XSDT table for supplied OEM Table ID.
Creator ID	4	28	Vendor ID of utility that created the table. For tables containing Definition Blocks, this is the ID for the ASL Compiler.
Creator Revision	4	32	Revision of utility that created the table. For tables containing Definition Blocks, this is the revision for the ASL Compiler.
Entry	8*n	36	An array of 64-bit physical addresses that point to other DESCRIPTION_HEADERS. OSPM assumes at least the DESCRIPTION_HEADER is addressable, and then can further address the table based upon its Length field.

5.2.9 Fixed ACPI Description Table (FADT)

The Fixed ACPI Description Table (FADT) defines various fixed hardware ACPI information vital to an ACPI-compatible OS, such as the base address for the following hardware registers blocks: PM1a_EVT_BLK, PM1b_EVT_BLK, PM1a_CNT_BLK, PM1b_CNT_BLK, PM2_CNT_BLK, PM_TMR_BLK, GPE0_BLK, and GPE1_BLK.

The FADT also has a pointer to the DSDT that contains the Differentiated Definition Block, which in turn provides variable information to an ACPI-compatible OS concerning the base system design.

All fields in the FADT that provide hardware addresses provide processor-relative physical addresses.

Note: If the HW_REDUCED_ACPI flag in the table is set, OSPM will ignore fields related to the ACPI HW register interface: Fields at offsets 46 through 108 and 148 through 232, as well as FADT Flag bits 1, 2, 3,7,8,13, 14, 16, and 17).

Note: In all cases where the FADT contains a 32-bit field and a corresponding 64-bit field the 64-bit field should always be preferred by the OSPM if the 64-bit field contains a non-zero value which can be used by the OSPM. In this case, the 32-bit field must be ignored regardless of whether or not it is zero, and whether or not it is the same value as the 64-bit field. The 32-bit field should only be used if the corresponding 64-bit field contains a zero value, or if the 64-bit value can not be used by the OSPM subject to e.g. CPU addressing limitations.

Table 5.9: FADT Format

Field	Byte Length	Byte Offset	Description
Header			
• Signature	4	0	‘FACP’. Signature for the Fixed ACPI Description Table. (This signature predates ACPI 1.0, explaining the mismatch with this table’s name.)
• Length	4	4	Length, in bytes, of the entire FADT.
FADT Major Version	1	8	6 Major Version of this FADT structure, in “Major.Minor” form, where ‘Minor’ is the value in the Minor Version Field (Byte offset 131 in this table) It is the intention that everything contained in the ACPI table would comply with what is contained in the ACPI specification itself. The FADT Major and Minor version follow in lock-step with the version of the ACPI Specification. Conforming to a given ACPI specification means that each and every ACPI-related table conforms to the version number for that table that is listed in that version of the specification.
Checksum	1	9	Entire table must sum to zero.
OEMID	6	10	OEM ID
OEM Table ID	8	16	For the FADT, the table ID is the manufacture model ID. This field must match the OEM Table ID in the RSDT.
OEM Revision	4	24	OEM revision of FADT for supplied OEM Table ID.
Creator ID	4	28	Vendor ID of utility that created the table. For tables containing Definition Blocks, this is the ID for the ASL Compiler.
Creator Revision	4	32	Revision of utility that created the table. For tables containing Definition Blocks, this is the revision for the ASL Compiler.
FIRMWARE_CTRL	4	36	Physical memory address of the FACS, where OSPM and Firmware exchange control information. See Section 5.2.10 for more information about the FACS. If the X_FIRMWARE_CTRL field contains a non zero value which can be used by the OSPM, then this field must be ignored by the OSPM. If the HARDWARE_REDUCED_ACPI flag is set, and both this field and the X_FIRMWARE_CTRL field are zero, there is no FACS available.
DSDT	4	40	Physical memory address of the DSDT. If the X_DSDT field contains a non-zero value which can be used by the OSPM, then this field must be ignored by the OSPM.

continues on next page

Table 5.9 – continued from previous page

<i>Reserved</i>	1	44	ACPI 1.0 defined this offset as a field named INT_MODEL, which was eliminated in ACPI 2.0. Platforms should set this field to zero but field values of one are also allowed to maintain compatibility with ACPI 1.0.
Preferred_PM_Profile	1	45	This field is set by the OEM to convey the preferred power management profile to OSPM. OSPM can use this field to set default power management policy parameters during OS installation. Field Values: 0 Unspecified 1 Desktop 2 Mobile 3 Workstation 4 Enterprise Server 5 SOHO Server 6 Appliance PC 7 Performance Server 8) Tablet >8 Reserved
SCI_INT	2	46	System vector the SCI interrupt is wired to in 8259 mode. On systems that do not contain the 8259, this field contains the Global System interrupt number of the SCI interrupt. OSPM is required to treat the ACPI SCI interrupt as a shareable, level, active low interrupt.
SMI_CMD	4	48	System port address of the SMI Command Port. During ACPI OS initialization, OSPM can determine that the ACPI hardware registers are owned by SMI (by way of the SCI_EN bit), in which case the ACPI OS issues the ACPI_ENABLE command to the SMI_CMD port. The SCI_EN bit effectively tracks the ownership of the ACPI hardware registers. OSPM issues commands to the SMI_CMD port synchronously from the boot processor. This field is reserved and must be zero on system that does not support System Management mode.
ACPI_ENABLE	1	52	The value to write to SMI_CMD to disable SMI ownership of the ACPI hardware registers. The last action SMI does to relinquish ownership is to set the SCI_EN bit. During the OS initialization process, OSPM will synchronously wait for the ntransfer of SMI ownership to complete, so the ACPI system releases SMI ownership as quickly as possible. This field is reserved and must be zero on systems that do not support Legacy Mode.

continues on next page

Table 5.9 – continued from previous page

ACPI_DISABLE	1	53	The value to write to SMI_CMD to re-enable SMI ownership of the ACPI hardware registers. This can only be done when ownership was originally acquired from SMI by OSPM using ACPI_ENABLE. An OS can hand ownership back to SMI by relinquishing use to the ACPI hardware registers, masking off all SCI interrupts, clearing the SCI_EN bit and then writing ACPI_DISABLE to the SMI_CMD port from the boot processor. This field is reserved and must be zero on systems that do not support Legacy Mode.
S4BIOS_REQ	1	54	The value to write to SMI_CMD to enter the S4BIOS state. The S4BIOS state provides an alternate way to enter the S4 state where the firmware saves and restores the memory context. A value of zero in S4BIOS_F indicates S4BIOS_REQ is not supported. (See Section 5.2.10)
PSTATE_CNT	1	55	If non-zero, this field contains the value OSPM writes to the SMI_CMD register to assume processor performance state control responsibility.
PM1a_EVT_BLK	4	56	System port address of the PM1a Event Register Block. See Section 4.8.3.1 for a hardware description layout of this register block. This is a required field. If the X_PM1a_CNT_BLK field contains a non zero value which can be used by the OSPM, then this field must be ignored by the OSPM.
PM1b_EVT_BLK	4	60	System port address of the PM1b Event Register Block. See Section 4.8.3.1 for a hardware description layout of this register block. This field is optional; if this register block is not supported, this field contains zero. If the X_PM1b_EVT_BLK field contains a non zero value which can be used by the OSPM, then this field must be ignored by the OSPM.
PM1a_CNT_BLK	4	64	System port address of the PM1a Control Register Block. See Section 4.8.3.1 for a hardware description layout of this register block. This is a required field. If the X_PM1a_CNT_BLK field contains a non zero value which can be used by the OSPM, then this field must be ignored by the OSPM.
PM1b_CNT_BLK	4	68	System port address of the PM1b Control Register Block. See Section 4.8.3.1 for a hardware description layout of this register block. This field is optional; if this register block is not supported, this field contains zero. If the X_PM1b_CNT_BLK field contains a non zero value which can be used by the OSPM, then this field must be ignored by the OSPM.
PM2_CNT_BLK	4	72	System port address of the PM2 Control Register Block. See Table 4.4 for a hardware description layout of this register block. This field is optional; if this register block is not supported, this field contains zero. If the X_PM2_CNT_BLK field contains a non zero value which can be used by the OSPM, then this field must be ignored by the OSPM.

continues on next page

Table 5.9 – continued from previous page

PM_TMR_BLK	4	76	System port address of the Power Management Timer Control Register Block. See the Section 4.8.3.3 for a hardware description layout of this register block. This is an optional field; if this register block is not supported, this field contains zero. If the X_PM_TMR_BLK field contains a non-zero value which can be used by the OSPM, then this field must be ignored by the OSPM.
GPE0_BLK	4	80	System port address of General-Purpose Event 0 Register Block. See Section 4.8.4.1 for more information. If this register block is not supported, this field contains zero. If the X_GPE0_BLK field contains a nonzero value which can be used by the OSPM, then this field must be ignored by the OSPM.
GPE1_BLK	4	84	System port address of General-Purpose Event 1 Register Block. See Section 4.8.4.1 for more information. This is an optional field; if this register block is not supported, this field contains zero. If the X_GPE1_BLK field contains a nonzero value which can be used by the OSPM, then this field must be ignored by the OSPM.
PM1_EVT_LEN	1	88	Number of bytes decoded by PM1a_EVT_BLK and, if supported, PM1b_EVT_BLK. This value is ≥ 4 .
PM1_CNT_LEN	1	89	Number of bytes decoded by PM1a_CNT_BLK and, if supported, PM1b_CNT_BLK. This value is ≥ 2 .
PM2_CNT_LEN	1	90	Number of bytes decoded by PM2_CNT_BLK. Support for the PM2 register block is optional. If supported, this value is ≥ 1 . If not supported, this field contains zero.
PM_TMR_LEN	1	91	Number of bytes decoded by PM_TMR_BLK. If the PM Timer is supported, this field's value must be 4. If not supported, this field contains zero.
GPE0_BLK_LEN	1	92	The length of the register whose address is given by X_GPE0_BLK (if nonzero) or by GPE0_BLK (otherwise) in bytes. The value is a non-negative multiple of 2.
GPE1_BLK_LEN	1	93	The length of the register whose address is given by X_GPE1_BLK (if nonzero) or by GPE1_BLK (otherwise) in bytes. The value is a non-negative multiple of 2.
GPE1_BASE	1	94	Offset within the ACPI general-purpose event model where GPE1 based events start.
CST_CNT	1	95	If non-zero, this field contains the value OSPM writes to the SMI_CMD register to indicate OS support for the _CST object and C States Changed notification.
P_LVL2_LAT	2	96	The worst-case hardware latency, in microseconds, to enter and exit a C2 state. A value > 100 indicates the system does not support a C2 state.
P_LVL3_LAT	2	98	The worst-case hardware latency, in microseconds, to enter and exit a C3 state. A value > 1000 indicates the system does not support a C3 state.

continues on next page

Table 5.9 – continued from previous page

FLUSH_SIZE	2	100	If WBINVD=0, the value of this field is the number of flush strides that need to be read (using cacheable addresses) to completely flush dirty lines from any processor's memory caches. Notice that the value in FLUSH_STRIDE is typically the smallest cache line width on any of the processor's caches (for more information, see the FLUSH_STRIDE field definition). If the system does not support a method for flushing the processor's caches, then FLUSH_SIZE and WBINVD are set to zero. Notice that this method of flushing the processor caches has limitations, and WBINVD=1 is the preferred way to flush the processors caches. This value is typically at least 2 times the cache size. The maximum allowed value for FLUSH_SIZE multiplied by FLUSH_STRIDE is 2 MB for a typical maximum supported cache size of 1 MB. Larger cache sizes are supported using WBINVD=1. This value is ignored if WBINVD=1. This field is maintained for ACPI 1.0 processor compatibility on existing systems. Processors in new ACPI-compatible systems are required to support the WBINVD function and indicate this to OSPM by setting the WBINVD field = 1.
FLUSH_STRIDE	2	102	If WBINVD=0, the value of this field is the cache line width, in bytes, of the processor's memory caches. This value is typically the smallest cache line width on any of the processor's caches. For more information, see the description of the FLUSH_SIZE field. This value is ignored if WBINVD=1. This field is maintained for ACPI 1.0 processor compatibility on existing systems. Processors in new ACPI-compatible systems are required to support the WBINVD function and indicate this to OSPM by setting the WBINVD field = 1.
DUTY_OFFSET	1	104	The zero-based index of where the processor's duty cycle setting is within the processor's P_CNT register.
DUTY_WIDTH	1	105	The bit width of the processor's duty cycle setting value in the P_CNT register. Each processor's duty cycle setting allows the software to select a nominal processor frequency below its absolute frequency as defined by: $THTL_EN = 1 \text{ BF} * DC / (2 \text{ DUTY_WIDTH})$ Where: BF-Base frequency DC-Duty cycle setting When THTL_EN is 0, the processor runs at its absolute BF. A DUTY_WIDTH value of 0 indicates that processor duty cycle is not supported and the processor continuously runs at its base frequency.
DAY_ALARM	1	106	The RTC CMOS RAM index to the day-of-month alarm value. If this field contains a zero, then the RTC day of the month alarm feature is not supported. If this field has a non-zero value, then this field contains an index into RTC RAM space that OSPM can use to program the day of the month alarm. See Section 4.8.2.4 for a description of how this hardware works.

continues on next page

Table 5.9 – continued from previous page

MON_ALARM	1	107	The RTC CMOS RAM index to the month of year alarm value. If this field contains a zero, then the RTC month of the year alarm feature is not supported. If this field has a non-zero value, then this field contains an index into RTC RAM space that OSPM can use to program the month of the year alarm. If this feature is supported, then the DAY_ALARM feature must be supported also.
CENTURY	1	108	The RTC CMOS RAM index to the century of data value (hundred and thousand year decimals). If this field contains a zero, then the RTC centenary feature is not supported. If this field has a non-zero value, then this field contains an index into RTC RAM space that OSPM can use to program the centenary field.
IAPC_BOOT_ARCH	2	109	IA-PC Boot Architecture Flags. See Section 5.2.9.3 for a description of this field.
<i>Reserved</i>	1	111	Must be 0.
Flags	4	112	Fixed feature flags. See Table 5.10 for a description of this field.
RESET_REG	12	116	The address of the reset register represented in Generic Address Structure format (See Section 4.8.3.6 for a description of the reset mechanism.) Note: Only System I/O space, System Memory space and PCI Configuration space (bus #0) are valid for values for Address_Space_ID. Also, Register_Bit_Width must be 8 and Register_Bit_Offset must be 0.
RESET_VALUE	1	128	Indicates the value to write to the RESET_REG port to reset the system. (See Section 4.8.3.6 for a description of the reset mechanism.)
ARM_BOOT_ARCH	2	129	ARM Boot Architecture Flags. See Table 5.12 for a description of this field.
FADT Minor Version	1	131	5.0 (errata bits 4-7 = 0) Minor Version of this FADT structure, in “Major.Minor” form, where ‘Major’ is the value in the Major Version Field (Byte offset 8 in this table). Bits 0-3 - The low order bits correspond to the minor version of the specification version. For instance, ACPI 6.3 has a major version of 6, and a minor version of 3. Bits 4-7 - The high order bits correspond to the version of the ACPI Specification errata this table complies with. A value of 0 means that it complies with the base version of the current specification. A value of 1 means this is compatible with Errata A, 2 would be compatible with Errata B, and so on.
X_FIRMWARE_CTRL	8	132	Extended physical address of the FACS. If this field contains a nonzero value which can be used by the OSPM, then the FIRMWARE_CTRL field must be ignored by the OSPM. If the HARDWARE_REDUCED_ACPI flag is set, and both this field and the FIRMWARE_CTRL field are zero, there is no FACS available.

continues on next page

Table 5.9 – continued from previous page

X_DSDT	8	140	Extended physical address of the DSDT. If this field contains a nonzero value which can be used by the OSPM, then the DSDT field must be ignored by the OSPM.
X_PM1a_EVT_BLK	12	148	Extended address of the PM1a Event Register Block, represented in Generic Address Structure format. See Section 4.8.3.1 for a hardware description layout of this register block. This is a required field. If this field contains a nonzero value which can be used by the OSPM, then the PM1a_EVT_BLK field must be ignored by the OSPM.
X_PM1b_EVT_BLK	12	160	Extended address of the PM1b Event Register Block, represented in Generic Address Structure format. See Section 4.8.3.1 for a hardware description layout of this register block. This field is optional; if this register block is not supported, this field contains zero. If this field contains a nonzero value which can be used by the OSPM, then the PM1b_EVT_BLK field must be ignored by the OSPM.
X_PM1a_CNT_BLK	12	172	Extended address of the PM1a Control Register Block, represented in Generic Address Structure format. See Section 4.8.3.2 for a hardware description layout of this register block. This is a required field. If this field contains a nonzero value which can be used by the OSPM, then the PM1a_CNT_BLK field must be ignored by the OSPM.
X_PM1b_CNT_BLK	12	184	Extended address of the PM1b Control Register Block, represented in Generic Address Structure format. See Section 4.8.3.2 for a hardware description layout of this register block. This field is optional; if this register block is not supported, this field contains zero. If this field contains a nonzero value which can be used by the OSPM, then the PM1b_CNT_BLK field must be ignored by the OSPM.
X_PM2_CNT_BLK	12	196	Extended address of the PM2 Control Register Block, represented in Generic Address Structure format. See PM2 Control (PM2_CNT) for a hardware description layout of this register block. This field is optional; if this register block is not supported, this field contains zero. If this field contains a nonzero value which can be used by the OSPM, then the PM2_CNT_BLK field must be ignored by the OSPM.
X_PM_TMR_BLK	12	208	Extended address of the Power Management Timer Control Register Block, represented in Generic Address Structure format. See Section 4.8.3.3 for a hardware description layout of this register block. This field is optional; if this register block is not supported, this field contains zero. If this field contains a nonzero value which can be used by the OSPM, then the PM_TMR_BLK field must be ignored by the OSPM.

continues on next page

Table 5.9 – continued from previous page

X_GPE0_BLK	12	220	Extended address of the General-Purpose Event 0 Register Block, represented in Generic Address Structure format. See Section 4.8.4.1 for more information. This is an optional field; if this register block is not supported, this field contains zero. If this field contains a nonzero value which can be used by the OSPM, then the GPE0_BLK field must be ignored by the OSPM. Note: Only System I/O space and System Memory space are valid for Address_Space_ID values, and the OSPM ignores Register_Bit_Width, Register_Bit_Offset and Access_Size.
X_GPE1_BLK	12	232	Extended address of the General-Purpose Event 1 Register Block, represented in Generic Address Structure format. See Section 4.8.4.1 for more information. This is an optional field; if this register block is not supported, this field contains zero. If this field contains a nonzero value which can be used by the OSPM, then the GPE1_BLK field must be ignored by the OSPM. Note: Only System I/O space and System Memory space are valid for Address_Space_ID values, and the OSPM ignores Register_Bit_Width, Register_Bit_Offset and Access_Size.
SLEEP_CONTROL_REG	12	244	The address of the Sleep register, represented in Generic Address Structure format (see Section 4.8.3.7 for a description of the sleep mechanism). Note: Only System I/O space, System Memory space and PCI Configuration space (bus #0) are valid for values for Address_Space_ID. Also, Register_Bit_Width must be 8 and Register_Bit_Offset must be 0.
SLEEP_STATUS_REG	12	256	The address of the Sleep status register, represented in Generic Address Structure format (see Section 4.8.3.7 for a description of the sleep mechanism). Note: Only System I/O space, System Memory space and PCI Configuration space (bus #0) are valid for values for Address_Space_ID. Also, Register_Bit_Width must be 8 and Register_Bit_Offset must be 0.
Hypervisor Vendor Identity	8	268	64-bit identifier of hypervisor vendor. All bytes in this field are considered part of the vendor identity. These identifiers are defined independently by the vendors themselves, usually following the name of the hypervisor product. Version information should NOT be included in this field - this shall simply denote the vendor's name or identifier. Version information can be communicated through a supplemental vendor-specific hypervisor API. Firmware implementers would place zero bytes into this field, denoting that no hypervisor is present in the actual firmware.

Note: [Hypervisor Vendor Identity] A firmware implementer would place zero bytes into this field, denoting that no hypervisor is present in the actual firmware.

Note: [Hypervisor Vendor Identity] A hypervisor vendor that presents ACPI tables of its own construction to a guest (for ‘virtual’ firmware or its ‘virtual’ platform), would provide its identity in this field.

Note: [Hypervisor Vendor Identity] If a guest operating system is aware of this field it can consult it and act on the result, based on whether it recognized the vendor and knows how to use the API that is defined by the vendor.

Table 5.10: Fixed ACPI Description Table Fixed Feature Flags

FACP - Flag	Bit Length	Bit Off-set	Description
WBINVD	1	0	Processor properly implements a functional equivalent to the WBINVD IA-32 instruction. If set, signifies that the WBINVD instruction correctly flushes the processor caches, maintains memory coherency, and upon completion of the instruction, all caches for the current processor contain no cached data other than what OSPM references and allows to be cached. If this flag is not set, the ACPI OS is responsible for disabling all ACPI features that need this function. This field is maintained for ACPI 1.0 processor compatibility on existing systems. Processors in new ACPI-compatible systems are required to support this function and indicate this to OSPM by setting this field.
WBINVD_FLUSH	1	1	If set, indicates that the hardware flushes all caches on the WBINVD instruction and maintains memory coherency, but does not guarantee the caches are invalidated. This provides the complete semantics of the WBINVD instruction, and provides enough to support the system sleeping states. If neither of the WBINVD flags is set, the system will require FLUSH_SIZE and FLUSH_STRIDE to support sleeping states. If the FLUSH parameters are also not supported, the machine cannot support sleeping states S1, S2, or S3.
PROC_C1	1	2	A one indicates that the C1 power state is supported on all processors.
P_LVL2_UP	1	3	A zero indicates that the C2 power state is configured to only work on a uniprocessor (UP) system. A one indicates that the C2 power state is configured to work on a UP or multiprocessor (MP) system.

continues on next page

Table 5.10 – continued from previous page

PWR_BUTTON	1	4	A zero indicates the power button is handled as a fixed feature programming model; a one indicates the power button is handled as a control method device. If the system does not have a power button, this value would be “1” and no power button device would be present. Independent of the value of this field, the presence of a power button device in the namespace indicates to OSPM that the power button is handled as a control method device.
SLP_BUTTON	1	5	A zero indicates the sleep button is handled as a fixed feature programming model; a one indicates the sleep button is handled as a control method device. If the system does not have a sleep button, this value would be “1” and no sleep button device would be present. Independent of the value of this field, the presence of a sleep button device in the namespace indicates to OSPM that the sleep button is handled as a control method device.
FIX_RTC	1	6	A zero indicates the RTC wake status is supported in fixed register space; a one indicates the RTC wake status is not supported in fixed register space.
RTC_S4	1	7	Indicates whether the RTC alarm function can wake the system from the S4 state. The RTC must be able to wake the system from an S1, S2, or S3 sleep state. The RTC alarm can optionally support waking the system from the S4 state, as indicated by this value.
TMR_VAL_EXT	1	8	A zero indicates TMR_VAL is implemented as a 24-bit value. A one indicates TMR_VAL is implemented as a 32-bit value. The TMR_STS bit is set when the most significant bit of the TMR_VAL toggles.
DCK_CAP	1	9	A zero indicates that the system cannot support docking. A one indicates that the system can support docking. Notice that this flag does not indicate whether or not a docking station is currently present; it only indicates that the system is capable of docking.
RESET_REG_SUP	1	10	If set, indicates the system supports system reset via the FADT RESET_REG as described in Section 4.8.3.6 .
SEALED_CASE	1	11	System Type Attribute. If set indicates that the system has no internal expansion capabilities and the case is sealed.
HEADLESS	1	12	System Type Attribute. If set indicates the system cannot detect the monitor or keyboard / mouse devices.

continues on next page

Table 5.10 – continued from previous page

CPU_SW_SLP	1	13	If set, indicates to OSPM that a processor native instruction must be executed after writing the SLP_TYPx register.
PCI_EXP_WAK	1	14	If set, indicates the platform supports the PCI_EXP_WAKE_STS bit in the PM1 Status register and the PCIEXP_WAKE_EN bit in the PM1 Enable register. This bit must be set on platforms containing chipsets that implement PCI Express and supports PM1 PCIEXP_WAK bits.
USE_PLATFORM_CLOCK	1	15	A value of one indicates that OSPM should use a platform provided timer to drive any monotonically non-decreasing counters, such as OSPM performance counter services. Which particular platform timer will be used is OSPM specific, however, it is recommended that the timer used is based on the following algorithm: If the HPET is exposed to OSPM, OSPM should use the HPET. Otherwise, OSPM will use the ACPI power management timer. A value of one indicates that the platform is known to have a correctly implemented ACPI power management timer. A platform may choose to set this flag if an internal processor clock (or clocks in a multi-processor configuration) cannot provide consistent monotonically non-decreasing counters. Note: If a value of zero is present, OSPM may arbitrarily choose to use an internal processor clock or a platform timer clock for these operations. That is, a zero does not imply that OSPM will necessarily use the internal processor clock to generate a monotonically non-decreasing counter to the system.
S4_RTC_STS_VALID	1	16	A one indicates that the contents of the RTC_STS flag is valid when waking the system from S4. See Table 4.11 for more information. Some existing systems do not reliably set this input today, and this bit allows OSPM to differentiate correctly functioning platforms from platforms with this errata.
REMOTE_POWER_ON_CAPABLE	1	17	A one indicates that the platform is compatible with remote power-on. That is, the platform supports OSPM leaving GPE wake events armed prior to an S5 transition. Some existing platforms do not reliably transition to S5 with wake events enabled (for example, the platform may immediately generate a spurious wake event after completing the S5 transition). This flag allows OSPM to differentiate correctly functioning platforms from platforms with this type of errata.

continues on next page

Table 5.10 – continued from previous page

FORCE_APIC_CLUSTER_MODEL	1	18	A one indicates that all local APICs must be configured for the cluster destination model when delivering interrupts in logical mode. If this bit is set, then logical mode interrupt delivery operation may be undefined until OSPM has moved all local APICs to the cluster model. Note that the cluster destination model doesn't apply to Itanium™ Processor Family (IPF) local SAPICs. This bit is intended for xAPIC based machines that require the cluster destination model even when 8 or fewer local APICs are present in the machine.
FORCE_APIC_PHYSICAL_DESTINATION_MODE	1	19	A one indicates that all local xAPICs must be configured for physical destination mode. If this bit is set, interrupt delivery operation in logical destination mode is undefined. On machines that contain fewer than 8 local xAPICs or that do not use the xAPIC architecture, this bit is ignored.
HW_REDUCED_ACPI *	1	20	A one indicates that the Hardware-Reduced ACPI (section 4.1) is implemented, therefore software-only alternatives are used for supported fixed-features defined in chapter 4.
LOW_POWER_S0_IDLE_CAPABLE	1	21	A one informs OSPM that the platform is able to achieve power savings in S0 similar to or better than those typically achieved in S3. In effect, when this bit is set it indicates that the system will achieve no power benefit by making a sleep transition to S3.

continues on next page

Table 5.10 – continued from previous page

PERSISTENT_CPU_CACHES	2	22	<p>The following values describe whether cpu caches and any other caches that are coherent with them, are considered by the platform to be persistent. The platform evaluates the configuration present at system startup to determine this value. System configuration changes after system startup may invalidate this.</p> <p>00b - Not reported by the platform. Software should reference the NFIT Platform Capabilities</p> <p>01b - Cpu caches and any other caches that are coherent with them, are not persistent. Software is responsible for flushing data from cpu caches to make stores persistent. Supersedes NFIT Platform Capabilities.</p> <p>10b - Cpu caches and any other caches that are coherent with them, are persistent. Supersedes NFIT Platform Capabilities. When reporting this state, the platform shall provide enough stored energy for ALL of the following:</p> <ul style="list-style-type: none"> - Time to flush cpu caches and any other caches that are coherent with them - Time of all targets of those flushes to complete flushing stored data - If supporting hot plug, the worst case CXL device topology that can be hot plugged <p>11b - Reserved</p>
<i>Reserved</i>	8	24	

* The description of HW_REDUCED_ACPI provided here applies to ACPI specifications 5.0 and later.

5.2.9.1 Preferred PM Profile System Types

The following descriptions of preferred power management profile system types are to be used as a guide for setting the Preferred_PM_Profile field in the FADT. OSPM can use this field to set default power management policy parameters during OS installation.

Desktop A single user, full featured, stationary computing device that resides on or near an individual’s work area. Most often contains one processor. Must be connected to AC power to function. This device is used to perform work that is considered mainstream corporate or home computing (for example, word processing, Internet browsing, spreadsheets, and so on).

Mobile A single-user, full-featured, portable computing device that is capable of running on batteries or other power storage devices to perform its normal functions. Most often contains one processor. This device performs the same task set as a desktop. However it may have limitations dues to its size, thermal requirements, and/or power source life.

Workstation A single-user, full-featured, stationary computing device that resides on or near an individual’s work area. Often contains more than one processor. Must be connected to AC power to function. This device is used to perform large quantities of computations in support of such work as CAD/CAM and other graphics-intensive applications.

Enterprise Server A multi-user, stationary computing device that frequently resides in a separate, often specially designed, room. Will almost always contain more than one processor. Must be connected to AC power to function. This device is used to support large-scale networking, database, communications, or financial operations within a corporation or government.

SOHO Server A multi-user, stationary computing device that frequently resides in a separate area or room in a small or home office. May contain more than one processor. Must be connected to AC power to function. This device is generally used to support all of the networking, database, communications, and financial operations of a small office or home office.

Appliance PC A device specifically designed to operate in a low-noise, high-availability environment such as a consumer's living rooms or family room. Most often contains one processor. This category also includes home Internet gateways, Web pads, set top boxes and other devices that support ACPI. Must be connected to AC power to function. Normally they are sealed case style and may only perform a subset of the tasks normally associated with today's personal computers.

Performance Server A multi-user stationary computing device that frequently resides in a separate, often specially designed room. Will often contain more than one processor. Must be connected to AC power to function. This device is used in an environment where power savings features are willing to be sacrificed for better performance and quicker responsiveness.

Tablet A full-featured, highly mobile computing device which resembles writing tablets and which users interact with primarily through a touch interface. The touch digitizer is the primary user input device, although a keyboard and/or mouse may be present. Tablet devices typically run on battery power and are generally only plugged into AC power in order to charge. This device performs many of the same tasks as Mobile; however battery life expectations of Tablet devices generally require more aggressive power savings especially for managing display and touch components.

5.2.9.2 System Type Attributes

This set of flags is used by the OS to assist in determining assumptions about power and device management. These flags are read at boot time and are used to make decisions about power management and device settings. For example, a system that has the SEALED_CASE bit set may take a very aggressive low noise policy toward thermal management. In another example an OS might not load video, keyboard or mouse drivers on a HEADLESS system.

5.2.9.3 IA-PC Boot Architecture Flags

This set of flags is used by an OS to guide the assumptions it can make in initializing hardware on IA-PC platforms. These flags are used by an OS at boot time (before the OS is capable of providing an operating environment suitable for parsing the ACPI namespace) to determine the code paths to take during boot. In IA-PC platforms with reduced legacy hardware, the OS can skip code paths for legacy devices if none are present. For example, if there are no ISA devices, an OS could skip code that assumes the presence of these devices and their associated resources. These flags are used independently of the ACPI namespace. The presence of other devices must be described in the ACPI namespace as specified in [Section 6](#) These flags pertain only to IA-PC platforms. On other system architectures, the entire field should be set to 0.

Table 5.11: Fixed ACPI Description Table Boot IA-PC Boot

IAPC_BOOT_ARCH	Bit length	Bit offset	Description
LEGACY_DEVICES	1	0	If set, indicates that the motherboard supports user-visible devices on the LPC or ISA bus. User-visible devices are devices that have end-user accessible connectors (for example, LPT port), or devices for which the OS must load a device driver so that an end-user application can use a device. If clear, the OS may assume there are no such devices and that all devices in the system can be detected exclusively via industry standard device enumeration mechanisms (including the ACPI namespace).
8042	1	1	If set, indicates that the motherboard contains support for a port 60 and 64 based keyboard controller, usually implemented as an 8042 or equivalent micro-controller.
VGA Not Present	1	2	If set, indicates to OSPM that it must not blindly probe the VGA hardware (that responds to MMIO addresses A0000h-BFFFFh and IO ports 3B0h-3BBh and 3C0h-3DFh) that may cause machine check on this system. If clear, indicates to OSPM that it is safe to probe the VGA hardware.
MSI Not Supported	1	3	If set, indicates to OSPM that it must not enable Message Signaled Interrupts (MSI) on this platform.
PCIe ASPM Controls	1	4	If set, indicates to OSPM that it must not enable OSPM ASPM control on this platform.
CMOS RTC Not Present	1	5	If set, indicates that the CMOS RTC is either not implemented, or does not exist at the legacy addresses. OSPM uses the Control Method Time and Alarm Namespace device instead.
<i>Reserved</i>	10	6	Must be 0.

5.2.9.4 ARM Architecture Boot Flags

These flags are used by an OS at boot time (before the OS is capable of providing an operating environment suitable for parsing the ACPI namespace) to determine the code paths to take during boot. For the PSCI flags, specifically, the flags describe if the platform is compliant with the PSCI specification. A link to the PSCI specification can be found at “Links to ACPI-Related Documents” at <http://uefi.org/acpi>.

The ARM Architecture boot flags are described in the following table.

Table 5.12: Fixed ACPI Description Table ARM Boot Architecture Flags

ARM_BOOT_ARCH	Bit Length	Bit Off-set	Description
PSCI_COMPLIANT	1	0	1 if PSCI is implemented.
PSCI_USE_HVC	1	1	1 if HVC must be used as the PSCI conduit instead of SMC.
Reserved	14	2	This value is zero.

5.2.10 Firmware ACPI Control Structure (FACS)

The Firmware ACPI Control Structure (FACS) is a structure in read/write memory that the platform boot firmware reserves for ACPI usage. This structure is optional if and only if the `HARDWARE_REDUCED_ACPI` flag in the FADT is set. The FACS is passed to an ACPI-compatible OS using the FADT. For more information about the FADT `FIRMWARE_CTRL` field, see [Section 5.2.9](#)

The platform boot firmware aligns the FACS on a 64-byte boundary anywhere within the system's memory address space. The memory where the FACS structure resides must not be reported as system `AddressRangeMemory` in the system address map. For example, the E820 address map reporting interface would report the region as `AddressRangeReserved`. For more information, see [Section 15](#).

Table 5.13: Firmware ACPI Control Structure (FACS)

Field	Byte Length	Byte Offset	Description
Signature	4	0	'FACS'
Length	4	4	Length, in bytes, of the entire Firmware ACPI Control Structure. This value is 64 bytes or larger.
Hardware Signature	4	8	The value of the system's "hardware signature at current boot." The only thing that determines the hardware signature is the ACPI tables. If any content or structure of the ACPI tables has changed, including adding or removing of tables, then the hardware signature must change.
Firmware Waking Vector	4	12	This field is superseded by the <code>X_Firmware_Waking_Vector</code> field. The 32-bit address field where OSPM puts its waking vector. Before transitioning the system into a global sleeping state, OSPM fills in this field with the physical memory address of an OS-specific wake function. During POST, the platform firmware first checks if the value of the <code>X_Firmware_Waking_Vector</code> field is non-zero and if so transfers control to OSPM as outlined in the <code>X_Firmware_Waking_vector</code> field description below. If the <code>X_Firmware_Waking_Vector</code> field is zero then the platform firmware checks the value of this field and if it is non-zero, transfers control to the specified address. On PCs, the wake function address is in memory below 1 MB and the control is transferred while in real mode. OSPM's wake function restores the processors' context. For IA-PC platforms, the following example shows the relationship between the physical address in the Firmware Waking Vector and the real mode address the BIOS jumps to. If, for example, the physical address is 0x12345, then the BIOS must jump to real mode address 0x1234:0x0005. In general this relationship is $\text{Real-mode address} = \text{Physical address} \gg 4 : \text{Physical address}$ and 0x000F. Notice that on IA-PC platforms, A20 must be enabled when the BIOS jumps to the real mode address derived from the physical address stored in the Firmware Waking Vector.

continues on next page

Table 5.13 – continued from previous page

Field	Byte Length	Byte Offset	Description
Global Lock	4	16	This field contains the Global Lock used to synchronize access to shared hardware resources between the OSPM environment and an external controller environment (for example, the SMI environment). This lock is owned exclusively by either OSPM or the firmware at any one time. When ownership of the lock is attempted, it might be busy, in which case the requesting environment exits and waits for the signal that the lock has been released. For example, the Global Lock can be used to protect an embedded controller interface such that only OSPM or the firmware will access the embedded controller interface at any one time. See Section 5.2.10.1 for more information on acquiring and releasing the Global Lock.
Flags	4	20	Table 5.14
X Firmware Waking Vector	8	24	64-bit physical address of OSPM’s Waking Vector. Before transitioning the system into a global sleeping state, OSPM fills in this field and the OSPM Flags field to describe the waking vector. OSPM populates this field with the physical memory address of an OS-specific wake function. During POST, the platform firmware checks if the value of this field is non-zero and if so transfers control to OSPM by jumping to this address after creating the appropriate execution environment, which must be configured as follows: For 64-bit Itanium™ Processor Family (IPF) -based platforms: Interrupts must be disabled The processor must have psr.i set to 0. See the Intel® Itanium™ Architecture Software Developer’s Manual for more information. Memory address translation must be disabled The processor must have psr.it, psr.dt, and psr.rt set to 0. See the Intel® Itanium™ Architecture Software Developer’s Manual for more information. For IA 32 and x64 platforms, platform firmware is required to support a 32 bit execution environment. Platform firmware can additionally support a 64 bit execution environment. If platform firmware supports a 64 bit execution environment, firmware inspects the OSPM Flags during POST. If the 64BIT_WAKE_F flag is set, the platform firmware creates a 64 bit execution environment. Otherwise, the platform firmware creates a 32 bit execution environment. For 64 bit execution environment: Interrupts must be disabled EFLAGS.IF set to 0 Long mode enabled Paging mode is enabled and physical memory for waking vector is identity mapped (virtual address equals physical address) Waking vector must be contained within one physical page Selectors are set to be flat and are otherwise not used For 32 bit execution environment: Interrupts must be disabled EFLAGS.IF set to 0 Memory address translation / paging must be disabled 4 GB flat address space for all segment registers

continues on next page

Table 5.13 – continued from previous page

Field	Byte Length	Byte Offset	Description
Version	1	32	3-Version of this table
<i>Reserved</i>	3	33	This value is zero.
OSPM Flags	4	36	OSPM enabled firmware control structure flags. Platform firmware must initialize this field to zero. See Table 5.15 for more details.
<i>Reserved</i>	24	40	This value is zero.

Table 5.14: Firmware Control Structure Feature Flags

FACS - Flag	Bit Length	Bit Offset	Description
S4BIOS_F	1	0	Indicates whether the platform supports S4BIOS_REQ. If S4BIOS_REQ is not supported, OSPM must be able to save and restore the memory state in order to use the S4 state.
64BIT_WAKE_SUPPORTED_F	1	1	Indicates that the platform firmware supports a 64 bit execution environment for the waking vector. When set and the OSPM additionally set 64BIT_WAKE_F, the platform firmware will create a 64 bit execution environment before transferring control to the X_Firmware_Waking_Vector.
<i>Reserved</i>	30	2	The value is zero.

Table 5.15: OSPM Enabled Firmware Control Structure Feature Flags

FACS - Flag	Bit Length	Bit Offset	Description
64BIT_WAKE_F	1	0	OSPM sets this bit to indicate to platform firmware that the X_Firmware_Waking_Vector requires a 64 bit execution environment. This flag can only be set if platform firmware sets 64BIT_WAKE_SUPPORTED_F in the FACS flags field. This bit field has no affect on Itanium™ Processor Family (IPF) -based platforms, which require a 64 bit execution environment.
<i>Reserved</i>	31	1	The value is zero.

5.2.10.1 Global Lock

The purpose of the ACPI Global Lock is to provide mutual exclusion between the host OS and the platform runtime firmware. The Global Lock is a 32-bit (DWORD) value in read/write memory located within the FACS and is accessed and updated by both the OS environment and the SMI environment in a defined manner to provide an exclusive lock. Note: this is not a pointer to the Global Lock, it is the actual memory location of the lock. The FACS and Global Lock may be located anywhere in physical memory.

By convention, this lock is used to ensure that while one environment is accessing some hardware, the other environment is not. By this convention, when ownership of the lock fails because the other environment owns it, the requesting environment sets a “pending” state within the lock, exits its attempt to acquire the lock, and waits for the owning environment to signal that the lock has been released before attempting to acquire the lock again. When releasing the lock, if the pending bit in the lock is set after the lock is released, a signal is sent via an interrupt mechanism to the

other environment to inform it that the lock has been released. During interrupt handling for the “lock released” event within the corresponding environment, if the lock ownership were still desired an attempt to acquire the lock would be made. If ownership is not acquired, then the environment must again set “pending” and wait for another “lock release” signal.

The table below shows the encoding of the Global Lock DWORD in memory.

Table 5.16: Global Lock Structure within the FACS

Field	Bit Length	Bit Off-set	Description
Pending	1	0	Non-zero indicates that a request for ownership of the Global Lock is pending.
Owned	1	1	Non-zero indicates that the Global Lock is Owned.
<i>Reserved</i>	30	2	Reserved for future use.

The following code sequence is used by both OSPM and the firmware to acquire ownership of the Global Lock. If non-zero is returned by the function, the caller has been granted ownership of the Global Lock and can proceed. If zero is returned by the function, the caller has not been granted ownership of the Global Lock, the “pending” bit has been set, and the caller must wait until it is signaled by an interrupt event that the lock is available before attempting to acquire access again.

Note: In the examples that follow, the “GlobalLock” variable is a pointer that has been previously initialized to point to the 32-bit Global Lock location within the FACS.

```

AcquireGlobalLock:
    mov ecx, GlobalLock           ; ecx = Address of Global Lock in FACS
acq10:  mov eax, [ecx]             ; Get current value of Global Lock

    mov edx, eax
    and edx, not 1               ; Clear pending bit
    bts edx, 1                   ; Check and set owner bit
    adc edx, 0                   ; If owned, set pending bit

    lock cmpxchg dword ptr[ecx], edx ; Attempt to set new value
    jnz short acq10             ; If not set, try again

    cmp dl, 3                    ; Was it acquired or marked pending?
    sbb eax, eax                 ; acquired = -1, pending = 0

    ret
    
```

The following code sequence is used by OSPM and the firmware to release ownership of the Global Lock. If non-zero is returned, the caller must raise the appropriate event to the other environment to signal that the Global Lock is now free. Depending on the environment, this signaling is done by setting the either the GBL_RLS or BIOS_RLS within their respective hardware register spaces. This signal only occurs when the other environment attempted to acquire ownership while the lock was owned.

```

ReleaseGlobalLock:
    mov ecx, GlobalLock           ; ecx = Address of Global Lock in FACS
rel10:  mov eax, [ecx]             ; Get current value of Global Lock

    mov edx, eax
    and edx, not 03h             ; Clear owner and pending field
    
```

(continues on next page)

(continued from previous page)

```

lock cmpxchg dword ptr[ecx], edx      ; Attempt to set it
jnz short rel10                       ; If not set, try again

and eax, 1                            ; Was pending set?

; if one is returned (we were pending) the caller must signal that the
; lock has been released using either GBL_RLS or BIOS_RLS as appropriate

ret

```

Although using the Global Lock allows various hardware resources to be shared, it is important to notice that its usage when there is ownership contention could entail a significant amount of system overhead as well as waits of an indeterminate amount of time to acquire ownership of the Global Lock. For this reason, implementations should try to design the hardware to keep the required usage of the Global Lock to a minimum.

The Global Lock is required whenever a logical register in the hardware is shared. For example, if bit 0 is used by ACPI (OSPM) and bit 1 of the same register is used by SMI, then access to that register needs to be protected under the Global Lock, ensuring that the register's contents do not change from underneath one environment while the other is making changes to it. Similarly if the entire register is shared, as the case might be for the embedded controller interface, access to the register needs to be protected under the Global Lock.

5.2.11 Definition Blocks

A Definition Block consists of data in AML format (see [Section 5.4](#) “Definition Block Encoding”) and contains information about hardware implementation details in the form of AML objects that contain data, AML code, or other AML objects. The top-level organization of this information after a definition block is loaded is name-tagged in a hierarchical namespace.

OSPM “loads” or “unloads” an entire definition block as a logical unit. OSPM will load a definition block either as a result of executing the AML Load() or LoadTable() operator or encountering a table definition during initialization. During initialization, OSPM loads the Differentiated System Description Table (DSDT), which contains the Differentiated Definition Block, using the DSDT pointer retrieved from the FADT. OSPM will load other definition blocks during initialization as a result of encountering Secondary System Description Table (SSDT) definitions in the RSDT/XSDT. Each SSDT must be loaded in the order presented in the RSDT/XSDT. The DSDT and SSDT are described in the following sections.

As mentioned, the AML Load() and LoadTable() operators make it possible for a Definition Block to load other Definition Blocks, either statically or dynamically, where they in turn can either define new system attributes or, in some cases, build on prior definitions. Although this gives the hardware the ability to vary widely in implementation, it also confines it to reasonable boundaries. In some cases, the Definition Block format can describe only specific and well-understood variances. In other cases, it permits implementations to be expressible only by means of a specified set of “built in” operators. For example, the Definition Block has built in operators for I/O space.

In theory, it might be possible to define something like PCI configuration space in a Definition Block by building it from I/O space, but that is not the goal of the definition block. Such a space is usually defined as a “built in” operator.

Some AML operators perform simple functions, and others encompass complex functions. The power of the Definition block comes from its ability to allow these operations to be glued together in numerous ways, to provide functionality to OSPM.

The AML operators defined in this specification are intended to allow many useful hardware designs to be easily expressed, not to allow all hardware designs to be expressed.

Note: To accommodate addressing beyond 32 bits, the integer type was expanded to 64 bits in ACPI 2.0, see [Section 19.3.5](#). Existing ACPI definition block implementations may contain an inherent assumption of a 32-bit integer width. Therefore, to maintain backwards compatibility, OSPM uses the Revision field, in the header portion of system

description tables containing Definition Blocks, to determine whether integers declared within the Definition Block are to be evaluated as 32-bit or 64-bit values. A Revision field value greater than or equal to 2 signifies that integers declared within the Definition Block are to be evaluated as 64-bit values. The ASL writer specifies the value for the Definition Block table header's Revision field via the ASL Definition Block's ComplianceRevision field. See [Section 19.6.29](#), for more information. It is the responsibility of the ASL writer to ensure the Definition Block's compatibility with the corresponding integer width when setting the ComplianceRevision field.

5.2.11.1 Differentiated System Description Table (DSDT)

The Differentiated System Description Table (DSDT) is part of the system fixed description. The DSDT is comprised of a system description table header followed by data in Definition Block format. See [Section 5.2.11](#) for a description of Definition Blocks. During initialization, OSPM finds the pointer to the DSDT in the Fixed ACPI Description Table (using the FADT's DSDT or X_DSDT fields) and then loads the DSDT to create the ACPI Namespace.

Table 5.17: Differentiated System Description Table Fields (DSDT)

Field	Byte Length	Byte Offset	Description
Signature	4	0	'DSDT' Signature for the Differentiated System Description Table.
Length	4	4	Length, in bytes, of the entire DSDT (including the header).
Revision	1	8	2. This field also sets the global integer width for the AML interpreter. Values less than two will cause the interpreter to use 32-bit integers and math. Values of two and greater will cause the interpreter to use full 64-bit integers and math.
Checksum	1	9	Entire table must sum to zero.
OEMID	6	10	OEM ID
OEM Table ID	8	16	The manufacture model ID.
OEM Revision	4	24	OEM revision of DSDT for supplied OEM Table ID.
Creator ID	4	28	Vendor ID for the ASL Compiler.
Creator Revision	4	32	Revision number of the ASL Compiler.
Definition Block	n	36	n bytes of AML code (see Section 5.4).

5.2.11.2 Secondary System Description Table (SSDT)

Secondary System Description Tables (SSDT) are a continuation of the DSDT. The SSDT is comprised of a system description table header followed by data in Definition Block format. There can be multiple SSDTs present. After OSPM loads the DSDT to create the ACPI Namespace, each secondary system description table listed in the RSDT/XSDT with a unique OEM Table ID is loaded in the order presented in the RSDT/XSDT.

- Additional tables can only add data; they cannot overwrite data from previous tables.

This allows the OEM to provide the base support in one table and add smaller system options in other tables. For example, the OEM might put dynamic object definitions into a secondary table such that the firmware can construct the dynamic information at boot without needing to edit the static DSDT. A SSDT can only rely on the DSDT being loaded prior to it.

Table 5.18: Secondary System Description Table Fields (SSDT)

Field	Byte Length	Byte Offset	Description
Header			
Signature	4	0	‘SSDT’ Signature for the Secondary System Description Table.
Length	4	4	Length, in bytes, of the entire SSDT (including the header).
Revision	1	8	2
Checksum	1	9	Entire table must sum to zero.
OEMID	6	10	OEM ID
OEM Table ID	8	16	The manufacture model ID.
OEM Revision	4	24	OEM revision of DSDT for supplied OEM Table ID.
Creator ID	4	28	Vendor ID for the ASL Compiler.
Creator Revision	4	32	Revision number of the ASL Compiler.
Definition Block	n	36	n bytes of AML code (see Section 5.4).

5.2.11.3 Persistent System Description Table (PSDT)

The table signature, “PSDT” refers to the Persistent System Description Table (PSDT) defined in the ACPI 1.0 specification. The PSDT was judged to provide no specific benefit and as such has been deleted from follow-on versions of the ACPI specification. OSPM will evaluate a table with the “PSDT” signature in like manner to the evaluation of an SSDT as described in [Section 5.2.11.2](#)

5.2.12 Multiple APIC Description Table (MADT)

The ACPI interrupt model describes all interrupts for the entire system in a uniform interrupt model implementation. Supported interrupt models include:

- the PC-AT-compatible dual 8259 interrupt controller,
- for Intel processor-based systems: the Intel Advanced Programmable Interrupt Controller (APIC) and Intel Streamlined Advanced Programmable Interrupt,
- for ARM processor-based systems: the Generic Interrupt Controller (GIC),
- for LoongArch processor-based systems: the LoongArch Programmable Interrupt Controller (LPIC).

The choice of interrupt model(s) to support is up to the platform designer. The interrupt model cannot be dynamically changed by system firmware; OSPM will choose which model to use and install support for that model at the time of installation. If a platform supports multiple models, an OS will install support for only one of the models and will not mix models. Multi-boot capability is a feature in many modern operating systems. This means that a system may have multiple operating systems or multiple instances of an OS installed at any one time. Platform designers must allow for this.

This section describes the format of the Multiple APIC Description Table (MADT), which provides OSPM with information necessary for operation on systems with APIC, SAPIC, GIC, or LPIC implementations.

ACPI represents all interrupts as “flat” values known as global system interrupts. Therefore to support APICs, SAPICs, GICs, or LPICs on an ACPI-enabled system, each used interrupt input must be mapped to the global system interrupt value used by ACPI. See [Global System Interrupts](#) for more details.

Additional support is required to handle various multi-processor functions that implementations might support (for example, identifying each processor’s local interrupt controller ID).

All addresses in the MADT are processor-relative physical addresses.

Starting with ACPI Specification 6.3, the use of the Processor() object was deprecated. Only legacy systems should continue with this usage. On the Itanium architecture only, a _UID is provided for the Processor() that is a string object. This usage of _UID is also deprecated since it can preclude an OSPM from being able to match a processor to a non-enumerable device, such as those defined in the MADT. From ACPI Specification 6.3 onward, all processor objects for all architectures except Itanium must now use Device() objects with an _HID of ACPI0007, and use only integer _UID values.

Table 5.19: Multiple APIC Description Table (MADT) Format

Field	Byte Length	Byte Offset	Description
Header			
Signature	4	0	'APIC' Signature for the Multiple APIC Description Table.
Length	4	4	Length, in bytes, of the entire MADT.
Revision	1	8	6
Checksum	1	9	Entire table must sum to zero.
OEMID	6	10	OEM ID
OEM Table ID	8	16	For the MADT, the table ID is the manufacturer model ID.
OEM Revision	4	24	OEM revision of MADT for supplied OEM Table ID.
Creator ID	4	28	Vendor ID of utility that created the table. For tables containing Definition Blocks, this is the ID for the ASL Compiler.
Creator Revision	4	32	Revision of utility that created the table. For tables containing Definition Blocks, this is the revision for the ASL Compiler.
Local Interrupt Controller Address	4	36	The 32-bit physical address at which each processor can access its local interrupt controller.
Flags	4	40	Multiple APIC flags. See Multiple APIC Flags for a description of this field.
Interrupt Controller Structure[n]	–	44	A list of interrupt controller structures for this implementation. This list will contain all of the structures from Interrupt Controller Structure Types needed to support this platform. These structures are described in the following sections.

Table 5.20: Multiple APIC Flags

Multiple APIC Flags	Bit Length	Bit Offset	Description
PCAT_COMPAT	1	0	A one indicates that the system also has a PC-AT-compatible dual-8259 setup. The 8259 vectors must be disabled (that is, masked) when enabling the ACPI APIC operation.
<i>Reserved</i>	31	1	This value is zero.

Immediately after the Flags value in the MADT is a list of interrupt controller structures that declare the interrupt features of the machine. The first byte of each structure declares the type of that structure and the second byte declares the length of that structure.

Table 5.21: Interrupt Controller Structure Types

Value	Description	_MAT for Processor object (a)	_MAT for an I/O APIC object (b)	Reference
0	Processor Local APIC	yes	no	Section 5.2.12.2
1	I/O APIC	no	yes	Section 5.2.12.3
2	Interrupt Source Override	no	yes	Section 5.2.12.5

continues on next page

Table 5.21 – continued from previous page

3	Non-maskable Interrupt Source (NMI)	no	yes	Section 5.2.12.6
4	Local APIC NMI	yes	no	Section 5.2.12.7
5	Local APIC Address Override	no	no	Section 5.2.12.8
6	I/O SAPIC	no	yes	Section 5.2.12.9
7	Local SAPIC	yes	no	Section 5.2.12.10
8	Platform Interrupt Sources	no	yes	Section 5.2.12.11
9	Processor Local x2APIC	yes	no	Section 5.2.12.12
0xA	Local x2APIC NMI	yes	no	Section 5.2.12.13
0xB	GIC CPU Interface (GICC)	yes	no	Section 5.2.12.14
0xC	GIC Distributor (GICD)	no	no	Section 5.2.12.15
0xD	GIC MSI Frame	no	no	Section 5.2.12.16
0xE	GIC Redistributor (GICR)	no	no	Section 5.2.12.17
0xF	GIC Interrupt Translation Service (ITS)	no	no	Section 5.2.12.18
0x10	Multiprocessor Wakeup	no	no	Section 5.2.12.19
0x11	Core Programmable Interrupt Controller (CORE PIC)	no	no	Section 5.2.12.20
0x12	Legacy I/O Programmable Interrupt Controller (LIO PIC)	no	no	Section 5.2.12.21
0x13	HyperTransport Programmable Interrupt Controller (HT PIC)	no	no	Section 5.2.12.22
0x14	Extend I/O Programmable Interrupt Controller (EIO PIC)	no	no	Section 5.2.12.23
0x15	MSI Programmable Interrupt Controller (MSI PIC)	no	no	Section 5.2.12.24
0x16	Bridge I/O Programmable Interrupt Controller (BIO PIC)	no	no	Section 5.2.12.25
0x17	Low Pin Count Programmable Interrupt Controller (LPC PIC)	no	no	Section 5.2.12.26
0x18-0x7F	Reserved. OSPM skips structures of the reserved type.	no	no	
0x80-0xFF	Reserved for OEM use	no	no	

Notes

(a) When `_MAT` (see Section 6.2.10) appears under a Processor Device object (see Section 8.4), OSPM processes the Interrupt Controller Structures returned by `_MAT` with the types labeled “yes” and ignores other types.

(b) When `_MAT` appears under an I/O APIC Device, OSPM processes the Interrupt Controller Structures returned by `_MAT` with the types labeled “yes” and ignores other types.

5.2.12.1 MADT Processor Local APIC / SAPIC Structure Entry Order

OSPM implementations may limit the number of supported processors on multi-processor platforms. OSPM executes on the boot processor to initialize the platform including other processors. To ensure that the boot processor is supported post initialization, two guidelines should be followed. The first is that OSPM should initialize processors in the order that they appear in the MADT. The second is that platform firmware should list the boot processor as the first processor entry in the MADT.

The advent of multi-threaded processors yielded multiple logical processors executing on common processor hardware. ACPI defines logical processors in an identical manner as physical processors. To ensure that non multi-threading aware OSPM implementations realize optimal performance on platforms containing multi-threaded processors, two guidelines should be followed. The first is the same as above, that is, OSPM should initialize processors in the order that they appear in the MADT. The second is that platform firmware should list the first logical processor of each of the individual multi-threaded processors in the MADT before listing any of the second logical processors. This approach should be used for all successive logical processors.

Failure of OSPM implementations and platform firmware to abide by these guidelines can result in both unpredictable and non optimal platform operation.

5.2.12.2 Processor Local APIC Structure

When using the APIC interrupt model, each processor in the system is required to have a Processor Local APIC record in the MADT, and a processor device object in the DSDT. OSPM does not expect the information provided in this table to be updated if the processor information changes during the lifespan of an OS boot. While in the sleeping state, processors are not allowed to be added, removed, nor can their APIC ID or Flags change. When a processor is not present, the Processor Local APIC information is either not reported or flagged as disabled.

Table 5.22: Processor Local APIC Structure

Field	Byte Length	Byte Offset	Description
Type	1	0	0 Processor Local APIC structure
Length	1	1	8
ACPI Processor UID	1	2	The OS associates this Local APIC Structure with a processor object in the namespace when the <code>_UID</code> child object of the processor's device object (or the <code>ProcessorId</code> listed in the Processor declaration operator) evaluates to a numeric value that matches the numeric value in this field. Note that the use of the Processor declaration operator is deprecated. See the description at the beginning of this section for more information.
APIC ID	1	3	The processor's local APIC ID.
Flags	4	4	Local APIC flags. See the following table (Table 5.23) for a description of this field.

Table 5.23: Local APIC Flags

Local APIC Flags	Bit Length	Bit Off-set	Description
Enabled	1	0	If this bit is set the processor is ready for use. If this bit is clear and the Online Capable bit is set, system hardware supports enabling this processor during OS runtime. If this bit is clear and the Online Capable bit is also clear, this processor is unusable, and OSPM shall ignore the contents of the Processor Local APIC Structure.
Online Capable	1	1	The information conveyed by this bit depends on the value of the Enabled bit. If the Enabled bit is set, this bit is reserved and must be zero. Otherwise, if this this bit is set, system hardware supports enabling this processor during OS runtime.
<i>Reserved</i>	30	2	Must be zero.

5.2.12.3 I/O APIC Structure

In an APIC implementation, there are one or more I/O APICs. Each I/O APIC has a series of interrupt inputs, referred to as INTIn, where the value of n is from 0 to the number of the last interrupt input on the I/O APIC. The I/O APIC structure declares which global system interrupts are uniquely associated with the I/O APIC interrupt inputs. There is one I/O APIC structure for each I/O APIC in the system. For more information on global system interrupts see *Global System Interrupts*.

Table 5.24: I/O APIC Structure

Field	Byte Length	Byte Offset	Description
Type	1	0	1 I/O APIC structure
Length	1	1	12
I/O APIC ID	1	2	The I/O APIC's ID.
<i>Reserved</i>	1	3	0
I/O APIC Address	4	4	The 32-bit physical address to access this I/O APIC. Each I/O APIC resides at a unique address.
Global System Interrupt Base	4	8	The global system interrupt number where this I/O APIC's interrupt inputs start. The number of interrupt inputs is determined by the I/O APIC's Max Redir Entry register.

5.2.12.4 Platforms with APIC and Dual 8259 Support

Systems that support both APIC and dual 8259 interrupt models must map global system interrupts 0-15 to the 8259 IRQs 0-15, except where Interrupt Source Overrides are provided (see [Section 5.2.12.5](#) below). This means that I/O APIC interrupt inputs 0-15 must be mapped to global system interrupts 0-15 and have identical sources as the 8259 IRQs 0-15 unless overrides are used. This allows a platform to support OSPM implementations that use the APIC model as well as OSPM implementations that use the 8259 model (OSPM will only use one model; it will not mix models).

When OSPM supports the 8259 model, it will assume that all interrupt descriptors reporting global system interrupts 0-15 correspond to 8259 IRQs. In the 8259 model all global system interrupts greater than 15 are ignored. If OSPM implements APIC support, it will enable the APIC as described by the APIC specification and will use all reported global system interrupts that fall within the limits of the interrupt inputs defined by the I/O APIC structures. For more information on hardware resource configuration see [Section 6](#)

5.2.12.5 Interrupt Source Override Structure

Interrupt Source Overrides are necessary to describe variances between the IA-PC standard dual 8259 interrupt definition and the platform’s implementation.

It is assumed that the ISA interrupts will be identity-mapped into the first I/O APIC sources. Most existing APIC designs, however, will contain at least one exception to this assumption. The Interrupt Source Override Structure is provided in order to describe these exceptions. It is not necessary to provide an Interrupt Source Override for every ISA interrupt. Only those that are not identity-mapped onto the APIC interrupt inputs need be described.

- This specification only supports overriding ISA interrupt sources.

For example, if your machine has the ISA Programmable Interrupt Timer (PIT) connected to ISA IRQ 0, but in APIC mode, it is connected to I/O APIC interrupt input 2, then you would need an Interrupt Source Override where the source entry is ‘0’ and the Global System Interrupt is ‘2.’

Table 5.25: Interrupt Source Override Structure

Field	Byte Length	Byte Offset	Description
Type	1	0	2 Interrupt Source Override
Length	1	1	10
Bus	1	2	0 Constant, meaning ISA
Source	1	3	Bus-relative interrupt source (IRQ)
Global System Interrupt	4	4	The Global System Interrupt that this bus-relative interrupt source will signal.
Flags	2	8	MPS INTI flags. See the corresponding tabel below for a description of this field.

The MPS INTI flags listed in Table 5.26 are identical to the flags used in the MPS version 1.4 specification, Table 4-10. The Polarity flags are the PO bits and the Trigger Mode flags are the EL bits.

Table 5.26: MPS INTI Flags

Local APIC - Flags	Bit Length	Bit Off-set	Description
Polarity	2	0	Polarity of the APIC I/O input signals: 00 Conforms to the specifications of the bus (for example, EISA is active-low for level-triggered interrupts). 01 Active high 10 <i>Reserved</i> 11 Active low
Trigger Mode	2	2	Trigger mode of the APIC I/O Input signals: 00 Conforms to specifications of the bus (For example, ISA is edge-triggered) 01 Edge-triggered 10 <i>Reserved</i> 11 Level-triggered
<i>Reserved</i>	12	4	Must be zero.

Interrupt Source Overrides are also necessary when an identity mapped interrupt input has a non-standard polarity.

- You must have an interrupt source override entry for the IRQ mapped to the SCI interrupt if this IRQ is not identity mapped. This entry will override the value in SCL_INT in FADT. For example, if SCI is connected to IRQ 9 in PIC mode and IRQ 9 is connected to INTIN11 in APIC mode, you should have 9 in SCL_INT in the FADT and an interrupt source override entry mapping IRQ 9 to INTIN11.

5.2.12.6 Non-Maskable Interrupt (NMI) Source Structure

This structure allows a platform designer to specify which I/O (S)APIC interrupt inputs should be enabled as non-maskable. Any source that is non-maskable will not be available for use by devices.

Table 5.27: NMI Source Structure

Field	Byte Length	Byte Offset	Description
Type	1	0	3 NMI Source
Length	1	1	8
Flags	2	2	Same as MPS INTI flags
Global System Interrupt	4	4	The Global System Interrupt that this NMI will signal.

5.2.12.7 Local APIC NMI Structure

This structure describes the Local APIC interrupt input (LINTn) that NMI is connected to for each of the processors in the system where such a connection exists. This information is needed by OSPM to enable the appropriate local APIC entry.

Each Local APIC NMI connection requires a separate Local APIC NMI structure. For example, if the platform has 4 processors with ID 0-3 and NMI is connected LINT1 for processor 3 and 2, two Local APIC NMI entries would be needed in the MADT.

Table 5.28: Local APIC NMI Structure

Field	Byte Length	Byte Offset	Description
Type	1	0	4 Local APIC NMI Structure
Length	1	1	6
ACPI Processor UID	1	2	Value corresponding to the _UID listed in the processor's device object, or the Processor ID corresponding to the ID listed in the processor object. A value of 0xFF signifies that this applies to all processors in the machine. Note that the use of the Processor declaration operator is deprecated. See the compatibility note in Processor Local x2APIC Structure, and see Processor (Declare Processor).
Flags	2	3	MPS INTI flags. See Table 5.26 for a description of this field.
Local APIC LINT#	1	5	Local APIC interrupt input LINTn to which NMI is connected.

5.2.12.8 Local APIC Address Override Structure

This optional structure supports 64-bit systems by providing an override of the physical address of the local APIC in the MADT's table header, which is defined as a 32-bit field.

If defined, OSPM must use the address specified in this structure for all local APICs (and local SAPICs), rather than the address contained in the MADT's table header. Only one Local APIC Address Override Structure may be defined.

Table 5.29: Local APIC Address Override Structure

Field	Byte Length	Byte Offset	Description
Type	1	0	5 Local APIC Address Override Structure
Length	1	1	12
<i>Reserved</i>	2	2	Reserved (must be set to zero)
Local APIC Address	8	4	Physical address of Local APIC. For Itanium™ Processor Family (IPF)-based platforms, this field contains the starting address of the Processor Interrupt Block. See the Intel® Itanium™ Architecture Software Developer's Manual for more information.

5.2.12.9 I/O SAPIC Structure

The I/O SAPIC structure is very similar to the I/O APIC structure. If both I/O APIC and I/O SAPIC structures exist for a specific APIC ID, the information in the I/O SAPIC structure must be used.

The I/O SAPIC structure uses the I/O APIC ID field as defined in the I/O APIC table. The Global System Interrupt Base field remains unchanged but has been moved. The I/O APIC Address field has been deleted. A new address and reserved field have been added.

Table 5.30: I/O SAPIC Structure

Field	Byte Length	Byte Offset	Description
Type	1	0	6 I/O SAPIC Structure
Length	1	1	16
I/O APIC ID	1	2	I/O SAPIC ID
<i>Reserved</i>	1	3	Reserved (must be zero)
Global System Interrupt Base	4	4	The global system interrupt number where this I/O SAPIC's interrupt inputs start. The number of interrupt inputs is determined by the I/O SAPIC's Max Redir Entry register.
I/O SAPIC Address	8	8	The 64-bit physical address to access this I/O SAPIC. Each I/O SAPIC resides at a unique address.

If defined, OSPM must use the information contained in the I/O SAPIC structure instead of the information from the I/O APIC structure.

If both I/O APIC and an I/O SAPIC structures exist in an MADT, the OEM/platform firmware writer must prevent "mixing" I/O APIC and I/O SAPIC addresses. This is done by ensuring that there are at least as many I/O SAPIC structures as I/O APIC structures and that every I/O APIC structure has a corresponding I/O SAPIC structure (same APIC ID).

5.2.12.10 Local SAPIC Structure

The Processor local SAPIC structure is very similar to the processor local APIC structure. When using the SAPIC interrupt model, each processor in the system is required to have a Processor Local SAPIC record in the MADT, and a processor device object in the DSDT. OSPM does not expect the information provided in this table to be updated if the processor information changes during the lifespan of an OS boot. While in the sleeping state, processors are not allowed to be added, removed, nor can their SAPIC ID or Flags change. When a processor is not present, the Processor Local SAPIC information is either not reported or flagged as disabled.

Table 5.31: Processor Local SAPIC Structure

Field	Byte Length	Byte Offset	Description
Type	1	0	7 Processor Local SAPIC structure
Length	1	1	Length of the Local SAPIC Structure in bytes.
ACPI Processor ID	1	2	OSPM associates the Local SAPIC Structure with a processor object declared in the namespace using the Processor statement by matching the processor object's ProcessorID value with this field. The use of the Processor statement is deprecated. See the compatibility note in Processor Local x2APIC Structure, and Processor (Declare Processor).
Local SAPIC ID	1	3	The processor's local SAPIC ID
Local SAPIC EID	1	4	The processor's local SAPIC EID
<i>Reserved</i>	3	5	Reserved (must be set to zero)
Flags	4	8	Local SAPIC flags. See Local APIC Flags for a description of this field.
ACPI Processor UID Value	4	12	OSPM associates the Local SAPIC Structure with a processor object declared in the namespace using the Device statement, when the _UID child object of the processor device evaluates to a numeric value, by matching the numeric value with this field.
ACPI Processor UID String	>=1	16	OSPM associates the Local SAPIC Structure with a processor object declared in the namespace using the Device statement, when the _UID child object of the processor device evaluates to a string, by matching the string with this field. This value is stored as a null-terminated ASCII string.

5.2.12.11 Platform Interrupt Source Structure

The Platform Interrupt Source structure is used to communicate which I/O SAPIC interrupt inputs are connected to the platform interrupt sources.

Platform Management Interrupts (PMIs) are used to invoke platform firmware to handle various events (similar to SMI in IA-32). The Intel® Itanium™ architecture permits the I/O SAPIC to send a vector value in the interrupt message of the PMI type. This value is specified in the I/O SAPIC Vector field of the Platform Interrupt Sources Structure.

INIT messages cause processors to soft reset.

If a platform can generate an interrupt after correcting platform errors (e.g., single bit error correction), the interrupt input line used to signal such corrected errors is specified by the Global System Interrupt field in the following table. Some systems may restrict the retrieval of corrected platform error information to a specific processor. In such cases, the firmware indicates the processor that can retrieve the corrected platform error information through the Processor ID and EID fields in the structure below. OSPM is required to program the I/O SAPIC redirection table entries with the Processor ID, EID values specified by the ACPI system firmware. On platforms where the retrieval of corrected

platform error information can be performed on any processor, the firmware indicates this capability by setting the CPEI Processor Override flag in the Platform Interrupt Source Flags field of the structure below. If the CPEI Processor Override Flag is set, OSPM uses the processor specified by Processor ID, and EID fields of the structure below only as a target processor hint and the error retrieval can be performed on any processor in the system. However, firmware is required to specify valid values in Processor ID, EID fields to ensure backward compatibility.

If the CPEI Processor Override flag is clear, OSPM may reject a ejection request for the processor that is targeted for the corrected platform error interrupt. If the CPEI Processor Override flag is set, OSPM can retarget the corrected platform error interrupt to a different processor when the target processor is ejected.

Note that the `_MAT` object can return a buffer containing Platform Interrupt Source Structure entries. It is allowed for such an entry to refer to a Global System Interrupt that is already specified by a Platform Interrupt Source Structure provided through the static MADT table, provided the value of platform interrupt source flags are identical.

Refer to the Itanium™ Processor Family System Abstraction Layer (SAL) Specification for details on handling the Corrected Platform Error Interrupt.

Table 5.32: Platform Interrupt Source Structure

Field	Byte Length	Byte Offset	Description
Type	1	0	8 Platform Interrupt Source structure
Length	1	1	16
Flags	2	2	MPS INTI flags. See Table 5.26 for a description of this field.
Interrupt Type	1	4	1 PMI 2 INIT 3 Corrected Platform Error Interrupt. All other values are reserved.
Processor ID	1	5	Processor ID of destination.
Processor EID	1	6	Processor EID of destination.
I/O SAPIC Vector	1	7	Value that OSPM must use to program the vector field of the I/O SAPIC redirection table entry for entries with the PMI interrupt type.
Global System Interrupt	4	8	The Global System Interrupt that this platform interrupt will signal.
Platform Interrupt Source Flags	4	12	Platform Interrupt Source Flags. See Platform Interrupt Source Flags for a description of this field

Table 5.33: Platform Interrupt Source Flags

Platform Interrupt Source Flags	Bit Length	Bit Offset	Description
CPEI Processor Override	1	0	When set, indicates that retrieval of error information is allowed from any processor and OSPM is to use the information provided by the processor ID, EID fields of the Platform Interrupt Source Structure as a target processor hint.
<i>Reserved</i>	31	1	Must be zero.

5.2.12.12 Processor Local x2APIC Structure

The Processor X2APIC structure is very similar to the processor local APIC structure. When using the X2APIC interrupt model, logical processors are required to have a processor device object in the DSDT and must convey the processor's APIC information to OSPM using the Processor Local X2APIC structure.

- [Compatibility note] On some legacy OSes, Logical processors with APIC ID values less than 255 (whether in XAPIC or X2APIC mode) must use the Processor Local APIC structure to convey their APIC information to OSPM, and those processors must be declared in the DSDT using the Processor() keyword. Logical processors with APIC ID values 255 and greater must use the Processor Local x2APIC structure and be declared using the Device() keyword.

OSPM does not expect the information provided in this table to be updated if the processor information changes during the lifespan of an OS boot. While in the sleeping state, logical processors must not be added or removed, nor can their X2APIC ID or x2APIC Flags change. When a logical processor is not present, the processor local X2APIC information is either not reported or flagged as disabled.

The format of x2APIC structure is listed in [Section 5.2.12.12](#).

Table 5.34: Processor Local x2APIC Structure

Field	Byte Length	Byte Offset	Description
Type	1	0	9 Processor Local x2APIC structure
Length	1	1	16
<i>Reserved</i>	2	2	Reserved - Must be zero
X2APIC ID	4	4	The processor's local x2APIC ID.
Flags	4	8	Same as Local APIC flags. See Local APIC Flags for a description of this field.
ACPI Processor UID	4	12	OSPM associates the X2APIC Structure with a processor object declared in the namespace using the Device statement, when the _UID child object of the processor device evaluates to a numeric value, by matching the numeric value with this field.

5.2.12.13 Local x2APIC NMI Structure

The Local APIC NMI and Local x2APIC NMI structures describe the interrupt input (LINT_n) that NMI is connected to for each of the logical processors in the system where such a connection exists. Each NMI connection to a processor requires a separate NMI structure. This information is needed by OSPM to enable the appropriate APIC entry.

NMI connection to a logical processor with local x2APIC ID 255 and greater requires an X2APIC NMI structure. NMI connection to a logical processor with an x2APIC ID less than 255 requires a Local APIC NMI structure. For example, if the platform contains 8 logical processors with x2APIC IDs 0-3 and 256-259 and NMI is connected LINT₁ for processor 3, 2, 256 and 257 then two Local APIC NMI entries and two X2APIC NMI entries must be provided in the MADT.

The Local APIC NMI structure is used to specify global LINT_x for all processors if all logical processors have x2APIC ID less than 255. If the platform contains any logical processors with an x2APIC ID of 255 or greater then the Local X2APIC NMI structure must be used to specify global LINT_x for ALL logical processors. The format of x2APIC NMI structure is listed in [Section 5.2.12.13](#).

Table 5.35: Local x2APIC NMI Structure

Field	Byte Length	Byte Offset	Description
Type	1	0	0AH Local x2APIC NMI Structure
Length	1	1	12
Flags	2	2	Same as MPS INTI flags. See MPS INTI Flags For a description of this field.
ACPI Processor UID	4	4	UID corresponding to the ID listed in the processor Device object. A value of 0xFFFFFFFF signifies that this applies to all processors in the machine.
Local x2APIC LINT#	1	8	Local x2APIC interrupt input LINTn to which NMI is connected.
<i>Reserved</i>	3	9	Reserved - Must be zero.

5.2.12.14 GIC CPU Interface (GICC) Structure

In the GIC interrupt model, logical processors are required to have a Processor Device object in the DSDT, and must convey each processor’s GIC information to the OS using the GICC structure.

The format of the GICC structure is shown in the following table.

Table 5.36: GICC Structure

Field	Byte Length	Byte Offset	Description
Type	1	0	0xB GICC structure
Length	1	1	82
<i>Reserved</i>	2	2	Reserved - Must be zero
CPU Interface Number	4	4	GIC’s CPU Interface Number. In GICv1/v2 implementations, this value matches the bit index of the associated processor in the GIC distributor’s GICD_ITARGETSR register. For GICv3/4 implementations this field must be provided by the platform, if compatibility mode is supported. If it is not supported by the implementation, then this field must be zero.
ACPI Processor UID	4	8	The OS associates this GICC Structure with a processor device object in the namespace when the _UID child object of the processor device evaluates to a numeric value that matches the numeric value in this field.
Flags	4	12	See GICC CPU Interface Flags.
Parking Protocol Version	4	16	Version of the ARM-Processor Parking Protocol implemented. See http://uefi.org/acpi . The document link is listed under “Multiprocessor Startup for ARM Platforms” For systems that support PSCI exclusively and do not support the parking protocol, this field must be set to 0.
Performance Interrupt GSIV	4	20	The GSIV used for Performance Monitoring Interrupts
Parked Address	8	24	The 64-bit physical address of the processor’s Parking Protocol mailbox

continues on next page

Table 5.36 – continued from previous page

Physical Base Address	8	32	On GICv1/v2 systems and GICv3/4 systems in GICv2 compatibility mode, this field holds the 64-bit physical address at which the processor can access this GIC CPU Interface. If provided here, the “Local Interrupt Controller Address” field in the MADT must be ignored by the OSPM.
GICV	8	40	Address of the GIC virtual CPU interface registers. If the platform is not presenting a GICv2 with virtualization extensions this field can be 0.
GICH	8	48	Address of the GIC virtual interface control block registers. If the platform is not presenting a GICv2 with virtualization extensions this field can be 0.
VGIC Maintenance interrupt	4	56	GSIV for Virtual GIC maintenance interrupt
GICR Base Address	8	60	On systems supporting GICv3 and above, this field holds the 64-bit physical address of the associated Redistributor. If all of the GIC Redistributors are in the always-on power domain, GICR structures should be used to describe the Redistributors instead, and this field must be set to 0. If a GICR structure is present in the MADT then this field must be ignored by the OSPM.
MPIDR	8	68	This fields follows the MPIDR formatting of ARM architecture. If ARMv7 architecture is used then the format must be as follows: Bits [63:24] Must be zero Bits [23:16] Aff2 : Match Aff2 of target processor MPIDR Bits [15:8] Aff1 : Match Aff1 of target processor MPIDR Bits [7:0] Aff0 : Match Aff0 of target processor MPIDR For platforms implementing ARMv8 the format must be: Bits [63:40] Must be zero Bits [39:32] Aff3 : Match Aff3 of target processor MPIDR Bits [31:24] Must be zero Bits [23:16] Aff2 : Match Aff2 of target processor MPIDR Bits [15:8] Aff1 : Match Aff1 of target processor MPIDR Bits [7:0] Aff0 : Match Aff0 of target processor MPIDR
Processor Power Efficiency Class	1	76	Describes the relative power efficiency of the associated processor. Lower efficiency class numbers are more efficient than higher ones (e.g. efficiency class 0 should be treated as more efficient than efficiency class 1). However, absolute values of this number have no meaning: 2 isn’t necessarily half as efficient as 1.
<i>Reserved</i>	1	77	Must be zero.
SPE overflow Interrupt	2	78	Statistical Profiling Extension buffer overflow GSIV. This interrupt is a level triggered PPI. Zero if SPE is not supported by this processor.
TRBE Interrupt	2	80	Trace Buffer Extension interrupt GSIV. This interrupt is a level triggered PPI. Zero if TRBE feature is not supported by this processor. NOTE: This field was introduced in ACPI Specification version 6.5.

Table 5.37: GICC CPU Interface Flags

GIC Flags	Bit Length	Bit Off-set	Description
Enabled	1	0	If this bit is set, the processor is ready for use. If this bit is clear and the Online Capable bit is set, the system supports enabling this processor during OS runtime. If this bit is clear and the Online Capable bit is also clear, this processor is unusable, and the operating system support will not attempt to use it.
Performance Interrupt Mode	1	1	0 - Level-triggered 1 - Edge-Triggered
VGIC Maintenance Interrupt Mode Flags	1	2	0 - Level-triggered 1 - Edge-Triggered
Online Capable	1	3	The information conveyed by this bit depends on the value of the Enabled bit. If the Enabled bit is set, this bit is reserved and must be zero. Otherwise, if this bit is set, the system supports enabling this processor later during OS runtime.
<i>Reserved</i>	28	4	Must be zero.

Note: All processors are assumed to be always physically present

5.2.12.15 GIC Distributor (GICD) Structure

ACPI represents all wired interrupts as “flat” values known as global system interrupts (GSIVs) as described in Section 5.2.13 . On ARM-based systems the Generic Interrupt Controller (GIC) manages interrupts on the system. Each interrupt is identified in the GIC by an interrupt identifier (INTID). ACPI GSIVs map one to one to GIC INTIDs for peripheral interrupts, whether shared (SPI) or private (PPI). The GIC distributor structure describes the GIC distributor to the OS. One, and only one, GIC distributor structure must be present in the MADT for an ARM based system.

The format of the GICD structure is listed in Table 5.38 .

Table 5.38: GICD Structure

Field	Byte Length	Byte Offset	Description
Type	1	0	0xC GICD structure
Length	1	1	24
<i>Reserved</i>	2	2	Reserved - Must be zero
GIC ID	4	4	This GIC Distributor’s hardware ID
Physical Base Address	8	8	The 64-bit physical address for this Distributor
System Vector Base	4	16	Reserved - Must be zero

continues on next page

Table 5.38 – continued from previous page

Field	Byte Length	Byte Offset	Description
GIC version	1	20	0x00: No GIC version is specified, fall back to hardware discovery for GIC version 0x01: GICv1 0x02: GICv2 0x03: GICv3 0x04: GICv4 0x05-0xFF, Reserved for future use.
<i>Reserved</i>	3	21	Must be zero

5.2.12.16 GIC MSI Frame Structure

Each GICv2m MSI frame consists of a 4k page which includes registers to generate message signaled interrupts to an associated GIC distributor. The frame also includes registers to discover the set of distributor lines which may be signaled by MSIs from that frame. A system may have multiple MSI frames, and separate frames may be defined for secure and non-secure access. This structure must only be used to describe non-secure MSI frames.

The format of the GIC MSI Frame Structure is listed in [Section 5.2.12.16](#).

Table 5.39: GIC MSI Frame Structure

Field	Byte Length	Byte Offset	Description
Type	1	0	0xD GIC MSI Frame structure
Length	1	1	24
<i>Reserved</i>	2	2	Reserved - Must be zero
GIC MSI Frame ID	4	4	GIC MSI Frame ID. In a system with multiple GIC MSI frames, this value must be unique to each one.
Physical Base Address	8	8	The 64-bit physical address for this MSI Frame
Flags	4	16	GIC MSI Frame Flags. See Section 5.2.12.16
SPI Count	2	20	SPI Count used by this frame. Unless the SPI Count Select flag is set to 1 this value should match the lower 16 bits of the MSI_TYPER register in the frame.
SPI Base	2	22	SPI Base used by this frame. Unless the SPI Base Select flag is set to 1 this value should match the upper 16 bits of the MSI_TYPER register in the frame.

Table 5.40: GIC MSI Frame Flags

GIC MSI Frame Flags	Bit Length	Bit Offset	Description
SPI Count/Base Select	1	0	0: The SPI Count and Base fields should be ignored, and the actual values should be queried from the MSI_TYPER register in the associated GIC MSI frame. 1: The SPI Count and Base values override the values specified in the MSI_TYPER register in the associated GIC MSI frame.
<i>Reserved</i>	31	1	Must be zero.

5.2.12.17 GIC Redistributor (GICR) Structure

The GICR Structure is described in Table 5.41. This structure enables the discovery of GIC Redistributor base addresses by providing the Physical Base Address of a page range containing the GIC Redistributors. More than one GICR Structure may be presented in the MADT. GICR structures should only be used when describing GIC implementations which conform to version 3 or higher of the GIC architecture and which place all Redistributors in the always-on power domain. When a GICR structure is presented, the OSPM must ignore the GICR Base Address field of the GICC structures (see the following table).

Table 5.41: GICR Structure

Field	Byte Length	Byte Offset	Description
Type	1	0	0xE GICR structure
Length	1	1	16
Reserved	2	2	Reserved - Must be zero
Discovery Range Base Address	8	4	The 64-bit physical address of a page range containing all GIC Redistributors
Discovery Range Length	4	12	Length of the GIC Redistributor Discovery page range.

5.2.12.18 GIC Interrupt Translation Service (ITS) Structure

The GIC ITS is optionally supported in GICv3/v4 implementations. The format of the GIC ITS Structure is listed in Table 5.42 :

Table 5.42: GIC ITS Structure

Field	Byte Length	Byte Offset	Description
Type	1	0	0xF GIC ITS structure
Length	1	1	20
Reserved	2	2	Reserved - Must be zero
GIC ITS ID	4	4	GIC ITS ID. In a system with multiple GIC ITS units, this value must be unique to each one.
Physical Base Address	8	8	The 64-bit physical address for the Interrupt Translation Service
Reserved	4	16	Reserved - Must be zero

5.2.12.19 Multiprocessor Wakeup Structure

The platform firmware publishes a multiprocessor wakeup structure to let the bootstrap processor wake up application processors with a mailbox. The mailbox is memory that the firmware reserves so that each processor can have the OS send a message to them.

During system boot, the firmware puts the application processors in a state to check the mailbox. The shared mailbox is a 4K-aligned 4K-size memory block allocated by the firmware in the ACPINvs memory. The firmware is not allowed to modify the mailbox location when the firmware transfer the control to an OS loader. The mailbox is broken down into two 2KB sections: an OS section and a firmware section.

The OS section can only be written by OS and read by the firmware, except the command field. The application processor need clear the command to Noop(0) as the acknowledgement that the command is received. The firmware must cache the content in the mailbox which might be used later before clear the command such as WakeupVector. Only after the command is changed to Noop(0), the OS can send the next command. The firmware section must be

considered read-only to the OS and is only to be written to by the firmware. All data communication between the OS and FW must be in little endian format.

The OS section contains command, flags, APIC ID, and a wakeup address. After the OS detects the processor number from the MADT table, the OS may prepare the wakeup routine, fill the wakeup address field in the mailbox, indicate which processor need to be wakeup in the APID ID field, and send wakeup command. Once an application processor detects the wakeup command and its own APIC ID, the application processor will jump to the OS-provided wakeup address. The application processor will ignore the command if the APIC ID does not match its own.

For each application processor, the mailbox can be used only once for the wakeup command. After the application process takes the action according to the command, this mailbox will no longer be checked by this application processor. Other processors can continue using the mailbox for the next command.

Table 5.43: Multiprocessor Wakeup Structure

Field	Byte Length	Byte Offset	Description
Type	1	0	0x10 Multiprocessor Wakeup structure
Length	1	1	16
MailBoxVersion	2	2	Version of the mailbox. 0 for this version of the spec.
<i>Reserved</i>	4	4	Must be 0.
MailBoxAddress	8	8	Physical address of the mailbox. It must be in ACPIv5. It must also be 4K bytes aligned. See Table 5.44 for the Mailbox definition.

Table 5.44: Multiprocessor Wakeup Mailbox Structure

Field	Byte Length	Byte Offset	Description
Command	2	0	0: Noop - no operation. 1: Wakeup – jump to the wakeup vector. 2-0xFFFF: Reserved
<i>Reserved</i>	2	2	Must be 0.
ApicId	4	4	The processor’s local APIC ID. The application processor shall check if the ApicId field matches its own APIC ID. The application processor shall ignore the command in case of APIC ID mismatch.
WakeupVector	8	8	The wakeup address for application processor(s). For Intel processors, the execution environment is: Interrupts must be disabled. RFLAGES.IF set to 0. Long mode enabled. Paging mode is enabled and physical memory for waking vector is identity mapped (virtual address equals physical address) Waking vector must be contained within one physical page. Selectors are set to flat and otherwise not used.
ReservedForOs	2032	16	Reserved for OS use.
ReservedForFirmware	2048	2048	Reserved for firmware use.

5.2.12.20 Core Programmable Interrupt Controller (CORE PIC) Structure

Each processor in Loongarch system has a Core Programmable Interrupt Controller record in the MADT, and a processor device object in the DSDT. The format of the CORE PIC structure is shown in the following table.

Table 5.45: CORE PIC Structure format

Field	Byte Length	Byte Offset	Description
Type	1	0	0x11 Core Programmable Interrupt Controller Structure
Length	1	1	Length of the Core Programmable Interrupt Controller Structure in bytes.
Version	1	2	0: Invalid 1: CORE PIC v1 Other values are reserved
ACPI Processor ID	4	3	The OS associates this CORE PIC Structure with a processor device object in the namespace when the _UID child object of the processor device evaluates to a numeric value that matches the numeric value in this field.
Physical Processor ID	4	7	The processor core physical id. 0xFFFFFFFF is invalid value. If invalid, this processor is unusable, and OSPM shall ignore Core Interrupt Controller Structure.
Flags	4	11	CORE PIC flags. See CORE PIC Flags for a description of this field.

Table 5.46: CORE PIC Flags

Field	Byte Length	Byte Offset	Description
Enabled	1	0	If Physical Processor ID is invalid, OSPM shall ignore this field, and OSPM shall ignore Core Programmable Interrupt Controller Structure. If Physical Processor ID is valid and if this Enabled bit is clear, this processor will be unusable on booting, and can be online during OS runtime. If Physical Processor ID is valid and if this Enabled bit is set, this processor is ready for using.
<i>Reserved</i>	31	1	Must be zero.

5.2.12.21 Legacy I/O Programmable Interrupt Controller(LIO PIC) Structure

In early Loongson CPUs, Legacy I/O Programmable Interrupt Controller (LIO PIC) routes interrupts from HT PIC to CORE PIC. The format of the LIO PIC structure is shown in the following table.

Table 5.47: LIO PIC Structure format

Field	Byte Length	Byte Offset	Description
Type	1	0	0x12 Legacy I/O Programmable Interrupt Controller Structure
Length	1	1	Length of the Legacy I/O Programmable Interrupt Controller Structure in bytes.
Version	1	2	0: Invalid 1: LIO PIC v1 Other values are reserved
Base Address	8	3	The base address of LIO PIC registers.
Size	2	11	The register space size of LIO PIC.
Cascade vector	2	13	This field described routed vectors on CORE PIC from LIO PIC vectors.
Cascade vector mapping	8	15	This field described the vectors of LIO PIC routed to the related vector of parent specified by Cascade vector field.

5.2.12.22 HyperTransport Programmable Interrupt Controller (HT PIC) Structure

In early Loongson CPUs, HT Programmable Interrupt Controller (HT PIC) routes interrupts from BIO PIC and MSI PIC to LIO PIC. The format of the HT PIC structure is shown in the following table.

Table 5.48: HT PIC Structure format

Field	Byte Length	Byte Offset	Description
Type	1	0	0x13 HT Programmable Interrupt Controller Structure
Length	1	1	Length of the HT Programmable Interrupt Controller Structure in bytes.
Version	1	2	0: Invalid 1: HT PIC v1 Other values are reserved
Base Address	8	3	The base address of HT PIC registers.
Size	2	11	The register space size of HT PIC.
Cascade vector	8	13	This field described routed vector on LIO PIC from HT PIC vectors.

5.2.12.23 Extend I/O Programmable Interrupt Controller (EIO PIC) Structure

In newer generation Loongson CPUs, Extend I/O Programmable Interrupt Controller (EIO PIC) replaces the combination of HT PIC and part of LIO PIC, and routes interrupts from BIO PIC and MSI PIC to CORE PIC directly. The format of the EIO PIC structure is shown in the following table.

Table 5.49: EIO PIC Structure format

Field	Byte Length	Byte Offset	Description
Type	1	0	0x14 Extend I/O Programmable Interrupt Controller Structure
Length	1	1	Length of the Extend I/O Programmable Interrupt Controller Structure in bytes.
Version	1	2	0: Invalid 1: EIO PIC v1 Other values are reserved
Cascade vector	1	3	This field describes routed vector on CORE PIC from EIO PIC vectors.
Node	1	4	The node ID of the node connected to bridge.
Node Map	8	5	Each bit indicates one node that can receive interrupt routing from the EIO PIC.

5.2.12.24 MSI Programmable Interrupt Controller (MSI PIC) Structure

MSI Programmable Interrupt Controller Structure is defined to support MSI of PCI/PCIE devices in system. The format of the MSI PIC structure is shown in the following table.

Table 5.50: MSI PIC Structure format

Field	Byte Length	Byte Offset	Description
Type	1	0	0x15 Message Programmable Interrupt Controller Structure
Length	1	1	Length of the Message Programmable Interrupt Controller Structure in bytes.
Version	1	2	0: Invalid 1: MSI PIC v1 Other values are reserved
Message Address	8	3	The physical address for MSI.
Start	4	11	The start vector allocated for MSI from global vectors of HT PIC or EIO PIC.
Count	4	15	The count of allocated vectors for MSI.

5.2.12.25 Bridge I/O Programmable Interrupt Controller (BIO PIC) Structure

BIO PIC (Bridge I/O Programmable Interrupt Controller) manages legacy IRQs of chipset devices, and routed them to HT PIC or EIO PIC. The format of the BIO PIC structure is shown in the following table.

Table 5.51: **BIO PIC Structure format**

Field	Byte Length	Byte Offset	Description
Type	1	0	0x16 Bridge I/O Programmable Interrupt Controller Structure
Length	1	1	Length of the Bridge I/O Programmable Interrupt Controller Structure in bytes.
Version	1	2	0: Invalid 1: BIO PIC v1 Other values are reserved
Base Address	8	3	The base address of BIO PIC registers.
Size	2	11	The register space size of BIO PIC.
Hardware ID	2	13	The hardware ID of BIO PIC.
GSI base	2	15	The global system interrupt number from which this BIO PIC's interrupt inputs start. For GSI of each interrupt input, GSI = GSI base + interrupt input vector of BIO PIC.

5.2.12.26 LPC Programmable Interrupt Controller (LPC PIC) Structure

LPC PIC (Low Pin Count Programmable Interrupt Controller) is responsible for handling ISA IRQs of old legacy devices such as PS/2 mouse, keyboard and UARTs for Loongarch machines. The format of the LPC PIC structure is shown in the following table.

Table 5.52: **LPC PIC Structure format**

Field	Byte Length	Byte Offset	Description
Type	1	0	0x17 LPC Programmable Interrupt Controller Structure
Length	1	1	Length of the LPC Programmable Interrupt Controller Structure in bytes.
Version	1	2	0: Invalid 1: LPC PIC v1 Other values are reserved
Base Address	8	3	The base address of LPC PIC registers.
Size	2	11	The register space size of LPC PIC.
Cascade vector	2	13	This field described routed vector on BIO PIC from LPC PIC vectors.

5.2.13 Global System Interrupts

Global System Interrupts can be thought of as ACPI Plug and Play IRQ numbers. They are used to virtualize interrupts in tables and in ASL methods that perform resource allocation of interrupts. Do not confuse global system interrupts with ISA IRQs although in the case of the IA-PC 8259 interrupts they correspond in a one-to-one fashion.

There are two interrupt models used in ACPI-enabled systems. The first model is the APIC model. In the APIC model, the number of interrupt inputs supported by each I/O APIC can vary. OSPM determines the mapping of the Global System Interrupts by determining how many interrupt inputs each I/O APIC supports and by determining the global system interrupt base for each I/O APIC as specified by the I/O APIC Structure. OSPM determines the number of interrupt inputs by reading the Max Redirection register from the I/O APIC. The global system interrupts mapped to that I/O APIC begin at the global system interrupt base and extending through the number of interrupts specified in the Max Redirection register. There is exactly one I/O APIC structure per I/O APIC in the system. This mapping is depicted in the following figure.

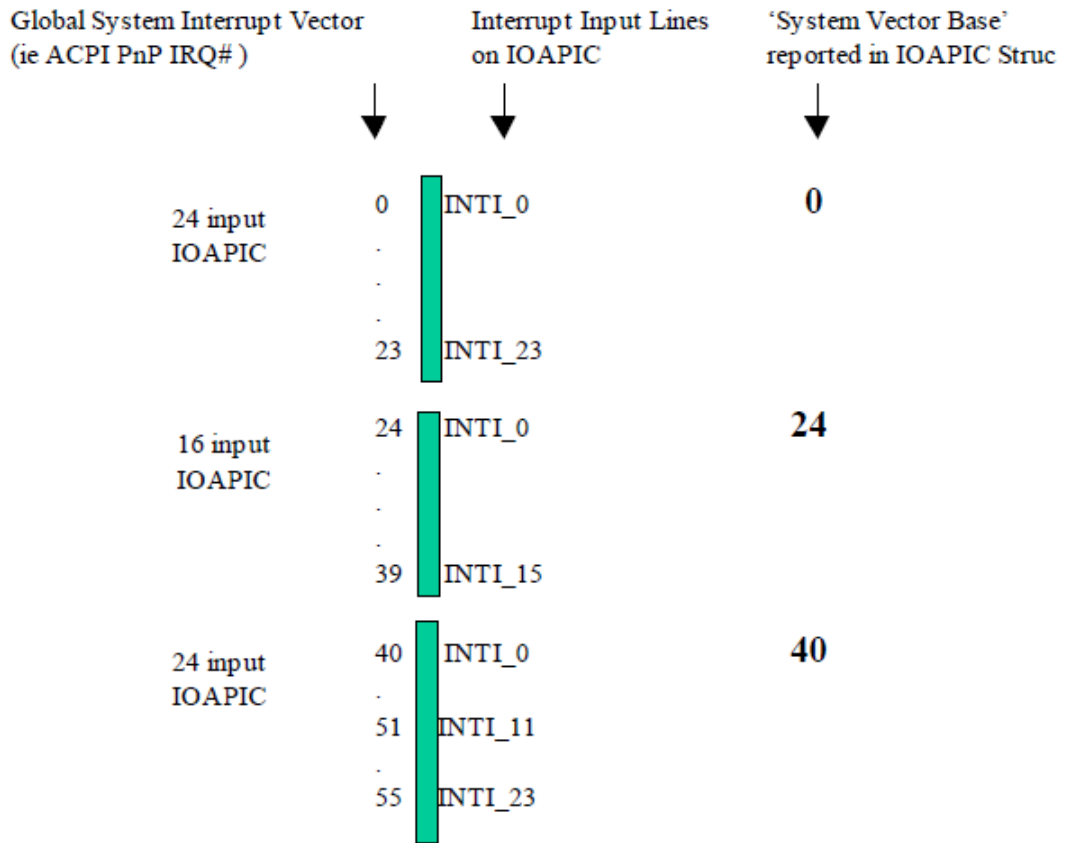

Fig. 5.3: APIC-Global System Interrupts

The other interrupt model is the standard AT style mentioned above which uses ISA IRQs attached to a master/slave pair of 8259 PICs. The system vectors correspond to the ISA IRQs. The ISA IRQs and their mappings to the 8259 pair are part of the AT standard and are well defined. This mapping is depicted in the following figure.

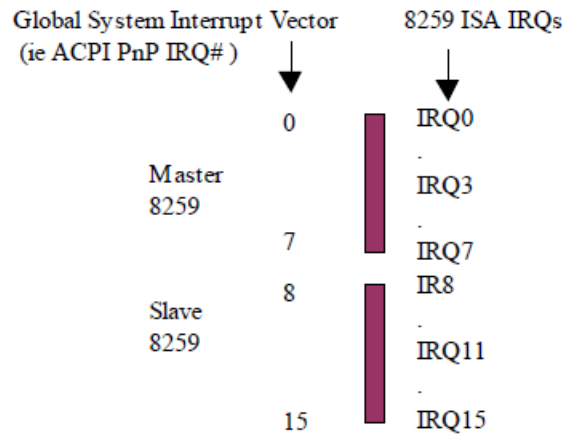

Fig. 5.4: 8259 - Global System Interrupts

5.2.14 Smart Battery Table (SBST)

If the platform supports batteries as defined by the Smart Battery Specification 1.0 or 1.1, then a Smart Battery Table (SBST) is present. This table indicates the energy level trip points that the platform requires for placing the system into the specified sleeping state and the suggested energy levels for warning the user to transition the platform into a sleeping state. Notice that while Smart Batteries can report either in current (mA/mAh) or in energy (mW/mWh), OSPM must set them to operate in energy (mW/mWh) mode so that the energy levels specified in the SBST can be used. OSPM uses these tables with the capabilities of the batteries to determine the different trip points. For more precise definitions of these levels, see Section 3.9.3

Table 5.53: Smart Battery Description Table (SBST) Format

Field	Byte Length	Byte Offset	Description
Header			
Signature	4	0	'SBST' Signature for the Smart Battery Description Table.
Length	4	4	Length, in bytes, of the entire SBST
Revision	1	8	1
Checksum	1	9	Entire table must sum to zero.
OEMID	6	10	OEM ID
OEM Table ID	8	16	For the SBST, the table ID is the manufacturer model ID.
OEM Revision	4	24	OEM revision of SBST for supplied OEM Table ID.
Creator ID	4	28	Vendor ID of utility that created the table. For tables containing Definition Blocks, this is the ID for the ASL Compiler.
Creator Revision	4	32	Revision of utility that created the table. For tables containing Definition Blocks, this is the revision for the ASL Compiler.
Warning Energy Level	4	36	OEM suggested energy level in milliWatt-hours (mWh) at which OSPM warns the user.
Low Energy Level	4	40	OEM suggested platform energy level in mWh at which OSPM will transition the system to a sleeping state.

continues on next page

Table 5.53 – continued from previous page

Field	Byte Length	Byte Offset	Description
Critical Energy Level	4	44	OEM suggested platform energy level in mWh at which OSPM performs an emergency shutdown.

5.2.15 Embedded Controller Boot Resources Table (ECDT)

This optional table provides the processor-relative, translated resources of an Embedded Controller. The presence of this table allows OSPM to provide Embedded Controller operation region space access before the namespace has been evaluated. If this table is not provided, the Embedded Controller region space will not be available until the Embedded Controller device in the AML namespace has been discovered and enumerated. The availability of the region space can be detected by providing a `_REG` method object underneath the Embedded Controller device.

Table 5.54: Embedded Controller Boot Resources Table Format

Field	Byte Length	Byte Offset	Description
Header			
Signature	4	0	'ECDT' Signature for the Embedded Controller Table.
Length	4	4	Length, in bytes, of the entire Embedded Controller Table
Revision	1	8	1
Checksum	1	9	Entire table must sum to zero.
OEMID	6	10	OEM ID
OEM Table ID	8	16	For the Embedded Controller Table, the table ID is the manufacturer model ID.
OEM Revision	4	24	OEM revision of Embedded Controller Table for supplied OEM Table ID.
Creator ID	4	28	Vendor ID of utility that created the table. For tables containing Definition Blocks, this is the ID for the ASL Compiler.
Creator Revision	4	32	Revision of utility that created the table. For tables containing Definition Blocks, this is the revision for the ASL Compiler.
EC_CONTROL	12	36	Contains the processor relative address, represented in Generic Address Structure format, of the Embedded Controller Command/Status register. Note: Only System I/O space and System Memory space are valid for values for Address_Space_ID.
EC_DATA	12	48	Contains the processor-relative address, represented in Generic Address Structure format, of the Embedded Controller Data register. Note: Only System I/O space and System Memory space are valid for values for Address_Space_ID.
UID	4	60	Unique ID-Same as the value returned by the <code>_UID</code> under the device in the namespace that represents this embedded controller.
GPE_BIT	1	64	The bit assignment of the SCI interrupt within the <code>GPEX_STS</code> register of a GPE block described in the FADT that the embedded controller triggers.
EC_ID	Variable	65	ASCII, null terminated, string that contains a fully qualified reference to the namespace object that is this embedded controller device (for example, <code>\"_SB.PCI0.ISA.EC\"</code>). Quotes are omitted in the data field.

ACPI OSPM implementations supporting Embedded Controller devices must also support the ECDT. ACPI 1.0 OSPM implementation will not recognize or make use of the ECDT. The following example code shows how to detect whether the Embedded Controller operation regions are available in a manner that is backward compatible with prior versions of ACPI/OSPM.

```

Device (EC0)
{
    Name (REGC, Ones)
    Method (_REG, 2)
    {
        If (Arg0 == 3)
        {
            REGC = Arg1
        }
    }
}

Method (ECAV, 0)
{
    If (REGC == Ones)
    {
        If (_REV >= 2)
        {
            Return (One)
        }
        Else
        {
            Return (Zero)
        }
    }
    Else
    {
        Return (REGC)
    }
}

```

To detect the availability of the region, call the ECAV method. For example:

```

If (\_SB.PCI0.EC0.ECAV())
{
    //...regions are available...
}
else
{
    //...regions are not available...
}

```

5.2.16 System Resource Affinity Table (SRAT)

This optional table provides information that allows OSPM to associate the following types of devices with system locality / proximity domains and clock domains:

- processors,
- memory ranges (including those provided by hot-added memory devices),
- generic initiators (e.g. heterogeneous processors and accelerators, GPUs, and I/O devices with integrated compute or DMA engines), and
- generic ports (e.g. host bridges that can dynamically discover new initiators and instantiate new memory range targets).

On NUMA platforms, SRAT information enables OSPM to optimally configure the operating system during a point in OS initialization when evaluation of objects in the ACPI Namespace is not yet possible.

OSPM evaluates the SRAT only during OS initialization. The Local APIC ID / Local SAPIC ID / Local x2APIC ID or the GICC ACPI Processor UID of all processors started at boot time must be present in the SRAT. If the Local APIC ID / Local SAPIC ID / Local x2APIC ID or the GICC ACPI Processor UID of a dynamically added processor is not present in the SRAT, a `_PXM` object must exist for the processor’s device or one of its ancestors in the ACPI Namespace.

Note: SRAT is the place where proximity domains are defined, and `_PXM` provides a mechanism to associate a device object (and its children) to an SRAT-defined proximity domain.

See Section 6.2.14 (`_PXM` Proximity) for more information.

Table 5.55: Static Resource Affinity Table Format

Field	Byte Length	Byte Offset	Description
Header			
Signature	4	0	‘SRAT’. Signature for the System Resource Affinity Table.
Length	4	4	Length, in bytes, of the entire SRAT. The length implies the number of Entry fields at the end of the table
Revision	1	8	3
Checksum	1	9	Entire table must sum to zero.
OEMID	6	10	OEM ID.
OEM Table ID	8	16	For the System Resource Affinity Table, the table ID is the manufacturer model ID.
OEM Revision	4	24	OEM revision of System Resource Affinity Table for supplied OEM Table ID.
Creator ID	4	28	Vendor ID of utility that created the table.
Creator Revision	4	32	Revision of utility that created the table.
<i>Reserved</i>	4	36	Reserved to be 1 for backward compatibility
<i>Reserved</i>	8	40	Reserved
Static Resource Allocation Structure[n]	—	48	A list of static resource allocation structures for the platform. See Processor Local APIC/SAPIC Affinity Structure, Memory Affinity Structure, Processor Local x2APIC Affinity Structure, and GICC Affinity Structure.

5.2.16.1 Processor Local APIC/SAPIC Affinity Structure

The Processor Local APIC/SAPIC Affinity structure provides the association between the APIC ID or SAPIC ID/EID of a processor and the proximity domain to which the processor belongs. See the Processor Local APIC/SAPIC Affinity structure.

Table 5.56: Processor Local APIC/SAPIC Affinity Structure

Field	Byte Length	Byte Offset	Description
Type	1	0	0 Processor Local APIC/SAPIC Affinity Structure
Length	1	1	16
Proximity Domain [7:0]	1	2	Bit [7:0] of the proximity domain to which the processor belongs.
APIC ID	1	3	The processor local APIC ID.
Flags	4	4	Flags - Processor Local APIC/SAPIC Affinity Structure. See Processor Local APIC/SAPIC Affinity Structure for a description of this field.
Local SAPIC EID	1	8	The processor local SAPIC EID.
Proximity Domain [31:8]	3	9	Bit [31:8] of the proximity domain to which the processor belongs.
Clock Domain	4	12	The clock domain to which the processor belongs. See <code>_CDM</code> (Clock Domain).

Table 5.57: Flags - Processor Local APIC/SAPIC Affinity Structure

Field	Bit Length	Bit Offset	Description
Enabled	1	0	If clear, the OSPM ignores the contents of the Processor Local APIC/SAPIC Affinity Structure. This allows system firmware to populate the SRAT with a static number of structures but only enable them as necessary.
<i>Reserved</i>	31	1	Must be zero.

5.2.16.2 Memory Affinity Structure

The Memory Affinity structure provides the following topology information statically to the operating system:

- The association between a memory range and the proximity domain to which it belongs
- Information about whether the memory range can be hot-plugged.

See the table below for more details.

Table 5.58: Memory Affinity Structure

Field	Byte Length	Byte Offset	Description
Type	1	0	1 Memory Affinity Structure
Length	1	1	40
Proximity Domain	4	2	Integer that represents the proximity domain to which the memory range belongs.
Reserved	2	6	Reserved
Base Address Low	4	8	Low 32 Bits of the Base Address of the memory range

continues on next page

Table 5.58 – continued from previous page

Field	Byte Length	Byte Offset	Description
Base Address High	4	12	High 32 Bits of the Base Address of the memory range
Length Low	4	16	Low 32 Bits of the length of the memory range.
Length High	4	20	High 32 Bits of the length of the memory range.
Reserved	4	24	Reserved
Flags	4	28	Flags - Memory Affinity Structure. Indicates whether the region of memory is enabled and can be hot plugged. See the corresponding table below for more details.
<i>Reserved</i>	8	32	Reserved

Table 5.59: Flags - Memory Affinity Structure

Field	Bit Length	Bit Offset	Description
Enabled	1	0	If clear, the OSPM ignores the contents of the Memory Affinity Structure. This allows system firmware to populate the SRAT with a static number of structures but only enable them as necessary.
Hot Pluggable	1	1	The information conveyed by this bit depends on the value of the Enabled bit. If the Enabled bit is set and the Hot Pluggable bit is also set. The system hardware supports hot-add and hot-remove of this memory region. If the Enabled bit is set and the Hot Pluggable bit is clear, the system hardware does not support hot-add or hot-remove of this memory region. If the Enabled bit is clear, the OSPM will ignore the contents of the Memory Affinity Structure
NonVolatile	1	2	If set, the memory region represents Non-Volatile memory
<i>Reserved</i>	29	3	Must be zero.

5.2.16.3 Processor Local x2APIC Affinity Structure

The Processor Local x2APIC Affinity structure provides the association between the local x2APIC ID of a processor and the proximity domain to which the processor belongs. Section 5.2.16.3 provides the details of the Processor Local x2APIC Affinity structure.

Table 5.60: Processor Local x2APIC Affinity Structure

Field	Byte Length	Byte Offset	Description
Type	1	0	2 Processor Local x2APIC Affinity Structure
Length	1	1	24
<i>Reserved</i>	2	2	Reserved - Must be zero
Proximity Domain	4	4	The proximity domain to which the logical processor belongs.
X2APIC ID	4	8	The processor local x2APIC ID.
Flags	4	12	Same as Processor Local APIC/SAPIC Affinity Structure flags. See the corresponding table below for a description of this field.
Clock Domain	4	16	The clock domain to which the logical processor belongs. See <i>_CDM</i> (Clock Domain).
<i>Reserved</i>	4	20	Reserved.

On x86-based platforms, the OSPM uses the Hot Pluggable bit to determine whether it should shift into PAE mode to allow for insertion of hot-plug memory with physical addresses over 4 GB.

5.2.16.4 GICC Affinity Structure

The GICC Affinity Structure provides the association between the ACPI Processor UID of a processor and the proximity domain to which the processor belongs. Section 5.2.16.4 provides the details of the GICC Affinity structure.

Table 5.61: GICC Affinity Structure

Field	Byte Length	Byte Offset	Description
Type	1	0	3 GICC Affinity Structure.
Length	1	1	18
Proximity Domain	4	2	The proximity domain to which the logical processor belongs.
ACPI Processor UID	4	6	The ACPI Processor UID of the associated GICC.
Flags	4	10	Flags - GICC Affinity Structure. See the corresponding table below for a description of this field.
Clock Domain	4	14	The clock domain to which the logical processor belongs. See <code>_CDM</code> (Clock Domain).

Table 5.62: Flags - GICC Affinity Structure

Field	Bit Length	Bit Offset	Description
Enabled	1	0	If clear, the OSPM ignores the contents of the GICC Affinity Structure. This allows system firmware to populate the SRAT with a static number of structures but only enable them as necessary.
Reserved	31	1	Must be zero.

5.2.16.5 GIC Interrupt Translation Service (ITS) Affinity Structure

The GIC ITS Affinity Structure provides the association between a GIC ITS and a proximity domain. This enables the OSPM to discover the memory that is closest to the ITS, and use that in allocating its management tables and command queue. The ITS is identified using an ID matching a declaration of a GIC ITS in the MADT, see Section 5.2.12.18 for details. The following table provides the details of the GIC ITS Affinity structure.

Table 5.63: Architecture Specific Affinity Structure

Field	Byte Length	Byte Offset	Description
Type	1	0	4 GIC ITS Affinity Structure
Length	1	1	12
Proximity domain	4	2	Integer that represents the proximity domain to which the GIC ITS belongs to.
Reserved	2	6	Reserved must be zero
ITS ID	4	8	ITS ID matching a GIC ITS entry in the MADT

5.2.16.6 Generic Initiator Affinity Structure

The Generic Initiator Affinity Structure provides the association between a generic initiator and the proximity domain to which the initiator belongs.

Support of Generic Initiator Affinity Structures by OSPM is optional, and the platform may query whether the OS supports it via the _OSC method. See Section 6.2.11.2 for more details.

Table 5.64: Generic Initiator Affinity Structure

Field	Byte Length	Byte Offset	Description
Type	1	0	5 Generic Initiator Structure.
Length	1	1	32
Reserved	1	2	Reserved and must be zero.
Device Handle Type	1	3	Device Handle Type: 0 - ACPI Device Handle 1 - PCI Device Handle 2-255 - Reserved
Proximity Domain	4	4	The proximity domain to which the generic initiator belongs.
Device Handle	16	8	Device Handle of the Generic Initiator. See Device Handle - ACPI for a description of the ACPI Device Handle, and Device Handle - PCI for a description of the PCI Device Handle.
Flags	4	24	Flags - Generic Initiator/Port Affinity Structure. See Section 5.2.16.7 for a description of this field.
Reserved	4	28	Reserved and must be zero.

Table 5.65: Device Handle - ACPI

Field	Byte Length	Byte Offset	Description
ACPI _HID	8	0	The _HID value
ACPI _UID	4	8	The _UID value
Reserved	4	12	Must be zero.

Table 5.66: Device Handle - PCI

Field	Byte Length	Byte Offset	Description
PCI Segment	2	0	PCI segment number. For systems with fewer than 255 PCI buses, this number must be 0.
PCI BDF Number	2	2	PCI Bus Number (Bits 7:0 of Byte 2) PCI Device Number (Bits 7:3 of Byte 3) PCI Function Number (Bits 2:0 of Byte 3)
Reserved	12	4	Must be zero

5.2.16.7 Generic Port Affinity Structure

The Generic Port Affinity Structure provides an association between a proximity domain number and a device handle representing a Generic Port (e.g. CXL Host Bridge, or similar device that hosts a dynamic topology of memory ranges and/or initiators).

Support of Generic Port Affinity Structures by an OSPM is optional.

Table 5.67: Generic Port Affinity Structure Table

Field	Byte Length	Byte Offset	Description
Type	1	0	6 Generic Port Structure
Length	1	1	32
Reserved	1	2	Reserved and must be zero.
Device Handle Type	1	3	Device Handle Type: See Section 5.2.16.6 for the possible device handle types and their format.
Proximity Domain	4	4	The proximity domain to identify the performance of this port in the HMAT.
Device Handle	16	8	Device Handle of the Generic Port: see Table 5.65 and Table 5.66 for a description of this field.
Flags	4	24	See Table 5.68 for a description of this field.
Reserved	4	28	Reserved and must be zero.

Table 5.68: Flags - Generic Initiator/Port Affinity Structure

Field	Bit Length	Bit Offset	Description
Enabled	1	0	If clear, the OSPM ignores the contents of the Generic Initiator/Port Affinity Structure. This allows system firmware to populate the SRAT with a static number of structures, but only enable them as necessary.
Architectural transactions	1	1	If set, indicates that the Generic Initiator/Port can initiate all transactions at the same architectural level as the host (e.g. full atomicOps, cache coherency, virtual memory, etc.) See implementation note following.
Reserved	30	2	Must be zero.

Note: If a generic device with coherent memory is attached to the system, it is recommended to define affinity structures for both the device and memory associated with the device. They both may have the same proximity domain.

If a generic device is marked with “architectural transactions,” the Generic Initiator supports all applicable architectural mechanisms for cache synchronization, atomicOps and virtual memory, etc. - fully equivalent to the memory model of the host processor (with potentially different but equivalent instruction mechanisms in its ISA).

Supporting a subset of architectural transactions would be only permissible if the lack of the feature does not have material consequences to the memory model. One example is lack of cache coherency support on the GI, if the GI does not have any local caches to global memory that require invalidation through the data fabric.

OS is assured that the GI adheres to the memory model as the host processor architecture related to observable transactions to memory for memory fences and other synchronization operations issued on either initiator or host.

5.2.17 System Locality Information Table (SLIT)

This optional table provides a matrix that describes the relative distance (memory latency) between all System Localities, which are also referred to as Proximity Domains. Systems employing a Non Uniform Memory Access (NUMA) architecture contain collections of hardware resources including for example, processors, memory, and I/O buses, that comprise what is known as a “NUMA node”. Processor accesses to memory or I/O resources within the local NUMA node is generally faster than processor accesses to memory or I/O resources outside of the local NUMA node.

The value of each Entry[i,j] in the SLIT table, where i represents a row of a matrix and j represents a column of a matrix, indicates the relative distances from System Locality / Proximity Domain i to every other System Locality j in the system (including itself).

The i,j row and column values correlate to Proximity Domain values in the System Resource Affinity Table (SRAT), and to values returned by _PXM objects in the ACPI namespace. See Section 5.2.16 for more information.

The entry value is a one-byte unsigned integer. The relative distance from System Locality i to System Locality j is the i*N + j entry in the matrix, where N is the number of System Localities. Except for the relative distance from a System Locality to itself, each relative distance is stored twice in the matrix. This provides the capability to describe the scenario where the relative distances for the two directions between System Localities is different.

The diagonal elements of the matrix, the relative distances from a System Locality to itself are normalized to a value of 10. The relative distances for the non-diagonal elements are scaled to be relative to 10. For example, if the relative distance from System Locality i to System Locality j is 2.4, a value of 24 is stored in table entry i*N+ j and in j*N+ i, where N is the number of System Localities.

If one locality is unreachable from another, a value of 255 (0xFF) is stored in that table entry. Distance values of 0-9 are reserved and have no meaning.

Table 5.69: SLIT Format

Field	Byte Length	Byte Offset	Description
Header			
- Signature	4	0	‘SLIT’. Signature for the System Locality Distance Information Table.
- Length	4	4	Length, in bytes, of the entire System Locality Distance Information Table.
- Revision	1	8	1
- Checksum	1	9	Entire table must sum to zero.
- OEMID	6	10	OEM ID.
- OEM Table ID	8	16	For the System Locality Information Table, the table ID is the manufacturer model ID.
- OEM Revision	4	24	OEM revision of System Locality Information Table for supplied OEM Table ID.
- Creator ID	4	28	Vendor ID of utility that created the table. For the DSDT, RSDT, SSDT, and PSDT tables, this is the ID for the ASL Compiler.
- Creator Revision	4	32	Revision of utility that created the table. For the DSDT, RSDT, SSDT, and PSDT tables, this is the revision for the ASL Compiler.
Number of System Localities	8	36	Indicates the number of System Localities in the system.
Entry[0][0]	1	44	Matrix entry (0,0), contains a value of 10.
...			...

continues on next page

Table 5.69 – continued from previous page

Field	Byte Length	Byte Offset	Description
Entry[0][Number of System Localities-1]	1		Matrix entry (0, Number of System Localities-1)
Entry[1][0]	1		Matrix entry (1,0)
...			...
Entry [Number of System Localities-1] [Number of System Localities-1]	1		Matrix entry (Number of System Localities-1, Number of System Localities-1), contains a value of 10

5.2.18 Corrected Platform Error Polling Table (CPEP)

Platforms may contain the ability to detect and correct certain operational errors while maintaining platform function. These errors may be logged by the platform for the purpose of retrieval. Depending on the underlying hardware support, the means for retrieving corrected platform error information varies. If the platform hardware supports interrupt-based signaling of corrected platform errors, the MADT Platform Interrupt Source Structure describes the Corrected Platform Error Interrupt (CPEI). See [Section 5.2.12.11](#). Alternatively, OSPM may poll processors for corrected platform error information. Error log information retrieved from a processor may contain information for all processors within an error reporting group. As such, it may not be necessary for OSPM to poll all processors in the system to retrieve complete error information. This optional table provides information that allows OSPM to poll only the processors necessary for a complete report of the platform's corrected platform error information.

Table 5.70: Corrected Platform Error Polling Table Format

Field	Byte Length	Byte Offset	Description
Header			
- Signature	4	0	'CPEP'. Signature for the Corrected Platform Error Polling Table.
- Length	4	4	Length, in bytes, of the entire CPET. The length implies the number of Entry fields at the end of the table
- Revision	1	8	1
- Checksum	1	9	Entire table must sum to zero.
- OEMID	6	10	OEM ID.
- OEM Table ID	8	16	For the Corrected Platform Error Polling Table, the table ID is the manufacturer model ID.
- OEM Revision	4	24	OEM revision of Corrected Platform Error Polling Table for supplied OEM Table ID.
- Creator ID	4	28	Vendor ID of utility that created the table.
- Creator Revision	4	32	Revision of utility that created the table.
<i>Reserved</i>	8	36	Reserved, must be 0.
CPEP Processor Structure[n]	—	44	A list of Corrected Platform Error Polling Processor structures for the platform. See corresponding table below.

5.2.18.1 Corrected Platform Error Polling Processor Structure

The Corrected Platform Error Polling Processor structure provides information on the specific processors OSPM polls for error information. See corresponding table below for details of the Corrected Platform Error Polling Processor structure.

Table 5.71: Corrected Platform Error Polling Processor Structure

Field	Byte Length	Byte Offset	Description
Type	1	0	0 Corrected Platform Error Polling Processor structure for APIC/SAPIC based processors
Length	1	1	8
Processor ID	1	2	Processor ID of destination.
Processor EID	1	3	Processor EID of destination.
Polling Interval	4	4	Platform-suggested polling interval (in milliseconds)

5.2.19 Maximum System Characteristics Table (MSCT)

This section describes the format of the Maximum System Characteristic Table (MSCT), which provides OSPM with information characteristics of a system's maximum topology capabilities. If the system maximum topology is not known up front at boot time, then this table is not present. OSPM will use information provided by the MSCT only when the System Resource Affinity Table (SRAT) exists. The MSCT must contain all proximity and clock domains defined in the SRAT.

Table 5.72: Maximum System Characteristics Table (MSCT) Format

Field	Byte Length	Byte Off-set	Description
Header			
- Signature	4	0	'MSCT' Signature for the Maximum System Characteristics Table.
Length	4	4	Length, in bytes, of the entire MSCT.
Revision	1	8	1
Checksum	1	9	Entire table must sum to zero.
OEMID	6	10	OEM ID
OEM Table ID	8	16	For the MSCT, the table ID is the manufacturer model ID.
OEM Revision	4	24	OEM revision of MSCT for supplied OEM Table ID.
Creator ID	4	28	Vendor ID of utility that created the table. For tables containing Definition Blocks, this is the ID for the ASL Compiler.
Creator Revision	4	32	Revision of utility that created the table. For tables containing Definition Blocks, this is the revision for the ASL Compiler.
Offset to Proximity Domain Information Structure [OffsetProxDomInfo]	4	36	Offset in bytes to the Proximity Domain Information Structure table entry.
Maximum Number of Proximity Domains	4	40	Indicates the maximum number of Proximity Domains ever possible in the system. The number reported in this field is (maximum domains - 1). For example if there are 0x10000 possible domains in the system, this field would report 0xFFFF.
Maximum Number of Clock Domains	4	44	Indicates the maximum number of Clock Domains ever possible in the system. The number reported in this field is (maximum domains - 1). See Section 6.2.1 .
Maximum Physical Address	8	48	Indicates the maximum Physical Address ever possible in the system. Note: this is the top of the reachable physical address.
Proximity Domain Information Structure[Maximum Number of Proximity Domains]	-	[OffsetProxDomInfo]	A list of Proximity Domain Information for this implementation. The structure format is defined in the Maximum Proximity Domain Information Structure section.

5.2.19.1 Maximum Proximity Domain Information Structure

The Maximum Proximity Domain Information Structure is used to report system maximum characteristics. It is likely that these characteristics may be the same for many proximity domains, but they can vary from one proximity domain to another. This structure optimizes to cover the former case, while allowing the flexibility for the latter as well. These structures must be organized in ascending order of the proximity domain enumerations. All proximity domains within the Maximum Number of Proximity Domains reported in the MSCT must be covered by one of these structures.

Table 5.73: Maximum Proximity Domain Information Structure

Field	Byte Length	Byte Offset	Description
Revision	1	0	1
Length	1	1	22
Proximity Domain Range (low)	4	2	The starting proximity domain for the proximity domain range that this structure is providing information.
Proximity Domain Range (high)	4	6	The ending proximity domain for the proximity domain range that this structure is providing information.
Maximum Processor Capacity	4	10	The Maximum Processor Capacity of each of the Proximity Domains specified in the range. A value of 0 means that the proximity domains do not contain processors. This field must be \geq the number of processor entries for the domain in the SRAT.
Maximum Memory Capacity	8	14	The Maximum Memory Capacity (size in bytes) of the Proximity Domains specified in the range. A value of 0 means that the proximity domains do not contain memory.

5.2.20 ACPI RAS Feature Table (RASf)

The following table describes the structure of ACPI RAS Feature Table.

Table 5.74: RASf Table format

Field	Byte Length	Byte Offset	Description
Header			
- Signature	4	0	'RASf' is Signature for RAS Feature Table
- Length	4	4	Length in bytes for entire RASf. The length implies the number of Entry fields at the end of the table
- Revision	1	8	1
- Checksum	1	9	Entire table must sum to zero
- OEMID	6	10	OEM ID
- OEM Table ID	8	16	The table ID is the manufacturer model ID
- OEM Revision	4	24	OEM revision of table for supplied OEM Table ID
- Creator ID	4	28	Vendor ID of utility that created the table
- Creator Revision	4	32	Revision of utility that created the table
RASf Specific Entries			
- RASf Platform Communication Channel Identifier	12	36	Identifier of the RASf Platform Communication Channel. OSPM should use this value to identify the PCC Sub channel structure in the RASf table

5.2.20.1 RASF PCC Sub Channel Identifier

RASF PCC Sub Channel Identifier is used by the OSPM to identify the PCC Sub channel structure. RASF table references its PCC Subspace by this identifier as shown in [Table 5.74](#).

5.2.20.2 Using PCC registers

OSPM will write PCC registers by filling in the register value in PCC sub channel space and issuing a PCC Execute command. See [Table 5.76](#).

To minimize the cost of PCC transactions, OSPM should read or write all registers in the same PCC subspace via a single read or write command.

5.2.20.3 RASF Communication Channel

RASF Action Entries are defined in the PCC sub channel as below.

Table 5.75: RASF Platform Communication Channel Shared Memory Region

Field	Byte Length	Byte Offset	Description
<i>Signature</i>	4	0	The PCC Signature of 0x52415346 (corresponds to ASCII signature of RASF)
<i>Command</i>	2	4	PCC command field; see PCC Command Codes used by RASF Platform Communication Channel, and the Platform Communications Channel (PCC).
<i>Status</i>	2	6	PCC status field. See Platform Communications Channel (PCC).
Communication Space:			
<i>Version</i>	2	8	Byte 0 - Minor Version Byte 1 - Major Version
<i>RAS Capabilities</i>	16	10	Bit Map describing the platform RAS capabilities as shown in Platform RAS Capabilities. The Platform populates this field. The OSPM uses this field to determine the RAS capabilities of the platform.
<i>Set RAS Capabilities</i>	16	26	Bit Map of the RAS features for which the OSPM is invoking the command. The Bit Map is described in Section 5.2.20.4 . OSPM sets the bit corresponding to a RAS capability to invoke a command on that capability. The bitmap implementation allows OSPM to invoke a command on each RAS feature supported by the platform at the same time.
<i>Number of RASF Parameter blocks</i>	2	42	The Number of parameter blocks will depend on how many RAS Capabilities the Platform Supports. Typically, there will be one Parameter Block per RAS Feature, using which that feature can be managed by OSPM.

continues on next page

Table 5.75 – continued from previous page

Field	Byte Length	Byte Offset	Description
<i>Set RAS Capabilities Status</i>	4	44	Status: 0000b = Success 0001b = Not Valid 0010b = Not Supported 0011b = Busy 0100b = FailedF 0101b = Aborted 0110b = Invalid Data
<i>Parameter Blocks</i>	Varies (N Bytes)	48	Start of the parameter blocks, the structure of which is shown in the Parameter Block Structure for PATROL_SCRUB. These parameter blocks are used as communication mailbox between the OSPM and the platform, and there is 1 parameter block for each RAS feature. NOTE: There can be only on parameter block per type.

Table 5.76: PCC Command Codes used by RASF Platform Communication Channel

Command	Description
0x00	Reserved
0x01	Execute RASF Command.
0x02-0xFF	All other values are reserved.

5.2.20.4 Platform RAS Capabilities

The following table defines the Platform RAS capabilities:

Table 5.77: Platform RAS Capabilities Bitmap

Bit	RAS Feature	Description
0	Hardware based patrol scrub supported	Indicates that the platform supports hardware based patrol scrub of DRAM memory
1	Hardware based patrol scrub supported and exposed to software	Indicates that the platform supports hardware based patrol scrub of DRAM memory and platform exposes this capability to software using this RASF mechanism
2-127	<i>Reserved</i>	Reserved for future use

5.2.20.5 Parameter Block

The following table describes the Parameter Blocks. The structure is used to pass parameters for controlling the corresponding RAS Feature.

Each RAS Feature is assigned a TYPE number, which is the bit index into the RAS capabilities bitmap described in Table 5.77 .

Table 5.78: Parameter Block Structure for PATROL_SCRUB

Field	Byte Length	Byte Offset	Description
Type	2	0	0x0000 - Patrol scrub
Version	2	2	Byte 0 - Minor Version Byte 1 - Major Version
Length	2	4	Length, in bytes of the entire parameter block structure
Patrol Scrub Command (INPUT)	2	6	0x01 - GET_PATROL_PARAMETERS 0x02 - START_PATROL_SCRUBBER 0x03 - STOP_PATROL_SCRUBBER
Requested Address Range(INPUT)	16	8	OSPM Specifies the BASE (Bytes 7-0) and SIZE (Bytes 15-8) of the address range to be patrol scrubbed. OSPM sets this parameter for the following commands: GET_PATROL_PARAMETERS and START_PATROL_SCRUBBER
Actual Address Range (OUTPUT)	16	24	The platform returns this value in response to GET_PATROL_PARAMETERS. The platform calculates the nearest patrol scrub boundary address from where it can start. This range should be a superset of the Requested Address Range. BASE (Bytes 7-0) and SIZE (Bytes 15-8) of the address
Flags (OUTPUT)	2	40	The platform returns this value in response to GET_PATROL_PARAMETERS: Bit [0]: Will be set if patrol scrubber is already running for address range specified in “Actual Address Range” Bits [3:1]: Current Patrol Speeds, if Bit [0] is set: 000b - Slow 100b - Medium 111b - Fast All other combinations are reserved. Bits [15:4]: RESERVED

continues on next page

Table 5.78 – continued from previous page

Requested Speed (INPUT)	1	42	<p>The OSPM Sets this field as follows, for the START_PATROL_SCRUBBER command:</p> <p>Bit [0]: Will be set if patrol scrubber is already running for address range specified in “Actual Address Range”</p> <p>Bits [2:0]: Requested Patrol Speeds</p> <p>000b - Slow</p> <p>100b - Medium</p> <p>111b - Fast</p> <p>All other combinations are reserved.</p> <p>Bits [7:3]: RESERVED</p>
-------------------------	---	----	--

5.2.20.5.1 Sequence of Operations:

The following sequence documents the steps for OSPM to identify whether the platform supports hardware based patrol scrub and invoke commands to request hardware to patrol scrub the specified address range.

1. Identify whether the platform supports hardware based patrol scrub and exposes the support to software by reading the RAS capabilities bitmap in the RASF table.
2. Call GET_PATROL_PARAMETERS, by setting the Requested Address Range.
3. Platform Returns Actual Address Range and Flags.
4. Based on the above two data, if the OPSM decides to start the patrol scrubber or change the speed of the patrol scrubber, then the OSPM calls START_PATROL_SCRUBBER, by setting the Requested Address Range and Requested Speed.

5.2.21 ACPI RAS2 Feature Table (RAS2)

The RAS2 table provides interfaces for platform RAS features. RAS2 offers the same services as RASF, but is more scalable than the latter. In particular, RAS2 supports independent RAS controls and capabilities for a given RAS feature for multiple instances of the same component in a given system.

The platform can support either RAS2 or RASF but not both.

Table 5.79: RAS2 Table format

Field	Byte Length	Byte Offset	Description
Header			
- Signature	4	0	Signature is set to ‘RAS2’ for RAS Feature 2 Table.
- Length	4	4	Length in bytes for entire RAS2. The length implies the number of PCC descriptors fields at the end of the table
- Revision	1	8	1
- Checksum	1	9	Entire table must sum to zero
- OEMID	6	10	OEM ID
- OEM Table ID	8	16	The table ID is the manufacturer model ID
- OEM Revision	4	24	OEM revision of table for supplied OEM Table ID

continues on next page

Table 5.79 – continued from previous page

- Creator ID	4	28	Vendor ID of utility that created the table
- Creator Revision	4	32	Revision of utility that created the table
RAS2 Specific Entries			
- <i>Reserved</i>	2	36	Reserved, should be zero.
- Number of PCC descriptors	2	38	Number of PCC descriptors.
- RAS2 Platform Communication Channel (PCC) Descriptor List	N*8	40	List of PCC descriptors.

5.2.21.1 Common Definitions

5.2.21.1.1 RAS2 Platform Communication Channel Descriptor

RAS2 supports multiple PCC channels, where a channel is dedicated to a given component instance. The RAS2 PCC descriptor specifies the PCC sub-space associated with a specific RAS feature. The RAS feature type specifies the RAS feature.

Table 5.80: RAS2 Platform Communication Channel Descriptor format

Field	Byte Length	Byte Offset	Description
PCC Identifier	1	0	Identifier of the RAS2 Platform Communication Channel. OSPM should use this value as an index into the subspace array within the PCCT table.
<i>Reserved</i>	2	1	Reserved, must be zero.
Feature Type	1	3	RAS feature type. RAS feature types are defined in Table 5.81.
Instance	4	4	Identifier for the system component instance that this RAS feature is associated with.

Table 5.81: RAS Feature Types

RAS Feature Type	Description
0x00	RAS features related to memory.
0x01-0x7F	Reserved for future standard RAS feature types defined by this specification.
0x80-0xFF	Vendor-defined RAS feature types.

5.2.21.1.2 Using PCC Registers

OSPM will write PCC registers by filling in the register value in PCC sub channel space and issuing a PCC Execute command (see Table 5.82). To minimize the cost of PCC transactions, OSPM should read or write all registers in the same PCC subspace via a single read or write command.

Table 5.82: PCC Command Codes used by RAS2 Platform Communication Channel

Command	Description
0x00	<i>Reserved</i>
0x01	Execute RAS2 Command.
0x02-0xFF	All other values are reserved.

5.2.21.1.3 RAS2 Platform Communication Channel

The RAS2 platform communication channel format is defined below (Table 5.83).

Table 5.83: RAS2 Platform Communication Channel Shared Memory Region

Field	Byte Length	Byte Offset	Description
Signature	4	0	The PCC signature. The signature of a subspace is computed by a bitwise-or of the value 0x50434300 with the subspace ID. For example, subspace 3 has the signature 0x50434303.
Command	2	4	PCC command field; see PCC Command Codes used by RAS2. See Table 5.82 and Section 14.
Status	2	6	PCC status field. See Section 14.
Communication Space			
- Version	2	8	Byte 0 - Minor Version Byte 1 - Major Version For this revision, this field must be set to 0x0000
- RAS Features	16	10	Bitmap describing the platform RAS features as shown in Table 5.84. The definition of the bits is system component specific. For example, Table 5.86 shows the bitmap definitions for Memory RAS features. The Platform populates this field to indicate which RAS features for the given feature type are supported for this system component instance. The OSPM uses this field for RAS feature discovery.
- Set RAS Capabilities	16	26	Bit Map of the RAS features for which the OSPM is invoking the command. The Bit Map is described in Section 5.2.21.1.4. OSPM sets the bit corresponding to a RAS capability to invoke a command on that capability. The bitmap implementation allows OSPM to invoke a command on each RAS feature supported by the platform at the same time. {need links}
- Number of RAS2 Parameter Blocks	2	42	The Number of parameter blocks will depend on how many RAS Capabilities the Platform Supports. Typically, there will be one Parameter Block per RAS Feature, using which that feature can be managed by OSPM.

continues on next page

Table 5.83 – continued from previous page

- Set RAS Capabilities Status	4	44	Status: 0000b = Success 0001b = Not Valid 0010b = Not Supported 0011b = Busy 0100b = FailedF 0101b = Aborted 0110b = Invalid Data
- Parameter Blocks	Varies (N bytes)	48	Start of the parameter blocks, the structure of which is shown in the Parameter Block Structure for PATROL_SCRUB. These parameter blocks are used as communication mailbox between the OSPM and the platform, and there is 1 parameter block for each RAS feature. NOTE: There can be only one parameter block per type.

5.2.21.1.4 RAS2 Platform RAS Feature Bitmap (generic)

The following table (Table 5.84) shows a generic definition of the Platform RAS features supported for a given system component type. The exact definitions are specific for each system component type. For example, Table 5.86 shows the bitmap definitions for Memory RAS features.

Table 5.84: Platform RAS Feature Bitmap

Bit	RAS feature	Description
0	Feature 1	RAS Feature 1
1	Feature 2	RAS Feature 2
...
127	Feature 128	RAS Feature 128

5.2.21.2 Memory RAS Features – Feature Type 0

Memory RAS features apply to RAS capabilities, controls and operations that are specific to memory. These features might be provided through one or more PCC sub-spaces. RAS2 sub-spaces for memory-specific RAS features have a Feature Type of 0x00 (Memory).

Table 5.85: RAS2 Platform Communication Channel Descriptor for Memory RAS Features

Field	Byte Length	Byte Offset	Description
PCC Identifier	1	0	Identifier of the RAS2 Platform Communication Channel. OSPM should use this value as an index into the subspace array within the PCCT table.
<i>Reserved</i>	2	1	0
Feature Type	1	3	0x00: Memory. See Table 5.81

continues on next page

Table 5.85 – continued from previous page

Instance	4	4	Proximity domain that this RAS feature is associated with. This field must match the ACPI SRAT table definitions. See Section 5.2.16.
----------	---	---	---

Table 5.86: Platform RAS Feature Bitmap for Memory RAS

Bit	RAS Feature	Feature Name	Description
0	Hardware-based memory scrub feature	PATROL_SCRUB	Indicates that the platform supports hardware-based memory scrubbing. OSPM must set this bit in the Set RAS Capabilities field to request memory scrubbing service.
1	Logical to Physical Address translation feature	LA2PA_TRANSLATION	Indicates that the platform supports logical address to physical address translation service. OSPM must set this bit in the Set RAS Capabilities field to request address translation for a logical address.
2-127	<i>Reserved</i>		<i>Reserved for future use</i>

5.2.21.2.1 Hardware-based Memory Scrubbing

The platform can use this feature to expose controls and capabilities associated with hardware-based memory scrub engines. Modern scalable platforms have complex memory systems with a multitude of memory controllers that are in turn associated with NUMA domains. It is also common for RAS errors related to memory to be associated with NUMA domains, where the NUMA domain functions as a FRU identifier. This feature thus provides memory scrubbing at a NUMA domain granularity.

The following are supported:

- Independent memory scrubbing controls for each NUMA domain, identified using its proximity domain.
- Provision for background (patrol) scrubbing of the entire memory system, as well as on-demand scrubbing for a specific region of memory.

Table 5.87: Parameter Block Structure for PATROL_SCRUB

Field	Byte Length	Byte Offset	Description
Type	2	0	0x0000 – Hardware-based memory scrub RAS feature.
Version	2	2	Byte 0 - Minor Version Byte 1 - Major Version For this format of the parameter block, this field should be set to 0x0001.
Length	2	4	Length, in bytes of the entire parameter block structure
Patrol Scrub Command (INPUT)	2	6	0x01 - GET_PATROL_PARAMETERS 0x02 - START_PATROL_SCRUBBER 0x03 - STOP_PATROL_SCRUBBER

continues on next page

Table 5.87 – continued from previous page

Requested Address Range(INPUT)	16	8	<p>OSPM Specifies the BASE (Bytes 7-0) and SIZE (Bytes 15-8) of the address range to be patrol scrubbed. If OSPM requests default scrubbing through Bit 0 of the Configure patrol scrubbing field, then this field must be ignored by the platform.</p> <p>OSPM sets this parameter for the following commands: GET_PATROL_PARAMETERS, START_PATROL_SCRUBBER.</p>
Actual Address Range (OUTPUT)	16	24	<p>The platform returns this value in response to GET_PATROL_PARAMETERS. The platform calculates the nearest patrol scrub boundary address from where it can start. This range should be a superset of the Requested Address Range.</p> <p>This field must be ignored by the OSPM if it is being returned in response to a request to enable default scrubbing through Bit 0 of the Configure patrol scrubbing field.</p> <p>BASE (Bytes 7-0) and SIZE (Bytes 15-8) of the address.</p>
Flags (OUTPUT)	4	40	<p>The platform returns this value in response to GET_PATROL_PARAMETERS:</p> <p>Bit [0]: Will be set if memory scrubber is already running for address range specified in “Actual Address Range”.</p> <p>Bits [31:1]: Reserved, must be zero.</p>
Scrub Parameters (OUTPUT)	4	44	<p>The platform returns this value in response to GET_PATROL_PARAMETERS:</p> <p>Bits [7:0]: Current scrub rate that is in effect on the memory region specified in “Actual Address Range”. If OSPM requested background scrubbing, then this field will reflect the current background patrol scrubbing rate.</p> <p>Bits [15:8]: Minimum scrub rate supported.</p> <p>Bits [23:16]: Maximum scrub rate supported</p> <p>Bits [31:24]: Reserved, must be zero.</p>

continues on next page

Table 5.87 – continued from previous page

Configure Scrub Parameters (INPUT)	4	48	<p>The OSPM Sets this field as follows, for the START_PATROL_SCRUBBER command:</p> <p>Bit[0]: Request background patrol scrubbing.</p> <p>Bits [7:1]: Reserved, must be zero.</p> <p>Bits [15:8]: Requested scrub rate, must be in the range (minimum scrub rate, maximum scrub rate).</p> <p>Bits [31:16]: Reserved, must be zero.</p>
------------------------------------	---	----	---

5.2.21.2.2 Logical to Physical Address Translation Service

The platform can use this feature to provide support for translation of logical addresses to physical addresses. In some platform implementations, individual components in the platform may be restricted to a local view of memory. When these components detect and log an error, they may be limited to only recording the logical address of the error. However, the OSPM requires addresses in the global, physical address space so that it can perform error recovery and isolation. This service provides the address translation required for this purpose.

Table 5.88: Parameter Block Structure for LA2PA_TRANSLATION

Field	Byte Length	Byte Offset	Description
Type	2	0	0x0001 – LA to PA address translation service
Version	2	2	Byte 0 - Minor Version Byte 1 - Major Version For this format of the parameter block, this field should be set to 0x0001.
Length	2	4	Length, in bytes of the entire parameter block structure
Address Translation Command (INPUT)	2	6	0x01 - GET_LA2PA_TRANSLATION
Sub-instance Identifier	8	8	If there are multiple constituent components that fall within the proximity domain, this field can be used to point to the specific component to which the LA applies.
Logical Address (INPUT)	8	16	OSPM specifies the logical address in this field the GET_LA2PA_TRANSLATION command.
Physical Address (OUTPUT)	8	24	The platform returns the physical address in this field in response to GET_LA2PA_TRANSLATION.

continues on next page

Table 5.88 – continued from previous page

Status (OUTPUT)	4	32	<p>The platform returns this value in response to GET_LA2PA_TRANSLATION:</p> <p>0x0000_0000: Indicates that the translation succeeded.</p> <p>0x0000_0001: Indicates that the translation failed, and the Physical Address returned by the platform may not be valid.</p> <p>Other values are reserved for future use by this specification.</p>
-----------------	---	----	--

5.2.22 Memory Power State Table (MPST)

The following table describes the structure of new ACPI memory power state table (MPST). This table defines the memory power node topology of the configuration, as described earlier in [Section 1](#) . The configuration includes specifying memory power nodes and their associated information. Each memory power node is specified using address ranges, supported memory power states. The memory power states will include both hardware controlled and software controlled memory power states. There can be multiple entries for a given memory power node to support non contiguous address ranges. MPST table also defines the communication mechanism between OSPM and platform runtime firmware for triggering software controlled memory powerstate transitions implemented in platform runtime firmware.

The following figure provides a structured organization overview of MPST table.

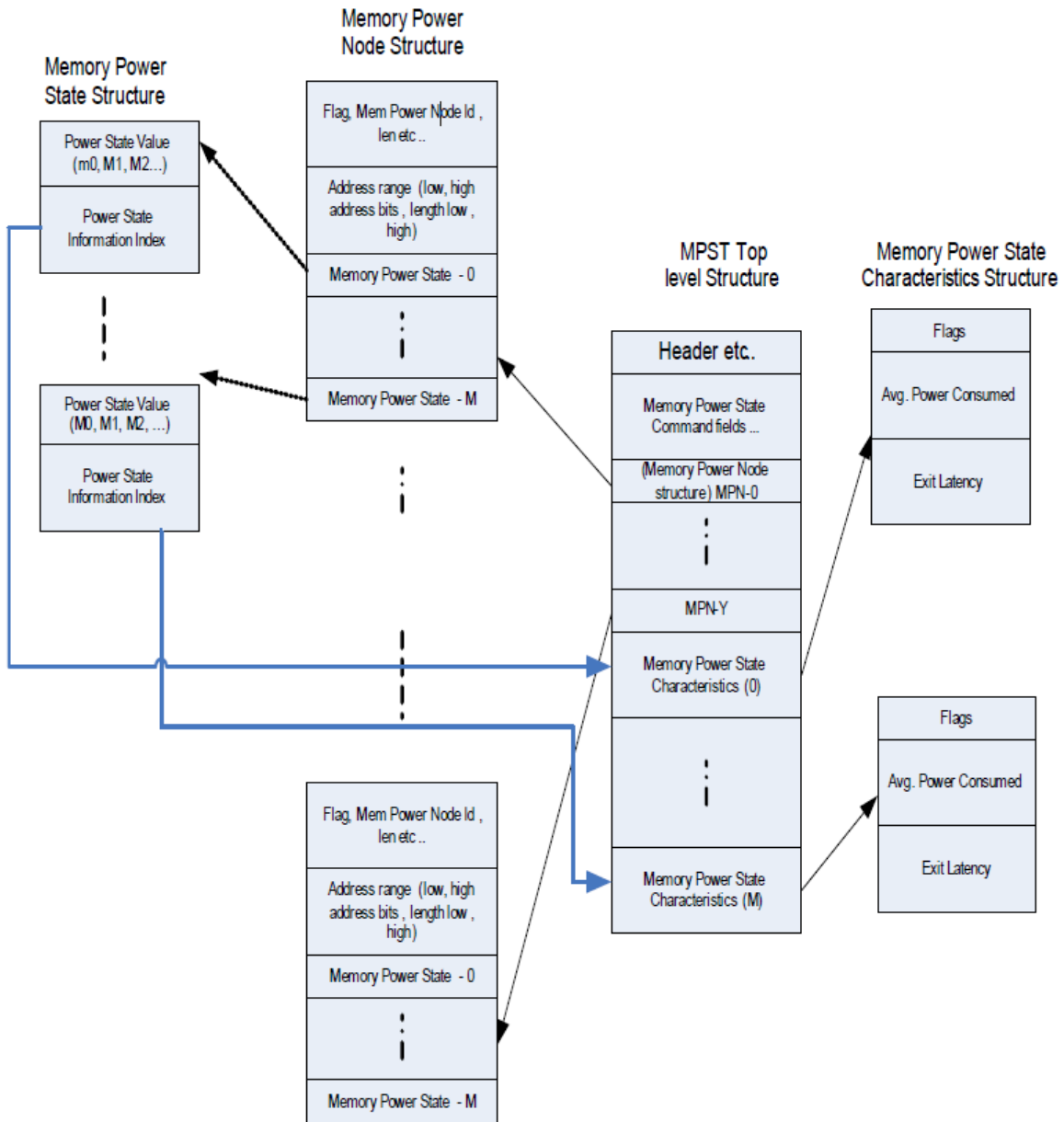

Fig. 5.5: MPST ACPI Table Overview

Table 5.89: MPST Table Structure

Field	Byte Length	Byte Offset	Description
Header			
- Signature	4	0	'MPST'. Signature for Memory Power State Table
- Length	4	4	Length in bytes for entire MPST. The length implies the number of Entry fields at the end of the table
- Revision	1	8	1
- Checksum	1	9	Entire table must sum to zero
- OEMID	6	10	OEM ID
- OEM Table ID	8	16	For the memory power state table, the table ID is the manufacturer model ID
- OEM Revision	4	24	OEM revision of memory power state Table for supplied OEM Table ID
- Creator ID	4	28	Vendor ID of utility that created the table
- Creator Revision	4	32	Revision of utility that created the table
Memory PCC			
- MPST Platform Communication Channel Identifier	1	36	Identifier of the MPST Platform Communication Channel.
- <i>Reserved</i>	3	37	Reserved
Memory Power Node			
- Memory Power Node Count	2	40	Number of Memory power Node structure entries
- <i>Reserved</i>	2	42	Reserved
- Memory Power Node Structure [Memory Power Node Count]	—	—	This field provides information on the memory power nodes present in the system. The information includes memory node id, power states supported & associated latencies. Further details of this field are specified in Memory Power Node.
Memory Power State Characteristics			
- Memory Power State Characteristics Count	2	—	Number of Memory power State Characteristics Structure entries
- <i>Reserved</i>	2	—	Reserved
- Memory Power State Characteristics Structure [m]	—	—	This field provides information of memory power states supported in the system. The information includes power consumed, transition latencies, relevant flags.

5.2.22.1 MPST PCC Sub Channel

The MPST PCC Sub Channel Identifier value provided by the platform in this field should be programmed to the Type field of PCC Communications Subspace Structure. The MPST table references its PCC Subspace in a given platform by this identifier, as shown in [Table 5.89](#).

5.2.22.1.1 Using PCC registers

OSPM will write PCC registers by filling in the register value in PCC sub channel space and issuing a PCC Execute command. See the table below. All other command values are reserved.

Table 5.90: PCC Command Codes used by MPST Platform Communication Channel

Command	Description
0x00-0x02	All other values are reserved.
0x03	Execute MPST Command.
0x04-0xFF	All other values are reserved.

Table 5.91: MPST Platform Communication Channel Shared Memory Region

Field	Byte Length	Byte Offset	Description
Signature	4	0	The PCC signature. The signature of a subspace is computed by a bitwise-or of the value 0x50434300 with the subspace ID. For example, subspace 3 has signature 0x50434303.
Command	2	4	PCC command field: see Section 14
Status	2	6	PCC status field: see Section 14
Communication Space			
MEMORY_POWER_COMMAND_REGISTER	4	8	Memory region for OSPM to write the requested memory power state. Write: 1 to this field to GET the memory_↵ ↵power state 2 to this field to set the memory_↵ ↵power state 3 - GET AVERAGE POWER CONSUMED 4 - GET MEMORY ENERGY CONSUMED

continues on next page

Table 5.91 – continued from previous page

Field	Byte Length	Byte Offset	Description
MEMORY_POWER_STATUS_REGISTER	4	12	<p>Bits [3:0]: Status (specific to MEMORY_POWER_COMMAND_REGISTER):</p> <ul style="list-style-type: none"> - 0000b = Success - 0001b = Not Valid - 0010b = Not Supported - 0011b = Busy - 0100b = Failed - 0101b = Aborted - 0110b = Invalid Data - Other values reserved <p>Bit [4]: Background Activity specific to the following MEMORY_POWER_COMMAND_REGISTER value:</p> <ul style="list-style-type: none"> 3 - GET AVERAGE POWER CONSUMED 4 - GET MEMORY ENERGY CONSUMED <p>0b = inactive 1b = background memory activity is ↪ in progress</p> <p>Bits [31:5]: Reserved</p>
POWER_STATE_ID	4	16	On completion of a GET operation, OSPM reads the current platform state ID from this field. Prior to a SET operation, OSPM populates this field with the power state value which needs to be triggered. Power State values will be based on the platform capability.
MEMORY_POWER_NODE_ID	4	20	This field identifies Memory power node number for the command.
MEMORY_ENERGY_CONSUMED	8	24	This field returns the energy consumed by the memory that constitutes the MEMORY_POWER_NODE_ID specified in the previous field. A value of all 1s in this field indicates that platform does not implement this field.
EXPECTED_AVERAGE_POWER_CONSUMED	8	32	This field returns the expected average power consumption for the memory constituted by MEMORY_POWER_NODE_ID. A value of all 1s in this field indicates that platform does not implement this field.

Note: OSPM should use the ratio of computed memory power consumed to expected average power consumed in determining the memory power management action.

5.2.22.2 Memory Power State

Memory Power State represents the state of a memory power node (which maps to a memory address range) while the platform is in the G0 working state. Memory power node could be in active state named MPS0 or in one of the power manage states MPS1-MPSn.

It should be noted that active memory power state (MPS0) does not preclude memory power management in that state. It only indicates that any active state memory power management in MPS0 is transparent to the OSPM and more importantly does not require assist from OSPM in terms of restricting memory occupancy and activity.

MPS1-MPSn states are characterized by non-zero exit latency for exit from the state to MPS0. These states could require explicit OSPM-initiated entry and exit, explicit OSPM-initiated entry but autonomous exit or autonomous entry and exit. In all three cases, these states require explicit OSPM action to isolate and free the memory address range for the corresponding memory power node.

Transitions to more aggressive memory power states (for example, from MPS1 to MPS2) can be entered on progressive idling but require transition through MPS0 (i.e. $MPS1 \rightarrow MPS0 \rightarrow MPS2$). Power state transition diagram is shown in Fig. 5.6 .

It is possible that after OSPM request a memory power state, a brief period of activity returns the memory power node to MPS0 state . If platform is capable of returning to a memory power state on subsequent period of idle, the platform must treat the previously requested memory power state as a persistent hint.

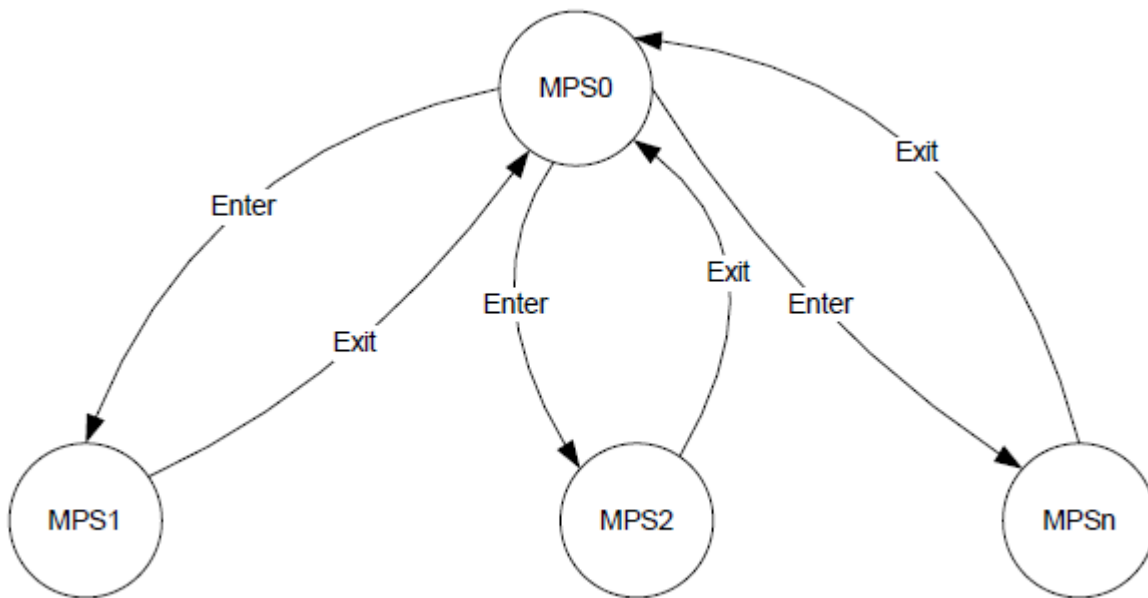

Fig. 5.6: Memory Power State Transitions

The following table enumerates the power state values that a node can transition to.

Table 5.92: Power State Values

Value	State Name	Description
0	MPS0	This state value maps to active state of memory node (Normal operation). OSPM can access memory during this state.
1	MPS1	This state value can be mapped to any memory power state depending on the platform capability. The platform will inform the features of MPS1 state using the Memory Power State Structure. By convention, it is required that low value power state will have lower power savings and lower latencies than the higher valued power states.
2,3...n	MPS2, MPS3, ... MPSn	Same description as MPS1.

The following table provides the list of command status options:

Table 5.93: Command Status

Field	Bit Length	Bit Off-set	Description
Command Complete	1	0	If set, the platform has completed processing the last command.
SCI Doorbell	1	1	If set, then this PCC Sub-Channel has signaled the SCI door bell. In Response to this SCI, OSPM should probe the Command Complete and the Platform Notification fields to determine the cause of SCI.
Error	1	2	If set, an error occurred executing the last command.
Platform Notification	1	3	Indicates that the SCI doorbell was invoked by the platform.
<i>Reserved</i>	12	4	Reserved.

5.2.22.3 Action Sequence

SetMemoryPowerState: The following sequence needs to be done to set a memory power state.

1. Write target POWER NODE ID value to MEMORY_POWER_NODE_ID register of PCC sub channel.
StepNumList-1 Write target POWER NODE ID value to MEMORY_POWER_NODE_ID register of PCC sub channel.
2. Write desired POWER STATE ID value to POWER STATE ID register of PCC sub channel.
3. Write SET (See Table 5.91) to MEMORY_POWER_STATE register of PCC sub channel.
4. Write PCC EXECUTE (See PCC Command Codes used by MPST Platform Communication Channel)
5. OSPM rings the door bell by writing to Doorbell register.
6. Platform completes the request and will generate SCI to indicate that the command is complete.
7. OSPM reads the Status register for the PCC sub channel and confirms that the command was successfully completed.

GetMemoryPowerState: The following sequence needs to be done to get the current memory power state.

1. Write target POWER NODE ID value to MEMORY_POWER_NODE_ID register of PCC sub channel.
StepNumList-1 Write target POWER NODE ID value to MEMORY_POWER_NODE_ID register of PCC sub channel.
2. Write GET (See Table 5.91) to MEMORY_POWER_STATE register of PCC sub channel.
3. Write PCC EXECUTE (See PCC Command Codes used by MPST Platform Communication Channel)

4. OSPM rings the door bell by writing to Doorbell register.
5. Platform completes the request and will generate SCI to indicate that command is complete.
6. OSPM reads Status register for the PCC sub channel and confirms that the command was successfully completed.
7. OSPM reads POWER STATE from POWER_STATE_ID register of PCC sub channel.

5.2.22.4 Memory Power Node

Memory Power Node is a representation of a logical memory region that needs to be transitioned in and out of a memory power state as a unit. This logical memory region is made up of one more system memory address range(s). A Memory Power Node is uniquely identified by Memory Power Node ID.

Note that memory power node structure defined in Table 5.94 can only represent a single address range. This address range should be 4K aligned. If a Memory Power Node contains more than one memory address range (i.e. non-contiguous range), firmware must construct a Memory power Node structure for each of the memory address ranges but specify the same Memory Power Node ID in all the structures.

Memory Power Nodes are not hierarchical. However, a given memory address range covered by a Memory power node could be fully covered by another memory power node if that nodes memory address range is inclusive of the other node’s range. For example, memory power node MPN0 may cover memory address range 1G-2G and memory power node MPN1 covers 1-4G. Here MPN1 memory address range also comprehends the range covered by MPN0.

OSPM is expected to identify the memory power node(s) that corresponds to the maximum memory address range that OSPM is able to power manage at a given time. For example, if MPN0 covers 1G-2G and MPN1 covers 1-4G and OSPM is able to power manage 1-4G, it should select MPN1. If MPN0 is in a non-active memory power state, OSPM must move MPN0 to MPS0 (Active state) before placing MPN1 in desired Memory Power State. Further, MPN1 can support more power states than MPN0. If MPN1 is in such a state, say MPS3, that MPN0 does not support, software must not query MPN0. If queried, MPN0 will return “not Valid” until MPN1 returns to MPS0.

- [Implementation Note] In general, memory nodes corresponding to larger address space ranges correspond to higher memory aggregation (e.g. memory covered by a DIMM vs. memory covered by a memory channel) and hence typically present higher power saving opportunities.

5.2.22.4.1 Memory Power Node Structure

The following structure specifies the fields used for communicating memory power node information. Each entry in the MPST table will be having corresponding memory power node structure defined.

This structure communicates address range, number of power states implemented, information about individual power states, number of distinct physical components that comprise this memory power node.

The physical component identifiers can be cross-referenced against the memory topology table entries.

Table 5.94: Memory Power Node Structure definition

Field	Byte Length	Byte Offset	Description
Flag	1	0	The flag describes type of memory node. See the Table 5.95 table below for details.
<i>Reserved</i>	1	1	For future use

continues on next page

Table 5.94 – continued from previous page

Field	Byte Length	Byte Offset	Description
Memory Power Node Id	2	2	This field provides memory power node number. This is a unique identification for Memory Power State Command and creation of freelists/cache lists in OSPM memory manager to bias allocation of non power managed nodes vs. power managed nodes.
Length	4	4	Length in bytes for Memory Power Node Structure. The length implies the number of Entry fields at the end of the table.
Base Address Low	4	8	Low 32 bits of Base Address of the memory range.
Base Address High	4	12	High 32 bits of Base Address of the memory range.
Length Low	4	16	Low 32 bits of Length of the memory range. This field along with “Length High” field is used to derive the end physical address of this address range.
Length High	4	20	High 32 bits of Length of the memory range.
Number of Power States (n)	4	24	This field indicates number of power states supported for this memory power node and in turn determines the number of entries in memory power state structure.
Number of Physical Components	4	28	This field indicates the number of distinct Physical Components that constitute this memory power node. This field is also used to identify the number of entries of Physical Component Identifier entries present at end of this table.
Memory Power State Structure [n]	—	32	This field provides information of various power states supported in the system for a given memory power node
Physical Component Identifier1	2	—	2 byte identifier of distinct physical component that makes up this memory power node
...	
Physical Component Identifier m	2	—	2 byte identifier of distinct physical component that makes up this memory power node

Table 5.95: Flag format

Bit	Name	Description
0	Enabled	If clear, the OSPM ignores this Memory Power Node Structure. This allows system firmware to populate the MPST with a static number of structures but enable them as necessary.
1	Power Managed Flag	1 - Memory node is power managed 0 - Memory node is not power managed. For non power managed node, OSPM shall not attempt to transition node into low power state. System behavior is undefined if OSPM attempts this. NOTE: If the memory range corresponding to the memory node includes platform firmware reserved memory that cannot be power managed, the platform should indicate such memory as “not power managed” to OSPM. This allows OSPM to ignore such ranges from its power optimization.
2	Hot Pluggable	This flag indicates that the memory node supports the hot plug feature. See <i>Interaction with Memory Hot Plug</i> for details.
3-7	Reserved	Reserved for future use

5.2.22.5 Memory Power State Structure

Table 5.96: Memory Power State Structure definition

Field	Byte Length	Byte Offset	Description
Power State Value	1	0	This field provides value of power state. The specific value to be used is system dependent. However convention needs to be maintained where higher numbers indicates deeper power states with higher power savings and higher latencies. For example, a power state value of 2 will have higher power savings and higher latencies than a power state value of 1.
Power State Information Index	1	1	This field provides unique index into the memory power state characteristics entries which will provide details about the power consumed, power state characteristics and transition latencies. The indexing mechanism is to avoid duplication (and hence reduce potential for mismatch errors) of memory power state characteristics entries across multiple memory nodes.

5.2.22.6 Memory Power State Characteristics structure

The table below describes the power consumed, exit latency and the characteristics of the memory power state. This table is referenced by a memory power node.

Table 5.97: Memory Power State Characteristics Structure

Field	Byte Length	Byte Offset	Description
Power State Structure ID	1	0	Bit [5:0] = This field describes the format of table Structure Power State Structure ID Value = 1 Bit [7:6] = Structure Revision Current revision is 1
Flag	1	1	The flag describes the caveats associated with entering the specified power state. Refer to Table 5.98 for details.
<i>Reserved</i>	2	2	Reserved
Average Power Consumed in MPS0 state (in milli watts)	4	4	This field provides average power consumed for this memory power node in MPS0 state. This power is measured in milli-Watts and signifies the total power consumed by this memory the given power state as measured in DC watts. Note that this value should be used as guideline only for estimating power savings and not as actual power consumed. Also memory power node can map to single or collection of RANKs/DIMMs. The actual power consumed is dependent on DIMM type, configuration and memory load.
Relative Power Saving to MPS0 state	4	8	This is a percentage of power saved in MPSx state relative to MPS0 state and should be calculated as $\frac{\text{MPS0 power} - \text{MPSx power}}{\text{MPS0 Power}} * 100$. When this entry is describing MPS0 state itself, OSPM should ignore this field.
Exit Latency (in ns) (MPSx -> MPS0)	8	12	This field provides latency of exiting out of a power state (MPSx) to active state (MPS0). The unit of this field is nanoseconds. When this entry is describing MPS0 state itself, OSPM should ignore this field.

continues on next page

Table 5.97 – continued from previous page

Field	Byte Length		Byte Offset
<i>Reserved</i>	8	20	Reserved for future use.

Table 5.98: **Flag format of Memory Power State Characteristics Structure**

Bit	Name	Description
0	Memory Content Preserved	If Bit [0] is set, it indicates memory contents will be preserved in the specified power state. If Bit [0] is clear, it indicates memory contents will be lost in the specified power state (e.g. for states such as offline).
1	Autonomous Memory Power State Entry	If Bit [1] is set, this field indicates that given memory power state entry transition needs to be triggered explicitly by OSPM by calling the Set Power State command. If Bit [1] is clear, this field indicates that given memory power state entry transition is automatically implemented in hardware and does not require a OSPM trigger. The role of OSPM in this case is to ensure that the corresponding memory region is idled from a software standpoint to facilitate entry to the state. Not meaningful for MPS0 - write it for this table.
2	Autonomous Memory Power State Exit	If Bit [1] is set, this field indicates that given memory power state exit needs to be explicitly triggered by the OSPM before the memory can be accessed. System behavior is undefined if OSPM or other software agents attempt to access memory that is currently in a low power state. If Bit [1] is clear, this field indicates that given memory power state is exited automatically on access to the memory address range corresponding to the memory power node.
3-7	<i>Reserved</i>	Reserved for future use.

5.2.22.6.1 Power Consumed

Average Power Consumed in MPS0 state indicates the power in milli Watts for the MPS0 state. Relative power savings to MPS0 indicates the savings in the MPSx state as a percentage of savings relative to MPS0 state.

5.2.22.6.2 Exit Latency

Exit Latency provided in the Memory Power Characteristics structure for a specific power state is inclusive of the entry latency for that state.

Exit latency must always be provided for a memory power state regardless of whether the memory power state entry and/or exit are autonomous or requires explicit trigger from OSPM.

5.2.22.7 Autonomous Memory Power Management

Not all memory power management states require OSPM to actively transition a memory power node in and out of the memory power state. Platforms may implement memory power states that are fully handled in hardware in terms of entry and exit transition. In such fully autonomous states, the decision to enter the state is made by hardware based on the utilization of the corresponding memory region and the decision to exit the memory power state is initiated in response to a memory access targeted to the corresponding memory region.

The role of OSPM software in handling such autonomous memory power states is to vacate the use of such memory regions when possible in order to allow hardware to effectively save power. No other OSPM initiated action is required for supporting these autonomously power managed regions. However, it is not an error for OSPM explicitly initiates

a state transition to an autonomous entry memory power state through the MPST command interface. The platform may accept the command and enter the state immediately in which case it must return command completion with SUCCESS (00000b) status. If platform does not support explicit entry, it must return command completion with NOT SUPPORTED (00010b) status.

5.2.22.8 Handling BIOS Reserved Memory

Platform firmware may have regions of memory reserved for its own use that are unavailable to OSPM for allocation. Memory nodes where all (or a portion) of the memory is reserved by platform firmware may pose a problem for OSPM because it does not know whether the platform firmware reserved memory is in use.

If the platform firmware reserved memory impacts the ability of the memory power node to enter memory power state(s), the platform must indicate to OSPM (by clearing the Power Managed Flag - see [Table 5.95](#) for details) that this memory power node cannot be power managed. This allows OSPM to ignore such ranges from its memory power optimization.

5.2.22.9 Interaction with NUMA processor and memory affinity tables

The memory power state table describes address range for each of the memory power nodes specified. OSPM can use the address ranges information provided in MPST table and derive processor affinity of a given memory power node based on the SRAT entries created by the platform boot firmware. The association of memory power node to proximity domain can be used by OSPM to implement memory coalescing taking into account NUMA node topology for memory allocation/release and manipulation of different page lists in memory management code (implementation specific).

An example of policy which can be implemented in OSPM for memory coalescing is: OSPM can prefer allocating memory from local memory power nodes before going to remote memory power nodes. The later sections provide sample NUMA configurations and explain the policy for various memory power nodes.

5.2.22.10 Interaction with Memory Hot Plug

The hot pluggable memory regions are described using memory device objects (see [Section 9.11](#)). The memory address ranges of these memory device objects are defined using the `_CRS` method.

```
Scope (\_SB) {
  Device (MEM0) {
    Name (_HID, EISAID ("PNP0C80"))
    Name (_CRS, ResourceTemplate () {
      QwordMemory (
        ResourceConsumer,
        ,
        MinFixed,
        MaxFixed,
        Cacheable,
        ReadWrite,
        0xFFFFFFFF,
        0x10000000,
        0x30000000,
        0, , ,
      )
    })
  }
}
```

The memory power state table (MPST) is a static structure created for all memory objects independent of hot plug status (online or offline) during initialization. The OSPM will populate the MPST table during the boot. If hot-pluggable flag is set for a given memory power node in MPST table, OSPM will not use this node till physical presence of memory is communicated through ACPI notification mechanism.

The association between memory device object (e.g. MEM0) to the appropriate memory power node id in the MPST table is determined by comparing the address range specified using _CRS method and address ranges configured in the MPST table entries. This association needs to be identified by OSPM as part of ACPI memory hot plug implementation. When memory device is hot added, as part of existing acpi driver for memory hot plug, OSPM will scan device object for _CRS method and get the relevant address ranges for the given memory object, OSPM will determine the appropriate memory power node ids based on the address ranges from _CRS and enable it for power management and memory coalescing.

Similarly when memory is hot removed, the corresponding memory power nodes will be disabled.

5.2.22.11 OS Memory Allocation Considerations

OSes (non-virtualized OS or a hypervisor/VMM) may need to allocate non-migratable memory. It is recommended that the OSes (if possible) allocate this memory from memory ranges corresponding to memory power nodes that indicate they are not power manageable. This allows OS to optimize the power manageable memory power nodes for optimal power savings.

OSes can assume that memory ranges that belong to memory power nodes that are power manageable (as indicated by the flag) are interleaved in a manner that does no impact the ability of that range to enter power managed states. For example, such memory is not cacheline interleaved.

Reference to memory in this document always refers to host physical memory. For virtualized environments, this requires hypervisors to be responsible for memory power management. Hypervisors also have the ability to create opportunities for memory power management by vacating appropriate host physical memory through remapping guest physical memory.

OSes can assume that the memory ranges included in MPST always refer to memory store - either volatile or non-volatile and never to MMIO or MMCFG ranges.

5.2.22.12 Platform Memory Topology Table (PMTT)

This table describes the memory topology of the system to OSPM, where the memory topology can be logical or physical. The topology is provided as a hierarchy of memory devices where the top level memory devices (e.g. sockets) are associated with the platform, down to the last level physical components (e.g. DIMMs) associated with a parent memory device.

Table 5.99: Platform Memory Topology Table

Field	Byte Length	Byte Offset	Description
Header			
- Signature	4	0	'PMTT'. Signature for Platform Memory Topology Table.
- Length	4	4	Length in bytes of the entire PMTT.

continues on next page

Table 5.99 – continued from previous page

Field	Byte Length	Byte Offset	Description
- Revision	1	8	Revision number of the <i>Platform Memory Topology Table</i> , <i>Common Memory Device</i> , and memory device structures (Table 5.101, Table 5.102, Table 5.103, and Table 5.104) defined in this specification. Current value: 2 Compatibility Note: Revision 1 is deprecated in ACPI Specification 6.4.
- Checksum	1	9	Entire table must sum to zero.
- OEMID	6	10	OEM ID
- OEM Table ID	8	16	For the PMTT, the table ID is the manufacturer model ID
- OEM Revision	4	24	OEM revision of the PMTT for supplied OEM Table ID.
- Creator ID	4	28	Vendor ID of utility that created the table.
- Creator Revision	4	32	Revision of utility that created the table.
Number of Memory Devices	4	36	The number of top level Memory Device structures that immediately follow. A zero in this field indicates no Memory Device structures follow.
Memory Device Structure [n]	—	40	A list of memory device structures for the platform. See Table 5.100 below.

Table 5.100: Common Memory Device

Field	Byte Length	Byte Offset	Description
Header			
- Type	1	0	This field describes the type of Memory Device: 0 - Socket 1 - Memory Controller 2 - DIMM 3 - 0xFE - <i>Reserved</i> , 0xFF - Vendor Specific Type
- <i>Reserved</i>	1	1	Reserved, must be zero.
- Length	2	2	Length in bytes for this structure. The length includes the Type Specific Data, but not memory devices associated with this device.

continues on next page

Table 5.100 – continued from previous page

Field	Byte Length	Byte Offset	Description
- Flags	2	4	<p>Bit [0]:</p> <p>0 - Indicates that this is not a top level device.</p> <p>1 - Indicates that this is a top level aggregator device. This device must be counted in the number of top level aggregator devices in PMTT table and must be surfaces via PMTT.</p> <p>Bit [1]:</p> <p>0 indicates a logical element of topology.</p> <p>1 indicates a physical element of the topology.</p> <p>Bits [2] and [3]:</p> <p>01 - Indicates that components aggregated by this device implement both volatile and non-volatile memory</p> <p>10 - Indicates that all components aggregated by this device implement non-volatile memory</p> <p>11 - Reserved</p> <p>Bits [15:4] Reserved, must be zero</p>
<i>Reserved</i>	2	6	Reserved, must be zero.
Number of Memory Devices	4	8	The number of Memory Devices associated with this device. A zero in this field indicates that no Memory Device structures follow the Type Specific Data.
Type Specific Data	—	12	Type specific data. Interpretation of this data is specific to the type of the memory device. See Table 5.101 , Table 5.102 , Table 5.103 , and Table 5.104 .
Memory Device Structure [n]	—	—	An optional list of Memory Device structures associated with this device.

Table 5.101: Socket Type Data

Field	Byte Length	Byte Offset	Description
Common Memory Device Header	12	0	See Table 5.100 . Type = 0 - Socket. Length =16.
Socket Identifier	2	12	Uniquely identifies the socket in the system.
<i>Reserved</i>	2	14	Reserved, must be zero.
Memory Device Structure [n]	—	16	An optional list of Memory Device structures associated with this socket.

Table 5.102: Memory Controller Type Data

Field	Byte Length	Byte Offset	Description
Common Memory Device Header	12	0	See Table 5.100 . Type = 1 - Memory Controller. Length =16.
Memory Controller Identifier	2	12	Uniquely identifies the memory controller within its parent memory device type.
<i>Reserved</i>	2	14	Reserved, must be zero.

continues on next page

Table 5.102 – continued from previous page

Field	Byte Length	Byte Offset	Description
Memory Device Structure [n]	—	16	An optional list of Memory Device structures associated with this memory controller.

Table 5.103: DIMM Type Specific Data

Field	Byte Length	Byte Offset	Description
Common Memory Device Header	12	0	See Table 5.100. Type = 2 - DIMM. Length =16.
SMBIOS Handle	4	12	Refers to Type 17 table handle of corresponding SMBIOS record. The platform indicates that this field is not valid by setting a value of 0xFFFFFFFF. If the platform provides a valid handle, the upper 2 bytes must be 0 (since SMBIOS handles are 2 bytes only). NOTE: The use of this handle is for management software to be able to cross-reference the physical DIMM described in SMBIOS against the topology described in this table. It is not expected that OSPM will utilize this field.

Table 5.104: Vendor Specific Type Data

Field	Byte Length	Byte Offset	Description
Common Memory Device Header	12	0	See Table 5.100. Type = 0xFF - Vendor Specific.
Type UUID	16	12	Vendor specific type unique identifier.
Vendor Specific Data	—	28	Vendor specific type data.
Memory Device Structure [n]	—	—	An optional list of Memory Device structures associated with this device.

5.2.23 Boot Graphics Resource Table (BGRT)

The Boot Graphics Resource Table (BGRT) is an optional table that provides a mechanism to indicate that an image was drawn on the screen during boot, and some information about the image.

The table is written when the image is drawn on the screen. This should be done after it is expected that any firmware components that may write to the screen are done doing so and it is known that the image is the only thing on the screen. If the boot path is interrupted (e.g., by a key press), the Displayed bit within the status field should be changed to 0 to indicate to the OS that the current image is invalidated.

This table is only supported on UEFI systems.

Table 5.105: Boot Graphics Resource Table Fields

Field	Byte Length	Byte Offset	Description
Header			
- Signature	4	0	“BGRT” Signature for the table.

continues on next page

Table 5.105 – continued from previous page

- Length	4	4	Length, in bytes, of the entire table
- Revision	1	8	1
- Checksum	1	9	Entire table must sum to zero.
- OEMID	6	10	OEM ID
- OEM Table ID	8	16	The table ID is the manufacturer model ID.
- OEM Revision	4	24	OEM revision for supplied OEM Table ID.
- Creator ID	4	28	Vendor ID of utility that created the table.
- Creator Revision	4	32	Revision of utility that created the table.
Version	2	36	2-bytes (16 bit) version ID. This value must be 1.
Status [n]	1	38	1-byte status field indicating current status of the image: Bits [7:3] = Reserved (must be zero) Bits [2:1] = Orientation Offset. These bits describe the clockwise degree offset from the image's default orientation. [00] = 0, no offset [01] = 90 [10] = 180 [11] = 270 Bit [0] = Displayed. A one indicates the boot image graphic is displayed.
Image Type	1	39	1-byte enumerated type field indicating format of the image: 0 = Bitmap 1 - 255 Reserved (for future use)
Image Address	8	40	8-byte (64 bit) physical address pointing to the firmware's in-memory copy of the image bitmap.
Image Offset X	4	48	A 4-byte (32-bit) unsigned long describing the display X-offset of the boot image. (X, Y) display offset of the top left corner of the boot image. The top left corner of the display is at offset (0, 0).
Image Offset Y	4	52	A 4-byte (32-bit) unsigned long describing the display Y-offset of the boot image. (X, Y) display offset of the top left corner of the boot image. The top left corner of the display is at offset (0, 0).

The BGRT is a dynamic ACPI table that enables boot firmware to provide OPSM with a pointer to the location in memory where the boot graphics image is stored.

5.2.23.1 Version

The version field identifies which revision of the BGRT table is implemented. The version field should be set to 1.

5.2.23.2 Status

The status field contains information about the current status of the BGRT image (see Table 5.105 above).

5.2.23.3 Image Type

The Image type field contains information about the format of the image being returned. If the value is 0, the Image Type is Bitmap. The format for a Bitmap is defined at the reference located in “Links to ACPI-Related Documents” (<http://uefi.org/acpi>) under the heading “Types of Bitmaps”.

All other values not defined in the table are reserved for future use.

5.2.23.4 Image Address

The Image Address contains the location in memory where an in-memory copy of the boot image can be found. The image should be stored in `EfiBootServicesData`, allowing the system to reclaim the memory when the image is no longer needed.

Implementations must present the image in a 24-bit bitmap with pixel format `0xRRGGBB`, or a 32-bit bitmap with the pixel format `0xrrRRGGBB`, where ‘rr’ is reserved.

5.2.23.5 Image Offset

The Image Offset contains 2 consecutive 4-byte unsigned longs describing the (X, Y) display offset of the top-left corner of the boot image. The top-left corner of the display is at offset (0, 0).

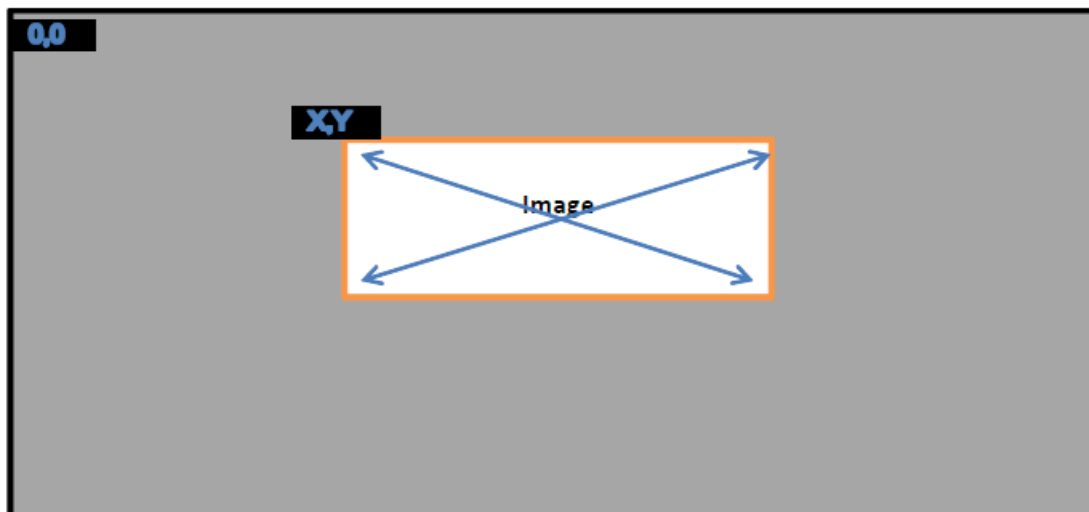

Fig. 5.7: Image Offset

5.2.24 Firmware Performance Data Table (FPDT)

This section describes the format of the Firmware Performance Data Table (FPDT), which provides sufficient information to describe the platform initialization performance records. This information represents the boot performance data relating to specific tasks within the firmware boot process. The FPDT includes only those mileposts that are part of every platform boot process:

- End of reset sequence (Timer value noted at beginning of platform boot firmware initialization - typically at reset vector)
- Handoff to OS Loader

This information represents the firmware boot performance data set that would be used to track performance of each UEFI phase, and would be useful for tracking impacts resulting from changes due to hardware/software configuration.

All timer values are express in 1 nanosecond increments. For example, if a record indicates an event occurred at a timer value of 25678, this means that 25.678 microseconds have elapsed from the last reset of the timer measurement. All timer values will be required to have an accuracy of +/- 10%.

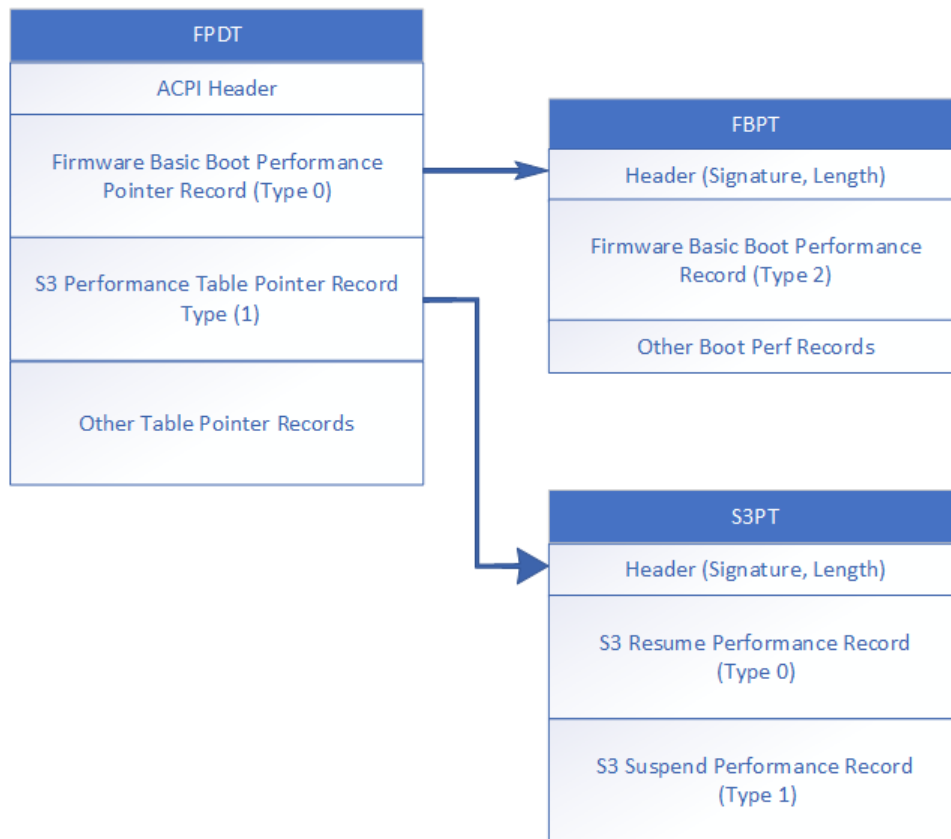

Fig. 5.8: FPDT Hierarchy Structure

Table 5.106: Firmware Performance Data Table (FPDT) Format

Field	Byte Length	Byte Offset	Description
Header			
- Signature	4	0	'FPDT' Signature for the Firmware Performance Data Table.
- Length	4	4	The length of the table, in bytes, of the entire FPDT.

continues on next page

Table 5.106 – continued from previous page

Field	Byte Length	Byte Offset	Description
- Revision	1	8	The revision of the structure corresponding to the signature field for this table. For the Firmware Performance Data Table conforming to this revision of the specification, the revision is 1.
- Checksum	1	9	The entire table, including the checksum field, must add to zero to be considered valid.
- OEMID	6	10	An OEM-supplied string that identifies the OEM.
- OEM Table ID	8	16	An OEM-supplied string that the OEM uses to identify this particular data table.
- OEM Revision	4	24	An OEM-supplied revision number.
- Creator ID	4	28	The Vendor ID of the utility that created this table.
- Creator Revision	4	32	The revision of the utility that created this table.
Performance Records	–	36	A set of FPDT Performance Records, as defined in Table 5-112. Section 5.2.26.4

5.2.24.1 Performance Record Format

A performance record is comprised of a sub-header including a record type and length, and a set of data. The format of the data is specific to the record type. In this manner, records are only as large as needed to contain the specific type of data to be conveyed.

Note that unless otherwise specified, multiple records are permitted for a given type, because some events may occur multiple times during the boot process.

Table 5.107: Performance Record Structure

Field	Byte Length	Byte Offset	Description
Performance Record Type	2	0	This value depicts the format and contents of the performance record.
Record Length	1	2	This value depicts the length of the performance record, in bytes.
Revision	1	3	This value is updated if the format of the record type is extended. Any changes to a performance record layout must be backwards-compatible in that all previously defined fields must be maintained if still applicable, but newly defined fields allow the length of the performance record to be increased. Previously defined record fields must not be redefined, but are permitted to be deprecated.
Data	–	4	The content of this field is defined by the Performance Record Type definition.

5.2.24.2 FPDT Performance Record Types

The table below describes the various records contained within the FPDT, and their corresponding Record Types.

Table 5.108: FPDT Performance Record Types

Record Value	Type	Description
0x0000	Firmware Basic Boot Performance Pointer Record	Record containing a pointer to the Firmware Basic Boot Performance Table.
0x0001	S3 Performance Table Pointer Record	Record containing a pointer to the S3 Performance Table.
0x0002 - 0x0FFF	Reserved	Reserved for ACPI specification usage.
0x1000 - 0x1FFF	Reserved	Reserved for Platform Vendor usage.
0x2000 - 0x2FFF	Reserved	Reserved for Hardware Vendor usage.
0x3000 - 0x3FFF	Reserved	Reserved for platform firmware Vendor usage.
0x4000 - 0xFFFF	Reserved	Reserved for future use

5.2.24.3 Runtime Performance Record Types

The table below describes the various Runtime Performance records and their corresponding Record Types. These records are not contained within the FPDT; they are referenced by their respective pointer records in the FPDT.

Table 5.109: Runtime Performance Record Types

Record Type Value	Type	Description
0x0000	Basic S3 Resume Performance Record	Performance record describing minimal firmware performance metrics for S3 resume operations.
0x0001	Basic S3 Suspend Performance Record	Performance record describing minimal firmware performance metrics for S3 suspend operations.
0x0002	Firmware Basic Boot Performance Data Record	Performance record showing basic performance metrics for critical phases of the firmware boot process.
0x0003 - 0x0FFF	Reserved	Reserved for ACPI specification usage.
0x1000 - 0x1FFF	Reserved	Reserved for Platform Vendor usage.
0x2000 - 0x2FFF	Reserved	Reserved for Hardware Vendor usage.
0x3000 - 0x3FFF	Reserved	Reserved for platform firmware Vendor usage.
0x4000 - 0xFFFF	Reserved	Reserved for future use

5.2.24.4 Firmware Basic Boot Performance Table Pointer Record

The Firmware Basic Boot Performance Table Pointer Record contains a pointer to the Firmware Basic Boot Performance Table. The Firmware Basic Boot Performance Table itself exists in a range of memory described as ACPI AddressRangeReserved in the system memory map. The record pointer is a required entry in the FPDT for any system, and the pointer must point to a valid static physical address. Only one of these records will be produced.

Table 5.110: Firmware Basic Boot Performance Table Pointer Record

Field	Byte Length	Byte Offset	Description
Performance Record Type	2	0	0 - Firmware Basic Boot Performance Table Pointer Record

continues on next page

Table 5.110 – continued from previous page

Field	Byte Length	Byte Offset	Description
Record Length	1	2	16 - This value depicts the length of the performance record, in bytes.
Revision	1	3	1 - Revision of this Performance Record
<i>Reserved</i>	4	4	Reserved
FBPT Pointer	8	8	64-bit processor-relative physical address of the Firmware Basic Boot Performance Table

5.2.24.5 S3 Performance Table Pointer Record

The S3 Performance Table Pointer Record contains a pointer to the S3 Performance Table. The S3 Performance Table itself exists in a range of memory described as ACPI AddressRangeReserved in the system memory map. The record pointer is a required entry in the FPDT for any system supporting the S3 state, and the pointer must point to a valid static physical address. Only one of these records will be produced.

Table 5.111: S3 Performance Table Pointer Record

Field	Byte Length	Byte Offset	Description
Performance Record Type	2	0	1 - S3 Performance Table Pointer Record
Record Length	1	2	16 - This value depicts the length of the performance record, in bytes.
Revision	1	3	1 - Revision of this Performance Record
<i>Reserved</i>	4	4	Reserved
S3PT Pointer	8	8	64-bit processor-relative physical address of the S3 Performance Table

5.2.24.6 Firmware Basic Boot Performance Table

The Firmware Basic Boot Performance Table resides outside of the FPDT. It includes a header, defined in Table 5.112, and one or more Performance Records.

All event entries will be overwritten during the platform runtime firmware S4 resume sequence. The Firmware Basic Boot Performance Table must include the Firmware Basic Boot Performance Data Record. Other entries are optional.

Table 5.112: Firmware Basic Boot Performance Table Header

Field	Byte Length	Byte Offset	Description
Signature	4	0	'FBPT' is the signature to use.
Length	4	4	Length of the Firmware Basic Boot Performance Table. This includes the header and allocated size of the subsequent records. This size would at minimum include the size of the header and the Firmware Basic Boot Performance Data Record.

5.2.24.7 Firmware Basic Boot Performance Data Record

The Firmware Basic Boot Performance Data Record contains timer information associated with final OS loader activity, as well as data associated with boot time starting and ending information.

Table 5.113: Firmware Basic Boot Performance Data Record

Field	Byte Length	Byte Offset	Description
Performance Record Type	2	0	2 - Firmware Basic Boot Performance Data Record. Only one of these records will be produced.
Record Length	1	2	48 - This value depicts the length of the performance record, in bytes.
Revision	1	3	2 - Revision of this Performance Record
<i>Reserved</i>	4	4	Reserved
Reset End	8	8	Timer value logged at the beginning of firmware image execution. This may not always be zero or near zero.
OS Loader LoadImage Start	8	16	Timer value logged just prior to loading the OS boot loader into memory. For non-UEFI compatible boots, this field must be zero.
OS Loader StartImage Start	8	24	Timer value logged just prior to launching the currently loaded OS boot loader image. For non-UEFI compatible boots, the timer value logged will be just prior to the INT 19h handler invocation.
ExitBootServices Entry	8	32	Timer value logged at the point when the OS loader calls the ExitBootServices function for UEFI compatible firmware. For non-UEFI compatible boots, this field must be zero.
ExitBootServices Exit	8	40	Timer value logged at the point just prior to the OS loader gaining control back from the ExitBootServices function for UEFI compatible firmware. For non-UEFI compatible boots, this field must be zero.

5.2.24.8 S3 Performance Table

The S3 Performance Table resides outside of the FPDT. It includes a header, defined in [Table 5.115](#) , and one or more Performance Records.

All event entries must be initialized to zero during the initial boot sequence, and overwritten during the platform runtime firmware S3 resume sequence. The S3 Performance Table must include the Basic S3 Resume Performance Record. Other entries are optional.

Table 5.114: S3 Performance Table Header

Field	Byte Length	Byte Offset	Description
Signature	4	0	'S3PT' is the signature to use.
Length	4	4	Length of the S3 Performance Table. This includes the header and allocated size of the subsequent records. This size would at minimum include the size of the header and the Basic S3 Resume Performance Record.

Table 5.115: Basic S3 Resume Performance Record

Field	Byte Length	Byte Offset	Description
Runtime Performance Record Type	2	0	0 - The Basic S3 Resume Performance Record Type. Only one of these records will be produced.
Record Length	1	2	24 - The value depicts the length of this performance record, in bytes.
Revision	1	3	1 - Revision of this Performance Record
Resume Count	4	4	A count of the number of S3 resume cycles since the last full boot sequence.
FullResume	8	8	Timer recorded at the end of platform runtime firmware S3 resume, just prior to handoff to the OS waking vector. Only the most recent resume cycle's time is retained.
AverageResume	8	16	Average timer value of all resume cycles logged since the last full boot sequence, including the most recent resume. Note that the entire log of timer values does not need to be retained in order to calculate this average. $AverageResume_{new} = (AverageResume_{old} * (ResumeCount - 1) + FullResume) / ResumeCount$

Table 5.116: Basic S3 Suspend Performance Record

Field	Byte Length	Byte Offset	Description
Runtime Performance Record Type	2	0	1 - Basic S3 Suspend Performance Record. Zero to one of these records will be produced.
Record Length	1	2	20 - The value depicts the length of this performance record, in bytes.
Revision	1	3	1 - Revision of this Performance Record
SuspendStart	8	4	Timer value recorded at the OS write to SLP_TYP upon entry to S3. Only the most recent suspend cycle's timer value is retained.
SuspendEnd	8	12	Timer value recorded at the final firmware write to SLP_TYP (or other mechanism) used to trigger hardware entry to S3. Only the most recent suspend cycle's timer value is retained.

5.2.25 Generic Timer Description Table (GTDT)

This section describes the format of the Generic Timer Description Table (GTDT), which provides OSPM with information about a system's Generic Timers configuration. The Generic Timer (GT) is a standard timer interface implemented on ARM processor-based systems. The GT hardware specification can be found at *Links to ACPI-Related Documents* (<http://uefi.org/acpi>) under the heading *ARM Architecture*. The GTDT provides OSPM with information about a system's GT interrupt configurations, for both per-processor timers, and platform (memory-mapped) timers.

The GT specification defines the following per-processor timers:

- Secure EL1 timer
- Non-Secure EL1 timer
- EL2 timer
- Virtual EL1 timer
- Virtual EL2 timer

and defines the following memory-mapped Platform timers:

- GT Block
- Arm Generic Watchdog

Table 5.117: GTDT Table Structure

Field	Byte Length	Byte Offset	Description
Header			
- Signature	4	0	'GTDT'. Signature for the Generic Timer Description Table.
- Length	4	4	Length, in bytes, of the entire Generic Timer Description Table.
- Revision	1	8	3
- Checksum	1	9	Entire table must sum to zero.
- OEMID	6	10	OEM ID.
- OEM Table ID	8	16	The manufacturer model ID.
- OEM Revision	4	24	OEM revision for supplied OEM Table ID.
- Creator ID	4	28	Vendor ID of utility that created the table.
- Creator Revision	4	32	Revision of utility that created the table.
CntControlBase Physical Address	8	36	The 64-bit physical address at which the Counter Control block is located. This value is optional if the system implements EL3 (Security Extensions). If not provided, this field must be 0xFFFFFFFFFFFFFFFF.
Reserved	4	44	Must be zero
Secure EL1 Timer GSIV	4	48	GSIV for the secure EL1 timer. This value is optional, as an operating system executing in the non-secure world (EL2 or EL1), will ignore the content of these fields.
Secure EL1 Timer Flags	4	52	Flags for the secure EL1 timer (defined below). This value is optional, as an operating system executing in the non-secure world (EL2 or EL1) will ignore the content of this field.
Non-Secure EL1 Timer GSIV	4	56	GSIV for the non-secure EL1 timer.
Non-Secure EL1 Timer Flags	4	60	Flags for the non-secure EL1 timer (defined below).
Virtual EL1 Timer GSIV	4	64	GSIV for the virtual EL1 timer.
Virtual EL1 Timer Flags	4	68	Flags for the virtual EL1 timer (defined below)
EL2 Timer GSIV	4	72	GSIV for the EL2 timer.
EL2 Timer Flags	4	76	Flags for the EL2 timer(defined below).
CntReadBase Physical Address	8	80	The 64-bit physical address at which the Counter Read block is located. This value is optional if the system implements EL3 (Security Extensions). If not provided, this field must be 0xFFFFFFFFFFFFFFFF.
Platform Timer Count	4	88	Number of entries in the Platform Timer Structure[] array
Platform Timer Offset	4	92	Offset to the Platform Timer Structure[] array from the start of this table
Virtual EL2 Timer GSIV	4	96	GSIV for the virtual EL2 timer. This field is mandatory for systems implementing ARMv8.1 VHE. For systems not implementing ARMv8.1 VHE, this field is 0.

continues on next page

Table 5.117 – continued from previous page

Field	Byte Length	Byte Offset	Description
Virtual EL2 Timer Flags	4	100	Flags for the virtual EL2 timer (defined below). This field is mandatory for systems implementing ARMv8.1 VHE. For systems not implementing ARMv8.1 VHE, this field is 0.
Platform Timer Structure[]	—	Platform Timer Offset	Array of Platform Timer Type structures describing memory-mapped Timers available on this platform. These structures are described in the sections below.

The following flags each have the same definition, as shown in the table below: Secure EL1 Timer Flags, Non-Secure EL1 Timer Flags, EL2 Timer Flags, Virtual EL1 Timer Flags, and Virtual EL2 Timer Flags.

Table 5.118: Flag Definitions: Secure EL1 Timer, Non-Secure EL1 Timer, EL2 Timer, Virtual EL1 Timer and Virtual EL2 Timer

Bit Field	Bit Offset	Number of bits	Description
Timer interrupt Mode	0	1	This bit indicates the mode of the timer interrupt: 1: Interrupt is Edge triggered 0: Interrupt is Level triggered
Timer Interrupt polarity	1	1	This bit indicates the polarity of the timer interrupt: 1: Interrupt is Active low 0: Interrupt is Active high
Always-on Capability	2	1	This bit indicates the always-on capability of the timer implementation: 1: This timer is guaranteed to assert its interrupt and wake a processor, regardless of the processor’s power state. All of the methods by which an ARM Generic Timer may generate an interrupt must be supported, and must be capable of waking the processor. 0: This timer may lose context or may not be guaranteed to assert interrupts when its associated processor enters a low-power state.
<i>Reserved</i>	3	29	Reserved, must be zero.

The GTDT Platform Timer Structure [] field is an array of Platform Timer Type structures, each of which describes the configuration of an available platform timer. These timers are in addition to the per-processor timers described above them in the GTDT.

Table 5.119: Platform Timer Type Structures

Value	Description
0	GT Block
1	Arm Generic Watchdog

continues on next page

Table 5.119 – continued from previous page

Value	Description
0x02-0xFF	Reserved for future use

The first byte of each structure declares the type of that structure and the second and third bytes declare the length of that structure.

5.2.25.1 GT Block Structure

The GT Block is a standard timer block that is mapped into the system address space. Each GT Block implements up to 8 GTs (GT0 - GT7).

The format of the GT Block structure is shown in the following table.

Table 5.120: GT Block Structure Format

Field	Byte Length	Byte Offset	Description
Type	1	0	0x0 GT Block
Length	2	1	20+n*40, where n is the number of timers implemented in the GT Block
Reserved	1	3	Must be zero
GT Block Physical address (CntCtlBase)	8	4	The 64-bit physical address at which the GT CntCTL-Base Block is located
GT Block Timer Count	4	12	Number of Timers implemented in this GT Block ('n'). Must be less than or equal to 8.
GT Block Timer Offset	4	16	Offset to the Platform Timer Structure array from the start of this structure
GT Block Timer Structure[]	n*40	GT Block Timer Offset	Array of GT Block Timer Structures. See the GT Block Timer Structure Format table.

Table 5.121: GT Block Timer Structure Format

Field	Byte Length	Byte Offset	Description
GT Frame Number	1	0	The frame number (0-7) for this timer ('x')
Reserved	3	1	Must be zero
GTx Physical Address (CntBaseX)	8	4	Physical Address at which the CntBase block for GTx is located
GTx Physical Address (CntEL0BaseX)	8	12	Physical Address at which the CntEL0Base block for GTx is located. If this block is not implemented for GTx, must be 0xFFFFFFFFFFFFFFFF.
GTx Physical Timer GSIV	4	20	GSIV for the GTx physical timer
GTx Physical Timer Flags	4	24	Flags for the GTx physical timer. See Flag Definitions: GT Block Physical Timers and Virtual Timers.
GTx Virtual Timer GSIV	4	28	GSIV for the GTx virtual timer. If the Virtual Timer is not implemented for GTx, this field must be 0.
GTx Virtual Timer Flags	4	32	Flags for the GTx virtual timer, if implemented. See Flag Definitions: GT Block Physical Timers and Virtual Timers.

continues on next page

Table 5.121 – continued from previous page

Field	Byte Length	Byte Offset	Description
GTx Common Flags	4	36	See Common Flags.

Table 5.122: **Flag Definitions: GT Block Physical Timers and Virtual Timers**

Bit Field	Bit Off-set	Number of bits	Description
Timer interrupt Mode	0	1	This bit indicates the mode of the timer interrupt: 1: Interrupt is Edge triggered. 0: Interrupt is Level triggered.
Timer Interrupt polarity	1	1	This bit indicates the polarity of the timer interrupt: 1: Interrupt is Active low 0: Interrupt is Active high
Reserved	2	30	Reserved, must be zero.

Flag Definitions: Common Flags

Table 5.123: **Flag Definitions - Common Flags**

Bit Field	Bit Off-set	Number of bits	Description
Secure Timer	0	1	This bit indicates whether the timer is secure or non-secure: 1: Timer is Secure 0: Timer is Non-secure
Always-on Capability	1	1	This bit indicates the always-on capability of the Physical and Virtual Timers implementation: 1: This timer is guaranteed to assert its interrupt and wake a processor, regardless of the processor's power state. All of the methods by which an ARM Generic Timer may generate an interrupt must be supported, and must be capable of waking the processor. 0: This timer may lose context or may not be guaranteed to assert interrupts when its associated processor enters a low-power state.
Reserved	2	30	Reserved, must be zero.

5.2.25.2 Arm Generic Watchdog Structure

The Arm Generic Watchdog is a Platform GT with built-in support for use as the Watchdog timer on platforms compliant with the Server Base System Architecture (SBSA) or Base System Architecture (BSA). For more information, see [Links to ACPI-Related Documents](#) under the heading Arm Base System Architecture (BSA).

The format of the Arm Generic Watchdog structure is shown in the following table.

Table 5.124: Arm Generic Watchdog Structure Format

Field	Byte Length	Byte Offset	Description
Type	1	0	0x1 Watchdog GT
Length	2	1	28
Reserved	1	3	Must be zero
RefreshFrame Physical Address	8	4	Physical Address at which the RefreshFrame block is located
WatchdogControlFrame Physical Address	8	12	Physical Address at which the Watchdog Control Frame block is located
Watchdog Timer GSIV	4	20	GSIV for the Arm Generic Watchdog timer
Watchdog Timer Flags	4	24	Flags for the Arm Generic Watchdog timer. See Flag Definitions: Arm Generic Watchdog Timer.

Table 5.125: Flag Definitions - Arm Generic Watchdog Timer

Bit Field	Bit Offset	Number of bits	Description
Timer interrupt Mode	0	1	This bit indicates the mode of the timer interrupt: 1: Interrupt is Edge triggered 0: Interrupt is Level triggered
Timer Interrupt polarity	1	1	This bit indicates the polarity of the timer interrupt: 1: Interrupt is Active low 0: Interrupt is Active high
Secure Timer	2	1	This bit indicates whether the timer is secure or non-secure: 1: Timer is Secure 0: Timer is Non-secure
Reserved	3	29	Reserved, must be zero.

5.2.26 NVDIMM Firmware Interface Table (NFIT)

5.2.26.1 Overview

This optional table provides information that allows OSPM to enumerate NVDIMMs present in the platform and associate system physical address ranges created by the NVDIMMs. NVDIMMs are represented by zero or more NVDIMM devices under a single NVDIMM root device in ACPI namespace.

OSPM evaluates NFIT only during system initialization. Any changes to the NVDIMM state at runtime or information regarding hot added NVDIMMs are communicated using the `_FIT` method (See [Section 6.5.9](#)) of the NVDIMM root device.

The NFIT consists of the following structures:

1. System Physical Address (SPA) Range Structure(s) (see [Section 5.2.26.2](#)) – Describes the SPA ranges occupied by NVDIMMs and the types of the SPA ranges.
2. NVDIMM Region Mapping Structure(s) (see [Section 5.2.26.3](#)) – Describes mappings of NVDIMM regions to SPA ranges and NVDIMM region properties.
3. Interleave Structure(s) (see [Section 5.2.26.4](#)) – Describes the various interleave options used by NVDIMM regions.
4. SMBIOS Management Information Structure(s) (see [Section 5.2.26.5](#)) – Describes SMBIOS Table entries for hot added NVDIMMs.
5. NVDIMM Control Region Structure(s) (see [Section 5.2.26.6](#)) – Describes NVDIMM function interfaces, and if applicable, their Block Control Windows.
6. NVDIMM Block Data Window Region Structure(s) (see [Section 5.2.26.7](#)) – Describes Block Data Windows for a NVDIMM function interfaces that have Block Control Windows.
7. Flush Hint Address Structure(s) (see [Section 5.2.26.8](#)) – Describes special system physical addresses that when written help achieve durability for writes to NVDIMM regions.
8. Platform Capabilities Structure (see [Section 5.2.26.9](#)) – Describes the Platform Capabilities to inform OSPM of platform-wide NVDIMM capabilities.

The following figure illustrates the above structures and how they are associated with each other.

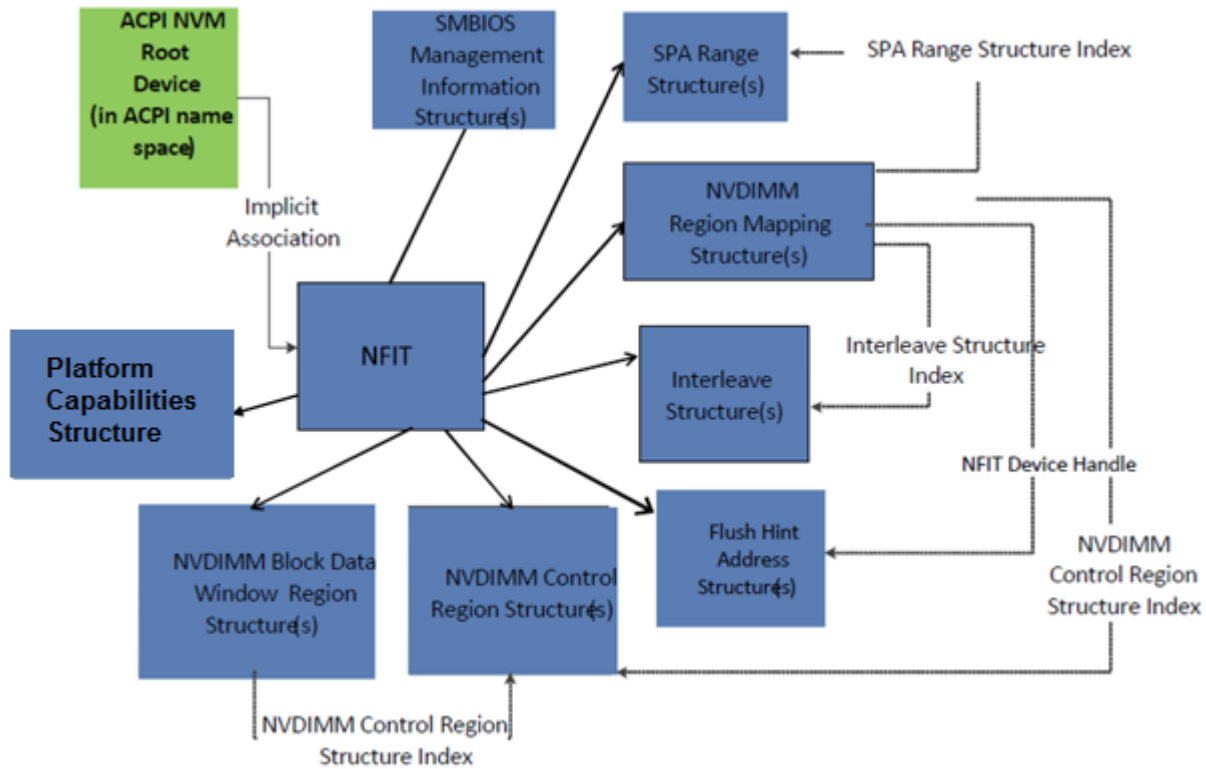

Fig. 5.9: NVDIMM Firmware Interface Table (NFIT) Overview

The following table defines the NFIT.

Table 5.126: NVDIMM Firmware Interface Table (NFIT)

Field	Byte Length	Byte Offset	Description
Header			
- Signature	4	0	'NFIT' is Signature for this table
- Length	4	4	Length in bytes for entire table.
- Revision	1	8	1
- Checksum	1	9	Entire table must sum to zero
- OEMID	6	10	OEM ID
- OEM Table ID	8	16	The table ID is the manufacturer model ID
- OEM Revision	4	24	OEM revision of table for supplied OEM Table ID
- Creator ID	4	28	Vendor ID of utility that created the table
- Creator Revision	4	32	Revision of utility that created the table
Reserved	4	36	NFIT Structure[n]
—	40	A list of NFIT structures for this implementation.	Each NFIT Structure must start with a 2 byte Type field followed by a 2 byte length field. This allows OSPM to ignore unrecognized types. Supported NFIT Structure types are listed in Table 5.127.

Table 5.127: NFIT Structure Types

Value	Description
0	System Physical Address (SPA) Range Structure
1	NVDIMM Region Mapping Structure
2	Interleave Structure
3	SMBIOS Management Information Structure
4	NVDIMM Control Region Structure
5	NVDIMM Block Data Window Region Structure
6	Flush Hint Address Structure
7	Platform Capabilities Structure
8-0xFFFF	Reserved

5.2.26.2 System Physical Address (SPA) Range Structure

This structure describes the system physical address ranges occupied by NVDIMMs, and their corresponding Region Types.

System physical address ranges described as Virtual CD or Virtual Disk shall be described as AddressRangeReserved in E820, and EFI Reserved Memory Type in the UEFI GetMemoryMap.

Platform is allowed to implement this structure just to describe system physical address ranges that describe Virtual CD and Virtual Disk. For Virtual CD Region and Virtual Disk Region (both volatile and persistent), the following fields - Proximity Domain, SPA Range Structure Index, Flags, and Address Range Memory Mapping Attribute, are not relevant and shall be set to 0.

The default mapping of the NVDIMM Control Region shall be UC memory attributes with AddressRangeReserved type in E820 and EfiMemoryMappedIO type in UEFI GetMemoryMap. The default mapping of the NVDIMM Block Data Window Region shall be WB memory attributes with AddressRangeReserved type in E820 and EfiMemoryMappedIO type in UEFI GetMemoryMap.

Table 5.128: SPA Range Structure

Field	Byte Length	Byte Offset	Description
Type	2	0	0 - SPA Range Structure
Length	2	2	Length in bytes for entire structure.
SPA Range Structure Index	2	4	Used by NVDIMM Region Mapping Structure to uniquely refer to this structure. Value of 0 is Reserved and shall not be used as an index.
Flags	2	6	Bit [0] set to 1 indicates that Control region is strictly for management during hot add/online operation. Bit [1] set to 1 to indicate that data in the Proximity Domain field is valid. Bit [2] set to 1 to indicate that data in the SPALocationCookie field is valid. Bits [15:3]: <i>Reserved</i>
Reserved	4	8	Reserved
Proximity Domain	4	12	Integer that represents the proximity domain to which the memory belongs. This number must match with corresponding entry in the SRAT table.

continues on next page

Table 5.128 – continued from previous page

Field	Byte Length	Byte Offset	Description
Address Range Type GUID	16	16	GUID that defines the type of the Address Range Type. The GUID can be any of the values defined in this section, or a vendor defined GUID.
System Physical Address Range Base	8	32	Start Address of the System Physical Address Range
System Physical Address Range Length	8	40	Range Length of the region in bytes
Address Range Memory Mapping Attribute	8	48	Memory mapping attributes for this address range: EFI_MEMORY_UC = 0x00000001 EFI_MEMORY_WC = 0x00000002 EFI_MEMORY_WT = 0x00000004 EFI_MEMORY_WB = 0x00000008 EFI_MEMORY_UCE = 0x00000010 EFI_MEMORY_WP = 0x00001000 EFI_MEMORY_RP = 0x00002000 EFI_MEMORY_XP = 0x00004000 EFI_MEMORY_NV = 0x00008000 EFI_MEMORY_MORE_RELIABLE = 0x00010000 EFI_MEMORY_RO = 0x00020000 EFI_MEMORY_SP = 0x00040000
SpaLocationCookie	8	56	Opaque cookie value set by platform firmware for OSPM use, to detect changes that may impact the readability of the data.

The following GUIDs are used to describe the NVDIMM Region Types. Additional GUIDs can be generated to describe additional Address Range Types.

Persistent Memory (PM) Region:

{ 0x66F0D379, 0xB4F3, 0x4074, 0xAC, 0x43, 0x0D, 0x33, 0x18, 0xB7, 0x8C, 0xDB }

NVDIMM Control Region:

{ 0x92F701F6, 0x13B4, 0x405D, 0x91, 0x0B, 0x29, 0x93, 0x67, 0xE8, 0x23, 0x4C }

NVDIMM Block Data Window Region:

{ 0x91AF0530, 0x5D86, 0x470E, 0xA6, 0xB0, 0x0A, 0x2D, 0xB9, 0x40, 0x82, 0x49 }

RAM Disk supporting a Virtual Disk Region - Volatile (a volatile memory region that contains a raw disk format):

{ 0x77AB535A, 0x45FC, 0x624B, 0x55, 0x60, 0xF7, 0xB2, 0x81, 0xD1, 0xF9, 0x6E }

RAM Disk supporting a Virtual CD Region - Volatile (a volatile memory region that contains an ISO image):

{ 0x3D5ABD30, 0x4175, 0x87CE, 0x6D, 0x64, 0xD2, 0xAD, 0xE5, 0x23, 0xC4, 0xBB }

RAM Disk supporting a Virtual Disk Region - Persistent (a persistent memory region that contains a raw disk format):

{ 0x5CEA02C9, 0x4D07, 0x69D3, 0x26, 0x9F, 0x44, 0x96, 0xFB, 0xE0, 0x96, 0xF9 }

RAM Disk supporting a Virtual CD Region - Persistent (a persistent memory region that contains an ISO image):

{ 0x08018188, 0x42CD, 0xBB48, 0x10, 0x0F, 0x53, 0x87, 0xD5, 0x3D, 0xED, 0x3D }

Note: The Address Range Type GUID values used in the ACPI NFIT must match the corresponding values in the Disk Type GUID of the RAM Disk device path that describe the same RAM Disk Type. Refer to the UEFI specification for details.

5.2.26.3 NVDIMM Region Mapping Structure

The NVDIMM Region Mapping structure describes an NVDIMM region and its mapping, if any, to an SPA range.

Table 5.129: NVDIMM Region Mapping Structure

Field	Byte Length	Byte Offset	Description
Type	2	0	1 - NVDIMM Region Mapping Structure
Length	2	2	Length in bytes for entire structure.
NFIT Device Handle	4	4	The <code>_ADR</code> of the NVDIMM device (see Section 9.19.3) containing the NVDIMM region
NVDIMM Physical ID	2	8	Handle (i.e., instance number) for the SMBIOS Memory Device (Type 17) structure describing the NVDIMM containing the NVDIMM region. See the <i>DSP0134 System Management BIOS (SMBIOS) Reference Specification, Version 3.0.0</i> (2015-02-12) by the Distributed Management Task Force, Inc. (DMTF) at http://www.dmtf.org/standards/smbios
NVDIMM Region ID	2	10	Unique identifier for the NVDIMM region. This identifier shall be unique across all the NVDIMM regions in the NVDIMM. There could be multiple regions within the device corresponding to different address types. Also, for a given address type, there could be multiple regions due to interleave discontinuity.
SPA Range Structure Index	2	12	The SPA range, if any, associated with the NVDIMM region:: 0x0000: The NVDIMM region does not map to a SPA range. The following fields are not valid and should be ignored: - NVDIMM Region Size; - Region Offset; - NVDIMM Physical Address Region Base; - Interleave Structure Index; and - Interleave Ways. Fields other than the above (e.g. NFIT Device Handle, NVDIMM Physical ID, NVDIMM Region ID, and NVDIMM State Flags) are valid: - 0x0001 to 0xFFFF: The index of the SPA Range Structure (see Section 5.2.26.2) for the NVDIMM region.
NVDIMM Control Region Structure Index	2	14	The index of the NVDIMM Control Region Structure (see Section 5.2.26.6) for the NVDIMM region.

continues on next page

Table 5.129 – continued from previous page

Field	Byte Length	Byte Offset	Description
NVDIMM Region Size	8	16	The size of the NVDIMM region, in bytes. If SPA Range Structure Index and Interleave Ways are both non-zero, this field shall match System Physical Address Range Length divided by Interleave Ways. NOTE: the size in SPA Range occupied by the NVDIMM for this region will not be the same as the NVDIMM Region Size when Interleave Ways is greater than 1.
Region Offset	8	24	In bytes: The Starting Offset for the NVDIMM region in the Interleave Set. This offset is with respect to System Physical Address Range Base in the SPA Range Structure. NOTE: The starting SPA of the NVDIMM region in the NVDIMM is provided by System Physical Address Range Base + Region Offset
NVDIMM Physical Address Region Base	8	32	In bytes. The base physical address within the NVDIMM of the NVDIMM region.
Interleave Structure Index	2	40	The <i>Interleave Structure</i> , if any, for the NVDIMM region, as defined in Table 5.130.
Interleave Ways	2	42	Number of NVDIMMs in the interleave set, including the NVDIMM containing the NVDIMM region, as defined in Table 5.130.

continues on next page

Table 5.129 – continued from previous page

Field	Byte Length	Byte Offset	Description
NVDIMM State Flags	2	44	<p>Bit [0] set to 1 indicates that the previous SAVE operation to the NVDIMM containing the NVDIMM region failed.</p> <p>Bit [0] set to 0 indicates that the previous SAVE succeeded, or there was no previous SAVE.</p> <p>Bit [1] set to 1 indicates that the last RESTORE operation from the NVDIMM containing the NVDIMM region failed.</p> <p>Bit [1] set to 0 indicates that the last RESTORE succeeded or there was no last RESTORE.</p> <p>Bit [2] set to 1 indicates that the platform flush of data to the NVDIMM containing the NVDIMM region before the previous SAVE failed. As a result, the restored data content may be inconsistent even if Bit [0] and Bit [1] do not indicate failure.</p> <p>Bit [2] set to 0 indicates that the platform flush succeeded, or there was no platform flush.</p> <p>Bit [3] set to 1 indicates that the NVDIMM containing the NVDIMM region is not able to accept persistent writes. For an energy-source backed NVDIMM device, Bit [3] is set if it is not armed or the previous ERASE operation did not complete.</p> <p>Bit [3] set to 0 indicates that the NVDIMM containing the NVDIMM region is armed.</p> <p>Bit [4] set to 1 indicates that the NVDIMM containing the NVDIMM region observed SMART and health events prior to OSPM handoff.</p> <p>Bit [5] set to 1 indicates that platform firmware is enabled to notify OSPM of SMART and health events related to the NVDIMM containing the NVDIMM region using Notify codes as specified in NVDIMM Device Notification Values.</p> <p>Bit [6] set to 1 indicates that the platform firmware did not map the NVDIMM containing the NVDIMM region into an SPA range. This could be due to various issues such as a device initialization error, device error, insufficient hardware resources to map the device, or a disabled device.</p> <p>Implementation Note: In case of device error, Bit [4] might be set along with Bit [6].</p> <p>Bit [7] to Bit [15] are reserved.</p> <p>Implementation Note: Platform firmware might report several set bits.</p>
<i>Reserved</i>	2	46	Reserved

Table 5.130: Interleave Structure Index and Interleave Ways definition

Interleave Structure Index	Interleave Ways	Interpretation
0	0	Interleaving, if any, of the NVDIMM region is not reported
0	1	The NVDIMM region is not interleaved with other NVDIMMs (i.e., it is one-way interleaved)
0	>1	The NVDIMM region is part of an interleave set with the number of NVDIMMs indicated in the Interleave Ways field, including the NVDIMM containing the NVDIMM region, but the Interleave Structure is not described.
> 0	> 1	The NVDIMM region is part of an interleave set with: a) the number of NVDIMMs indicated in the Interleave Ways field, including the NVDIMM containing the NVDIMM region; and b) the Interleave Structure (see Section 5.2.26.4) indicated by the Interleave Structure Index field.
All other combinations		Invalid case

Note: Interleave Structure Index=0, Interleave Ways !=1 is to allow a PM range which is interleaved but the actual interleave is not described but only provides the physical Memory Devices (as described by SMBIOS Type 17) that contribute to the PM region. Typically, only block region requires the interleave structure since software has to undo the effect of interleave.

5.2.26.4 Interleave Structure

Memory from DIMMs/NVDIMMs could be interleaved across memory channels, memory controller and processor sockets. This structure describes the memory interleave for a given address range. Since interleave is a repeating pattern, this structure only describes the lines involved in the memory interleave before the pattern start to repeat.

Table 5.131: Interleave Structure

Field	Byte Length	Byte Offset	Description
Type	2	0	2 - Interleave Structure
Length	2	2	Length in bytes for entire structure.
Interleave Structure Index	2	4	Index Number uniquely identifies the interleave description - this allows reuse of interleave description across multiple NVDIMMs. Index must be non-zero.
Reserved	2	6	
Number of Lines Described (m)	4	8	Only need to describe the number of lines needed before the interleave pattern repeats
Line Size (in bytes)	4	12	e.g. 64, 128, 256, 4096
Line 1 Offset	4	16	Line 1 Offset refers to the offset of the line, in multiples of Line Size, from the corresponding SPA Range Base for the NVDIMM region. Line 1 SPA = SPA Range Base + Region Offset + (Line 1 Offset*Line Size). Line SPA is naturally aligned to the Line size.
...	4		

continues on next page

Table 5.131 – continued from previous page

Field	Byte Length	Byte Offset	Description
Line m Offset	4	16+((m-1)*4)	Line m Offset refers to the offset of the line, in multiples of Line Size, from the corresponding SPA Range Base for the NVDIMM region. Line m SPA = SPA Range Base + Region Offset + (Line m Offset*Line Size) where m is the last line number before the pattern repeats.

5.2.26.5 SMBIOS Management Information Structure

This structure enables platform to communicate the additional SMBIOS entries beyond the entries provided by SMBIOS Table at boot to the OS (e.g. Type 17 entries corresponding to hot added NVDIMMs).

Table 5.132: SMBIOS Management Information Structure

Field	Byte Length	Byte Offset	Description
Type	2	0	3 - SMBIOS Management Information Structure
Length	2	2	Length in bytes for entire structure.
Reserved	4	4	
Data	–	8	SMBIOS Table Entries

5.2.26.6 NVDIMM Control Region Structure

The system shall include an NVDIMM Control Region Structure for every Function Interface in the NVDIMM.

Table 5.133: NVDIMM Control Region Structure Mark

Field	Byte Length	Byte Offset	Description
Type	2	0	4 - NVDIMM Control Region Structure
Length	2	2	Length in bytes for entire structure. The length of this structure is either 32 bytes or 80 bytes. The length of the structure can be 32 bytes only if the Number of Block Control Windows field has a value of 0.
NVDIMM Control Region Structure Index	2	4	Index Number uniquely identifies the NVDIMM Control Region Structure.
Vendor ID	2	6	Identifier indicating the vendor of the NVDIMM. This field shall be set to the value of the NVDIMM SPD Module Manufacturer ID Code field ^(a) with byte 0 set to DDR4 SPD byte 320 and byte 1 set to DDR4 SPD byte 321.
Device ID	2	8	Identifier for the NVDIMM, assigned by the module vendor. This field shall be set to the value of the NVDIMM SPD Module Product Identifier field ^(b) with byte 0 set to SPD byte 192 and byte 1 set to SPD byte 193.
Revision ID	2	10	Revision of the NVDIMM, assigned by the module vendor. Byte 1 of this field is reserved. Byte 0 of this field shall be set to the value of the NVDIMM SPD Module Revision Code field ^(a) (i.e., SPD byte 349).

continues on next page

Table 5.133 – continued from previous page

Field	Byte Length	Byte Offset	Description
Subsystem Vendor ID	2	12	Vendor of the NVDIMM non-volatile memory subsystem controller ^(c) . This field shall be set to the value of the NVDIMM SPD Non-Volatile Memory Subsystem Controller Vendor ID field ^(b) with byte 0 set to SPD byte 194 and byte 1 set to SPD byte 195.
Subsystem Device ID	2	14	Identifier for the NVDIMM non-volatile memory subsystem controller, assigned by the non-volatile memory subsystem controller vendor. This field shall be set to the value of the NVDIMM SPD Non-Volatile Memory Subsystem Controller Device ID field ^(b) with byte 0 set to SPD byte 196 and byte 1 set to SPD byte 197.
Subsystem Revision ID	2	16	Revision of the NVDIMM non-volatile memory subsystem controller, assigned by the non-volatile memory subsystem controller vendor. Byte 1 of this field is reserved. Byte 0 of this field shall be set to the value of the NVDIMM SPD Non-Volatile Memory Subsystem Controller Revision Code field ^b (i.e. SPD byte 198).
Valid Fields	1	18	Valid bits for fields defined after the initial NFIT definition in ACPI 6.0 within the initially defined lengths of 32 and 80 bytes. Bits [7-1]: Reserved. Bit [0]: Manufacturing Location field and Manufacturing Date field. Bit [0] set to one indicates that the Manufacturing Location field and Manufacturing Date field are valid. Bit [0] set to zero indicates that the Manufacturing Location field and Manufacturing Date field are not valid and should be ignored. Systems compliant with this specification shall set Bit [0] to one. Systems that were compliant with ACPI 6.0 had Bit [0] set to zero, meaning they did not have Manufacturing Location and Manufacturing Date fields.
Manufacturing Location	1	19	Manufacturing location for the NVDIMM, assigned by the module vendor. This field shall be set to the value of the NVDIMM SPD Module Manufacturing Location field ^a (SPD byte 322). Validity of this field is indicated in Valid Fields Bit [0].
Manufacturing Date	2	20	Date the NVDIMM was manufactured, assigned by the module vendor. This field shall be set to the value of the NVDIMM SPD Module Manufacturing Date field ^(a) with byte 0 set to SPD byte 323 and byte 1 set to SPD byte 324. Validity of this field is indicated in Valid Fields Bit [0].
<i>Reserved</i>	2	22	Reserved
Serial Number	4	24	Serial number of the NVDIMM, assigned by the module vendor. This field shall be set to the value of the NVDIMM SPD Module Serial Number field with byte 0 set to SPD byte 325, byte 1 set to SPD byte 326, byte 2 set to SPD byte 327, and byte 3 set to SPD byte 328.

continues on next page

Table 5.133 – continued from previous page

Field	Byte Length	Byte Offset	Description
Region Format Interface Code	2	28	<p>Identifier for the programming interface. This field shall be set to the value of the NVDIMM SPD Function Interface descriptor ^b for the function interface represented by the NVDIMM Control Region structure, with:</p> <ul style="list-style-type: none"> a. byte 0 bits 7:5 set to 000b; b. byte 0 bits 4:0 set to the Function Interface field (Function Interface descriptor bits 4:0); c. byte 1 bits 7:5 set to 000b; and d. byte 1 bits 4:0 set to the Function Class field (Function Interface descriptor bits 9:5). <p>EXAMPLE - A Function Interface Descriptor of 0x8021 means:</p> <ul style="list-style-type: none"> a. Function Interface Descriptor is implemented; b. there is no Extended Function Parameter Block; c. function class is byte-addressable energy backed (0x01); and d. function interface is byte addressable energy backed function interface 1 (0x01) ^d, and maps to a Region Format Interface Code of 0x0101.
Number of Block Control Windows	2	30	Number of Block Control Windows must match the corresponding number of Block Data Windows. Fields that follow this field are valid only if the number of Block Control Windows is non-zero.
Size of Block Control Window	8	32	In Bytes
Command Register Offset in Block Control Window	8	40	In Bytes. Logical offset. Refer to Note. The start of the subsequent Block Control Windows is calculated by adding Size of Block Control Window.
Size of Command Register in Block Control Windows	8	48	In Bytes
Status Register Offset in Block Control Window	8	56	Logical offset in bytes. Refer to Note1. The start of the subsequent Block Control Window is calculated by adding Size of Block Control Window.
Size of Status Register in Block Control Windows	8	64	In Bytes
NVDIMM Control Region Flag	2	72	Bit [0] set to 1 to indicate that the Block Data Windows implementation is buffered. The content of the data window is only valid when so indicated by Status Register.
<i>Reserved</i>	6	74	Reserved

Notes for above table:

- (a) See JEDEC Standard No. 21-C *JEDEC Configurations for Solid State Memories* , Annex L: Serial Presence Detect (SPD) for DDR4 SDRAM modules, DDR4 SPD Document Release 2.
- (b) See JEDEC Standard No. 21-C *JEDEC Configurations for Solid State Memories* , Annex L: Serial Presence Detect (SPD) for DDR4 SDRAM modules, DDR4 SPD Document Release 3 (forthcoming).

- (c) In an NVDIMM, the module contains a non-volatile memory subsystem controller.
- (d) See JEDEC Standard No. 2233-22 *Byte Addressable Energy Backed Interface*, Version 1.0 (forthcoming).

Note: “Logical offset” in the structure above refers to the offset from the start of NVDIMM Control Region. The logical offset is with respect to the device, not with respect to system physical address space. Software should construct the device address space (accounting for interleave) before applying the block control start offset.

5.2.26.7 NVDIMM Block Data Window Region Structure

This structure shall be provided only if the number of Block Data Windows is non-zero.

Table 5.134: NVDIMM Block Data Windows Region Structure

Field	Byte Length	Byte Offset	Description
Type	2	0	5 - NVDIMM Block Data Window Region Structure
Length	2	2	Length in bytes for entire structure.
NVDIMM Control Region Structure Index	2	4	Provides association for the corresponding NVDIMM Control Region. Shall be Non-zero.
Number of Block Data Windows	2	6	Number of Block Data Windows shall match the corresponding number of Block Control Windows.
Block Data Window Start Offset	8	8	Logical offset in bytes (see note below). The start of the subsequent Block Data Window is calculated by adding Size of Block Data Window.
Size of Block Data Window	8	16	In Bytes
Block Accessible Memory Capacity	8	24	In Bytes
Beginning address of first block in Block Accessible Memory	8	32	In Bytes. The address of the next block is obtained by adding the value of this field to Size of Block Data Window.

Note: Logical offset in table above refers to offset from the start of NVDIMM Data Window Region. The logical offset is with respect to the device not with respect to system physical address space. Software should construct the device address space (accounting for interleave) before applying the Block Data Window start offset.

5.2.26.8 Flush Hint Address Structure

Software needs an assurance of durability (i.e. a guarantee that the writes have reached the target NVDIMM) after writing to a NVDIMM region. The Flush Hint feature is platform specific and if supported, the platform exposes this durability mechanism to OSPM by providing a Flush Hint Address Structure.

For a given NVDIMM (as indicated by the NFIT Device Handle in the Flush Hint Address Structure), software can write to any one of these Flush Hint Addresses to cause any preceding writes to the NVDIMM region to be flushed out of the intervening platform buffers to the targeted NVDIMM (to achieve durability). Note that the platform buffers do not include processor cache(s)! Processors typically include ISA to flush data out of processor caches.

Table 5.135: Flush Hint Address Structure

Field	Byte Length	Byte Offset	Description
Type	2	0	6 - Flush Hint Address Structure
Length	2	2	Length in bytes for entire structure.
NFIT Device Handle	4	4	Indicates the NVDIMM supported by the Flush Hint Addresses in this structure.
Number of Flush Hint Addresses in this structure (m)	2	8	Number of Flush Hint Addresses in this structure.
Reserved	6	10	Reserved
Flush Hint Address 1	8	16	64-bit system physical address that needs to be written to cause durability flush. Software is allowed to write up to a cache line of data. The content of the data is not relevant to the functioning of the flush hint mechanism.
...	8	24	
Flush Hint Address m	8	16+ ((m-1)*8)	64-bit system physical address that needs to be written to cause durability flush. Software is allowed to write up to a cache line of data. The content of the data is not relevant to the functioning of the flush hint mechanism.

5.2.26.9 Platform Capabilities Structure

This structure informs OSPM of the NVDIMM platform capabilities.

Table 5.136: Platform Capabilities Structure

Field	Byte Length	Byte Offset	Description
Type	2	0	7 - Platform Capabilities Structure
Length	2	2	Length in bytes for entire structure.
Highest Valid Capability	1	4	The bit index of the highest valid capability implemented by the platform. The subsequent bits shall not be considered to determine the capabilities supported by the platform.
Reserved	3	5	Reserved (0)

continues on next page

Table 5.136 – continued from previous page

Field	Byte Length	Byte Offset	Description
Capabilities	4	8	<p>Bit[0] - CPU Cache Flush to NVDIMM Durability on Power Loss Capable. If set to 1, indicates that platform ensures the entire CPU store data path is flushed to persistent memory on system power loss.</p> <p>Bit[1] - Memory Controller Flush to NVDIMM Durability on Power Loss Capable. If set to 1, indicates that platform provides mechanisms to automatically flush outstanding write data from the memory controller to persistent memory in the event of platform power loss. Note: If bit 0 is set to 1 then this bit shall be set to 1 as well.</p> <p>Bit[2] - Byte Addressable Persistent Memory Hardware Mirroring Capable. If set to 1, indicates that platform supports mirroring multiple byte addressable persistent memory regions together. If this feature is supported and enabled, healthy hardware mirrored interleave sets will have the EFI_MEMORY_MORE_RELIABLE Address Range Memory Mapping Attribute set in the System Physical Address Range structure in the NFIT table.</p> <p>Bits[31:3] - Reserved</p>
Reserved	4	12	Reserved (1)

5.2.26.10 NVDIMM Representation Format

If software or an NVDIMM manufacturer displays, prints on a label, or otherwise makes available an identifier for an NVDIMM (e.g., to uniquely identify the NVDIMM), then the following hexadecimal format should be used:

- If the Manufacturing Location and Manufacturing Date fields are valid:

```
C language format string: "%02x%02x-%02x-%02x%02x-%02x%02x%02x%02x"
```

Format values:

1. Vendor ID byte 0 (including the parity bit)
 2. Vendor ID byte 1
 3. Manufacturing Location byte
 4. Manufacturing Date byte 0 (i.e., the year)
 5. Manufacturing Date byte 1 (i.e., the week)
 6. Serial Number byte 0
 7. Serial Number byte 1
 8. Serial Number byte 2
 9. Serial Number byte 3
- If the Manufacturing Location and Manufacturing Date fields are not valid:

```
C language format string: "%02x%02x-%02x%02x%02x%02x"
```

Format values:

1. Vendor ID byte 0 (including the parity bit)
2. Vendor ID byte 1
3. Serial Number byte 0
4. Serial Number byte 1
5. Serial Number byte 2
6. Serial Number byte 3

This format matches the order of SPD bytes 320 to 328 from low to high (i.e., showing the lowest or first byte on the left).

5.2.27 Secure Devices (SDEV) ACPI Table

The Secure DEVICES (SDEV) table is a list of secure devices known to the system. The table is applicable to systems where a secure OS partition and a non-secure OS partition co-exist. A secure device is a device that is protected by the secure OS, preventing accesses from non-secure OS.

The table provides a hint as to which devices should be protected by the secure OS. The enforcement of the table is provided by the secure OS and any pre-boot environment preceding it. The table itself does not provide any security guarantees. It is the responsibility of the system manufacturer to ensure that the operating system is configured to enable security features that make use of the SDEV table.

There are three options for each device in the system:

- 1) Device is listed in SDEV. “Allow handoff...” flag is clear. This provides a hint that the device should be always protected within the secure OS. For example, the secure OS may require that a device used for user authentication must be protected to guard against tampering by malicious software.
- 2) Device is listed in SDEV. “Allow handoff...” flag is set. This provides a hint that the device should be initially protected by the secure OS, but it is up to the discretion of the secure OS to allow the device to be handed off to the non-secure OS when requested. Any OS component that expected the device to be operating in secure mode would not correctly function after the handoff has been completed. For example, a device may be used for variety of purposes, including user authentication. If the secure OS determines that the necessary components for driving the device are missing, it may release control of the device to the non-secure OS. In this case, the device cannot be used for secure authentication, but other operations can correctly function.
- 3) Device not listed in SDEV. For example, the status quo is that no hints are provided. Any OS component that expected the device to be in secure mode would not correctly function.

The OS vendor provides guidance on which devices can be listed in the SDEV table. In other words, which devices are compatible with the secure OS, and which devices should have the “allow handoff” flag set.

See the following table for the SDEV ACPI definition.

Table 5.137: SDEV ACPI Table

Field	Byte Length	Byte Offset	Description
Header			
- Signature	4	0	‘SDEV’. Signature for the Table
- Length	4	4	Length, in bytes, of the entire Table.

continues on next page

Table 5.137 – continued from previous page

Field	Byte Length	Byte Offset	Description
- Revision	1	8	1
- Checksum	1	9	Entire table must sum to zero.
- OEM ID	6	10	OEM ID
- OEM Table ID	8	16	For the SDEV Table, the table ID is the manufacturer model ID.
- OEM Revision	4	24	OEM revision of SDEV Table for supplied OEM Table ID.
- Creator ID	4	28	Vendor ID of utility that created the table.
- Creator Revision	4	32	Revision of utility that created the table.
Secure Device Structures []	—	36	A list of structures containing one or more Secure Device Structures as defined in next section.

5.2.27.1 Secure Device Structures

Table 5.138: Secure Device Structures

Value	Description
0	ACPI_NAMESPACE_DEVICE based Secure Device.
1	PCIe Endpoint Device-based Secure Device.
All Other Values	Reserved for future use. For forward compatibility, software skips structures it does not comprehend by skipping the appropriate number of bytes indicated by the Length field. All new device structures must include the Type, Flags, and Length fields as the first 3 fields respectively.

5.2.27.1.1 ACPI_NAMESPACE_DEVICE based Secure Device Structure

Table 5.139: ACPI_NAMESPACE_DEVICE based Secure Device Structure

Field	Byte Length	Byte Offset	Description
Type	1	0	0x00: ACPI integrated devices
Flags	1	1	Bit 0: Allow handoff to non-secure OS. All other bits are reserved and must be zero. Bit 1: Secure Access Components present. All other bits are reserved and must be zero.
Length	2	2	Length of this entry in bytes.
Device Identifier Offset	2	4	Offset, in the Secure ACPI Device structure, of a null terminated ASCII string that contains a fully qualified reference to the ACPI namespace object that is this device. (For example, _SB.I2C0 represents the ACPI object name for an embedded I2C Device in southbridge; Quotes are omitted in the data field). Refer to ACPI specification for fully qualified references for ACPI name-space objects.
Device Identifier Length	2	6	Length of Device Identifier string in bytes, including the termination byte.

continues on next page

Table 5.139 – continued from previous page

Field	Byte Length	Byte Offset	Description
Vendor specific data Offset	2	8	Offset, in Secure ACPI Device Structure, of the data specific to the device supplied by the vendor.
Vendor specific data Length	2	10	Length of the data specific to the device supplied by the vendor.
Secure Access Components Offset	2	12	Offset, in ACPI_NAMESPACE_DEVICE based Secure Device Structure, of the list of Secure Access Components needed for device execution in a secure OS. Only present if the “secure access components present” bit is set.
Secure Access Components Length	2	14	Length of the list of Secure Access Components data. Only present if the “secure access components present” bit is set.

Table 5.140: Secure Access Component Types

Value	Description
0	Identification Based Secure Access Component. A minimum of one is required for a secure device. When there are multiple Identification Components present, priority is determined by list order. See Table 5.141
1	Memory Based Secure Access Component. See Table 5.142
All other values	Reserved for future use. For forward compatibility, software skips structures that it does not comprehend by skipping the appropriate number of bytes indicated by the Length field. All new device structures must include the Type, Flags, and Length fields as the first 3 fields, respectively.

Table 5.141: Identification Based Secure Access Component

Field	Byte Length	Byte Offset	Description
Type	1	0	0x00: Identification Component. See Table 5.140
Flags	1	1	Reserved for future use.
Length	2	2	Length of this Entry in Bytes.
Hardware Identifier Offset	2	4	Offset, in Identification Component Structure, of a null terminated ASCII string that contains the Hardware Identifier. The Hardware Identifier is a PNP or ACPI ID. A valid PNP ID must be of the form “AAA#####” where A is an uppercase letter and # is a hex digit. A valid ACPI ID must be of the form “NNNN#####” where N is an uppercase letter or a digit. The Hardware Identifier is a required field.
Hardware Identifier Length	2	6	Length of the Hardware Identifier in bytes including the termination byte.

continues on next page

Table 5.141 – continued from previous page

Field	Byte Length	Byte Offset	Description
Subsystem Identifier Offset	2	8	Offset, in Identification Component Structure, of a null terminated ASCII string that contains the Subsystem Identifier. The Subsystem Identifier is a PNP or ACPI ID. The Hardware Identifier is a PNP or ACPI ID. A valid PNP ID must be of the form “AAA####” where A is an uppercase letter and # is a hex digit. A valid ACPI ID must be of the form “NNNN####” where N is an uppercase letter or a digit. The Subsystem Identifier is optional. If a Subsystem Identifier is not present. This value should be 0.
Subsystem Identifier Length	2	10	Length of the Subsystem Identifier in bytes including the termination byte.
Hardware Revision	2	12	The Hardware Revision.
Hardware Revision Present	1	14	If 0, the Hardware Revision is ignored.
Class Code Present	1	15	If 0, the PCI-Compatible Class code is ignored.
PCI-Compatible Base-Class	1	16	The PCI-Compatible Base-Class code.
PCI-Compatible Sub-Class	1	17	The PCI-Compatible Sub-Class code.
PCI-Compatible Programming Interface	1	18	The PCI-Compatible Programming Interface Code.

Table 5.142: Memory-based Secure Access Component

Field	Byte Length	Byte Offset	Description
Type	1	0	0x01: Memory Component.
Flags	1	1	Reserved for future use.
Length	2	2	Length of this Entry in Bytes.
Reserved	4	4	Padding.
Memory Address Base	8	8	Starting address of the memory component.
Memory Length	8	16	Length of the memory component in Bytes.

5.2.27.1.2 PCIe Endpoint Device-based Device Structure

Table 5.143: PCIe Endpoint Device-based Device Structure

Field	Byte Length	Byte Offset	Description
Type	1	0	0x01: PCIe Endpoint device.
Flags	1	1	Bit 0: Allow handoff to non-secure OS. All other bits are reserved and must be zero.
Length	2	2	Length of this Entry in Bytes.

continues on next page

Table 5.143 – continued from previous page

Field	Byte Length	Byte Offset	Description
PCI Segment Number	2	4	PCI segment number of the device .
Start Bus Number	2	6	This field describes the bus number (bus number of the first PCI Bus produced by the PCI Host Bridge) under which the secure device resides.
PCI Path Offset	2	8	Pointer to the PCI path entry offset in the Secure PCI Device Structure data region. A PCI Path describes the hierarchal path from the Host Bridge to the device. For example, a device in an N-deep hierarchy is identified by N {PCI Device Number, PCI Function Number} pairs, where N is a positive integer. Even numbered offsets contain the Device numbers, and odd numbered offsets contain the Function numbers. The first {Device, Function} pair resides on the bus identified by the ‘Start Bus Number’ field. Each subsequent pair resides on the bus directly behind the bus of the device identified by the previous pair. The identity (Bus, Device and Function) of the target device is obtained by recursively walking down these N {Device, Function} pairs.
PCI Path Length	2	10	Length of the PCI path entry.
Vendor specific data Offset	2	12	Offset of the data specific to the device.
Vendor specific data Length	2	14	Length of the data specific to the device.

Example

The following table is an example for implementing a PCIe Endpoint Device Based Device Structure for a PCIe device (Bus 1, Dev 2, Function 1), that is a child of a PCIe Root Port (Bus 0, Dev 18, Function 0).

Table 5.144: PCIe Endpoint Device-based Device Structure Example

Field	Byte Length	Byte Offset	Value
Type	1	0	0x01: PCIe Endpoint device.
Flags	1	1	0x01
Length	2	2	0x18
PCI Segment Number	2	4	0x0
Start Bus Number	2	6	0x0
PCI Path Offset	2	8	0x10 (16 DEC)
PCI Path Length	2	10	0x4
Vendor-specific data Offset	2	12	0x14 (20 DEC)
Vendor-specific data Length	2	14	0x4
PCI Path			
PCI Device	1	16	0x12 (18 DEC)
PCI Function	1	17	0x0
PCI Device	1	18	0x2
PCI Function	1	19	0x1
Vendor specific data	4	20	0xDEADBEEF

5.2.28 Heterogeneous Memory Attribute Table (HMAT)

5.2.28.1 HMAT Overview

The Heterogeneous Memory Attribute Table (HMAT) describes the memory attributes, such as memory side cache attributes and bandwidth and latency details, related to Memory Proximity Domains. The software is expected to use this information as a hint for optimization, or when the system has heterogeneous memory.

OSPM evaluates HMAT only during system initialization. Any changes to the HMAT state at runtime or information regarding HMAT for hot plug are communicated using the `_HMA` method.

The HMAT consists of the following structures:

1. Memory Proximity Domain Attributes Structure(s). Describes attributes of memory proximity domains. See Table 5.147.
2. System Locality Latency and Bandwidth Information Structure(s). Describes the memory access latency and bandwidth information from various memory access initiator proximity domains. See Section 5.2.28.4. The optional access mode and transfer size parameters indicate the conditions under which the Latency and Bandwidth are achieved.
3. Memory Side Cache Information Structure(s). Describes memory side cache information for memory proximity domains if the memory side cache is present and the physical device (SMBIOS handle) forms the memory side cache. See Table 5.149.

These structures are illustrated by the following figure.

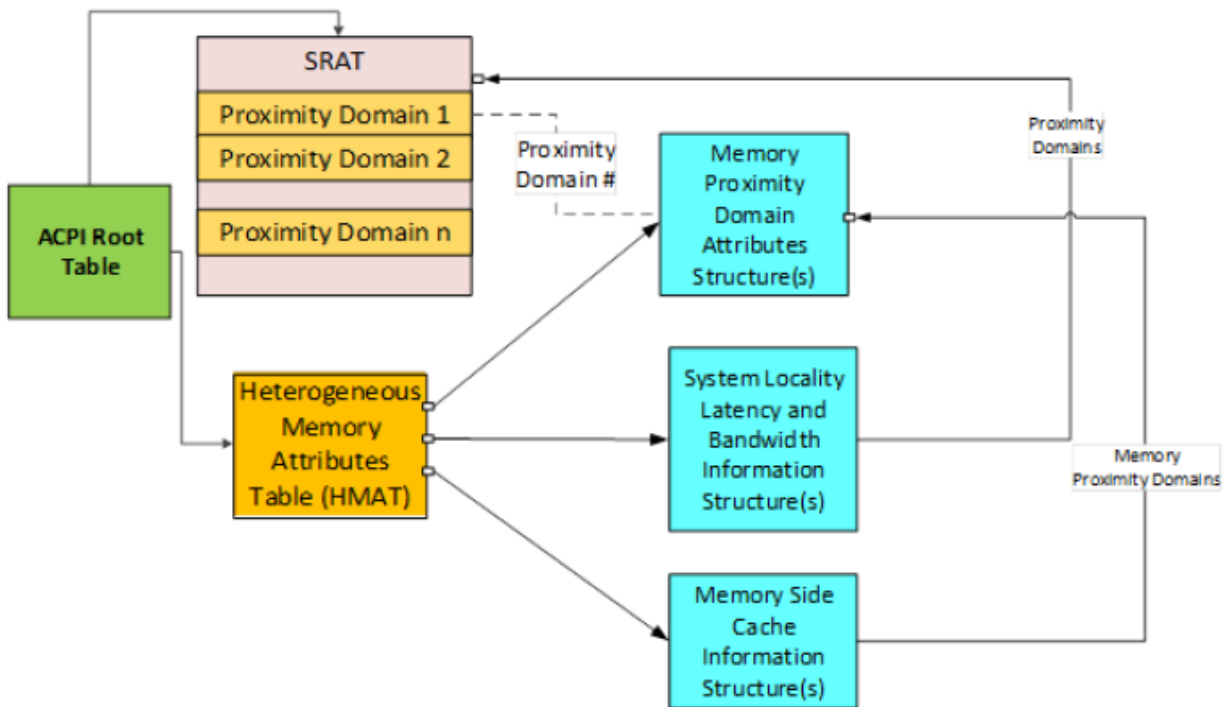

Fig. 5.10: HMAT Representation

Table 5.145: Heterogeneous Memory Attribute Table Header

Field	Byte Length	Byte Offset	Description
Header			
- Signature	4	0	'HMAT' is Signature for this table
- Length	4	4	Length in bytes for entire table.
- Revision	1	8	2
- Checksum	1	9	Entire table must sum to zero
- OEMID	6	10	OEM ID
- OEM Table ID	8	16	The table ID is the manufacturer model ID
- OEM Revision	4	24	OEM revision of table for supplied OEM Table ID
- Creator ID	4	28	Vendor ID of utility that created the table
- Creator Revision	4	32	Revision of utility that created the table
Reserved	4	36	To make the structures 8 byte aligned
HMAT Table Structures[n]	—	40	A list of HMAT table structures for this implementation.

Table 5.146: HMAT Structure Types

Value	Description
0	Memory Proximity Domain Attributes Structure
1	System Locality Latency and Bandwidth Information Structure
2	Memory Side Cache Information Structure
3-0xFFFF	Reserved

5.2.28.2 Memory Side Cache Overview

Memory side cache allows to optimize the performance of memory subsystems. Fig. 5.11 shows an example of system physical address (SPA) range with memory side cache in front of actual memory that is seen by the software. When the software accesses an SPA, if it is present in the near memory (hit) it would be returned to the software, if it is not present in the near memory (miss) it would access the next level of memory and so on.

The term “far memory” is used to denote the last level memory (Level 0 Memory) in the memory hierarchy as shown in Fig. 5.11. The Level n Memory acts as memory side cache to Level n-1 Memory and Level n-1 memory acts as memory side cache for Level n-2 memory and so on. If Non-Volatile memory is cached by memory side cache, then platform is responsible for persisting the modified contents of the memory side cache corresponding to the Non-Volatile memory area on power failure, system crash or other faults.

5.2.28.3 Memory Proximity Domain Attributes Structure

This structure describes the system physical address (SPA) range occupied by the memory subsystem and its associativity with processor proximity domain as well as hint for memory usage.

Table 5.147: Memory Proximity Domain Attributes Structure

Field	Byte Length	Byte Offset	Description
Type	2	0	0 - Memory Proximity Domain Attributes Structure
Reserved	2	2	
Length	4	4	40 - Length in bytes for entire structure.

continues on next page

Table 5.147 – continued from previous page

Field	Byte Length	Byte Offset	Description
Flags	2	8	Bit [0]: set to 1 to indicate that data in the Proximity Domain for the Attached Initiator field is valid. Bit [1]: Reserved. Previously defined as Memory Proximity Domain field is valid. Deprecated since ACPI 6.3. Bit [2]: Reserved. Previously defined as Reservation Hint. Deprecated since ACPI 6.3. Bits [15:3] : Reserved.
Reserved	2	10	
Proximity Domain for the Attached Initiator	4	12	This field is valid only if the memory controller responsible for satisfying the access to memory belonging to the specified memory proximity domain is directly attached to an initiator that belongs to a proximity domain. In that case, this field contains the integer that represents the proximity domain to which the initiator (Generic Initiator or Processor) belongs. This number shall match the corresponding entry in the SRAT table's processor affinity structure (e.g., Processor Local APIC/SAPIC Affinity Structure, Processor Local x2APIC Affinity Structure, GICC Affinity Structure) if the initiator is a processor, or the Generic Initiator Affinity Structure if the initiator is a generic initiator. Note: this field provides additional information as to the initiator node that is closest (as in directly attached) to the memory address ranges within the specified memory proximity domain, and therefore should provide the best performance.
Proximity Domain for the Memory	4	16	Integer that represents the memory proximity domain to which this memory belongs.
Reserved	4	20	
Reserved	8	24	Previously defined as the Start Address of the System Physical Address Range. Deprecated since ACPI Specification 6.3.
Reserved	8	32	Previously defined as the Range Length of the region in bytes. Deprecated since ACPI Specification 6.3.

5.2.28.4 System Locality Latency and Bandwidth Information Structure

This structure provides a matrix that describes the normalized memory read/write latency, the read/write bandwidth between Initiator Proximity Domains (Processor or I/O) and Target Proximity Domains (Memory).

The Entry Base Unit for latency is in picoseconds. The Entry Base Unit for bandwidth is in megabytes per second (MB/s). The Initiator to Target Proximity Domain matrix entry can have one of the following values:

- 1-0xFFFFE: the corresponding latency or bandwidth information expressed in multiples of Entry Base Unit.
- 0xFFFFF: the initiator and target domains are unreachable from each other.

The represented latency or bandwidth value is determined as follows:

- Represented latency = (Initiator to Target Proximity Domain matrix entry value * Entry Base Unit) picoseconds.
- Represented bandwidth = (Initiator to Target Proximity Domain matrix entry value * Entry Base Unit) MB/s.

The following examples show how to report latency and throughput values:

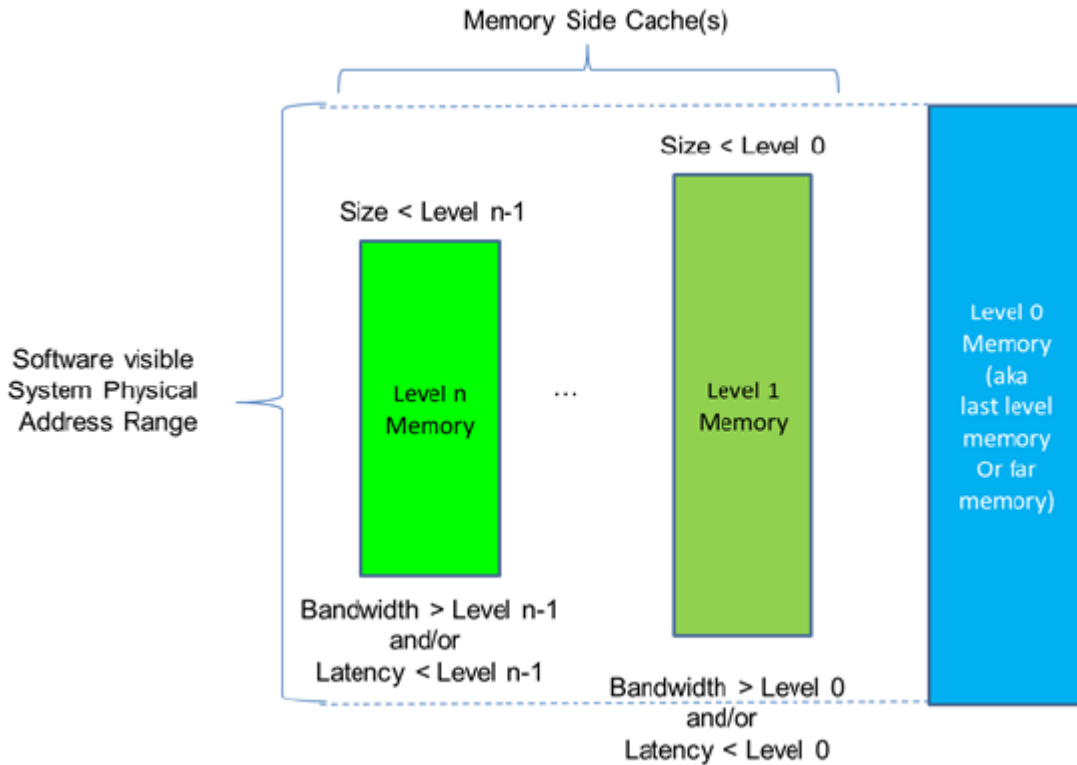

Fig. 5.11: Memory Side Cache Example

- If the “Entry Base Unit” is 1 for latency and the matrix entry has the value of 10, the latency is 10 picoseconds.
- If the “Entry Base Unit” is 1000 for latency and the matrix entry has the value of 100, the latency is 100 nanoseconds.
- If the “Entry Base Unit” is 1 for BW and the matrix entry has the value of 10, the BW is 10 MB/s.
- If the “Entry Base Unit” is 1024 for BW and the matrix entry has the value of 100, the BW is 100 GB/s.

Note: The lowest latency number represents best performance and the highest bandwidth number represents best performance. The latency and bandwidth numbers represented in this structure correspond to specification rated latency and bandwidth for the platform. The represented latency is determined by aggregating the specification rated latencies of the memory device and the interconnects from initiator to target. The represented bandwidth is determined by the lowest bandwidth among the specification rated bandwidth of the memory device and the interconnects from the initiator to target.

Multiple table entries may be present, based on qualifying parameters, like minimum transfer size, etc. They may be ordered starting from most- to least-optimal performance. Unless specified otherwise in the table, the reported numbers assume naturally aligned data and sequential access transfers. The platform should declare “Minimum transfer size” based on distinct, software observable boundaries for latency or bandwidth, as appropriate for the platform architecture.

Table 5.148: System Locality Latency and Bandwidth Information Structure

Field	Byte Length	Byte Offset	Description
Type	2	0	1 - System Locality Latency and Bandwidth Information Structure
Reserved	2	2	Reserved
Length	4	4	Length in bytes for entire structure.
Flags	1	8	<p>Bits [3:0] Memory hierarchy: 0x00 - Memory: If the memory side cache is not present, this structure represents the memory performance. If memory side cache is present, this structure represents the memory performance when no hits occur in any of the memory side caches associated with the memory. 0x01 - 1st level memory side cache 0x02 - 2nd level memory side cache 0x03 - 3rd level memory side cache</p> <p>Bits [5:4] Access attributes: 0x10 – minimum transfer size to achieve values 0x20 – non-sequential transfers</p> <p>Bits [7:6] Reserved</p>
Data Type	1	9	<p>Type of data represented by this structure instance: If Memory Hierarchy = 0: - 0 - Access Latency (if read and write latencies are same) - 1 - Read Latency - 2 - Write Latency - 3 - Access Bandwidth (if read and write bandwidth are same) - 4 - Read Bandwidth - 5 - Write Bandwidth</p> <p>If Memory Hierarchy = 1, 2, or 3: - 0 - Access Hit Latency (if read hit and write hit latencies are same) - 1 - Read Hit Latency - 2 - Write Hit Latency - 3 - Access Hit Bandwidth (if read hit and write hit latency are same) - 4 - Read Hit Bandwidth - 5 - Write Hit Bandwidth</p> <p>Other values are reserved.</p>

continues on next page

Table 5.148 – continued from previous page

Field	Byte Length	Byte Offset	Description
MinTransferSize	1	10	Transfer size defined as a 5-biased power of 2 exponent, when the bandwidth/latency value is achieved. The values are as follows: 0 – byte-aligned (any alignment) 1 – 64 Bytes 2 – 128 Bytes 3 – 256 Bytes ... 7 – 4096 Bytes 8 - 8192 Bytes ... 11 – 64KiByte ...
Reserved	1	11	Reserved
Number of Initiator Proximity Domains (s)	4	12	Indicates total number of Proximity Domains that can initiate memory access requests to other proximity domains. This is typically the processor or I/O proximity domains.
Number of Target Proximity Domains (t)	4	16	Indicates total number of Proximity Domains that can act as target. This is typically the Memory Proximity Domains.
Reserved	4	20	Reserved
Entry Base Unit	8	24	Base unit for Matrix Entry Values (latency or bandwidth). Base unit for latency in picoseconds. Base unit for bandwidth in megabytes per second (MB/s). This field shall be non-zero.
Initiator Proximity Domain List[0]	4	32	
Initiator Proximity Domain List[1]	4		
...			
Initiator Proximity Domain List[s-1]	4		
Target Proximity Domain List[0]	4	32 + 4 x s	
Target Proximity Domain List[1]	4		
...			
Target Proximity Domain List[t-1]	4		
Latency / bandwidth values			Total Number Entry shall be equal to Number of Initiator Proximity Domains * Number of Target Proximity Domains
Entry[0][0]	2	32 + 4 x s + 4 x t	Matrix entry (Initiator Proximity Domain List[0], Target Proximity Domain List[0])
Entry[0][1]	2		Matrix entry (Initiator Proximity Domain List[0], Target Proximity Domain List[1])
...			

continues on next page

Table 5.148 – continued from previous page

Field	Byte Length	Byte Offset	Description
Entry[0][Number of Target Proximity Domains - 1]	2		Matrix entry (Initiator Proximity Domain List[0], Target Proximity Domain List[t-1])
Entry[1][0]	2		Matrix entry (Initiator Proximity Domain List[1], Target Proximity Domain List[0])
Entry[1][1]	2		Matrix entry (Initiator Proximity Domain List[1], Target Proximity Domain List[1])
...			
Entry[1][Number of Target Proximity Domains - 1]			Matrix entry (Initiator Proximity Domain List[1], Target Proximity Domain List[t-1])
...			
Entry[Number of Initiator Proximity Domains - 1][Number of Target Proximity Domains - 1]	2		Matrix entry (Initiator Proximity Domain List[s-1], Target Proximity Domain List[t-1])

Implementation notes:

The Flag field in this table allows read latency, write latency, read bandwidth and write bandwidth as well as Memory Hierarchy levels, minimum transfer size and access attributes. Hence this structure could be repeated several times, to express all the appropriate combinations of Memory Hierarchy levels, memory and transfer attributes expressed for each level. If multiple structures are present, they may be ordered starting from most- to least-optimal performance. Unless specified otherwise in the table, the reported numbers assume naturally aligned data and sequential access transfers.

If either latency or bandwidth information is being presented in the HMAT, it is required to be complete with respect to initiator-target pair entries. For example, if read latencies are being included in the SLLBI, then read latencies for all initiator-target pairs must be present. If some pairs are incalculable, then the read latency dataset must be omitted entirely. It is acceptable to provide only a subset of the possible datasets. For example, it is acceptable to provide read latencies but omit write latencies. This provides OSPM a complete picture for at least one set of attributes, and it has the choice of keeping that data or discarding it.

The platform should declare “Minimum transfer size” based on distinct, software-observable boundaries for latency or bandwidth, as appropriate for the platform architecture.

If both SLIT table and the HMAT table with the memory latency information are present, the OSPM should attempt to use the data in the HMAT rather than the data in the SLIT.

5.2.28.5 Memory Side Cache Information Structure

System memory hierarchy could be constructed to have a large size of low performance far memory and smaller size of high performance near memory. The Memory Side Cache Information Structure describes memory side cache information for a given memory domain. The software could use this information to effectively place the data in memory to maximize the performance of the system memory that use the memory side cache.

Table 5.149: Memory Side Cache Information Structure

Field	Byte Length	Byte Offset	Description
Type	2	0	2 - Memory Side Cache Information Structure
Reserved	2	2	
Length	4	4	Length in bytes for entire structure.
Proximity Domain for the Memory	4	8	Integer that represents the memory proximity domain to which the memory side cache information applies. This number shall match the corresponding entry in the SRAT table's Memory Affinity Structure
Reserved	4	12	
Memory Side Cache Size	8	16	Size of memory side cache in bytes for the above memory proximity domain.
Cache Attributes	4	24	<p>Bits [3:0] - Total Cache Levels for this Memory Proximity Domain:</p> <ul style="list-style-type: none"> - 0 - None - 1 - One level cache - 2 - Two level cache - 3 - Three level cache - Other values reserved <p>Bits [7:4] - Cache Level described in this structure:</p> <ul style="list-style-type: none"> - 0 - None - 1 - One level cache - 2 - Two level cache - 3 - Three level cache - Other values reserved <p>Bits [11:8] - Cache Associativity:</p> <ul style="list-style-type: none"> - 0 - None - 1 - Direct Mapped - 2 - Complex Cache Indexing (implementation specific) - Other values reserved <p>Bits [15:12] - Write Policy</p> <ul style="list-style-type: none"> - 0 - None - 1 - Write Back (WB) - 2 - Write Through (WT) - Other values reserved <p>Bits [31:16] - Cache Line size in bytes. Number of bytes accessed from next cache level on cache miss.</p>
Reserved	2	28	
Number of SMBIOS handles (n)	2	30	Number of SMBIOS handles that contributes to the memory side cache physical devices.
SMBIOS Handles	2xn	32	Refers to corresponding SMBIOS Type-17 Handles Structure that contains Physical Memory Component related information

Implementation Note: A proximity domain should contain only one set of memory attributes. If memory attributes differ, represent them in different proximity domains. If the Memory Side Cache Information Structure is present, the

System Locality Latency and Bandwidth Information Structure shall contain latency and bandwidth information for each memory side cache level.

5.2.29 Platform Debug Trigger Table (PDTT)

This section describes the format of the Platform Debug Trigger Table (PDTT) description table, which is an optional table that describes one or more PCC subspace identifiers that can be used to trigger/notify the platform specific debug facilities to capture non-architectural system state. This is intended as a standard mechanism for the OSPM to notify the platform of a fatal crash (e.g. kernel panic or bug check).

This table is intended for platforms that provide debug hardware facilities that can capture system info beyond the normal OS crash dump. This trigger could be used to capture platform specific state information (e.g. firmware state, on-chip hardware facilities, auxiliary controllers, etc.). This type of debug feature could be leveraged on mobile, client, and enterprise platforms.

Certain platforms may have multiple debug subsystems that must be triggered individually. This table accommodates such systems by allowing multiple triggers to be listed.

After triggering debug facilities, the CPU may continue to operate as expected so that the kernel may continue with crash processing/handling (e.g. possibly attempting to attach a debugger or proceed with a full crash dump prior to rebooting the system), depending on the value defined in Trigger order. Please refer to [Section 5.2.29.2](#) for more details.

After triggering debug facilities, the CPU must continue to operate as expected so that the kernel may continue with crash processing/handling (e.g. possibly attempting to attach a debugger or proceed with a full crash dump prior to rebooting the system).

On some platforms, the debug trigger may put some hardware components/peripherals into a frozen non-operational state, and so the debug trigger is not recommended to be used during normal run-time operation.

Other platforms may allow the debug trigger for capture system state to debug run-time behavioral issues (e.g. system performance and power issues), specified by the “Run-time” flag field in [Table 5.151](#).

When multiple triggers exist, the triggers within each of the two groups, defined by trigger order, will be executed in order. OSPM may need to wait for PCC completion before executing next trigger based on the “Wait for Completion” flag field in [Table 5.151](#).

Note: The mechanism by which this system debug state information is retrieved by the user is platform and vendor specific. This will most likely will require special tools and privileges in order to access and parse the platform debug information captured by this trigger.

Table 5.150: PDTT Structure

Field	Byte Length	Byte Offset	Description
Signature	4	0	'PDTT'
Length	4	4	Length in bytes of the entire Platform Debug Trigger Table
Revision	1	8	0
Checksum	1	9	Entire table must sum to zero.
OEM ID	6	10	OEM ID
OEM Table ID	8	16	The table ID is the manufacturer model ID.
OEM Revision	4	24	OEM revision for supplied OEM Table ID.
Creator ID	4	28	Vendor ID of utility that created the table.
Creator Revision	4	32	Revision of utility that created the table.

continues on next page

Table 5.150 – continued from previous page

Field	Byte Length	Byte Offset	Description
Trigger Count	1	36	Number of PDTT Platform Communication Channel Identifiers
Reserved	3	37	Must be zero
Trigger Identifier Array Offset	4	40	Offset to the “PDTT Platform Communication Channel Identifiers[]” Array
PDTT Platform Communication Channel Identifiers []	—	Trigger Identifier Array Offset	Array of PDTT Platform Communication Channel Identifiers to notify various platform debug facilities. This identifier selects the PCC subspace index that must be listed in the PCCT. It also describes per trigger flags. Each Identifier is 2 bytes. Must provide a minimum of one identifier. See Table 5.151 below.

Table 5.151: PDTT Platform Communication Channel Identifier Structure

Field	Bit Length	Bit Offset	Description
PDTT PCC Sub Channel Identifier	8	0	PCC sub channel ID. Note: this must be an index listed in the PCCT
Run-time	1	8	0: Trigger must only be invoked in fatal crash scenarios. This debug trigger may put some hardware components/peripherals into a frozen non-operational state. 1: Trigger may be invoked at run-time as well as in fatal crash scenarios.
Wait for Completion	1	9	0: OSPM may initiate next trigger immediately 1: OSPM must wait for PCC complete prior to initiating the next trigger in the list
Trigger Order	1	10	Used in fatal crash scenarios: 0: OSPM must initiate trigger before kernel crash dump processing 1: OSPM must initiate trigger at the end of crash dump processing.
Reserved	5	11	Must be zero

5.2.29.1 PDTT PCC Sub Channel

The PDTT PCC Sub Channel Identifier value provided by the platform in this field is index in the PCCT table (as shown in the picture below). PCC Communications Subspace Structure for PDTT can use any type of PCC communication subspace. PCC Sub Channel entry in PCCT table identified by the PDTT PCC Sub Channel Identifier will have the information on type of PCC Sub channel definition associated with the debug trigger. The PDTT references its PCC Subspace in a given platform by this identifier, as shown in [Table 5.151](#).

[Section 5.2.29.1](#) below shows how the right PCC subspace entry associated with a debug trigger in PDTT can be found from the PCTT table.

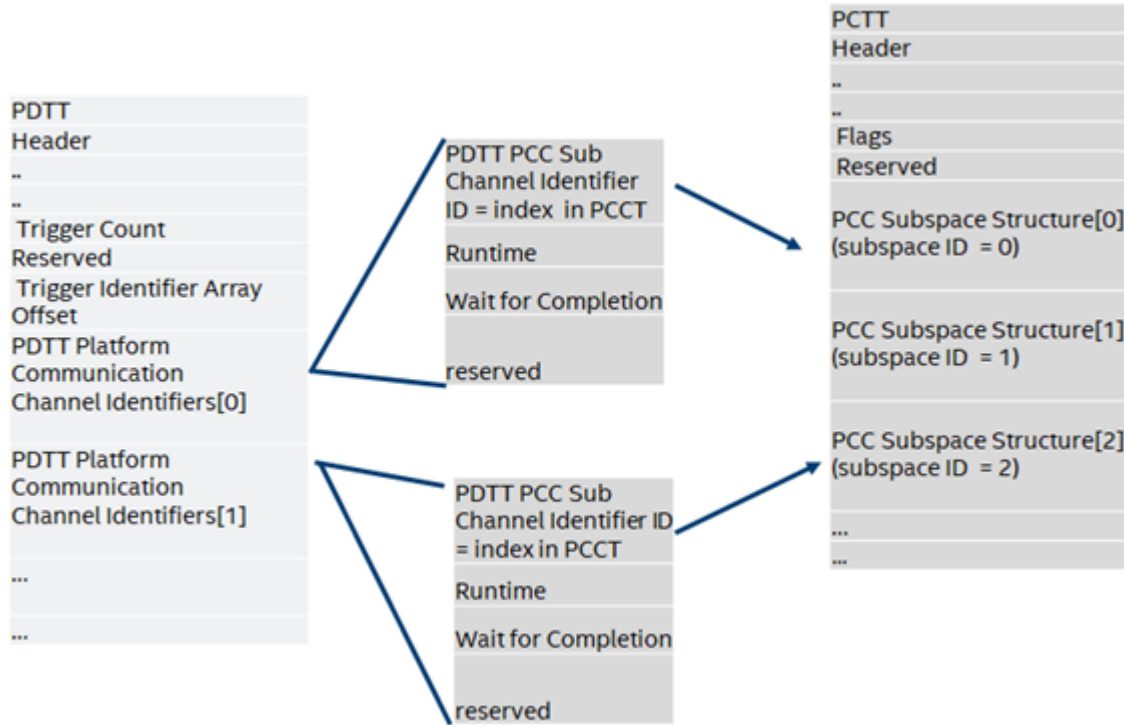

Fig. 5.12: Mapping a PDDT Debug Trigger Table Entry to a PCCT PCC Subspace

5.2.29.1.1 Using PCC registers

A platform debug trigger can choose to use any type of PCC subspace. The definition of the shared memory region for a debug trigger will follow the definition of shared memory region associated with the PCC subspace type used for the debug trigger. For example if a platform debug trigger chooses to use Generic PCC communication subspace (Type 0), then it will use the Generic Communication Channel shared memory region described in Section 14.2. OSPM will write PCC registers by filling in the register values in PCC sub channel space. If a platform debug trigger choose to use a PCC communication subchannel that uses a Generic Communication shared memory region then it will write the debug trigger command in the command field. See Table 5.151 for allowed debug commands. All other command values are reserved.

The platform can also use the PCC sub channel Type 5 for debug a trigger. In this case, OSPM will follow the PCC sub channel definition and write to the doorbell register to trigger a debug log. A platform debug trigger using PCC Communication sub channel Type 5 will use the shared memory region to share vendor-specific debug information.

The following table defines the Type-5 PCC channel shared memory region definition for debug trigger.

Table 5.152: Type 5 Platform Communication Channel Shared Memory

Field	Byte Length	Byte Offset	Description
Signature	4	0	The PCC signature. The signature of a subspace is computed by a bitwise-or of the value 0x50434300 with the subspace ID. For example, subspace 3 has the signature 0x50434303.
<i>Communication Subspace</i>			

continues on next page

Table 5.152 – continued from previous page

Field	Byte Length	Byte Offset	Description
Vendor specific space	—	4	Vendor specific area to share additional information between OSPM and platform. The length of the vendor specified area must be 4 bytes less than the Length field specified in the PCCT entry referring to this shared memory space.

Table 5.153: PCC Commands Codes used by Platform Debug Trigger Table

Command	Description
0x00	Execute Platform Debug Trigger (doorbell only - no command/response).
0x01	Execute Platform Debug Trigger (with vendor specific command in communication space).
0x01-0xFF	All other values are reserved.

Table 5.154: PDTT Platform Communication Channel

Field	Bit Length	Bit Off-set	Description
Signature	4	0	The PCC signature. The signature of a subspace is computed by a bitwise-or of the value 0x50434300 with the subspace ID. For example, subspace 3 has signature 0x50434303.
Command	2	4	PCC command field, see Section 14 and Table 5.153
Status	2	6	PCC status field (see Section 14)
Communication Space	—	—	—
Vendor-specific	Variable	8	Optional vendor specific command/response area written by OSPM - must be zero if not supported

5.2.29.2 PDTT PCC Trigger Order

The trigger order defines two categories for triggers

Trigger Order 0: Triggers are invoked by OSPM before executing its crash dump processing functions.

Trigger Order 1: Triggers are invoked by OSPM at the end of crash dump processing functions, typically after the kernel has processed crash dumps.

Capturing platform specific debug information from certain IPs would require intrusive mechanism which may limit kernel operations after the operations. Trigger order allows the platform to define such operations that will be invoked at the end of kernel operations by OSPM.

5.2.29.3 Example: OS Invoking Multiple Debug Triggers

To illustrate how these debug triggers are intended to be used by the OS, consider this example of a system with 4 independent debug triggers as shown in Fig. 5.13. These triggers are described to the OS via the PDTT example in Table 5.155.

Note: This example assumes no vendor specific communication is required, so only PCC command 0x0 is used.

When the OS encounters a fatal crash, prior to collecting a crash dump and rebooting the system, the OS may choose to invoke the debug triggers in the order listed in the PDTT. The addresses of the doorbell register and the PCC general communication space (if needed) are retrieved from the PCCT, depending on the PCC subspace type (see Table 14.4, Table 14.5, or Table 14.6).

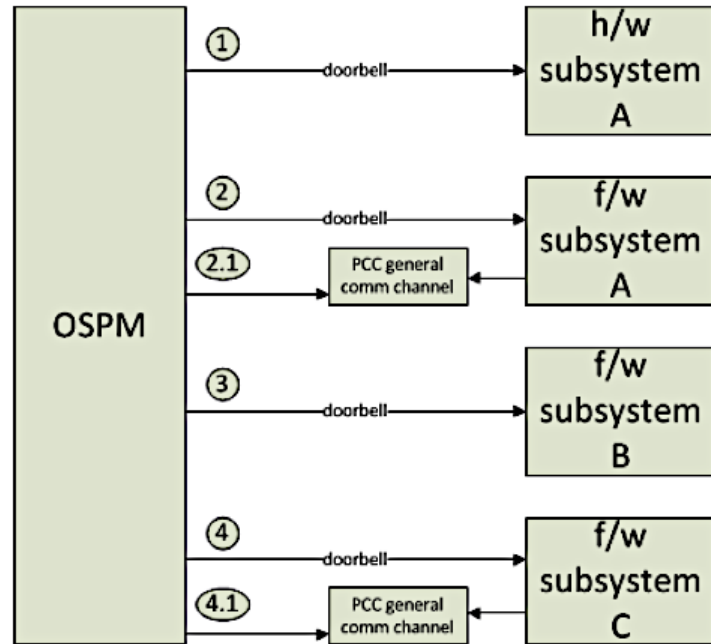

Fig. 5.13: Example: Platform with four debug triggers

Table 5.155: Example: Platform with 4 debug triggers

Field	Value	Notes
Signature	'PDTT'	
...
Trigger Count	4	Describing the 4 triggers illustrated in Fig. 5.13 above
Reserved	0	
Trigger Identifier Array Offset	44	
PDTT PCC Identifiers [0]	0x0004	[Bits 0:7] - 4 (channel subspace ID 4) [Bit 8] - 0 (Trigger may only be invoked in fatal crash scenarios) [Bit 9] - 0 (OSPM may initiate next trigger immediately)
PDTT PCC Identifiers [1]	0x0201	[Bits 0:7] - 1 (channel ID subspace 1) [Bit 8] - 0 (Trigger may only be invoked in fatal crash scenarios) [Bit 9] - 1 (OSPM must wait for PCC complete prior to initiating the next trigger in the list)
PDTT PCC Identifiers [2]	0x0002	[Bits 0:7] - 2 (channel ID subspace 2) [Bit 8] - 0 (Trigger may only be invoked in fatal crash scenarios) [Bit 9] - 0 (OSPM may initiate next trigger immediately)

continues on next page

Table 5.155 – continued from previous page

Field	Value	Notes
PDTT PCC Identifiers [3]	0x0203	[Bits 0:7] - 3 (channel ID subspace 3) [Bit 8] - 0 (Trigger may only be invoked in fatal crash scenarios) [Bit 9] - 1 (OSPM must wait for PCC complete prior to initiating the next trigger in the list)

Walking through the list of triggers in the PDTT, the OS may execute the following steps:

1. For Trigger 0, retrieves doorbell register address from PCCT per PCC subspace ID 4 and writes to it with appropriate write/preserve mask. Since OS does not need to wait for completion, OS does not need to send a PCC command and should ignore the PCC subspace base address
2. For Trigger 1, retrieves doorbell register address and PCC subspace address from PCCT per PCC subspace ID 1. Since OS must wait for completion, OS must write PCC command (0x0) and write to the doorbell register per section 14 and poll for the completion bit.
3. For Trigger 2, , retrieves doorbell register address from PCCT per PCC subspace ID 2 and writes to it with appropriate write/preserve mask. Since OS does not need to wait for completion, OS does not need to send a PCC command and should ignore the PCC subspace base address
4. For Trigger 3, retrieves doorbell register address and PCC subspace address from PCCT per PCC subspace ID 3. Since OS must wait for completion, OS must write PCC command (0x0) and write to the doorbell register per section 14 and poll for the completion bit.

Note: When wait for completion is necessary, the OS must poll bit zero (completion bit) of the status field of that PCC channel (see Table 14.6 and the Generic Communications Channel Shared Memory Region).

5.2.30 Processor Properties Topology Table (PPTT)

This optional table is used to describe the topological structure of processors controlled by the OSPM, and their shared resources, such as caches. The table can also describe additional information such as which nodes in the processor topology constitute a physical package. The structure of PPTT is described in Table 5.156 .

Table 5.156: Processor Properties Topology Table

Field	Byte Length	Byte Offset	Description
Header			
- Signature	4	0	'PPTT' Processor Properties Topology Table
- Length	4	4	Length of entire PPTT table in bytes
- Revision	1	8	3
- Checksum	1	9	The entire table must sum to zero.
- OEMID	6	10	OEM ID.
- OEM Table ID	8	16	OEM revision of table for supplied OEM Table ID
- OEM Revision	4	24	OEM revision of the PPTT for the supplied OEM Table ID.
- Creator ID	4	28	Vendor ID of utility that created the table
- Creator Revision	4	32	Revision of utility that created the table
Body			

continues on next page

Table 5.156 – continued from previous page

Field	Byte Length	Byte Offset	Description
• Processor topology structure[N]	—	36	List of processor topology structures

Note: Processor topology structures are described in the following sections.

5.2.30.1 Processor hierarchy node structure (Type 0)

The processor hierarchy node structure is described in Table 5.157 . This structure can be used to describe a single processor or a group. To describe topological relationships, each processor hierarchy node structure can point to a parent processor hierarchy node structure. This allows representing tree like topology structures. Multiple trees may be described, covering for example multiple packages. For the root of a tree, the parent pointer should be 0.

If PPTT is present, one instance of this structure must be present for every individual processor presented through the MADT interrupt controller structures. In addition, an individual entry must be present for every instance of a group of processors that shares a common resource described in the PPTT. Resources are described in other PPTT structures such as Type 1 cache structures. Each physical package in the system must also be represented by a processor node structure.

Each processor node includes a list of resources that are private to that node. Resources are described in other PPTT structures such as Type 1 cache structures. The processor node’s private resource list includes a reference to each of the structures that represent private resources to a given processor node. For compactness, separate instances of an identical resource can be represented with a single structure that is listed as a resource of multiple processor nodes.

For example, is expected that in the common case all processors will have identical L1 caches. For these platforms a single L1 cache structure could be listed by all processors, as shown in the following figure.

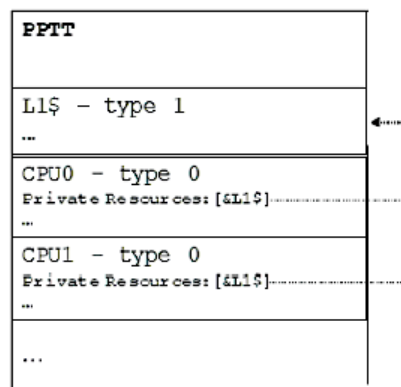

Fig. 5.14: L1 Cache Structure

Note: though less space efficient, it is also acceptable to declare a node for each instance of a resource. In the example above, it would be legal to declare an L1 for each processor.

Note: Compaction of identical resources must be avoided if an implementation requires any resource instance to be referenced uniquely. For example, in the above example, the L1 resource of each processor must be declared using a dedicated structure to permit unique references to it.

Table 5.157: Processor Hierarchy Node Structure

Field	Byte Length	Byte Offset	Description
Type	1	0	0 - processor structure
Length	1	1	Length of the local processor structure in bytes
Reserved	2	2	Must be zero
Flags	4	4	See Processor Structure Flags.
Parent	4	8	Reference to parent processor hierarchy node structure. The reference is encoded as the difference between the start of the PPTT table and the start of the parent processor structure entry. A value of zero must be used where a node has no parent.
ACPI Processor ID	4	12	If the processor structure represents an actual processor, this field must match the value of ACPI processor ID field in the processor's entry in the MADT. If the processor structure represents a group of associated processors, the structure might match a processor container in the name space. In that case this entry will match the value of the <code>_UID</code> method of the associated processor container. Where there is a match it must be represented. The flags field, described in <i>Processor Structure Flags</i> , includes a bit to describe whether the ACPI processor ID is valid.
Number of private resources	4	16	Number of resource structure references in Private Resources (below)
Private resources[N]	N*4	20	Each resource is a reference to another PPTT structure. The structure referred to must not be a processor hierarchy node. Each resource structure pointed to represents resources that are private the processor hierarchy node. For example, for cache resources, the cache type structure represents caches that are private to the instance of processor topology represented by this processor hierarchy node structure. The references are encoded as the difference between the start of the PPTT table and the start of the resource structure entry.

Processor Structure Flags are described in the following table.

Table 5.158: Processor Structure Flags

Field	Bit Length	Bit Offset	Description
Physical package	1	0	Set to 1 if this node of the processor topology represents the boundary of a physical package, whether socketed or surface mounted. Set to 0 if this instance of the processor topology does not represent the boundary of a physical package. Each valid processor must belong to exactly one package. That is, the leaf must itself be a physical package or have an ancestor marked as a physical package.

continues on next page

Table 5.158 – continued from previous page

Field	Bit Length	Bit Off-set	Description
ACPI Processor ID valid	1	1	For non-leaf entries in the processor topology, the ACPI Processor ID entry can relate to a Processor container in the namespace. The processor container will have a matching ID value returned through the <code>_UID</code> method. As not every processor hierarchy node structure in PPTT may have a matching processor container, this flag indicates whether the ACPI processor ID points to valid entry. Where a valid entry is possible the ACPI Processor ID and <code>_UID</code> method are mandatory. For leaf entries in PPTT that represent processors listed in MADT, the ACPI Processor ID must always be provided and this flag must be set to 1.
Processor is a Thread	1	2	For leaf entries: must be set to 1 if the processing element representing this processor shares functional units with sibling nodes. For non-leaf entries: must be set to 0.
Node is a Leaf	1	3	Must be set to 1 if node is a leaf in the processor hierarchy. Else must be set to 0.
Identical Implementation	1	4	A value of 1 indicates that all children processors share an identical implementation revision. This field should be ignored on leaf nodes by the OSPM. Note: this implies an identical processor version and identical implementation revision, not just a matching architecture revision.
Reserved	27	5	Must be zero

Note: Threads sharing a core must be grouped under a unique Processor hierarchy node structure for each group of threads.

Note: Processors may be marked as disabled in the MADT. In this case, the corresponding processor hierarchy node structures in PPTT should be considered as disabled. Additionally, all processor hierarchy node structures representing a group of processors with all child processors disabled should be considered as being disabled. All resources attached to disabled processor hierarchy node structures in PPTT should also be considered disabled.

5.2.30.2 Cache Type Structure - Type 1

The cache type structure is described in [Table 5.159](#). The cache type structure can be used to represent a set of caches that are private to a particular processor hierarchy node structure, that is, to a particular node in the processor topology tree. The set of caches is described as a NULL, or zero, terminated linked list. Only the head of the list needs to be listed as a resource by a processor node (and counted toward Number of Private Resources), as the cache node itself contains a link to the next level of cache.

Cache type structures are optional, and can be used to complement or replace cache discovery mechanisms provided by the processor architecture. For example, some processor architectures describe individual cache properties, but do not provide ways of discovering which processors share a particular cache. When cache structures are provided, all processor caches must be described in a cache type structure.

Each cache type structure includes a reference to the cache type structure that represents the next level cache. The level in this context must relate to the CPU architecture's definition of cache level. The list must include all caches that are private to a processor hierarchy node. It is not permissible to skip levels. That is, a cache node included in a

given hierarchy processor node level must not point to a cache structure referred to by a processor node in a different level of the hierarchy.

For example, if a node represents a CPU that has a private L1 and private L2 cache, the list would contain both caches (L1->L2->0). If on the other hand the L2 cache was shared, the list would just include the L1 (L1->0), and a parent processor topology node, to all processors that share the L2, would contain the cache type structure that represents the shared L2.

Processors, or higher level nodes within the hierarchy, with separate instruction and data caches must describe the instruction and data caches with separate linked lists of cache type structures both listed as private resources of the relevant processor hierarchy node structure. If the separate instruction and data caches are unified at a higher level of cache then the linked lists should converge.

Consider the example shown in the following figure.

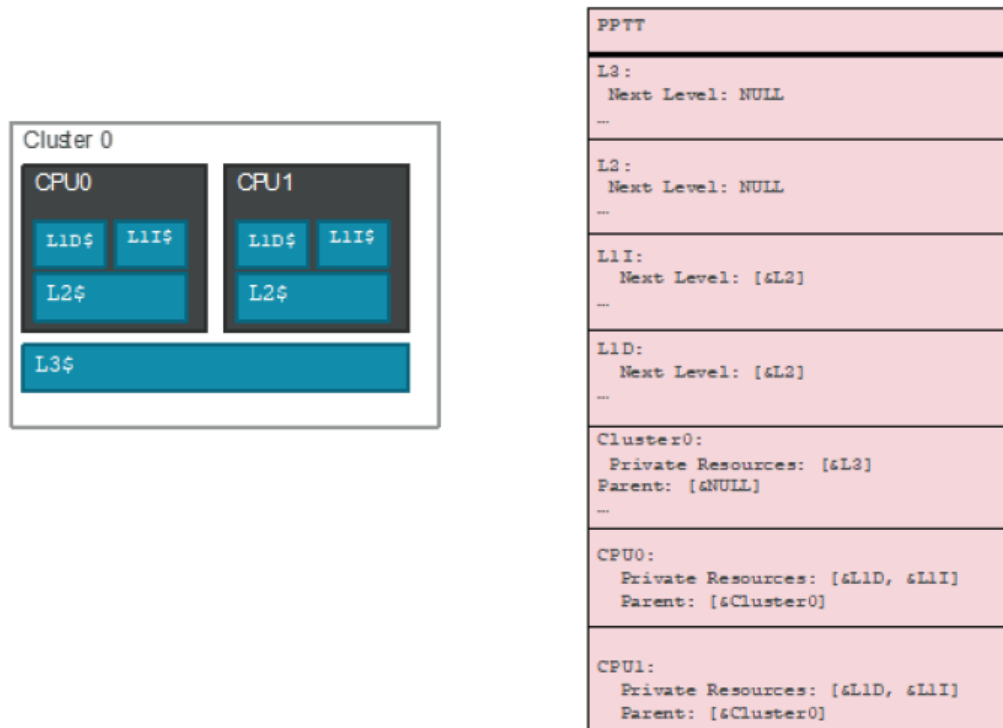

Fig. 5.15: Cache Type Structure - Type 1 Example

In this Type 1 example:

- Each processor has private L1 data, L1 instruction and L2 caches. The two processors are contained in a cluster which provides an L3 cache.
- Each processor’s hierarchy node has two separate cache type structures as private resources for L1I and L1D
- Both the L1I and L1D cache structures point to the L2 cache structure as their next level of cache
- L2 cache type structure terminates the linked list of the CPU’s caches. The resulting list denotes all private caches at the processor level
- Both processor nodes have their parent pointer pointing to node that represents the cluster.
- The cluster node includes the L3 cache as it’s private resource. The L3 node in turn has no next level of cache.

An entry in the list indicates primarily that a cache exists at this node in the hierarchy. Where possible, cache properties should be discovered using processor architectural mechanisms, but the cache type structure may also provide the properties of the cache. A flag is provided to indicate whether properties provided in the table are valid, in which case the table content should be used in preference to processor architected discovery. On Arm-based systems, all cache properties must be provided in the table.

Table 5.159: Cache Type Structure

Field	Byte Length	Byte Offset	Description
Type	1	0	1 - Cache type structure
Length	1	1	28
Reserved	2	2	Must be zero
Flags	4	4	See <i>Cache Structure Flags</i> .
Next Level of Cache	4	8	Reference to next level of cache that is private to the processor topology instance. The reference is encoded as the difference between the start of the PPTT table and the start of the cache type structure entry. This value will be zero if this entry represents the last cache level appropriate to the the processor hierarchy node structures using this entry.
Size	4	12	Size of the cache in bytes.
Number of sets	4	16	Number of sets in the cache
Associativity	1	20	Integer number of ways.
Attributes	1	21	Bits 1:0: Allocation type: 0x0 - Read allocate 0x1 - Write allocate 0x2 or 0x03 indicate Read and Write allocate Bits:3:2: Cache type: 0x0 Data 0x1 Instruction 0x2 or 0x3 Indicate a unified cache Bits 4: Write policy: 0x0 Write back 0x1 Write through Bits:7:5 Reserved must be zero.
Line size	2	22	Line size in bytes

continues on next page

Table 5.159 – continued from previous page

Field	Byte Length	Byte Offset	Description
Cache ID	4	24	Unique, non-zero identifier for this cache. If Cache ID is valid as indicated by the Flags field, then this structure defines a unique cache in the system. A Cache ID value of 0 indicates a NULL identifier that is not valid.

The cache type structure flags are described in the following table.

Table 5.160: Cache Structure Flags

Field	Bit Length	Bit Offset	Description
Size property valid	1	0	Set to 1 if the size properties described is valid. A value of 0 indicates that, where possible, processor architecture specific discovery mechanisms should be used to ascertain the value of this property.
Number of sets valid	1	1	Set to 1 if the number of sets property described is valid. A value of 0 indicates that, where possible, processor architecture specific discovery mechanisms should be used to ascertain the value of this property.
Associativity valid	1	2	Set to 1 if the associativity property described is valid. A value of 0 indicates that, where possible, processor architecture specific discovery mechanisms should be used to ascertain the value of this property.
Allocation type valid	1	3	Set to 1 if the allocation type attribute described is valid. A value of 0 indicates that, where possible, processor architecture specific discovery mechanisms should be used to ascertain the value of this attribute.
Cache type valid	1	4	Set to 1 if the cache type attribute described is valid. A value of 0 indicates that, where possible, processor architecture specific discovery mechanisms should be used to ascertain the value of this attribute.
Write policy valid	1	5	Set to 1 if the write policy attribute described is valid. A value of 0 indicates that, where possible, processor architecture specific discovery mechanisms should be used to ascertain the value of this attribute.
Line size valid	1	6	Set to 1 if the line size property described is valid. A value of 0 indicates that, where possible, processor architecture specific discovery mechanisms should be used to ascertain the value of this property.
Cache ID Valid	1	7	Set to 1 if the Cache ID property described is valid. A value of 0 indicates that, where possible, processor architecture specific discovery mechanisms should be used to ascertain the value of this property.
<i>Reserved</i>	24	8	Must be zero

5.2.31 Platform Health Assessment Table (PHAT)

This section describes the format of the Platform Health Assessment Table (PHAT), which provides a means by which a platform can expose an extensible set of platform health related telemetry that may be useful for software running within the constraints of an operating system. These elements are typically going to encompass things that are likely otherwise not enumerable during the OS runtime phase of operations, such as version of pre-OS components, or health status of firmware drivers that were executed by the platform prior to launch of the OS. It is not expected that the OSPM would act on the data being exposed.

Table 5.161: Platform Health Assessment Table (PHAT) Format

Field	Byte Length	Byte Offset	Description
Header			
- Signature	4	0	PHAT Signature for the Platform Health Assessment Table.
- Length	4	4	The length of the table, in bytes, of the entire PHAT
- Revision	1	8	The revision of the structure corresponding to the signature field for this table. For the PHAT conforming to this revision of the specification, the revision is 1.
- Checksum	1	9	The entire table, including the checksum field, must add to zero to be considered valid.
- OEMID	6	10	An OEM-supplied string that identifies the OEM.
- OEM Table ID	8	16	An OEM-supplied string that the OEM uses to identify this particular data table
- OEM Revision	4	24	OEM-supplied revision number.
- Creator ID	4	28	The Vendor ID of the utility that created this table.
- Creator Revision	4	32	The revision of the utility that created this table.
Platform Telemetry Records	–	36	The set of Platform Telemetry Records

5.2.31.1 Platform Health Assessment Record Format

A platform health assessment record is comprised of a sub-header including a record type and length, and a set of data. The format of the record layout is specific to the record type. In this manner, records are only as large as needed to contain the specific type of data to be conveyed.

Table 5.162: Platform Health Assessment Record Format

Field	Byte Length	Byte Offset	Description
Platform Health Assessment Record Type	2	0	This value depicts the format and contents of the platform health assessment record.
Record Length	2	2	This value depicts the length of the platform health assessment record, in bytes.
Revision	1	4	This value is updated if the format of the record type is extended. Any changes to a platform health assessment record layout must be backwards compatible in that all previously defined fields must be maintained if still applicable, but newly defined fields allow the length of the platform health record to be increased. Previously defined record fields must not be redefined, but are permitted to be deprecated.
Data	–	5	The content of this field is defined by the Platform Health Assessment Record Type definition.

5.2.31.2 Platform Health Assessment Record Type Format

The table below describes the various types of records contained within the PHAT, and their associated Platform Health Assessment Record Type. Note that unless otherwise specified, multiple platform telemetry records are permitted in the PHAT for a given type.

Table 5.163: Platform Health Assessment Record Type Format

Record Value	Type	Description
0x0000	Firmware Version Data Record	Pre-OS platform health assessment record containing version data for components within the platform firmware, option ROMs, and other pre-OS platform components.
0x0001	Firmware Health Data Record	Pre-OS platform health assessment record containing health-related information for pre-OS platform components.
0x0002 – 0x0FFF	<i>Reserved</i>	Reserved for ACPI specification usage.
0x1000 – 0x1FFF	<i>Reserved</i>	Reserved for Platform Vendor usage.
0x2000 – 0x2FFF	<i>Reserved</i>	Reserved for Hardware Vendor usage.
0x3000 – 0x3FFF	<i>Reserved</i>	Reserved for Platform Firmware Vendor usage.
0x4000 – 0x4FFF	<i>Reserved</i>	Reserved for future use.

5.2.31.3 Firmware Version Data Record Structure

A platform health assessment record which contains the version-related information associated with pre-OS components in the platform.

Table 5.164: PHAT Version Element

Field	Byte Length	Byte Offset	Description
Component ID	16	0	Unique GUID associated with this component.
Version Value	8	16	64-bit version value
Producer ID	4	24	The ACPI Vendor ID (e.g. ‘ABCD’): 0xFFFF – no ID defined 0x0000 – invalid value

Table 5.165: Firmware Version Data Record

Field	Byte Length	Byte Offset	Description
Platform Record Type	2	0	0 – Firmware Version Data Record
Record Length	2	2	12+28*RecordCount – This value depicts the length of the version data record, in bytes.
Revision	1	4	1 – Revision of this Firmware Version Data Record.
<i>Reserved</i>	3	5	Reserved
Record Count	4	8	PHAT Version Element Count

continues on next page

Table 5.165 – continued from previous page

Field	Byte Length	Byte Offset	Description
PHAT Version Element	Varies	12	Array of PHAT Version Elements. First entry is the original producer of the component, and if there's a subsequent entry, that means a second agent modified the original component in some way, and whichever the last entry is, that's the currently running instance of the component. This allows for IHV/IBV/OEM/others to establish a chain of data records associated with a given component.

5.2.31.4 Firmware Health Data Record Structure

A platform health assessment record which contains the health-related information associated with pre-OS components in the platform. This structure is intended to be used to identify the barebones state of a pre-OS component in a generic fashion. In addition, the Device Path can give standardized hints of where in the pre-OS the platform resides, whether it's a well-known hardware node (e.g. storage controller) or some other vendor specific location that may be hanging off another bus.

This structure also provides a means by which a platform could also expose device-specific data that goes beyond the simple healthy and not healthy statement.

Table 5.166: Firmware Health Data Record Structure

Field	Byte Length	Byte Offset	Description
Platform Record Type	2	0	1 – Firmware Health Data Record
Record Length	2	2	varies – This value depicts the length of the health data record, in bytes.
Revision	1	4	1 – Revision of this Firmware Health Data Record.
Reserved	2	5	Reserved
AmHealthy	1	7	Has the device encountered any issues? This allows any agent parsing this record to understand in whether or not the device is healthy without needing to parse the device-specific health data. Any device health state may expose device-specific data: 0= Errors found 1= No errors found 2= Unknown 3= Advisory – additional device-specific data exposed
DeviceSignature	16	8	The unique GUID associated with this device.
Device-specific Data Offset	4	24	Offset to the Device-specific Data from the start of this Data Record. If 0, then there is no device-specific data.
Device Path	Varies	28	The UEFI Device Path associated with the record producer. See the UEFI specification for the EFI_DEVICE_PATH_PROTOCOL definition.
Device-specific Data	Varies	Device-specific Data Offset	The health record associated with a particular device. Its definition is specific to the given device that produced this record.

5.2.31.5 Reset Reason Health Record

The Reset Reason Health Record defines a mechanism to describe the cause of the last system reset or boot. The record will be created as a Health Record in the PHAT table. This provides a standard way for system firmware to inform the operating system of the cause of the last reset. This includes both expected and unexpected events to support insights across a fleet of systems by way of collecting the reset reason records on each boot.



The record provides an optional vendor reason to capture the underlying state used to generate the reset reason (e.g. hardware registers) to support vendor specific details. The reset reason is intended to supplement existing fault reporting mechanisms on the platform (e.g. BERT tables, CPER) or in the operating system (e.g. event logs)

Table 5.167: **Reset Reason Health Record Header**

Field	Byte Length	Byte Offset	Description
Platform Record Type	2	0	1 - Firmware Health Data Record. Pre-OS platform health assessment record containing health-related information for pre-OS platform components.
Record Length	2	2	Varies - This value depicts the length of the health data record, in bytes.
Revision	1	4	1 - Revision of this Firmware Health Data Record.
<i>Reserved</i>	2	5	<i>Reserved</i>
AmHealthy	1	7	Has the device encountered any issues? This allows any agent parsing this record to understand in whether or not the device is healthy without needing to parse the device-specific health data. Any device health state may expose device-specific data: 0 = Errors found 1 = No errors found 2 = Unknown 3 = Advisory - additional device-specific data exposed The Reset Reason should set this value to '1' (no error) for expected resets/boots, and '0' (error) for unexpected conditions.

continues on next page

Table 5.167 – continued from previous page

DeviceSignature	16	8	<p>The unique GUID associated with this health record type.</p> <p>7a014ce2-f263-4b77-b88a-e6336b782c14</p> <p>{0x7a014ce2, 0xf263, 0x4b77, {0xb8, 0x8a, 0xe6, 0x33, 0x6b, 0x78, 0x2c, 0x14}}</p> <p>This GUID is normative for this record type and must not be changed.</p>
Device-specific Data Offset	4	24	<p>Offset to the Device-specific Data from the start of this Data Record.</p> <p>Offset = 0x0074</p>
Device Path	88	28	<p>The UEFI Device Path associated with the record producer. See the UEFI specification (https://uefi.org/specifications) for the EFI_DEVICE_PATH_PROTOCOL definition.</p> <p>VenHw(7A014CE2-F263-4B77-B88A-E6336B782C14)</p>
Device-specific Data	116	Varies	<p>The reset reason health record associated with this reset/boot event.</p>

Table 5.168: Reset Reason Health Record Structure

Field	Byte Length	Byte Offset	Description
Supported Sources	1	0	<p>This field indicates which sources are supported on the platform. A source that is unavailable may still provide insight into interpretation of the reset. For example, a reset due to an operating system fault without the operating system source supported may appear as a warm reset.</p> <p>[0]: Unknown source [1]: Hardware source [2]: Firmware source [3]: Software source [4]: Supervisor source [7:5]: Reserved</p>

continues on next page

Table 5.168 – continued from previous page

Source	1	1	<p>This field indicates the source of the reset. Only one bit should be set, or the field should be set to zero if unknown.</p> <p>[0]: Unknown source [1]: Hardware source [2]: Firmware source [3]: Software initiated reset [4]: Supervisor initiated reset [7:5]: Reserved</p> <p>A firmware device may include a baseboard management controller (BMC). A supervisor may include devices external to the system such as an uninterruptible power supply or a KVM over IP with power control.</p>
Sub Source	1	2	<p>The sub-source field allows for an optional categorization of the source field. It must be zero if a sub-source is not defined.</p> <p>Unknown Source [0]: Unknown</p> <p>Hardware Source [0]: Unknown</p> <p>Firmware Source [0]: Unknown</p> <p>Software Source 1: Operating System 2: Hypervisor</p> <p>Supervisor Source [0]: Unknown</p>

continues on next page

Table 5.168 – continued from previous page

Reason	1	3	<p>The reset reason represents the best explanation of the last system reset or boot. The implementation should choose the reason that best categorizes the last system reset or boot. The platform implementation may choose which value to use when multiple choices are possible, and should prefer a more specific reason over a generic reason and an error condition over a non-error condition. The reason field is used in conjunction with the Source fields to categorize and interpret the record.</p> <p>0: UNKNOWN The reset reason is unknown.</p> <p>Expected reset reasons</p> <p>1: COLD BOOT The system was successfully booted from an ‘off’ state (e.g. the user pressed the power button to boot).</p> <p>2: COLD RESET The system was successfully rebooted and performed a full cold reset.</p> <p>3: WARM RESET The system was successfully reset. (e.g. a user initiated reboot in the OS)</p> <p>4: UPDATE A system or software update was applied that required a reset.</p> <p>Unexpected reset reasons</p> <p>32: UNEXPECTED RESET An unexpected reset occurred. This may also include undocumented reasons that do not fit into another category. A more specific category should be preferred when possible.</p> <p>33: FAULT A hardware, firmware or software fault occurred (e.g. an uncorrectable machine check, a uncorrectable software fault).</p> <p>34: TIMEOUT A timeout occurred. (e.g. a hardware, firmware or software watchdog timeout).</p> <p>35: THERMAL A thermal limit was exceeded. (e.g. a hardware triggered reset due to proc hot)</p> <p>36: POWER LOSS The system unexpectedly loss power.</p> <p>37: POWER BUTTON The user or external actor reset the system via a power button press.</p>
--------	---	---	---

continues on next page

Table 5.168 – continued from previous page

Vendor Count	2	4	The number of Vendor Specific Reset Reason entries.
Vendor Specific Reset Reason Entry[n]	Varies	6	A series of Vendor Specific Reset Reason Entries.

The vendor portion of the record provides an optional means to store the underlying raw data that was interpreted to produce the reset reason. Storing the underlying data associated with a reset may allow for further analysis (e.g. an unexpected reset reason) and insight into the specifics of the reset.

Table 5.169: Reset Reason Health Record Vendor Data Entry

Field	Byte Length	Byte Offset	Description
Vendor Data ID	16	0	A vendor defined GUID that describes this entry type.
Length	2	16	The length of the vendor data entry.
Revision	2	18	Minor.Major Version Byte 0 (Minor) indicates that changes to the vendor-specific data are backwards compatible with the Vendor Data ID. Byte 1 (Major) indicates that changes to the data are not backwards compatible.
Data	Varies	20	Vendor-specific data payload.

5.2.32 Virtual I/O Translation (VIOT) Table

The Virtual I/O Translation (VIOT) Table describes the topology of para-virtual I/O translation devices (e.g., virtio-iommu in Linux) and the endpoints they manage. This is analogous to the vendor-specific IOMMU tables currently defined: the IORT for the ARM SMMU, the DMAR for Intel VT-d, and the IVRS for the AMD IOMMU. In this case, however, we are defining the topology connecting a hypervisor to a virtual machine through a para-virtualized IOMMU, instead a vendor-specific device. Since this para-virtualized IOMMU is a software component between the hypervisor and a virtual machine, the VIOT can be supported across multiple platforms; by defining the VIOT here, we help ensure consistency across those platforms since a para-virtualized IOMMU cannot be enumerated via any other mechanisms.

This table is optional. If the VIOT table is present, the OSPM should assume this functionality is available for use and must be configured properly.

5.2.32.1 Virtual I/O Translation (VIOT) Table Header

The VIOT table starts with a standard ACPI header.

Table 5.170: Virtual I/O Translation (VIOT) Table format

Field	Byte Length	Byte Offset	Description
Signature	4	0	“VIOT”, Virtual I/O Translation Table
Length	4	4	Length in bytes of the entire VIOT
Revision	1	8	1
Checksum	1	9	The entire table must sum to zero.
OEM ID	6	10	OEM Identifier
OEM Table ID	8	16	For the VIOT, the table ID is the manufacture model ID
OEM Revision	4	24	OEM revision of the VIOT for the supplied OEM Table ID
Creator ID	4	28	The vendor ID of the utility that created the table
Creator Revision	4	32	The revision of the utility that created the table
Node Count	2	36	Number of nodes defined in the table
Node Offset	2	38	Offset from the start of the table to the first node
<i>Reserved</i>	8	40	<i>Reserved, must be zero</i>
Node Structure[n]	—	48	A list of Node structures

After the *Creator Revision*, the remainder of the VIOT table is a list of *Node Count* nodes, each describing either endpoints or translation devices. The first Node Structure is located *Node Offset* bytes from the beginning of the table. Each node has a *Type* and *Length* field followed by a varying number of additional fields, defined by the *Type* of the node being described, defined below. The *Length* field defines the node’s length, and the following node is located *Length* bytes from the beginning of the current node. Nodes must be aligned on eight byte boundaries.

Each node identifies one or more devices using either their PCI Handle or their base MMIO (Memory-Mapped I/O) address. A PCI Handle is a PCI Segment number and a BDF (Bus-Device-Function) with the following layout:

- **Bits 15:8** Bus Number
- **Bits 7:3** Device Number
- **Bits 2:0** Function Number

This identifier corresponds to the one observed by the operating system when parsing the PCI configuration space for the first time after boot.

Endpoint nodes declare an *Output Node* that corresponds to the offset from the beginning of the table to the node describing the next translation device that manages these endpoints. They also declare one or more endpoint IDs that system software uses to identify endpoints when programming the translation device.

5.2.32.2 VIOT Node Structures

Each Node in the VIOT table can be one of the following types.

Table 5.171: VIOT Node Structure Types

Type	Description
0	<i>Reserved. Do Not Use.</i>
1	PCI Range Structure
2	MMIO Endpoint Structure
3	virtio-pci IOMMU Structure

continues on next page

Table 5.171 – continued from previous page

4	virtio-mmio IOMMU Structure
5-0xFF	<i>Reserved</i>

5.2.32.3 PCI Range Node Structure

This structure describes a range of PCI endpoints, identified by their structure and BDF number.

Table 5.172: PCI Range Node Structure format

Field	Byte Length	Byte Offset	Description
Type	1	0	1 – PCI Range
<i>Reserved</i>	1	1	<i>Reserved</i>
Length	2	2	Length of this node in bytes (24)
Endpoint Start	4	4	First endpoint ID
PCI Segment Start	2	8	First PCI Segment number in the range
PCI Segment End	2	10	Last PCI Segment number in the range
PCI BDF Start	2	12	First Bus-Device-Function number in the range
PCI BDF End	2	14	Last Bus-Device-Function number in the range
Output Node	2	16	Offset from the start of the table to the next translation element
<i>Reserved</i>	6	18	<i>Reserved, must be zero</i>

The node refers to a PCI endpoint if the endpoint’s segment number is in the range [Segment Start, Segment End] and its BDF number is in the range [BDF Start, BDF End]. The corresponding endpoint ID is obtained by combining segment and BDF:

$$\text{Endpoint ID} = ((\text{segment} - \text{Segment Start}) \ll 16) + \text{BDF} - \text{BDF Start} + \text{Endpoint Start}$$

5.2.32.4 Single MMIO Endpoint Node Structure

A single endpoint is identified by its base MMIO address.

Table 5.173: Single MMIO Endpoint Node Structure format

Field	Byte Length	Byte Offset	Description
Type	1	0	2 - MMIO Endpoint
<i>Reserved</i>	1	1	<i>Reserved, must be zero</i>
Length	2	2	Length of this node in bytes (24)
Endpoint ID	4	4	The endpoint ID
Base Address	8	8	Base MMIO address of the endpoint
Output Node	2	16	Offset from the start of the table to the next translation element
<i>Reserved</i>	6	18	<i>Reserved, must be zero</i>

5.2.32.5 virtio-iommu based on virtio-pci Node Structure

A virtio-iommu device can be based on the virtio-pci transport, and identified by the BDF of the virtio device.

Table 5.174: virtio-iommu based on virtio-pci Node Structure

Field	Byte Length	Byte Offset	Description
Type	1	0	3 - virtio-pci IOMMU
<i>Reserved</i>	1	1	<i>Reserved, must be zero</i>
Length	2	2	Length of this node in bytes (16)
PCI Segment	2	4	The PCI segment number of the virtio-iommu programming interface as returned by <code>_SEG</code> in the ACPI namespace
PCI BDF Number	2	6	Identifier for the PCI Device
<i>Reserved</i>	8	8	<i>Reserved, must be zero</i>

5.2.32.6 virtio-iommu based on virtio-mmioNode Structure

A virtio-iommu device can be based on the virtio-mmio transport, and identified by the base address of the virtio device. Like other virtio-iommu devices, properties of the virtio-iommu are described with an LNRO0005 element in the ACPI namespace.

Table 5.175: virtio-iommu based on virtio-mmio Node Structure format

Field	Byte Length	Byte Offset	Description
Type	1	0	3 - virtio-mmio IOMMU
<i>Reserved</i>	1	1	<i>Reserved, must be zero</i>
Length	2	2	Length of this node in bytes (16)
<i>Reserved</i>	4	4	<i>Reserved, must be zero</i>
Base Address	8	8	Base MMIO address for the device

5.2.33 Miscellaneous GUIDed Table Entries

This section describes a means by which a platform can expose data through a GUIDed entry through a single well-known MISC table signature. The MISC table and each GUIDed entry is defined sufficiently in this specification to allow for the discovery of the MISC table and walking the GUIDed entries that it may contain. The format of the data within each GUIDed entry is vendor specific and defined by the Entry GUID ID.

GUIDs in the MISC table shall meet the following expectations:

1. There is no requirement to register a GUID that's used in an MISC table entry.
2. Optionally, GUIDs in the MISC table can be registered using the same process as ACPI table signatures.

Table 5.176: Miscellaneous GUIDed Table Entries (MISC) Format

Field	Byte Length	Byte Offset	Description
Signature	4	0	“MISC” Signature for the GUIDed Table Entries.
Length	4	4	The length of the table, in bytes, of the entire MISC.

continues on next page

Table 5.176 – continued from previous page

Revision	1	8	The revision of the structure corresponding to the signature field for this table. For the Miscellaneous GUIDed Table Entries conforming to this revision of the specification, the revision is 1.
Checksum	1	9	The entire table, including the checksum field, must add to zero to be considered valid.
OEMID	6	10	An OEM-supplied string that identifies the OEM.
OEM Table ID	8	16	An OEM-supplied string that the OEM uses to identify this particular data table.
OEM Revision	4	24	An OEM-supplied revision number.
Creator ID	4	28	The Vendor ID of the utility that created this table.
Creator Revision	4	32	The revision of the utility that created this table.
GUIDed Entries	–	36	The set of one or more GUIDed Entries.

Table 5.177: GUIDed Entry Format

Field	Byte Length	Byte Offset	Description
Entry GUID ID	16	0	This value specifies the format and contents of the GUIDed entry.
Entry Length	4	16	This value specifies the length of the GUIDed entry, in bytes.
Revision	4	20	This value is updated every time the entry format specified by the given GUID ID is extended.
Producer ID	4	24	The ACPI Vendor ID (e.g. 'ABCD').
Data	–	28	The content of this field is defined by the Entry GUID ID.

5.2.34 CC Event Log ACPI Table

This section describes the format of the confidential computing (CC) event log ACPI table. A virtual firmware with CC capability may set up an ACPI table to pass the CC event log information. The event log created by the virtual firmware owner contains the hashes to reconstruct the CC measurement registers.

Table 5.178: CC Event Log ACPI Table

Field	Byte Length	Byte Offset	Description
Header			
Signature	4	0	'CCEL' Signature
- Length	4	4	Length, in bytes, of the entire table.
- Revision	1	8	1
- Checksum	1	9	Entire table must sum to zero.
- OEMID	6	10	Standard ACPI header
- OEM Table ID	8	16	Standard ACPI header
- OEM Revision	4	24	Standard ACPI header
- Creator ID	4	28	Standard ACPI header
- Creator Revision	4	32	Standard ACPI header

continues on next page

Table 5.178 – continued from previous page

CC Type	1	36	Confidential computing (CC) type. 0: Reserved 1: AMD SEV 2: Intel TDX 3~0xFF: Reserved
CC Subtype	1	37	Confidential computing (CC) type specific sub type.
<i>Reserved</i>	2	38	Reserved. Must be 0.
Log Area Minimum Length (LAML)	8	40	Identifies the minimum length (in bytes) of the system's pre-boot CC event log area.
Log Area Start Address (LASA)	8	48	Contains the 64-bit-physical address of the start of the system's pre-boot CC event log area in QWORD format. Note: The log area ranges from address LASA to LASA+(LAML-1).

5.2.35 Storage Volume Key Location Table

This section describes the format of the confidential computing (CC) storage volume key location ACPI table. In the CC environment, the storage volume will typically be an encrypted volume. In that case, the virtual firmware may need to support quote generation and attestation to be able to fetch a set of storage-volume key(s) from a remote-key server during boot and pass the key to the guest kernel. Typically, the key is stored in memory, and the information of the key is passed from virtual firmware via an ACPI table.

Table 5.179: Storage Volume Key Location Table

Field	Byte Length	Byte Offset	Description
Header			
Signature	4	0	'SKVL' Signature
- Length	4	4	Length, in bytes, of the entire table.
- Revision	1	8	1
- Checksum	1	9	Entire table must sum to zero.
- OEMID	6	10	Standard ACPI header
- OEM Table ID	8	16	Standard ACPI header
- OEM Revision	4	24	Standard ACPI header
- Creator ID	4	28	Standard ACPI header
- Creator Revision	4	32	Standard ACPI header
Key Count (C)	4	36	The count of key structure
Key Structure	16 * C	40	The key structure

Table 5.180: Storage Volume Key Structure

Field	Byte Length	Byte Offset	Description
Key Type	2	0	The type of the key. 0: the main storage volume key. 1~0xFFFF: reserved.

continues on next page

Table 5.180 – continued from previous page

Key Format	2	2	The format of the key. 0: raw binary. 1~0xFFFF: reserved.
Key Size	4	4	The size of the key in bytes.
Key Address	8	8	The guest-physical address (GPA) of the key. The address must be in ACPI-Reserved Memory.

5.3 ACPI Namespace

For all Definition Blocks, the system maintains a single hierarchical namespace that it uses to refer to objects. All Definition Blocks load into the same namespace. Although this allows one Definition Block to reference objects and data from another (thus enabling interaction), it also means that OEMs must take care to avoid any naming collisions. For the most part, since the name space is hierarchical, typically the bulk of a dynamic definition file will load into a different part of the hierarchy. The root of the name space and certain locations where interaction is being designed are the areas in which extra care must be taken.

A name collision in an attempt to load a Definition Block is considered fatal. The contents of the namespace changes only on a load operation.

The namespace is hierarchical in nature, with each name allowing a collection of names “below” it. The following naming conventions apply to all names:

- All names are a fixed 32 bits.
- The first byte of a name is inclusive of: ‘A’-‘Z’, ‘_’, (0x41-0x5A, 0x5F).
- The remaining three bytes of a name are inclusive of: ‘A’-‘Z’, ‘0’-‘9’, ‘_’, (0x41-0x5A, 0x30-0x39, 0x5F).
- By convention, when an ASL compiler pads a name shorter than 4 characters, it is done so with trailing underscores (‘_’). See the language definition for AML NameSeg in the ASL Reference chapter.
- Names beginning with ‘_’ are reserved by this specification. Definition Blocks can only use names beginning with ‘_’ as defined by this specification.
- A name preceded with ‘\’ causes the name to refer to the root of the namespace (‘\’ is not part of the 32-bit fixed-length name).
- A name preceded with ‘^’ causes the name to refer to the parent of the current namespace (‘^’ is not part of the 32-bit fixed-length name).

Except for names preceded with a ‘\’, the current namespace determines where in the namespace hierarchy a name being created goes and where a name being referenced is found. A name is located by finding the matching name in the current namespace, and then in the parent namespace. If the parent namespace does not contain the name, the search continues recursively upwards until either the name is found or the namespace does not have a parent (the root of the namespace). This indicates that the name is not found - unless the operation being performed is explicitly prepared for failure in name resolution, this is considered an error and may cause the system to stop working.

An attempt to access names in the parent of the root will result in the name not being found.

There are two types of namespace paths: an absolute namespace path (that is, one that starts with a ‘\’ prefix), and a relative namespace path (that is, one that is relative to the current namespace). The namespace search rules discussed above, only apply to single NameSeg paths, which is a relative namespace path. For those relative name paths that contain multiple NameSegs or Parent Prefixes, ‘^’, the search rules do not apply. If the search rules do not apply to a relative namespace path, the namespace object is looked up relative to the current namespace. For example:

```

ABCD //search rules apply
^ABCD //search rules do not apply
XYZ.ABCD //search rules do not apply
\\XYZ.ABCD //search rules do not apply
    
```

All name references use a 32-bit fixed-length name or use a Name Extension prefix to concatenate multiple 32-bit fixed-length name components together. This is useful for referring to the name of an object, such as a control method, that is not in the scope of the current namespace.

Namepaths are used primarily for two purposes:

- To reference an existing object. In this case, all NameSegs within the Namepath must already exist.
- To create a new object. For example:

```

Device (XYZ.ABCD) {...}
OperationRegion (\XYZ.ABCD, SystemMemory, 0, 0x200)
    
```

Each of these declarations is intended to create a new object with the name ABCD according the following rules:

- Object XYZ must already exist for the ABCD object to be created
- If XYZ does not exist, that will cause a fatal error

In general, it is only the final Nameseg that will be used as the name of the new object. If any other Nameseg along the Namepath does not exist, it is a fatal error. In this sense, the Namepath is similar to a file pathname in a filesystem consisting of some number of existing directories followed by a final filename.

The figure below shows a sample of the ACPI namespace after a Differentiated Definition Block has been loaded.

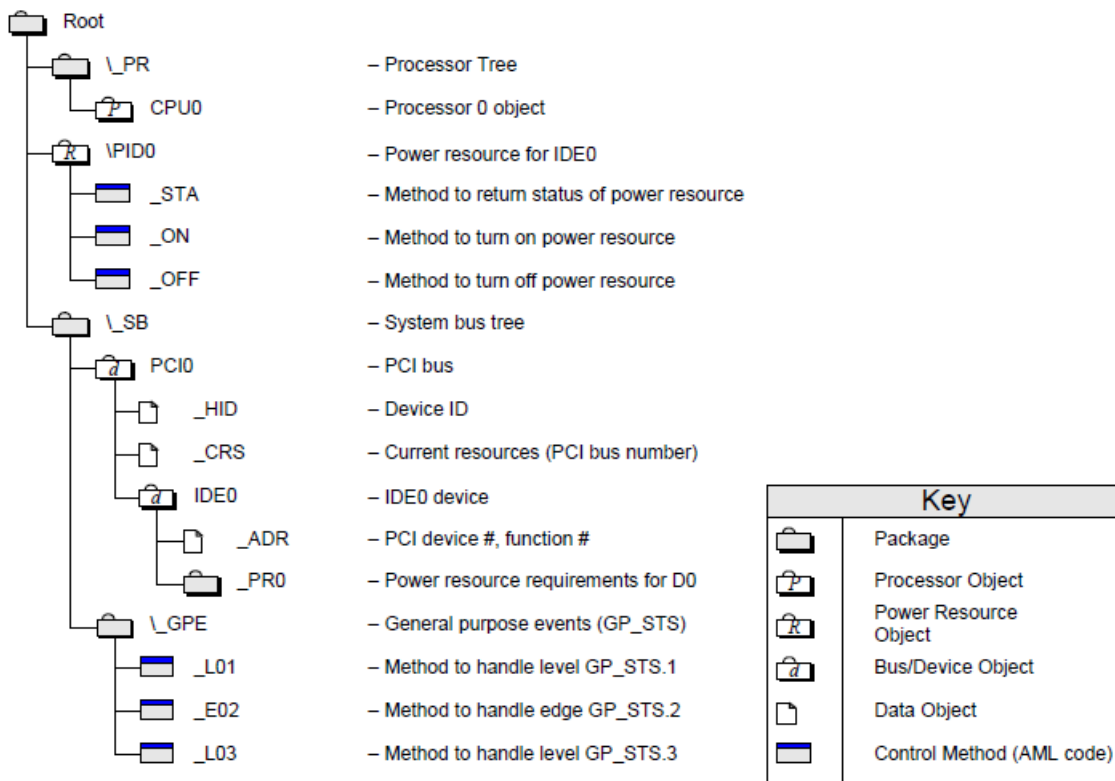

Fig. 5.16: Example ACPI NameSpace

Care must be taken when accessing namespace objects using a relative single segment name because of the namespace search rules. An attempt to access a relative object recurses toward the root until the object is found or the root is encountered. This can cause unintentional results. For example, using the namespace described in Figure 5.5, attempting to access a `_CRS` named object from within the `_SB_PCI0.IDE0` will have different results depending on if an absolute or relative path name is used. If an absolute pathname is specified (`_SB_PCI0.IDE0._CRS`) an error will result since the object does not exist. Access using a single segment name (`_CRS`) will actually access the `_SB_PCI0._CRS` object. Notice that the access will occur successfully with no errors.

5.3.1 Predefined Root Namespaces

The following namespaces are defined under the namespace root.

Table 5.181: Namespaces Defined Under the Namespace Root

Name	Description
<code>_GPE</code>	General events in GPE register block.
<code>_PR</code>	ACPI 1.0 Processor Namespace. ACPI 1.0 requires all Processor objects to be defined under this namespace. ACPI 2.0 and later allow Processor object definitions under the <code>_SB</code> namespace. Platforms may maintain the <code>_PR</code> namespace for compatibility with ACPI 1.0 operating systems, but it is otherwise deprecated. see the compatibility note in <i>Processor Local x2APIC Structure</i> . An ACPI-compatible namespace may define Processor objects in either the <code>_SB</code> or <code>_PR</code> scope but not both. For more information about defining Processor objects, see Processor Configuration and Control.
<code>_SB</code>	All Device/Bus Objects are defined under this namespace.
<code>_SI</code>	System indicator objects are defined under this namespace. For more information about defining system indicators, see <code>_SI</code> System Indicators.
<code>_TZ</code>	ACPI 1.0 Thermal Zone namespace. ACPI 1.0 requires all Thermal Zone objects to be defined under this namespace. Thermal Zone object definitions may now be defined under the <code>_SB</code> namespace. ACPI-compatible systems may maintain the <code>_TZ</code> namespace for compatibility with ACPI 1.0 operating systems. An ACPI-compatible namespace may define Thermal Zone objects in either the <code>_SB</code> or <code>_TZ</code> scope but not both. For more information about defining Thermal Zone objects, see Thermal Management.

5.3.2 Objects

All objects, except locals, have a global scope. Local data objects have a per-invocation scope and lifetime and are used to process the current invocation from beginning to end.

The contents of objects vary greatly. Nevertheless, most objects refer to data variables of any supported data type, a control method, or system software-provided functions.

Objects may contain a revision field. Successive ACPI specifications define object revisions so that they are backwards compatible with OSPM implementations that support previous specifications / object revisions. New object fields are added at the end of previous object definitions. OSPM interprets objects according to the revision number it supports including all earlier revisions. As such, OSPM expects that an object's length can be greater than or equal to the length of the known object revision. When evaluating objects with revision numbers greater than that known by OSPM, OSPM ignores internal object fields values that are beyond the defined object field range for the known revision.

5.4 Definition Block Encoding

This section specifies the encoding used in a Definition Block to define names (load time only), objects, and packages.

5.4.1 AML Encoding

The Definition Block is encoded as a stream from beginning to end. The lead byte in the stream comes from the AML encoding tables shown in *ACPI Source Language (ASL) Reference* and signifies how to interpret some number of following bytes, where each following byte can in turn signify how to interpret some number of following bytes. For a full specification of the AML encoding, see *ACPI Source Language (ASL) Reference*.

Within the stream there are two levels of data being defined. One is the packaging and object declarations (load time), and the other is an object reference (package contents/run-time).

All encodings are such that the lead byte of an encoding signifies the type of declaration or reference being made. The type either has an implicit or explicit length in the stream. All explicit length declarations take the form shown below, where PkgLength is the length of the inclusive length of the data for the operation.

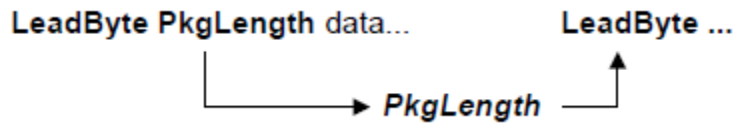

Fig. 5.17: AML Encoding

Encodings of implicit length objects either have fixed length encodings or allow for nested encodings that, at some point, either result in an explicit or implicit fixed length.

The PkgLength is encoded as a series of 1 to 4 bytes in the stream with the most significant two bits of byte zero, indicating how many following bytes are in the PkgLength encoding. The next two bits are only used in one-byte encodings, which allows for one-byte encodings on a length up to 0x3F. Longer encodings, which do not use these two bits, have a maximum length of the following: two-byte encodings of 0x0FFF, three-byte encodings of 0x0FFFFF, and four-byte length encodings of 0x0FFFFFFF.

It is fatal for a package length to not fall on a logical boundary. For example, if a package is contained in another package, then by definition its length must be contained within the outer package, and similarly for a datum of implicit length.

5.4.2 Definition Block Loading

At some point, the system software decides to “load” a Definition Block. Loading is accomplished when the system makes a pass over the data and populates the ACPI namespace and initializes objects accordingly. The namespace for which population occurs is either from the current namespace location, as defined by all nested packages or from the root if the name is preceded with “.”.

The first object present in a Definition Block must be a named control method. This is the Definition Block’s initialization control.

Packages are objects that contain an ordered reference to one or more objects. A package can also be considered a vertex of an array, and any object contained within a package can be another package. This permits multidimensional arrays of fixed or dynamic depths and vertices.

Unnamed objects are used to populate the contents of named objects. Unnamed objects cannot be created in the “root.” Unnamed objects can be used as arguments in control methods.

Control method execution may generate errors when creating objects. This can occur if a Method that creates named objects blocks and is reentered while blocked. This will happen because all named objects have an absolute path. This is true even if the object name specified is relative. For example, the following ASL code segments are functionally identical.

(1)

```
Method (DEAD)
{
    Scope (\_SB_.FOO)
    {
        Name (BAR,0x1234) // Run time definition
    }
}
```

(2)

```
Scope (\_SB_)
{
    Name (\_SB_.FOO.BAR,) // Load time definition
}
```

Notice that in the above example the execution of the DEAD method will always fail because the object `_SB_.FOO.BAR` is created at load time.

The term of “Definition Block level” is used to refer to the AML byte streams that are not contained in any control method. Such AML byte streams can appear in the “root” scope or in the scopes created/opened by the “Device, PowerResource, Processor, Scope and ThermalZone” operators. Please refer to “*ASL Operator Reference* , ASL Operator Reference” for detailed descriptions.

Not only the named objects, but all term objects (mathematical, logical, and conditional expressions, etc., see “*Term Objects Encoding* , Term Object Encoding”) are allowed at the Definition Block level. Allowing such executable AML opcodes at the Definition Block level allows BIOS writers to define dynamic object lists according to the system settings. For example:

```
DefinitionBlock ("DSDT.aml", "DSDT", 2, "OEM", "FOOBOOK", 0x1000)
{
    ...
    If (CFG1 () == 1)
    {
        ...
        Scope (_SB.PCI0.XHC.RHUB)
        {
            ...
            If (CFG2 () == 1)
            {
                ...
                Device (HS11)
                {
                    ...
                    If (CFG3 () == 1)
                    {
                        ...
                        Device (CAM0)
                        {
                            ...
                        }
                    }
                }
            }
        }
    }
    ...
}
```

(continues on next page)

(continued from previous page)

```

    }
    ...
  }
  ...
}
...
}
...
}
...
}
...
}
...
}

```

The interpretation of the definition block during the definition block loading is similar to the interpretation of the control method during the control method execution.

5.5 Control Methods and the ACPI Source Language (ASL)

OEMs and platform firmware vendors write definition blocks using the ACPI Source Language (ASL) and use a translator to produce the byte stream encoding described in *Definition Block Encoding*. For example, the ASL statements that produce the example byte stream shown in that earlier section are shown in the following ASL example. For a full specification of the ASL statements, see *ACPI Source Language (ASL) Reference*.

```

DefinitionBlock (
  "forbook.aml",          // Output Filename
  "DSDT",                // Signature
  0x02,                  // DSDT Compliance Revision
  "OEM",                  // OEMID
  "forbook",             // TABLE ID
  0x1000                  // OEM Revision
)
{
  // start of definition block
  OperationRegion(\GIO, SystemIO, 0x125, 0x1)
  Field(\GIO, ByteAcc, NoLock, Preserve)
  {
    CT01, 1,
  }

  Scope(\_SB)
  { // start of scope
    Device(PCI0)
    { // start of device
      PowerResource(FET0, 0, 0)
      { // start of pwr
        Method (_ON)
        {
          CT01 = Ones // assert power
          Sleep (30) // wait 30ms
        }

        Method (_OFF)
        {
          CT01 = Zero // assert reset#
        }
      }
    }
  }
}

```

(continues on next page)

(continued from previous page)

```

        Method (_STA)
        {
            Return (CT01)
        }
    } // end of power
} // end of device
} // end of scope
} // end of definition block

```

5.5.1 ASL Statements

ASL is principally a declarative language. ASL statements declare objects. Each object has three parts, two of which can be null:

```
Object := ObjectType FixedList VariableList
```

FixedList refers to a list of known length that supplies data that all instances of a given ObjectType must have. It is written as (a, b, c,), where the number of arguments depends on the specific ObjectType, and some elements can be nested objects, that is (a, b, (q, r, s, t), d). Arguments to a FixedList can have default values, in which case they can be skipped. Some ObjectTypes can have a null FixedList.

VariableList refers to a list, not of predetermined length, of child objects that help define the parent. It is written as {x, y, z, aa, bb, cc}, where any argument can be a nested object. ObjectType determines what terms are legal elements of the VariableList. Some ObjectTypes can have a null variable list.

For a detailed specification of the ASL language, see *ACPI Source Language (ASL) Reference*

5.5.2 Control Method Execution

OSPM evaluates control method objects as necessary to either interrogate or adjust the system-level hardware state. This is called an invocation.

A control method can use other internal, or well defined, control methods to accomplish the task at hand, which can include defined control methods provided by the operating software. Control Methods can reference any objects anywhere in the Namespace. Interpretation of a Control Method is not preemptive, but it can block. When a control method does block, OSPM can initiate or continue the execution of a different control method. A control method can only assume that access to global objects is exclusive for any period the control method does not block.

Global objects are those NameSpace objects created at table load time.

5.5.2.1 Arguments

Up to seven arguments can be passed to a control method. Each argument is an object that in turn could be a “package” style object that refers to other objects. Access to the argument objects is provided via the ASL ArgTerm (ArgX) language elements. The number of arguments passed to any control method is fixed and is defined when the control method package is created.

Method arguments can take one of the following forms:

- An ACPI name or namepath that refers to a named object. This includes the LocalX and ArgX names. In this case, the object associated with the name is passed as the argument.

- An ACPI name or namepath that refers to another control method. In this case, the method is invoked and the return value of the method is passed as the argument. A fatal error occurs if no object is returned from the method. If the object is not used after the method invocation it is automatically deleted.
- A valid ASL expression. In the case, the expression is evaluated and the object that results from this evaluation is passed as the argument. If this object is not used after the method invocation it is automatically deleted.

5.5.2.2 Method Calling Convention

The calling convention for control methods can best be described as call-by-reference-constant. In this convention, objects passed as arguments are passed by “reference”, meaning that they are not copied to new objects as they are passed to the called control method (A calling convention that copies objects or object wrappers during a call is known as call-by-value or call-by-copy).

This call-by-reference-constant convention allows internal objects to be shared across each method invocation, therefore reducing the number of object copies that must be performed as well as the number of buffers that must be copied. This calling convention is appropriate to the low-level nature of the ACPI subsystem within the kernel of the host operating system where non-paged dynamic memory is typically at a premium. The ASL programmer must be aware of the calling convention and the related side effects.

However, unlike a pure call-by-reference convention, the ability of the called control method to modify arguments is extremely limited. This reduces aliasing issues such as when a called method unexpectedly modifies a object or variable that has been passed as an argument by the caller. In effect, the arguments that are passed to control methods are passed as constants that cannot be modified except under specific controlled circumstances.

Generally, the objects passed to a control method via the ArgX terms cannot be directly written or modified by the called method. In other words, when an ArgX term is used as a target operand in an ASL statement, the existing ArgX object is not modified. Instead, the new object replaces the existing object and the ArgX term effectively becomes a LocalX term.

The only exception to the read-only argument rule is if an ArgX term contains an Object Reference created via the RefOf ASL operator. In this case, the use of the ArgX term as a target operand will cause any existing object stored at the ACPI name referred to by the RefOf operation to be overwritten.

In some limited cases, a new, writable object may be created that will allow a control method to change the value of an ArgX object. These cases are limited to Buffer and Package objects where the “value” of the object is represented indirectly. For Buffers, a writable Index or Field can be created that refers to the original buffer data and will allow the called method to read or modify the data. For Packages, a writable Index can be created to allow the called method to modify the contents of individual elements of the Package.

5.5.2.3 Local Variables and Locally Created Data Objects

Control methods can access up to eight local data objects. Access to the local data objects have shorthand encodings. On initial control method execution, the local data objects are NULL. Access to local objects is via the ASL LocalTerm language elements.

Upon control method execution completion, one object can be returned that can be used as the result of the execution of the method. The “caller” must either use the result or save it to a different object if it wants to preserve it. See the description of the Return ASL operator for additional details

NameSpace objects created within the scope of a method are dynamic. They exist only for the duration of the method execution. They are created when specified by the code and are destroyed on exit. A method may create dynamic objects outside of the current scope in the NameSpace using the scope operator or using full path names. These objects will still be destroyed on method exit. Objects created at load time outside of the scope of the method are static. For example:

```

Scope (\XYZ)
{
    Name (BAR, 5)           // Creates \\XYZ.BAR
    Method (FOO, 1)
    {
        CREG = BAR         // same effect as CREG = \\XYZ.BAR
        Name (BAR, 7)      // Creates \\XYZ.FOO.BAR
        DREG = BAR         // same effect as DREG = \\XYZ.FOO.BAR
        Name (\XYZ.FOOB, 3) // Creates \\XYZ.FOOB
    }                       // end method
}                           // end scope
    
```

The object \XYZ.BAR is a static object created when the table that contains the above ASL is loaded. The object \XYZ.FOO.BAR is a dynamic object that is created when the Name (BAR, 7) statement in the FOO method is executed. The object \XYZ.FOOB is a dynamic object created by the \XYZ.FOO method when the Name (XYZ.FOOB, 3) statement is executed. Notice that the \XYZ.FOOB object is destroyed after the \XYZ.FOO method exits.

5.5.2.4 Access to Operation Regions

5.5.2.4.1 Operation Regions

Control Methods read and write data to locations in address spaces (for example, System memory and System I/O) by using the Field operator (see Declare Field Objects) to declare a data element within an entity known as an “Operation Region” and then performing accesses using the data element name. An Operation Region is a specific region of operation within an address space that is declared as a subset of the entire address space using a starting address (offset) and a length (see *OperationRegion (Declare Operation Region)*). Control methods must have exclusive access to any address accessed via fields declared in Operation Regions. Control methods may not directly access any other hardware registers, including the ACPI-defined register blocks. Some of the ACPI registers, in the defined ACPI registers blocks, are maintained on behalf of control method execution. For example, the GPE_x_BLK is not directly accessed by a control method but is used to provide an extensible interrupt handling model for control method invocation.

- Accessing an OpRegion may block, even if the OpRegion is not protected by a mutex. For example, because of the slow nature of the embedded controller, an embedded controller OpRegion field access may block.

The following table defines Operation Region spaces.

Table 5.182: Operation Region Address Space Identifiers

Value	Name (RegionSpace Keyword)	Reference
0	SystemMemory	
1	SystemIO	
2	PCI_Config	
3	EmbeddedControl	See ACPI Embedded Controller Interface Specification
4	SMBus	See ACPI System Management Bus Interface Specification
5	SystemCMOS	See CMOS Protocols
6	PciBarTarget	See PCI Device BAR Target Protocols
7	IPMI	See Declaring IPMI Operation Regions
8	GeneralPurposeIO	See Declaring GeneralPurposeIO Operation Regions

continues on next page

Table 5.182 – continued from previous page

9	GenericSerialBus	See Declaring GenericSerialBus Operation Regions
0x0A	PCC	See Declaring PCC Operation Regions
0x0B	PlatformRtMechanism	Operation Region used by the Platform Runtime Mechanism Table. See Links to ACPI-Related Documents (https://uefi.org/acpi) under the heading “Platform Runtime Mechanism Table”.
0x0C-0x7E	<i>Reserved</i>	
0x07F	FFixedHW (FFH)	See Declaring Functional Fixed Hardware (FFH) Operation Regions (Section 5.5.2.4.2).
0x80 to 0xFF	OEM defined	

5.5.2.4.2 Declaring Functional Fixed Hardware (FFH) Operation Regions

The syntax for declaring and using the Functional Fixed Hardware (FFH) Operation Region is architecture specific. Please refer to architecture specific documentation for the definition. For ARM FFixedHW Operation Region definition, see Links to ACPI-Related Documents (<https://uefi.org/acpi>) under the heading “ARM FFH Specification”.

The use of functional fixed hardware carries with it a reliance on OS specific software that must be considered. OEMs should consult OS vendors to ensure that specific functional fixed hardware interfaces are supported by specific operating systems. The OS and the platform can handshake on support for the FFH Operation Regions using the _OSC method as described in Platform-Wide OSPM Capabilities (Section 6.2.11.2).

5.5.2.4.3 CMOS Protocols

This section describes how CMOS battery-backed non-volatile memory can be accessed from ASL. Most computers contain an RTC/CMOS device that can be represented as a linear array of bytes of non-volatile memory. There is a standard mechanism for accessing the first 64 bytes of non-volatile RAM in devices that are compatible with the Motorola RTC/CMOS device used in the original IBM PC/AT. Existing RTC/CMOS devices typically contain more than 64 bytes of non-volatile RAM, and no standard mechanism exists for access to this additional storage area. To provide access to all of the non-volatile memory in these devices from AML, PnP IDs exist for each type of extension. These are PNP0B00, PNP0B01, and PNP0B02. The specific devices that these PnP IDs support are described in *PC/AT RTC/CMOS Devices*, along with field definition ASL example code. The drivers corresponding to these device handle operation region accesses to the SystemCMOS operation region for their respective device types.

All bytes of CMOS that are related to the current time, day, date, month, year and century are read-only.

5.5.2.4.4 PCI Device BAR Target Protocols

This section describes how PCI devices’ control registers can be accessed from ASL. PCI devices each have an address space associated with them called the Configuration Space. At offset 0x10 through offset 0x27, there are as many as six Base Address Registers, (BARs). These BARs contain the base address of a series of control registers (in I/O or Memory space) for the PCI device. Since a Plug and Play OS may change the values of these BARs at any time, ASL cannot read and write from these deterministically using I/O or Memory operation regions. Furthermore, a Plug and Play OS will automatically assign ownership of the I/O and Memory regions associated with these BARs to a device driver associated with the PCI device. An ACPI OS (which must also be a Plug and Play operating system) will not allow ASL to read and write regions that are owned by native device drivers.

If a platform uses a PCI BAR Target operation region, an ACPI OS will not load a native device driver for the associated PCI function. For example, if any of the BARs in a PCI function are associated with a PCI BAR Target operation region, then the OS will assume that the PCI function is to be entirely under the control of the ACPI system firmware. No driver will be loaded. Thus, a PCI function can be used as a platform controller for some task (hot-plug PCI, and so on) that the ACPI system firmware performs.

5.5.2.4.4.1 Declaring a PCI BAR Target Operation Region

PCI BARs contain the base address of an I/O or Memory region that a PCI device's control registers lie within. Each BAR implements a protocol for determining whether those control registers are within I/O or Memory space and how much address space the PCI device decodes. (See the PCI Specification for more details.)

PCI BAR Target operation regions are declared by providing the offset of the BAR within the PCI device's PCI configuration space. The BAR determines whether the actual access to the device occurs through an I/O or Memory cycle, not by the declaration of the operation region. The length of the region is similarly implied.

In the term `OperationRegion(PBAR, PciBarTarget, 0x10, 0x4)`, the offset is the offset of the BAR within the configuration space of the device. This would be an example of an operation region that uses the first BAR in the device.

5.5.2.4.4.2 PCI Header Types and PCI BAR Target Operation Regions

PCI BAR Target operation regions may only be declared in the scope of PCI devices that have a PCI Header Type of 0. PCI devices with other header types are bridges. The control of PCI bridges is beyond the scope of ASL.

5.5.2.4.5 Declaring IPMI Operation Regions

This section describes the Intelligent Platform Management Interface (IPMI) address space and the use of this address space to communicate with the Baseboard Management Controller (BMC) hardware from AML.

Similar to SMBus, IPMI operation regions are command based, where each offset within an IPMI address space represent an IPMI command and response pair. Given this uniqueness, IPMI operation regions include restrictions on their field definitions and require the use of an IPMI-specific data buffer for all transactions. The IPMI interface presented in this section is intended for use with any hardware implementation compatible with the IPMI specification, regardless of the system interface type.

Support of the IPMI generic address space by ACPI-compatible operating systems is optional, and is contingent on the existence of an ACPI IPMI device, i.e. a device with the "IPI0001" plug and play ID. If present, OSPM should load the necessary driver software based on the system interface type as specified by the `_IFT` (IPMI Interface Type) control method under the device, and register handlers for accesses into the IPMI operation region space.

For more information, refer to the IPMI specification.

Each IPMI operation region definition identifies a single IPMI network function. Operation regions are defined only for those IPMI network functions that need to be accessed from AML. As with other regions, IPMI operation regions are only accessible via the Field term (see *Declaring IPMI Fields*).

This interface models each IPMI network function as having a 256-byte linear address range. Each byte offset within this range corresponds to a single command value (for example, byte offset 0xC1 equates to command value 0xC1), with a maximum of 256 command values. By doing this, IPMI address spaces appear linear and can be processed in a manner similar to the other address space types.

The syntax for the `OperationRegion` term (from *OperationRegion (Declare Operation Region)*) is described below:

```

OperationRegion (
    RegionName,    // NameString
    RegionSpace,  // RegionSpaceKeyword
    Offset,       // TermArg=>Integer
    Length        // TermArg=>Integer
)
    
```

Where:

- RegionName specifies a name for this IPMI network function (for example, "POWR").
- RegionSpace must be set to IPMI (operation region type value 0x07).
- Offset is a word-sized value specifying the network function and initial command value offset for the target device. The network function address is stored in the high byte and the command value offset is stored in the low byte. For example, the value 0x3000 would be used for a device with the network function of 0x06, and an initial command value offset of zero (0).
- Length is set to the 0x100 (256), representing the maximum number of possible command values, for regions with an initial command value offset of zero (0). The difference of these two values is used for regions with non-zero offsets. For example, a region with an Offset value of 0x3010 would have a corresponding Length of 0xF0 (0x100 minus 0x10).

For example, a Baseboard Management Controller will support power metering capabilities at the network function 0x30, and IPMI commands to query the BMC device information at the network function 0x06.

The following ASL code shows the use of the OperationRegion term to describe these IPMI functions:

```

Device (IPMI)
{
    Name (_HID, "IPI0001")           // IPMI device
    Name (_IFT, 0x1)                // KCS system interface type
    OperationRegion (DEVC, IPMI, 0x0600, 0x100) // Device info network function
    OperationRegion (POWR, IPMI, 0x3000, 0x100) // Power network function
}
    
```

Notice that these operation regions in this example are defined within the immediate context of the 'owning' IPMI device. This ensures the correct operation region handler will be used, based on the value returned by the _IFT object. Each definition corresponds to a separate network function, and happens to use an initial command value offset of zero (0).

5.5.2.4.5.1 Declaring IPMI Fields

As with other regions, IPMI operation regions are only accessible via the Field term. Each field element is assigned a unique command value and represents a virtual command for the targeted network function.

The syntax for the Field term (from *Event (Declare Event Synchronization Object)*) is described below:

```

Field(
    RegionName,    // NameString=>OperationRegion
    AccessType,   // AccessTypeKeyword - BufferAcc
    LockRule,     // LockRuleKeyword
    UpdateRule    // UpdateRuleKeyword - ignored
) {FieldUnitList}
    
```

Where:

- RegionName specifies the operation region name previously defined for the network function.

- `AccessType` must be set to `BufferAcc`. This indicates that access to field elements will be done using a region-specific data buffer. For this access type, the field handler is not aware of the data buffer's contents which may be of any size. When a field of this type is used as the source argument in an operation it simply evaluates to a buffer. When used as the destination, however, the buffer is passed bi-directionally to allow data to be returned from write operations. The modified buffer then becomes the response message of that command. This is slightly different than the normal case in which the execution result is the same as the value written to the destination. Note that the source is never changed, since it only represents a virtual register for a particular IPMI command.
- `LockRule` indicates if access to this operation region requires acquisition of the Global Lock for synchronization. This field should be set to `Lock` on system with firmware that may access the BMC via IPMI, and `NoLock` otherwise.
- `UpdateRule` is not applicable to IPMI operation regions since each virtual register is accessed in its entirety. This field is ignored for all IPMI field definitions.

IPMI operation regions require that all field elements be declared at command value granularity. This means that each virtual register cannot be broken down to its individual bits within the field definition.

Access to sub-portions of virtual registers can be done only outside of the field definition. This limitation is imposed both to simplify the IPMI interface and to maintain consistency with the physical model defined by the IPMI specification.

Since the system interface used for IPMI communication is determined by the `_IFT` object under the IPMI device, there is no need for using of the `AccessAs` term within the field definition. In fact its usage will be ignored by the operation handler.

For example, the register at command value `0xC1` for the power meter network function might represent the command to set a BMC enforced power limit, while the register at command value `0xC2` for the same network function might represent the current configured power limit. At the same time, the register at command value `0xC8` might represent the latest power meter measurement.

The following ASL code shows the use of the `OperationRegion`, `Field`, and `Offset` terms to represent these virtual registers:

```

OperationRegion(POWR, IPMI, 0x3000, 0x100) // Power network function
Field(POWR, BufferAcc, NoLock, Preserve)
{
    Offset(0xC1),           // Skip to command value 0xC1
    SPWL, 8,               // Set power limit [command value 0xC1]
    GPWL, 8,               // Get power limit [command value 0xC2]
    Offset(0xC8),         // Skip to command value 0xC8
    GPMM, 8                // Get power meter measurement [command value 0xC8]
}
    
```

Notice that command values are equivalent to the field element's byte offset (for example, `SPWL=0xC1`, `GPWL=0xC2`, `GPMM=0xC8`).

5.5.2.4.5.2 Declaring and Using IPMI Request and Response Buffer

Since each virtual register in the IPMI operation region represents an individual IPMI command, and the operation relies on use of bi-directional buffer, a common buffer structure is required to represent the request and response messages. The use of a data buffer for IPMI transactions allows AML to receive status and data length values.

The IPMI data buffer is defined as a fixed-length 66-byte buffer that, if represented using a ‘C’-styled declaration, would be modeled as follows:

```
typedef struct
{
  BYTE Status;      // Byte 0 of the data buffer
  BYTE Length;     // Byte 1 of the data buffer
  BYTE[64] Data;   // Bytes 2 through 65 of the data buffer
}
```

Where:

- Status (byte 0) indicates the status code of a given IPMI command. See *IPMI Status Code* for more information.
- Length (byte 1) specifies the number of bytes of valid data that exists in the data buffer. Valid Length values are 0 through 64. Before the operation is carried out, this value represents the length of the request data buffer. Afterwards, this value represents the length of the result response data buffer.
- Data (bytes 65-2) represents a 64-byte buffer, and is the location where actual data is stored. Before the operation is carried out, this represents the actual request message payload. Afterwards, this represents the response message payload as returned by the IPMI command.

For example, the following ASL shows the use of the IPMI data buffer to carry out a command for a power function. This code is based on the example ASL presented in *Declaring IPMI Fields* which lists the operation region and field definitions for relevant IPMI power metering commands.

```
/* Create the IPMI data buffer */
Name (BUFF, Buffer (66) {}) // Create IPMI data buffer as BUFF
CreateByteField (BUFF, 0x00, STAT) // STAT = Status (Byte)
CreateByteField (BUFF, 0x01, LENG) // LENG = Length (Byte)
CreateByteField (BUFF, 0x02, MODE) // MODE = Mode (Byte)
CreateByteField (BUFF, 0x03, RESV) // RESV = Reserved (Byte)

LENG = 0x2 // Request message is 2 bytes long
MODE = 0x1 // Set Mode to 1

BUFF = (GPMM = BUFF) // Write the request into the GPMM command,
// then read the results

CreateByteField (BUFF, 0x02, CMPC) // CMPC = Completion code (Byte)
CreateWordField (BUFF, 0x03, APOW) // APOW = Average power measurement (Word)

If ((STAT == 0x0) && (CMPC == 0x0)) // Successful?
{
  Return (APOW) // Return the average power measurement
}
Else
{
  Return (Ones) // Return invalid
}
```

Notice the use of the CreateField primitives to access the data buffer’s sub-elements (Status, Length, and Data), where Data (bytes 65-2) is ‘typecast’ into different fields (including the result completion code).

The example above demonstrates the use of the Store() operator and the bi-directional data buffer to invoke the actual IPMI command represented by the virtual register. The inner Store() writes the request message data buffer to the IPMI operation region handler, and invokes the command. The outer Store() takes the result of that command and writes it back into the data buffer, this time representing the response message.

5.5.2.4.5.3 IPMI Status Code

Every IPMI command results in a status code returned as the first byte of the response message, contained in the bi-directional data buffer. This status code can indicate success, various errors, and possibly timeout from the IPMI operation handler. This is necessary because it is possible for certain IPMI commands to take up to 5 seconds to carry out, and since an AML Store() operation is synchronous by nature, it is essential to make sure the IPMI operation returns in a timely fashion so as not to block the AML interpreter in the OSPM.

- This status code is different than the IPMI completion code, which is returned as the first byte of the response message in the data buffer payload. The completion code is described in the complete IPMI specification.

Table 5.183: IPMI Status Codes

Status Code	Name	Description
00h	IPMI OK	Indicates the command has been successfully completed.
07h	IPMI Unknown Failure	Indicates failure because of an unknown IPMI error.
10h	IPMI Command Operation Timeout	Indicates the operation timed out.

5.5.2.4.6 Declaring GeneralPurposeIO Operation Regions

For GeneralPurposeIO Operation Regions, the syntax for the OperationRegion term (from section *OperationRegion (Declare Operation Region)*) is described below:

```

OperationRegion (
    RegionName,          // NameString
    RegionSpace,        // RegionSpaceKeyword
    Offset,             // TermArg=>Integer
    Length              // TermArg=>Integer
)
    
```

Where:

- RegionName specifies a name for this GeneralPurposeIO region (for example, “GPI1”).
- RegionSpace must be set to GeneralPurposeIO (operation region type value 0x08).
- Offset is ignored for the GeneralPurposeIO RegionSpace.
- Length is the maximum number of GPIO IO pins to be included in the Operation Region, rounded up to the next byte.

GeneralPurposeIO OpRegions must be declared within the scope of the GPIO controller device being accessed.

5.5.2.4.6.1 Declaring GeneralPurposeIO Fields

As with other regions, GeneralPurposeIO operation regions are only accessible via the Field term. Each field element represents a subset of the length bits declared in the OpRegion declaration. The pins within the OpRegion that are accessed via a given field name are defined by a Connection descriptor. The total number of defined field bits following a connection descriptor must equal the number of pins listed in the descriptor.

The syntax for the Field term (from *Field (Declare Field Objects)*) is described below:

```
Field(
  RegionName, // NameString=>OperationRegion
  AccessType, // AccessTypeKeyword
  LockRule,   // LockRuleKeyword
  UpdateRule // UpdateRuleKeyword - ignored
) {FieldUnitList}
```

Where:

- RegionName specifies the operation region name previously declared.
- AccessType must be set to ByteAcc.
- LockRule indicates if access to this operation region requires acquisition of the Global Lock for synchronization. Note that, on HW-reduced ACPI platforms, this field must be set to NoLock.
- UpdateRule is not applicable to GeneralPurposeIO operation regions since Preserve is always required. This field is ignored for all GeneralPurposeIO field definitions.

The following ASL code shows the use of the OperationRegion, Field, and Offset terms as they apply to GeneralPurposeIO space.

```
Device(DEVA) //An Arbitrary Device Scope
{
  // Other required stuff for this device
  Name (GMOD, ResourceTemplate ()
    //An existing GPIO Connection (to be used later)
    {
      //2 Outputs that define the Power mode of the device
      GpioIo (Exclusive, PullDown, , , , "\\_SB.GPIO2") {10, 12}
    })
} //End DEVA

Device (GPIO2) //The OpRegion declaration, and the _REG method,
               //must be in the controller's namespace scope
{
  //Other required stuff for the GPIO controller
  OperationRegion(GPO2, GeneralPurposeIO, 0, 1)
  // Note: length of 1 means region is less than 1 byte (8 pins) long
  Method(_REG,2)
  {
    // Track availability of GeneralPurposeIO space
  }
}

Device (DEVB) //Access some GPIO Pins from this device scope
              //to change the device's power mode
{
  //.. Other required stuff for this device
```

(continues on next page)

(continued from previous page)

```

Name(_DEP, Package() {"\\_SB.GPI2"}) //OpRegion Dependency hint for OSPM
Field(_SB.GPI2.GPO2, ByteAcc, NoLock, Preserve)
{
    Connection (GMOD), // Re-Use an existing connection (defined elsewhere)
    MODE, 2, // Power Mode
    Connection (GpioIo(Exclusive, PullUp, , , , "\\_SB.GPI2") {7}),
    STAT, 1, // e.g. Status signal from the device
    Connection (GpioIo (Exclusive, PullUp, , , , "\\_SB.GPI2") {9}),
    RSET, 1 // e.g. Reset signal to the device
}

Method(_PS3)
{
    If (1) // Make sure GeneralPurposeIO OpRegion is available
    {
        MODE = 0x03 //Set both MODE bits. Power Mode 3
    }
}
} //End DEVB

```

5.5.2.4.7 Declaring GenericSerialBus Operation Regions

For GenericSerialBus Operation Regions, the syntax for the OperationRegion term (from *OperationRegion (Declare Operation Region)*) is described below:

```

OperationRegion (
    RegionName, // NameString
    RegionSpace, // RegionSpaceKeyword
    Offset, // TermArg=>Integer
    Length // TermArg=>Integer
)

```

Where:

- RegionName specifies a name for this region (for example, TOP1).
- RegionSpace must be set to GenericSerialBus (operation region type value 0x09).
- Offset specifies the initial command value offset for the target device. For example, the value 0x00 refers to a command value offset of zero (0). Raw protocols ignore this value.
- Length is set to the 0x100 (256), representing the maximum number of possible command values.
- The Operation Region must be declared within the scope of the Serial Bus controller device.

The following ASL code shows the use of the OperationRegion, Field, and Offset terms as they apply to SPB space.

```

Scope(_SB.I2C)
{
    Name (SDB0, ResourceTemplate()
    {
        I2CSerialBusV2(0x4a,,100000,, "
            \\_SB.I2C",,,,,RawDataBuffer() {1,2,3,4,5,6})
    })

    OperationRegion(TOP1, GenericSerialBus, 0x00, 0x100)
        // GenericSerialBus device at command offset 0x00

```

(continues on next page)

(continued from previous page)

```

Field(TOP1, BufferAcc, NoLock, Preserve)
{
    Connection(SDB0,
        // Use the Resource Descriptor defined above
    AccessAs(BufferAcc, AttribWord),
        // Use the GenericSerialBus Read/Write Word protocol
    FLD0, 8, // Virtual register at command value 0.
    FLD1, 8 // Virtual register at command value 1.
}

Field(TOP1, BufferAcc, NoLock, Preserve)
{
    Connection(I2CSerialBusV2(0x5a,,100000,,
        \\_SB.I2C",,,,,RawDataBuffer(){1,6})),
    AccessAs(BufferAcc, AttribBytes (16)),
    FLD2, 8 // Virtual register at command value 0.
}

// Create the GenericSerialBus data buffer

Name(BUFF, Buffer(34){}) // Create GenericSerialBus data buffer as BUFF

CreateByteField(BUFF, 0x00, STAT) // STAT = Status (Byte)
CreateWordField(BUFF, 0x02, DATA) // DATA = Data (Word)
}

```

The Operation Region in this example is defined within the scope of the target controller device, I2C.

GenericSerialBus regions are only accessible via the Field term (see Declare Field Objects). GenericSerialBus protocols are assigned to field elements using the AccessAs term (see “ASL Macros”) within the field definition.

Table 5.184: Accessor Type Values

Accessor Type	Value	Description
AttribQuick	0x02	Read/Write Quick Protocol
AttribSendReceive	0x04	Send/Receive Byte Protocol
AttribByte	0x06	Read/Write Byte Protocol
AttribWord	0x08	Read/Write Word Protocol
AttribBlock	0x0A	Read/Write Block Protocol
AttribBytes	0x0B	Read/Write N-Bytes Protocol
AttribProcessCall	0x0C	Process Call Protocol
AttribBlockProcessCall	0x0D	Write Block-Read Block Process Call Protocol
AttribRawBytes	0x0E	Raw Read/Write N-Bytes Protocol
AttribRawProcessBytes	0x0F	Raw Process Call Protocol

5.5.2.4.7.1 Declaring GenericSerialBus Fields

As with other regions, GenericSerialBus operation regions are only accessible via the Field term. Each field element is assigned a unique command value and represents a virtual register on the targeted GenericSerialBus device.

The syntax for the Field term (see Section 19.6.47) is described below:

```
Field(
  RegionName,      // NameString=>OperationRegion
  AccessType,      // AccessTypeKeyword
  LockRule,        // LockRuleKeyword - ignored for Hardware-reduced ACPI platforms
  UpdateRule       // UpdateRuleKeyword - ignored
) {FieldUnitList}
```

Where:

- RegionName specifies the operation region name previously defined for the device.
- AccessType must be set to BufferAcc. This indicates that access to field elements will be done using a region-specific data buffer. For this access type, the field handler is not aware of the data buffer's contents which may be of any size. When a field of this type is used as the source argument in an operation it simply evaluates to a buffer. When used as the destination, however, the buffer is passed bi-directionally to allow data to be returned from write operations. The modified buffer then becomes the execution result of that operation. This is slightly different than the normal case in which the execution result is the same as the value written to the destination. Note that the source is never changed, since it could be a read only object (see *Declaring and Using a GenericSerialBus Data Buffer*).
- LockRule indicates if access to this operation region requires acquisition of the Global Lock for synchronization. This field should be set to Lock on system with firmware that may access the GenericSerialBus, and NoLock otherwise. On Hardware-reduced ACPI platforms, there is not a global lock so this parameter is ignored.
- UpdateRule is not applicable to GenericSerialBus operation regions since each virtual register is accessed in its entirety. This field is ignored for all GenericSerialBus field definitions.

GenericSerialBus operation regions require that all field elements be declared at command value granularity. This means that each virtual register cannot be broken down to its individual bits within the field definition.

Access to sub-portions of virtual registers can be done only outside of the field definition. This limitation is imposed to simplify the GenericSerialBus interface.

GenericSerialBus protocols are assigned to field elements using the AccessAs term within the field definition. The syntax for this term (from *ASL Root and Secondary Terms*) is described below:

```
AccessAs (
  AccessType, //AccessTypeKeyword
  AccessAttribute //Nothing \ | ByteConst \ | AccessAttribKeyword
)
```

Where:

- AccessType must be set to BufferAcc.
- AccessAttribute indicates the GenericSerialBus protocol to assign to command values that follow this term. See: *ref:using-the-genericserialbus-protocols* for a listing of the GenericSerialBus protocols.

An AccessAs term must appear in a field definition to set the initial GenericSerialBus protocol for the field elements that follow. A maximum of one GenericSerialBus protocol may be defined for each field element. Devices supporting multiple protocols for a single command value can be modeled by specifying multiple field elements with the same offset (command value), where each field element is preceded by an AccessAs term specifying an alternate protocol.

For GenericSerialBus operation regions, connection attributes must be defined for each set of field elements. GenericSerialBus resources are assigned to field elements using the Connection term within the field definition. The syntax for this term (from *Connection (Declare Field Connection Attributes)* “Connection (Declare Field Connection Attributes)”) is described below:

```
Connection (ConnectionResourceObj)
```

Where:

- ConnectionResourceObj points to a Serial Bus Resource Connection Descriptor (see *GenericSerialBus Connection Descriptors* for valid types), or a named object that specifies a buffer field containing the connection resource information.

Each Field definition references the initial command offset specified in the operation region definition. The offset is iterated for each subsequent field element defined in that respective Field. If a new connection is described in the same Field definition, the offset will not be returned to its initial value and a new Field must be defined to inherit the initial command value offset from the operation region definition. The following example illustrates this point.

```
OperationRegion (TOP1, GenericSerialBus, 0x00, 0x100) //Initial offset is 0
Field (TOP1, BufferAcc, NoLock, Preserve)
{
    Connection (I2CSerialBusV2 (0x5a,,100000,, "\\_SB.I2C",,,,,RawDataBuffer() {1,6})),
    Offset (0x0),
    AccessAs(BufferAcc, AttribBytes (4)),
    TFK1, 8, //TFK1 at command value offset 0
    TFK2, 8, //TFK2 at command value offset 1
    Connection (I2CSerialBusV2 (0x5c,,100000,, "\\_SB.I2C",,,,,RawDataBuffer() {3,1})),
    AccessAs(BufferAcc, AttribBytes (12)),
    TS1, 8 //TS1 at command value offset 2
}

Field (TOP1, BufferAcc, NoLock, Preserve)
{
    Connection (I2CSerialBusV2 (0x5b,,100000,, "\\_SB.I2C",,,,,RawDataBuffer() {2,9})),
    AccessAs(BufferAcc, AttribByte),
    TM1, 8 //TM1 at command value offset 0
}
```

5.5.2.4.7.2 Declaring and Using a GenericSerialBus Data Buffer

The use of a data buffer for GenericSerialBus transactions allows AML to receive status and data length values, as well as making it possible to implement the Process Call protocol. The BufferAcc access type is used to indicate to the field handler that a region-specific data buffer will be used.

For GenericSerialBus operation regions, this data buffer is defined as an arbitrary length buffer that, if represented using a ‘C’-styled declaration, would be modeled as follows:

```
typedef struct
{
    BYTE Status;           // Byte 0 of the data buffer
    BYTE Length;          // Byte 1 of the data buffer
    BYTE[x-1] Data;       // Bytes 2-x of the arbitrary length data buffer,
                          // where x is the last index of the overall buffer
}
```

Where:

- Status (byte 0) indicates the status code of a given GenericSerialBus transaction.

- Length (byte 1) specifies the number of bytes of valid data that exists in the data buffer (bytes 2-x). Use of this field is only defined for the Read/Write Block protocol. For other protocols—where the data length is implied by the protocol—this field is reserved. Since this field is one byte, the maximum length of the data buffer is 255.
- Data (bytes 2-x) represents an arbitrary length buffer, and is the location where actual data is stored.

For example, the following ASL shows the use of the GenericSerialBus data buffer for performing transactions to a Smart Battery device.

```

/* Create the GenericSerialBus data buffer */

Name (BUFF, Buffer (34){})          // Create GenericSerialBus data buffer as BUFF
CreateByteField (BUFF, 0x00, STAT) // STAT = Status (Byte)
CreateByteField (BUFF, 0x01, LEN)  // LEN = Length (Byte)
CreateWordField (BUFF, 0x02, DATW) // DATW = Data (Word - Bytes 2 & 3)
CreateField (BUFF, 0x10, 256, DBUF) // DBUF = Data (Block - Bytes 2-33)

/* Read the battery temperature */

BUFF = BTMP // Invoke Read Word transaction

If (STAT == 0x00) // Successful?
{
    // DATW = Battery temperature in 1/10th degrees Kelvin
}

/* Read the battery manufacturer name */

BUFF = MFGN // Invoke Read Blocktransaction

If (STAT == 0x00) // Successful?
{
    // LEN = Length of the manufacturer name
    // DBUF = Manufacturer name (as a counted string)
}

```

Notice the use of the CreateField primitives to access the data buffer’s sub-elements (Status, Length, and Data), where Data (bytes 2-33) is ‘typecast’ as both word (DATW) and block (DBUF) data.

The example above demonstrates the use of the Store() operator to invoke a Read Block transaction to obtain the name of the battery manufacturer. Evaluation of the source operand (MFGN) results in a 34-byte buffer that gets copied by Store() to the destination buffer (BUFF).

Capturing the results of a write operation, for example to check the status code, requires an additional Store() operator, as shown below:

```

BUFF = (MFGN = BUFF)
If (STAT == 0x00) // Transaction successful?
{
    ...
}

```

Note that the outer Store() copies the results of the Write Block transaction back into BUFF. This is the nature of BufferAcc’s bi-directionality. It should be noted that storing (or parsing) the result of a GenericSerialBus Write transaction is not required although useful for ascertaining the outcome of a transaction.

GenericSerialBus Process Call protocols require similar semantics due to the fact that only destination operands are passed bi-directionally. These transactions require the use of the double-Store() semantics to properly capture the return results.

5.5.2.4.7.3 Using the GenericSerialBus Protocols

This section provides information and examples on how each of the GenericSerialBus protocols can be used to access GenericSerialBus devices from AML.

Read/Write Quick (AttribQuick)

The GenericSerialBus Read/Write Quick protocol (AttribQuick) is typically used to control simple devices using a device-specific binary command (for example, ON and OFF). Command values are not used by this protocol and thus only a single element (at offset 0) can be specified in the field definition. This protocol transfers no data.

The following ASL code illustrates how a device supporting the Read/Write Quick protocol should be accessed:

```

OperationRegion (TOP1, GenericSerialBus, 0x00, 0x100)
    // GenericSerialBus device at command value offset 0
Field (TOP1, BufferAcc, NoLock, Preserve)
{
    Connection (I2CSerialBusV2 (0x5a,,100000,, "\_SB.I2C",,,,,RawDataBuffer () {1,6})),
    AccessAs (BufferAcc, AttribQuick),
    FLD0, 8 // Use the GenericSerialBus Read/Write Quick protocol
            // Virtual register at command value 0.
}

/* Create the GenericSerialBus data buffer */

Name (BUFF, Buffer (2){}) // Create GenericSerialBus data buffer as BUFF
CreateByteField (BUFF, 0x00, STAT) // STAT = Status (Byte)

/* Signal device (e.g. OFF) */

BUFF = FLD0 // Invoke Read Quick transaction
If (STAT == 0x00) // Was the transactions successful?
{
    ...
}

/* Signal device (e.g. ON) */

FLD0 = FLD0 // Invoke Write Quick transaction

```

In this example, a single field element (FLD0) at offset 0 is defined to represent the protocol's read/write bit. Access to FLD0 will cause a GenericSerialBus transaction to occur to the device. Reading the field results in a Read Quick, and writing to the field results in a Write Quick. In either case data is not transferred—access to the register is simply used as a mechanism to invoke the transaction.

Send/Receive Byte (AttribSendReceive)

The GenericSerialBus Send/Receive Byte protocol (AttribSendReceive) transfers a single byte of data. Like Read/Write Quick, command values are not used by this protocol and thus only a single element (at offset 0) can be specified in the field definition.

The following ASL code illustrates how a device supporting the Send/Receive Byte protocol should be accessed:

```

OperationRegion (TOP1, GenericSerialBus, 0x00, 0x100)
    // GenericSerialBus device at command value offset 0
Field (TOP1, BufferAcc, NoLock, Preserve)
{
    Connection (I2CSerialBusV2 (0x5a,,100000,, "\_SB.I2C",,,,,RawDataBuffer () {1,6})),
    AccessAs (BufferAcc, AttribSendReceive),

```

(continues on next page)

(continued from previous page)

```

        // Use the GenericSerialBus Send/Receive Byte protocol
        FLD0, 8 // Virtual register at command value 0.
    }

// Create the GenericSerialBus data buffer

Name (BUFF, Buffer (3){}) // Create GenericSerialBus data buffer as BUFF
CreateByteField (BUFF, 0x00, STAT) // STAT = Status (Byte)
CreateByteField (BUFF, 0x02, DATA) // DATA = Data (Byte)

// Receive a byte of data from the device

BUFF = FLD0 // Invoke a Receive Byte transaction
If (STAT == 0x00) // Successful?
{
    // DATA = Received byte...
}

// Send the byte '0x16' to the device

DATA = 0x16 // Save 0x16 into the data buffer
FLD0 = BUFF //Invoke a Send Byte transaction

```

In this example, a single field element (FLD0) at offset 0 is defined to represent the protocol's data byte. Access to FLD0 will cause a GenericSerialBus transaction to occur to the device. Reading the field results in a Receive Byte, and writing to the field results in a Send Byte.

Read/Write Byte (AttribByte)

The GenericSerialBus Read/Write Byte protocol (AttribByte) also transfers a single byte of data. But unlike Send/Receive Byte, this protocol uses a command value to reference up to 256 byte-sized virtual registers.

The following ASL code illustrates how a device supporting the Read/Write Byte protocol should be accessed:

```

OperationRegion (TOP1, GenericSerialBus, 0x00, 0x100)
    // GenericSerialBus device at command value offset
Field (TOP1, BufferAcc, NoLock, Preserve)
{
    Connection (I2CSerialBusV2 (0x5a,,100000,, "\_SB.I2C",,,,,RawDataBuffer () {1,6})),
    AccessAs(BufferAcc, AttribByte), // Use the GenericSerialBus Read/Write Byte_
↪protocol
    FLD0, 8, // Virtual register at command value 0.
    FLD1, 8, // Virtual register at command value 1.
    FLD2, 8 // Virtual register at command value 2.
}

// Create the GenericSerialBus data buffer

Name (BUFF, Buffer (3){})

// Create GenericSerialBus data buffer as BUFF

CreateByteField (BUFF, 0x00, STAT) // STAT = Status (Byte)
CreateByteField (BUFF, 0x02, DATA) // DATA = Data (Byte)

// Read a byte of data from the device using command value 1

```

(continues on next page)

(continued from previous page)

```

BUFF = FLD1 // Invoke a Read Byte transaction
If (STAT == 0x00) // Successful?
{
    // DATA = Byte read from FLD1...
}

// Write the byte '0x16' to the device using command value 2

DATA = 0x16 // Save 0x16 into the data buffer
FLD2 = BUFF // Invoke a Write Byte transaction

```

In this example, three field elements (FLD0, FLD1, and FLD2) are defined to represent the virtual registers for command values 0, 1, and 2. Access to any of the field elements will cause a GenericSerialBus transaction to occur to the device. Reading FLD1 results in a Read Byte with a command value of 1, and writing to FLD2 results in a Write Byte with command value 2.

Read/Write Word (AttribWord)

The GenericSerialBus Read/Write Word protocol (AttribWord) transfers 2 bytes of data. This protocol also uses a command value to reference up to 256 word-sized virtual device registers.

The following ASL code illustrates how a device supporting the Read/Write Word protocol should be accessed:

```

OperationRegion (TOP1, GenericSerialBus, 0x00, 0x100)
    // GenericSerialBus device at command value offset 0
Field (TOP1, BufferAcc, NoLock, Preserve)
{
    Connection (I2CSerialBusV2 (0x5a,,100000,, "\_SB.I2C",,,,,RawDataBuffer () {1,6})),
    AccessAs (BufferAcc, AttribWord),
    // Use the GenericSerialBus Read/Write Word protocol
    FLD0, 8, // Virtual register at command value 0.
    FLD1, 8, // Virtual register at command value 1.
    FLD2, 8 // Virtual register at command value 2.
}

// Create the GenericSerialBus data buffer

Name (BUFF, Buffer (6) {}) // Create GenericSerialBus data buffer as BUFF
CreateByteField (BUFF, 0x00, STAT) // STAT = Status (Byte)
CreateWordField (BUFF, 0x02, DATA) // DATA = Data (Word)

/* Read two bytes of data from the device using command value 1 */

BUFF = FLD1 // Invoke a Read Word transaction
If (STAT == 0x00) // Was the transaction successful?
{
    // DATA = Word read from FLD1...
}

/* Write the word '0x5416' to the device using command value 2 */

DATA = 0x5416 // Save 0x5416 into the data buffer
FLD2 = BUFF // Invoke a Write Word transaction

```

In this example, three field elements (FLD0, FLD1, and FLD2) are defined to represent the virtual registers for command values 0, 1, and 2. Access to any of the field elements will cause a GenericSerialBus transaction to occur to the device. Reading FLD1 results in a Read Word with a command value of 1, and writing to FLD2 results in a Write Word with command value 2.

Notice that although accessing each field element transmits a word (16 bits) of data, the fields are listed as 8 bits each. The actual data size is determined by the protocol. Every field element is declared with a length of 8 bits so that command values and byte offsets are equivalent.

Read/Write Block (AttribBlock)

The GenericSerialBus Read/Write Block protocol (AttribBlock) transfers variable-sized data. This protocol uses a command value to reference up to 256 block-sized virtual registers.

The following ASL code illustrates how a device supporting the Read/Write Block protocol should be accessed:

```

OperationRegion (TOP1, GenericSerialBus, 0x00, 0x100)
Field (TOP1, BufferAcc, NoLock, Preserve)
{
    Connection (I2CSerialBusV2 (0x5a,,100000,, "\_SB.I2C",,,,,RawDataBuffer() {1,6})),
    Offset (0x0),
    AccessAs (BufferAcc, AttribBlock),
    TFK1, 8,
    TFK2, 8
}

// Create the GenericSerialBus data buffer
Name (BUFF, Buffer (34){}) // Create SerialBus buf as BUFF
CreateByteField (BUFF, 0x00, STAT) // STAT = Status (Byte)
CreateBytefield (BUFF, 0x01, LEN) // LEN = Length (Byte)
CreateWordField (BUFF, 0x03, DATW) // DATW = Data (Word - Bytes 2 & 3, or 16 bits)
CreateField (BUFF, 16, 256, DBUF) // DBUF = Data (Bytes 2-33)
CreateField (BUFF, 16, 32, DATD) // DATD = Data (DWord)

/* Read block of data from the device using command value 0 */
BUFF = TFK1
If (STAT != 0x00)
{
    Return (0)
}

/* Read block of data from the device using command value 1 */
BUFF = TFK2
If (STAT != 0x00)
{
    Return (0)
}

```

In this example, two field elements (TFK1, and TFK2) are defined to represent the virtual registers for command values 0 and 1. Access to any of the field elements will cause a GenericSerialBus transaction to occur to the device.

Writing blocks of data requires similar semantics, such as in the following example:

```

Store (16, LEN) // In bits, so 4 bytes
LEN = 16
BUFF = (TFK1 = BUFF)
If (STAT == 0x00) // Was the transaction successful?
{
    ...
}

```

This accessor is not viable for some SPBs because the bus may not support the appropriate functionality. In cases that

variable length buffers are desired but the bus does not support block accessors, refer to the SerialBytes protocol.

Word Process Call (AttribProcessCall)

The GenericSerialBus Process Call protocol (AttribProcessCall) transfers 2 bytes of data bi-directionally (performs a Write Word followed by a Read Word as an atomic transaction). This protocol uses a command value to reference up to 256 word-sized virtual registers.

The following ASL code illustrates how a device supporting the Process Call protocol should be accessed:

```

OperationRegion (TOP1, GenericSerialBus, 0x00, 0x100)
    // GenericSerialBus device at slave address 0x42
Field (TOP1, BufferAcc, NoLock, Preserve)
{
    Connection (I2CSerialBusV2 (0x5a,,100000,, "\_SB.I2C",,,,,RawDataBuffer(){1,6})),
    AccessAs (BufferAcc, AttribProcessCall),
    // Use the GenericSerialBus Process Call protocol
    FLD0, 8, // Virtual register at command value 0.
    FLD1, 8, // Virtual register at command value 1.
    FLD2, 8 // Virtual register at command value 2.
}

// Create the GenericSerialBus data buffer

Name (BUFF, Buffer (6){}) // Create GenericSerialBus data buffer as BUFF
CreateByteField (BUFF, 0x00, STAT) // STAT = Status (Byte)
CreateWordField (BUFF, 0x02, DATA) // DATA = Data (Word)

/* Process Call with input value '0x5416' to the device using command value 1 */

DATA = 0x5416 // Save 0x5416 into the data buffer

BUFF = (FLD1 = BUFF) // Invoke a Process Call transaction
If (STAT == 0x00) // Was the transaction successful?
{
    // DATA = Word returned from FLD1...
}

```

In this example, three field elements (FLD0, FLD1, and FLD2) are defined to represent the virtual registers for command values 0, 1, and 2. Access to any of the field elements will cause a GenericSerialBus transaction to occur to the device. Reading or writing FLD1 results in a Process Call with a command value of 1. Notice that unlike other protocols, Process Call involves both a write and read operation in a single atomic transaction. This means that the Data element of the GenericSerialBus data buffer is set with an input value before the transaction is invoked, and holds the output value following the successful completion of the transaction.

Block Process Call (AttribBlockProcessCall)

The GenericSerialBus Block Write-Read Block Process Call protocol (AttribBlockProcessCall) transfers a block of data bi-directionally (performs a Write Block followed by a Read Block as an atomic transaction). This protocol uses a command value to reference up to 256 block-sized virtual registers.

The following ASL code illustrates how a device supporting the Process Call protocol should be accessed:

```

OperationRegion (TOP1, GenericSerialBus, 0x00, 0x100)
    // GenericSerialBus device at slave address 0x42
Field (TOP1, BufferAcc, NoLock, Preserve)
{
    Connection (I2CSerialBusV2 (0x5a,,100000,, "\_SB.I2C",,,,,RawDataBuffer(){1,6})),
    AccessAs (BufferAcc, AttribBlockProcessCall),

```

(continues on next page)

(continued from previous page)

```

// Use the Block Process Call protocol
FLD0, 8, // Virtual register representing a command value of 0
FLD1, 8 // Virtual register representing a command value of 1
}

// Create the GenericSerialBus data buffer as BUFF

Name (BUFF, Buffer (35){}) // Create GenericSerialBus data buffer as BUFF
CreateByteField (BUFF, 0x00, STAT) // STAT = Status (Byte)
CreateByteField (BUFF, 0x01, LEN) // LEN = Length (Byte)
CreateField (BUFF, 0x10, 256, DATA) // Data (Block)

/* Process Call with input value "ACPI" to the device using command value 1 */

DATA = "ACPI" // Fill in outgoing data
LEN = 4 // Length of the valid data not including status (STAT)
// and length (LEN) bytes.
BUFF = (FLD1 = BUFF)

If (STAT == 0x00) // Test the status
{
// BUFF now contains information returned from PC
// LEN now equals size of data returned
}

```

Read/Write N Bytes (AttribBytes)

The GenericSerialBus Read/Write N Bytes protocol (AttribBytes) transfers variable-sized data. The read transfer byte length of the bi-directional call specified as a part of the AccessAs attribute.

The following ASL code illustrates how a device supporting the Read/Write N Bytes protocol should be accessed:

```

OperationRegion (TOP1, GenericSerialBus, 0x00, 0x100)
Field (TOP1, BufferAcc, NoLock, Preserve)
{
    Connection (I2CSerialBusV2 (0x5a,,100000,, "\\_SB.I2C",,,,,RawDataBuffer() {1,6})),
    AccessAs (BufferAcc, AttribBytes (4)),
    TFK1, 8, //TFK1 at command value 0
    TFK2, 8, //TFK2 at command value 1
    Connection (I2CSerialBus (0x5b,,100000,, "\\_SB.I2C",,,,,RawDataBuffer () {2,9})),
    // same connection attribute, but different vendor data passed to driver
    AccessAs (BufferAcc, AttribByte),
    TM1, 8 //TM1 at command value 2
}

// Create the GenericSerialBus data buffer

Name (BUFF, Buffer(34) {}) // Create SerialBus buf as BUFF
CreateByteField (BUFF, 0x00, STAT) // STAT = Status (Byte)
CreateBytefield (BUFF, 0x01, LEN) // LEN = Length (Byte)
CreateWordField (BUFF, 0x02, DATW) // DATW = Data (Word - Bytes 2 & 3, or 16 bits)
CreateField (BUFF, 16, 256, DBUF) // DBUF = Data (Bytes 2-34)
CreateField (BUFF, 16, 32, DATD) // DATD = Data (DWord)

// Read block of data from the device using command value 0

BUFF = TFK1

```

(continues on next page)

(continued from previous page)

```

If (STAT != 0x00)
{
    Return (0)
}

// Write block of data to the device using command value 1

BUFF = (TFK2 = BUFF)
If (STAT != 0x00)
{
    Return (0)
}

```

In this example, two field elements (TFK1, and TFK2) are defined to represent the virtual registers for command values 0 and 1. Access to any of the field elements will cause a GenericSerialBus transaction to occur to the device of the length specified in the AccessAttributes.

Raw Read/Write N Bytes (AttribRawBytes)

The GenericSerialBus Raw Read/Write N Bytes protocol (AttribRawBytes) transfers variable-sized data. The read transfer byte length of the bi-directional transaction specified as a part of the AccessAs attribute. The initial command value specified in the operation region definition is ignored by Raw accesses.

The following ASL code illustrates how a device supporting the Read/Write N Bytes protocol should be accessed:

```

OperationRegion (TOP1, GenericSerialBus, 0x00, 0x100)
Field (TOP1, BufferAcc, NoLock, Preserve)
{
    Connection (I2CSerialBusV2 (0x5a,,100000,, "\\_SB.I2C",,,,,RawDataBuffer() {1,6})),
    AccessAs(BufferAcc, AttribRawBytes (4)),
    TFK1, 8
}

/* Create the GenericSerialBus data buffer */

Name(BUFF, Buffer (34){}) // Create SerialBus buf as BUFF
CreateByteField (BUFF, 0x00, STAT) // STAT = Status (Byte)
CreateByteField (BUFF, 0x01, LEN) // LEN = Length (Byte)
CreateWordField (BUFF, 0x02, DATW) // DATW = Data (Word - Bytes 2 & 3, or 16 bits)
CreateField (BUFF, 16, 256, DBUF) // DBUF = Data (Bytes 2-34)
CreateField (BUFF, 16, 32, DATD) // DATD = Data (DWord)

DATW = 0x0B // Store appropriate reference data for driver to interpret

/* Read from TFK1 */

BUFF = TFK1
If (STAT != 0x00)
{
    Return (0)
}

/* Write to TFK1 */

BUFF = (TFK1 = BUFF)
If (STAT != 0x00)
{

```

(continues on next page)

(continued from previous page)

```

Return(0)
}

```

Access to any field elements will cause a GenericSerialBus transaction to occur to the device of the length specified in the AccessAttributes.

Raw accesses assume that the writer has knowledge of the bus that the access is made over and the device that is being accessed. The protocol may only ensure that the buffer is transmitted to the appropriate driver, but the driver must be able to interpret the buffer to communicate to a register.

Raw Block Process Call (AttribRawProcessBytes)

The GenericSerialBus Raw Write-Read Block Process Call protocol (AttribRawProcessBytes) transfers a block of data bi-directionally (performs a Write Block followed by a Read Block as an atomic transaction). The read transfer byte length of the bi-directional transaction specified as a part of the AccessAs attribute. The initial command value specified in the operation region definition is ignored by Raw accesses.

The following ASL code illustrates how a device supporting the Process Call protocol should be accessed:

```

OperationRegion (TOP1, GenericSerialBus, 0x00, 0x100)
    // GenericSerialBus device at slave address 0x42
Field (TOP1, BufferAcc, NoLock, Preserve)
{
    Connection (I2CSerialBusV2 (0x5a,,100000,, "\_SB.I2C",,,,,RawDataBuffer () {1,6})),
    AccessAs (BufferAcc, AttribRawProcessBytes (2)),
    // Use the Raw Bytes Process Call protocol
    FLD0, 8
}

// Create the GenericSerialBus data buffer as BUFF

Name (BUFF, Buffer (34){}) // Create GenericSerialBus data buffer as BUFF
CreateByteField (BUFF, 0x00, STAT) // STAT = Status (Byte)
CreateByteField (BUFF, 0x01, LEN) // LEN = Length (Byte)
CreateWordField (BUFF,0x02, DATW) // Data (Bytes 2 and 3)
CreateField (BUFF, 0x10, 256, DATA) // Data (Block)

DATW = 0x0B //Store appropriate reference data for driver to interpret

/* Process Call with input value "ACPI" to the device */

DATA = "ACPI" // Fill in outgoing data
LEN = 4 // Length of the valid data

BUFF = (FLD0 = BUFF) // Execute the PC
If (STAT == 0x00) // Test the status
{
    // BUFF now contains information returned from PC
    // LEN now equals size of data returned
}

```

Raw accesses assume that the writer has knowledge of the bus that the access is made over and the device that is being accessed. The protocol may only ensure that the buffer is transmitted to the appropriate driver, but the driver must be able to interpret the buffer to communicate to a register.

5.5.2.4.8 Declaring PCC Operation Regions

The Platform Communication Channel (PCC) is described in Chapter 14. The PCC table, described in *Platform Communications Channel Table*, contains information about PCC subspaces implemented in a given platform, where each subspace is a unique channel.

5.5.2.4.8.1 Overview

The PCC Operation Region works in conjunction with the PCC Table (*Platform Communications Channel Table*). The PCC Operation Region is associated with the region of the shared memory that follows the PCC signature. PCC Operation Region must not be used for extended subspaces of Type 4 (Responder subspaces). PCC subspaces that are earmarked for use as PCC Operation Regions must not be used as PCC subspaces for standard ACPI features such as CPPC, RASF, PDTT and MPST. These standard features must always use the PCC Table instead.

5.5.2.4.8.2 Declaring a PCC OperationRegion

The syntax for the OperationRegion term (*OperationRegion (Declare Operation Region)*) is described below:

```
OperationRegion (
    RegionName,    // NameString
    RegionSpace,  // RegionSpaceKeyword
    Offset,        // TermArg=>Integer
    Length        // TermArg=>Integer
)
```

The PCC Operation Region term in ACPI namespace will be defined as follows:

```
OperationRegion ([subspace-name], PCC, [subspace-id], Length)
```

Where:

- RegionName is set to *[subspace-name]*, which is a unique name for this PCC subspace.
- RegionSpace must be set to PCC, operation region type 0x0A
- Offset must be set to *[subspace-id]*, the subspace ID of this channel, as defined in the PCC table (PCCT).
- Length is the total size of the operation region, and is equal to the total size of the fields that succeed the PCC signature in the shared memory.

5.5.2.4.8.3 Declaring message fields within a PCC OperationRegion

For all PCC subspace types, the PCC Operation Region pertains to the region of PCC subspace that succeeds the PCC signature. The layout of the Shared Memory Regions is specific to the PCC subspace. The Operation Region handler must therefore obtain the subspace type first before it can comprehend and access individual fields within the subspace.

Fields within an Operation region are accessed using the Field keyword, and correspond to the fields that succeed the PCC signature in the subspace shared memory. The syntax for the Field term (from *Field (Declare Field Objects)*) is as follows:

```
Field (
    RegionName,
    AccessType,
    LockRule,
```

(continues on next page)

(continued from previous page)

```
UpdateRule
) {FieldUnitList}
```

For PCC Operation Regions:

- RegionName specifies the name of the operation region, declared above the field term.
- AccessType must be set to ByteAcc.
- LockRule indicates if access to this operation region requires acquisition of the Global lock for synchronization. This field must be set to NoLock.
- UpdateRule is not applicable to PCC operation regions, since each command region is accessed in its entirety.

The FieldUnitList specifies individual fields within the Shared Memory Region of the subspace, which depends on the type of subspace. The declaration of the fields must match the layout of the subspace. Accordingly, for the Generic Communications subspaces (Types 0-2), the *FieldUnitList* may be declared as follows:

```
Field(NAME, ByteAcc, NoLock, Preserve)
{
  CMD, 16,      // Command field
  STAT, 16,    // Status field, to be read on completion of the command
  DATA, [Size] // Communication space of size [Size] bits
}
```

Likewise, for the Extended Communication subspaces (Type 3), the *FieldUnitList* may be declared as follows:

```
Field(NAME, ByteAcc, NoLock, Preserve)
{
  FLGS, 32,    // Command Flags field
  LEN, 32,    // Length field
  CMD, 32,    // Command field
  DATA, [Size] // Communication space of size [Size] bits
}
```

5.5.2.4.8.4 An Example of PCC Operation Region Declaration

As an example, if a platform feature uses PCC subspace with subspace ID of 0x02 of subspace Type 3 (Extended PCC communication channel), then the caller may declare the operation region as follows:

```
OperationRegion(PFRM, PCC, 0x02, 0x10C)
Field(PFRM, ByteAcc, NoLock, Preserve)
{
  Offset (4), // Flags start at offset 4 from beginning of shared memory
  FLGS, 32,  // Command Flags field
  LGTH, 32,  // Length field
  COMD, 32,  // Command field
  COSP, 0x800 // Communication space of size 256 bytes
}
```

In this example, PFRM is the name of the subspace dedicated to the platform feature, and the size of the shared memory region is 0x10C bytes (256 bytes of communication space and 16 bytes of fields excluding the PCC Signature).

5.5.2.4.8.5 Using a PCC OperationRegion

The PCC Operation Region handler begins transmission of the message on the channel when it detects a write to the CMD field. The caller must therefore update all other fields relevant to the operation region first, and then in the final step, write the command itself. As explained in *Declaring message fields within a PCC OperationRegion*, the fields to be updated are specific to the subspace type.

For the Generic Communication subspace type (Types 0, 1 and 2), the order of Operation Region writes would be as follows:

1. Write the command payload into the DATA field. StepNumList-1 Write the command payload into the DATA field.
2. Write the command into the CMD field.

For the Extended Communication subspace type (Type 3), the order of Operation Region writes would be as follows:

1. Write the command payload, length and flags into the CMD, LEN and FLGS fields, respectively, in any order of preference. StepNumList-1 Write the command payload, length and flags into the CMD, LEN and FLGS fields, respectively, in any order of preference.
2. Write the command into the CMD field.

In the above steps, the fields are as described in [Section 5.5.2.4.8.4](#). When the platform completes processing the command, it uses the same subspace Shared Memory Region to return the response data. The caller can thus read the Operation Region to retrieve the response data.

If channel errors are encountered during transmission of the command or its response, the channel reports an error status in the Channel Status register. The caller must therefore first check the Channel Status register before processing the return data. For the Generic PCC Communication Subspaces, the Channel Status register is located in the Shared Memory Region itself, as described in *Generic Communications Channel Status Field*. The caller must thus check the STAT field in the Operation Region for the purpose. For the Extended PCC Communication Subspaces, the Channel Status register is located anywhere in system memory or IO, and pointed to by the Error Status register field within the Type 3 PCC Subspace structure, as described in *Extended PCC subspaces (types 3 and 4)*.

5.5.2.4.8.6 Using the _REG Method for PCC Operation Regions

It is possible for the OS to include PCC operation region handlers that only comprehend and support a subset of the possible subspaces defined in this specification. The OS can provide supplementary information in the _REG method in order to indicate which exact subspaces(s) are supported. To accomplish this, the Arg0 parameter passed to the _REG method must include both the Address Space ID (PCC) and a qualifying Address Space sub-type in Byte 1, as follows:

Arg0, Byte 0 = PCC = 0x0A Arg0, Byte 1 = subspace type as defined in [Section 14.1.2](#).

The OS may now indicate support for handling PCC operation region subspace Type 3 by invoking the _REG method with Arg0=0x030A and Arg1 = 0x01.

5.5.2.4.8.7 Example Use of a PCC OperationRegion

The following sample ACPI Power Meter (*Power Meters*) implementation describes how a PCC Operation Region can be used to read a platform power sensor that is exposed through a platform services channel. In this sample system, the platform services channel is implemented as an Extended PCC Communication Channel (Type 3), and assigned a PCC subspace ID of 0x07 in the PCCT. The sample platform implements three sensors - two power sensors, associated with CPU cluster 0 and cluster 1 respectively, and a SoC-level thermal sensor. The power sensors are read using command 0x15 (READ_POWER_SENSOR), while the thermal sensor is read using command 0x16 (READ_THERMAL_SENSOR), both on the platform services channel. The READ_POWER_SENSOR command take two input parameters called SensorInstance and MeasurementFormat, which are appended together to the command as the payload. SensorInstance specifies which power sensor is being referenced. MeasurementFormat specifies the measurement unit (watts or milliwatts) in which the power consumption is expressed. The command payload is thus formatted as follows:

```
typedef struct
{
    BYTE SensorInstance;    // Which instance of the sensor is being read
    BYTE MeasurementFormat; // 0 = mW, 1 = W
} COMMAND_PAYLOAD;
```

The power sensor for CPU cluster 0 is read by setting SensorInstance to 0x01, while the power sensor for CPU cluster 1 is read by setting SensorInstance to 0x02.

The response to the command from the platform is of the form:

```
typedef struct
{
    DWORD Reading;    // The sensor value read
    DWORD Status;    // Status of the operation - 0: success, non-zero: error
} SENSOR_RESPONSE;
```

Here, the field Status pertains to the success or failure of the requested service. Channel errors can occur independent of the service, during transmission of the request. A generic placeholder register, CHANNEL_STATUS_REG, and an associated error status field, ERROR_STATUS_BIT, is used as an illustration of how the channel status register may be read to detect channel errors during transit.

The ACPI Power Meter object may now be implemented for this example platform as follows:

```
Device (PMT0) // ACPI Power Meter object for CPU Cluster 0 Power Sensor
{
    Name (_HID, "ACPI000D") // ACPI Power Meter device

    // The Operation Region declaration, based on "An Example of PCC Operation
    // Region Declaration" described earlier in this chapter.

    OperationRegion (PFRM, PCC, 0x07, 0x8C)
    Field(PFRM, ByteAcc, NoLock, Preserve)
    {
        FLGS, 32, // Command Flags field
        LEN, 32, // Length field
        CMD, 32, // Command field
        DATA, 0x400 // Communication space of size 128 bytes
    }

    Method (_REG, 2) // Check if OS Op region handler is available
    {
        /*
```

(continues on next page)

(continued from previous page)

```

    * Check if Arg0.Byte0 = 0xA, PCC Operation Region Supported?
    * Check if Arg0.Byte1 = 0x3, subchannel type 3 as defined in Table 14-357
    * Disallow further processing until support for Type 3 becomes available
    */
}

// Read a Power sensor
Method (_PMM, 0, Serialized)
{
    // Create the command buffer

    Name(BUFF, Buffer(0x80){}) // Create PCC data buffer as BUFF
    Name(PAYL, Buffer(2) {0x02, 0x01}) // Instance = CPU cluster 1

    // Read power in units of Watts

    DATA = PAYL // Only first two bytes written, the rest default to 0

    // Update the length and status fields

    LEN = 0x06 // 4B (command) + 2B (payload)
    FLGS = 0x01 // Set Notify on Completion

    /*
    * All done. Now write to the command field to begin transmission of
    * the message over the PCC subspace. On receipt, the platform will
    * read power sensor of CPU cluster 0 and return the power consumption
    * reading in the Operation Region itself
    */
    CMD = 0x15 // READ_POWER_SENSOR command = 0x15

    If(LEqual( LAnd (CHANNEL_STATUS_REG, ERROR_STATUS_BIT), 0x01)
    {
        Return (Ones). // Return invalid, so that the caller can take remedial_
↪steps
    }

    BUFF = DATA
    CreateDWordField(BUFF, 0x00, PCL1) // Power consumed by CPU cluster 1
    CreateDWordField(BUFF, 0x01, STAT) // Return status
    If (STAT == 0x0) // Successful?
    {
        Return (PCL1) // Return the power measurement for CPU cluster 1
    }
    Else
    {
        Return (Ones) // Return invalid
    }
}
}

```

5.6 ACPI Event Programming Model

The ACPI event programming model is based on the SCI interrupt and General-Purpose Event (GPE) register. ACPI provides an extensible method to raise and handle the SCI interrupt, as described in this section.

Hardware-Reduced ACPI platforms use *GPIO-signaled ACPI Events*, or *Interrupt-signaled ACPI events*. Note that any ACPI platform may utilize GPIO-signaled and/or Interrupts-signaled ACPI events (in other words, these events are not limited to Hardware-reduced ACPIvplatforms).

5.6.1 ACPI Event Programming Model Components

The components of the ACPI event programming model are the following:

- OSPM
- FADT
- PM1a_STS, PM1b_STS and PM1a_EN, PM1b_EN fixed register blocks
- GPE0_BLK and GPE1_BLK register blocks
- GPE register blocks defined in GPE block devices
- SCI interrupt
- ACPI AML code general-purpose event model
- ACPI device-specific model events
- ACPI Embedded Controller event model

The role of each component in the ACPI event programming model is described in the following table.

Table 5.185: ACPI Event Programming Model Components

Component	Description
OSPM	Receives all SCI interrupts raised (receives all SCI events). Either handles the event or masks the event off and later invokes an OEM-provided control method to handle the event. Events handled directly by OSPM are fixed ACPI events; interrupts handled by control methods are general-purpose events.
FADT	Specifies the base address for the following fixed register blocks on an ACPI-compatible platform: PM1x_STS and PM1x_EN fixed registers and the GPEx_STS and GPEx_EN fixed registers.
PM1x_STS and PM1x_EN fixed registers	PM1x_STS bits raise fixed ACPI events. While a PM1x_STS bit is set, if the matching PM1x_EN bit is set, the ACPI SCI event is raised.
GPEx_STS and GPEx_EN fixed registers	GPEx_STS bits that raise general-purpose events. For every event bit implemented in GPEx_STS, there must be a comparable bit in GPEx_EN. Up to 256 GPEx_STS bits and matching GPEx_EN bits can be implemented. While a GPEx_STS bit is set, if the matching GPEx_EN bit is set, then the general-purpose SCI event is raised.
SCI interrupt	A level-sensitive, shareable interrupt mapped to a declared interrupt vector. The SCI interrupt vector can be shared with other low-priority interrupts that have a low frequency of occurrence.

continues on next page

Table 5.185 – continued from previous page

Component	Description
ACPI AML code general-purpose event model	A model that allows OEM AML code to use GPE _x _STS events. This includes using GPE _x _STS events as “wake” sources as well as other general service events defined by the OEM (“button pressed,” “thermal event,” “device present/not present changed,” and so on).
ACPI device-specific model events	Devices in the ACPI namespace that have ACPI-specific device IDs can provide additional event model functionality. In particular, the ACPI embedded controller device provides a generic event model.
ACPI Embedded Controller event model	A model that allows OEM AML code to use the response from the Embedded Controller Query command to provide general-service event defined by the OEM.

5.6.2 Types of ACPI Events

At the ACPI hardware level, two types of events can be signaled by an SCI interrupt:

- Fixed ACPI events
- General-purpose events

In turn, the general-purpose events can be used to provide further levels of events to the system. And, as in the case of the embedded controller, a well-defined second-level event dispatching is defined to make a third type of typical ACPI event. For the flexibility common in today’s designs, two first-level general-purpose event blocks are defined, and the embedded controller construct allows a large number of embedded controller second-level event-dispatching tables to be supported. Then if needed, the OEM can also build additional levels of event dispatching by using AML code on a general-purpose event to sub-dispatch in an OEM defined manner.

5.6.3 Fixed Event Handling

When OSPM receives a fixed ACPI event, it directly reads and handles the event registers itself. The following table lists the fixed ACPI events. For a detailed specification of each event, see the *ACPI Hardware Specification*

Table 5.186: Fixed ACPI Events

Event	Comment
Power management timer carry bit set.	For more information, see the description of the TMR_STS and TMR_EN bits of the PM1x fixed register block in <i>PM1 Event Grouping</i>
Power button signal	A power button can be supplied in two ways. One way is to simply use the fixed status bit, and the other uses the declaration of an ACPI power device and AML code to determine the event. For more information about the alternate-device based power button, see <i>Control Method Power Button</i> . Notice that during the S0 state, both the power and sleep buttons merely notify OSPM that they were pressed. If the system does not have a sleep button, it is recommended that OSPM use the power button to initiate sleep operations as requested by the user.
Sleep button signal	A sleep button can be supplied in one of two ways. One way is to simply use the fixed status button. The other way requires the declaration of an ACPI sleep button device and AML code to determine the event.

continues on next page

Table 5.186 – continued from previous page

Event	Comment
RTC alarm	ACPI-defines an RTC wake alarm function with a minimum of one-month granularity. The ACPI status bit for the device is optional. If the ACPI status bit is not present, the RTC status can be used to determine when an alarm has occurred. For more information, see the description of the RTC_STS and RTC_EN bits of the PM1x fixed register block in <i>PM1 Event Grouping</i>
Wake status	The wake status bit is used to determine when the sleeping state has been completed. For more information, see the description of the WAK_STS and WAK_EN bits of the PM1x fixed register block in <i>PM1 Event Grouping</i>
System bus master request	The bus-master status bit provides feedback from the hardware as to when a bus master cycle has occurred. This is necessary for supporting the processor C3 power savings state. For more information, see the description of the BM_STS bit of the PM1x fixed register block in <i>PM1 Event Grouping</i>
Global Release Status	This status is raised as a result of the Global Lock protocol, and is handled by OSPM as part of Global Lock synchronization. For more information, see the description of the GBL_STS bit of the PM1x fixed register block in <i>PM1 Event Grouping</i> .

5.6.4 General-Purpose Event Handling

When OSPM receives a general-purpose event, it either passes control to an ACPI-aware driver, or uses an OEM-supplied control method to handle the event. An OEM can implement up to 128 general-purpose event inputs in hardware per GPE block, each as either a level or edge event. It is also possible to implement a single 256-pin block as long as it's the only block defined in the system.

An example of a general-purpose event is specified in *ACPI Hardware Specification* where EC_STS and EC_EN bits are defined to enable OSPM to communicate with an ACPI-aware embedded controller device driver. The EC_STS bit is set when either an interface in the embedded controller space has generated an interrupt or the embedded controller interface needs servicing. Notice that if a platform uses an embedded controller in the ACPI environment, then the embedded controller's SCI output must be directly and exclusively tied to a single GPE input bit.

Hardware can cascade other general-purpose events from a bit in the GPEX_BLK through status and enable bits in Operational Regions (I/O space, memory space, PCI configuration space, or embedded controller space). For more information, see the specification of the General-Purpose Event Blocks (GPEX_BLK) in *General-Purpose Event Register Blocks*

OSPM manages the bits in the GPEX blocks directly, although the source to those events is not directly known and is connected into the system by control methods. When OSPM receives a general-purpose event (the event is from either a GPEX_BLK STS bit, a GPIO pin, or an Interrupt), OSPM does the following:

1. Disables the interrupt source
2. (GPEX_BLK EN bit): GPIO interrupt for GPIO-signaled events. | Interrupt for Interrupt-signaled events. | If an edge event, clears the status bit.
3. Performs one of the following: Dispatches to an ACPI-aware device driver. | Queues the matching control method for execution. | Manages a wake event using device _PRW objects.
4. If a level event, waits for the control method handler to complete and clears the status bit.
5. Enables the interrupt source.

For OSPM to manage the bits in the GPEX_BLK blocks directly:

- Enable bits must be read/write.
- Status bits must be latching.
- Status bits must be read/clear, and cleared by writing a “1” to the status bit.

5.6.4.1 `_Exx`, `_Lxx`, and `_Qxx` Methods for GPE Processing

The OEM AML code can perform OEM-specific functions custom to each event the particular platform might generate by executing a control method that matches the event. For GPE events, OSPM will execute the control method of the name `_GPE._TXX` where `XX` is the hex value format of the event that needs to be handled and `T` indicates the event handling type (`T` must be either ‘E’ for an edge event or ‘L’ for a level event). The event values for status bits in `GPE0_BLK` start at zero (`_T00`) and end at the $(GPE0_BLK_LEN / 2) - 1$. The event values for status bits in `GPE1_BLK` start at `GPE1_BASE` and end at `GPE1_BASE + (GPE1_BLK_LEN / 2) - 1`. `GPE0_BLK_LEN`, `GPE1_BASE`, and `GPE1_BLK_LEN` are all defined in the FADT.

The `_Qxx` methods are used for the Embedded Controller and SMBus (see below).

5.6.4.1.1 Queuing the Matching Control Method for Execution

When a general-purpose event is raised, OSPM uses a naming convention to determine which control method to queue for execution and how the GPE EOI is to be handled. The `GPEx_STS` bits in the `GPEx_BLK` are indexed with a number from 0 through FF. The name of the control method to queue for an event raised from an enable status bit is always of the form `_GPE._Txx` where `xx` is the event value and `T` indicates the event EOI protocol to use (either ‘E’ for edge triggered, or ‘L’ for level triggered). The event values for status bits in `GPE0_BLK` start at zero (`_T00`), end at the $(GPE0_BLK_LEN / 2) - 1$, and correspond to each status bit index within `GPE0_BLK`. The event values for status bits in `GPE1_BLK` are offset by `GPE_BASE` and therefore start at `GPE1_BASE` and end at `GPE1_BASE + (GPE1_BLK_LEN / 2) - 1`.

For example, suppose an OEM supplies a wake event for a communications port and uses bit 4 of the `GPE0_STS` bits to raise the wake event status. In an OEM-provided Definition Block, there must be a Method declaration that uses the name `_GPE._L04` or `\GPE._E04` to handle the event. An example of a control method declaration using such a name is the following:

```
Method (\_GPE._L04) { // GPE 4 level wake handler
    Notify (\_SB.PCI0.COM0, 2)
}
```

The control method performs whatever action is appropriate for the event it handles. For example, if the event means that a device has appeared in a slot, the control method might acknowledge the event to some other hardware register and signal a change notify request of the appropriate device object. Or, the cause of the general-purpose event can result from more than one source, in which case the control method for that event determines the source and takes the appropriate action.

When a general-purpose event is raised from the GPE bit tied to an embedded controller, the embedded controller driver uses another naming convention defined by ACPI for the embedded controller driver to determine which control method to queue for execution. The queries that the embedded controller driver exchanges with the embedded controller are numbered from 0 through FF, yielding event codes 01 through FF. (A query response of 0 from the embedded controller is reserved for “no outstanding events.”) The name of the control method to queue is always of the form `_Qxx` where `xx` is the number of the query acknowledged by the embedded controller. An example declaration for a control method that handles an embedded controller query is the following:

```
Method(_Q34) { // embedded controller event for thermal
    Notify (\_SB.TZ0.THML, 0x80)
}
```

When an SMBus alarm is handled by the SMBus driver, the SMBus driver uses a similar naming convention defined by ACPI for the driver to determine the control method to queue for execution. When an alarm is received by the SMBus host controller, it generally receives the SMBus address of the device issuing the alarm and one word of data. On implementations that use SMBALERT# for notifications, only the device address will be received. The name of the control method to queue is always of the form `_Qxx` where `xx` is the SMBus address of the device that issued the alarm. The SMBus address is 7 bits long corresponding to hex values 0 through 7F, although some addresses are reserved and will not be used. The control method will always be queued with one argument that contains the word of data received with the alarm. An exception is the case of an SMBus using SMBALERT# for notifications, in this case the argument will be 0. An example declaration for a control method that handles a SMBus alarm follows:

```
Method(_Q18, 1) { // Thermal sensor device at address 001 1000
                  // Arg0 contains notification value (if any)
                  // Arg0 = 0 if device supports only SMBALERT#
    Notify (\_SB.TZ0.THML, 0x80)
}
```

5.6.4.1.2 Dispatching to an ACPI-Aware Device Driver

Certain device support, such as an embedded controller, requires a dedicated GPE to service the device. Such GPEs are dispatched to native OS code to be handled and not to the corresponding GPE-specific control method.

In the case of the embedded controller, an OS-native, ACPI-aware driver is given the GPE event for its device. This driver services the embedded controller device and determines when events are to be reported by the embedded controller by using the Query command. When an embedded controller event occurs, the ACPI-aware driver dispatches the requests to other ACPI-aware drivers that have registered to handle the embedded controller queries or queues control methods to handle each event. If there is no device driver to handle specific queries, OEM AML code can perform OEM-specific functions that are customized to each event on the particular platform by including specific control methods in the namespace to handle these events. For an embedded controller event, OSPM will queue the control method of the name `_QXX`, where `XX` is the hex format of the query code. Notice that each embedded controller device can have query event control methods.

Similarly, for an SMBus driver, if no driver registers for SMBus alarms, the SMBus driver will queue control methods to handle these. Methods must be placed under the SMBus device with the name `_QXX` where `XX` is the hex format of the SMBus address of the device sending the alarm.

5.6.4.2 GPE Wake Events

An important use of the general-purpose events is to implement device wake events. The components of the ACPI event programming model interact in the following way:

- When a device asserts its wake signal, the general-purpose status event bit used to track that device is set.
- While the corresponding general-purpose enable bit is enabled, the SCI interrupt is asserted.
- If the system is sleeping, this will cause the hardware, if possible, to transition the system into the S0 state.
- Once the system is running, OSPM will dispatch the corresponding GPE handler.
- The handler needs to determine which device object has signaled wake and performs a wake Notify command on the corresponding device object(s) that have asserted wake.
- In turn OSPM will notify OSPM native driver(s) for each device that will wake its device to service it.

Events that wake may not be intermixed with non-wake (runtime) events on the same GPE input. The only exception to this rule is made for the special devices below. Only the following devices are allowed to utilize a single GPE for both wake and runtime events:

1. Button Devices: PNP0C0C - Power Button Device | PNP0C0D - Lid Device | PNP0C0E - Sleep Button Device
2. PCI Bus Wakeup Event Reporting (PME): PNP0A03 - PCI Host Bridge

All wake events that are not exclusively tied to a GPE input (for example, one input is shared for multiple wake events) must have individual enable and status bits in order to properly handle the semantics used by the system.

5.6.4.2.1 Managing a Wake Event Using Device `_PRW` Objects

A device's `_PRW` object provides the zero-based bit index into the general-purpose status register block to indicate which general-purpose status bit from either `GPE0_BLK` or `GPE1_BLK` is used as the specific device's wake mask. Although the hardware must maintain individual device wake enable bits, the system can have multiple devices using the same general-purpose event bit by using OEM-specific hardware to provide second-level status and enable bits. In this case, the OEM AML code is responsible for the second-level enable and status bits.

OSPM enables or disables the device wake function by enabling or disabling its corresponding GPE and by executing its `_PSW` control method (which is used to take care of the second-level enables). When the GPE is asserted, OSPM still executes the corresponding GPE control method that determines which device wakes are asserted and notifies the corresponding device objects. The native OS driver is then notified that its device has asserted wake, for which the driver powers on its device to service it.

If the system is in a sleeping state when the enabled GPE bit is asserted the hardware will transition the system into the S0 state, if possible.

5.6.4.2.2 Determining the System Wake Source Using `_Wxx` Control Methods

After a transition to the S0 state, OSPM may evaluate the `_SWS` object in the `_GPE` scope to determine the index of the GPE that was the source of the transition event. When a single GPE is shared among multiple devices, the platform provides a `_Wxx` control method, where `xx` is GPE index as described in *Determining the System Wake Source Using `_Wxx` Control Methods*, that allows the source device of the transition to be determined. If implemented, the `_Wxx` control method must exist in the `_GPE` scope or in the scope of a GPE block device.

If `_Wxx` is implemented, either hardware or firmware must detect and save the source device as described in *sws-system-wake-source*. During invocation, the `_Wxx` control method determines the source device and issues a **Notify**(<device>,0x2) on the device that caused the system to transition to the S0 state. If the device uses a bus-specific method of arming for wakeup, then the **Notify** must be issued on the parent of the device that has a `_PRW` method. The `_Wxx` method must issue a **Notify**(<device>,0x2) only to devices that contain a `_PRW` method within their device scope. OSPM's evaluation of the `_SWS` and `_Wxx` objects is indeterminate. As such, the platform must not rely on `_SWS` or `_Wxx` evaluation to clear any hardware state, including `GPEX_STS` bits, or to perform any wakeup-related actions.

If the GPE index returned by the `_SWS` object is only referenced by a single `_PRW` object in the system, it is implied that the device containing that `_PRW` is the wake source. In this case, it is not necessary for the platform to provide a `_Wxx` method.

5.6.5 GPIO-sigaled ACPI Events

On Hardware-reduced ACPI platforms, ACPI events can be signaled when a GPIO Interrupt is received by OSPM, and that GPIO Interrupt Connection is listed in a GPIO controller device's `_AEI` object. OSPM claims all such GPIO interrupts, and maps them to the appropriate event method required by the ACPI event model.

5.6.5.1 Declaring GPIO Controller Devices

A GPIO controller is modeled as a device in the namespace, with `_HID` or `_ADR` and `_CRS` objects, at a minimum. Optionally, the GPIO controller device scope may include GeneralPurposeIO OpRegion declarations (Section 5.5.2.4.5) and GPIO interrupt-to-ACPI Event mappings (Section 5.6.5.2). Note that for *GPIO-sigaled ACPI Events*, the corresponding event method (e.g. `_Exx`, `_Lxx`, or `_EVT`) must also appear in the target GPIO controller's scope. For GPIO event numbers larger than 255 (0xFF), the `_EVT` method is used.

Each pin on a GPIO Controller has a configuration (e.g. level-sensitive interrupt, de-bounced input, high-drive output, etc.), which is described to OSPM in the GPIO Interrupt or GPIO IO Connection resources claimed by peripheral devices or used in operation region accesses.

5.6.5.2 `_AEI` Object for GPIO-sigaled Events

The `_AEI` object designates those GPIO interrupts that shall be handled by OSPM as ACPI events (see Section 5.6.5). This object appears within the scope of the GPIO controller device whose pins are to be used as GPIO-sigaled events.

Arguments:

None

Return Value:

A resource template Buffer containing only GPIO Interrupt Connection descriptors.

Example:

```
Device (\_SB.GPI2)
{
  Name(_HID, "XYZ0003")
  Name(_UID, 2) //Third instance of this controller on the_
platform
  Name(_CRS, ResourceTemplate ()
  {
    //Register Interface
    MEMORY32FIXED(ReadWrite, 0x30000000, 0x200, ) //Interrupt line (GSIV 21)
    Interrupt(ResourceConsumer, Level, ActiveHigh, Exclusive) {21}
  })
  Name(_AEI, ResourceTemplate ()
  {
    //Thermal Zone Event
    GpioInt(Edge, ActiveHigh, Exclusive, PullDown, , " \\\_SB.GPI2") {14}
    //Power Button
    GpioInt(Edge, ActiveLow, ExclusiveAndWake, PullUp, , " \\\_SB.GPI2") {36}
  })
}
```

5.6.5.3 The Event (_EVT) Method for Handling GPIO-sigaled Events

GPIO Interrupt Connection Descriptors assign GPIO pins a controller-relative, 0-based pin number. GPIO Pin numbers can be as large as 65, 535. GPIO Interrupt Connections that are assigned by the platform to signal ACPI events are listed in the _AEI object under the GPIO controller. Since the GPIO interrupt connection descriptor also provides the mode of the interrupt associated with an event, it gives OSPM all the information it needs to invoke a handler method for the event. No naming convention is required to encode the mode and pin number of the event. Instead, a handler for a GPIO-sigaled event simply needs to have a well-known name and take the pin number of the event as a parameter. A single instance of the method handles all ACPI events for a given GPIO controller device.

For GPIO-sigaled events, the Event (_EVT) method is used. _EVT is defined as follows:

Arguments (1):

Arg0 - EventNumber. An Integer indicating the event number (Controller-relative zero-based GPIO pin number) of the current event. Must be in the range 0x0000 - 0xffff.

Return Value:

None

Description:

The _EVT method handles a GPIO-sigaled event. It must appear within the scope of the GPIO controller device whose pins are used to signal the event.

OSPM handles GPIO-sigaled events as follows:

- The GPIO interrupt is handled by OSPM because it is listed in the _AEI object under a GPIO controller.
- When the event fires, OSPM handles the interrupt according to its mode and invokes the _EVT method, passing it the pin number of the event.
- From this point on, handling is exactly like that for GPEs. The _EVT method does a Notify() on the appropriate device, and OS-specific mechanisms are used to notify the driver of the event.
- For event numbers less than 255, _Exx and _Lxx methods may be used instead. In this case, they take precedence and _EVT will not be invoked.

Note: For event numbers less than 255, _Exx and _Lxx methods may be used instead. In this case, they take precedence and _EVT will not be invoked.

Example:

```
Scope (\_SB.GPI2)
{
  Method (_EVT,1) { // Handle all ACPI Events signaled by GPIO Controller GPI2
    Switch (Arg0)
    {
      Case (300) {
        ...
        Notify (\_SB.DEVX, 0x80)
      }
      Case (1801) {
        ...
        Notify (\_SB.DEVY, 0x80)
      }
      Case (14...) {
```

(continues on next page)

(continued from previous page)

```

    ...
    Notify (\_SB.DEVZ, 0x80)
  }
  ...
}
} //End of Method
} //End of Scope

```

5.6.6 Device Object Notifications

During normal operation, the platform needs to notify OSPM of various device-related events. These notifications are accomplished using the Notify operator, which indicates a target device, thermal zone, or processor object and a notification value that signifies the purpose of the notification. Notification values from 0 through 0x7F are common across all device object types. Notification values of 0xC0 and above are reserved for definition by hardware vendors for hardware specific notifications. Notification values from 0x80 to 0xBF are device-specific and defined by each such device. For more information on the Notify operator, see [Section 19.6.94](#).

Table 5.187: Device Object Notification Values

Value	Description
0	Bus Check. This notification is performed on a device object to indicate to OSPM that it needs to perform a Plug and Play re-enumeration operation on the device tree starting from the point where it has been notified. OSPM will typically perform a full enumeration automatically at boot time, but after system initialization it is the responsibility of the ACPI AML code to notify OSPM whenever a re-enumeration operation is required. The more accurately and closer to the actual change in the device tree the notification can be done, the more efficient the operating system's response will be; however, it can also be an issue when a device change cannot be confirmed. For example, if the hardware cannot recognize a device change for a particular location during a system sleeping state, it issues a Bus Check notification on wake to inform OSPM that it needs to check the configuration for a device change.
1	Device Check. Used to notify OSPM that the device either appeared or disappeared. If the device has appeared, OSPM will re-enumerate from the parent. If the device has disappeared, OSPM will invalidate the state of the device. OSPM may optimize out re-enumeration. If <code>_DCK</code> is present, then <code>Notify(object,1)</code> is assumed to indicate an undock request. If the device is a bridge, OSPM may re-enumerate the bridge and the child bus.
2	Device Wake. Used to notify OSPM that the device has signaled its wake event, and that OSPM needs to notify OSPM native device driver for the device. This is only used for devices that support <code>_PRW</code> .
3	Eject Request. Used to notify OSPM that the device should be ejected, and that OSPM needs to perform the Plug and Play ejection operation. OSPM will run the <code>_EJx</code> method.
4	Device Check Light. Used to notify OSPM that the device either appeared or disappeared. If the device has appeared, OSPM will re-enumerate from the device itself, not the parent. If the device has disappeared, OSPM will invalidate the state of the device.
5	Frequency Mismatch. Used to notify OSPM that a device inserted into a slot cannot be attached to the bus because the device cannot be operated at the current frequency of the bus. For example, this would be used if a user tried to hot-plug a 33 MHz PCI device into a slot that was on a bus running at greater than 33 MHz.
6	Bus Mode Mismatch. Used to notify OSPM that a device has been inserted into a slot or bay that cannot support the device in its current mode of operation. For example, this would be used if a user tried to hot-plug a PCI device into a slot that was on a bus running in PCI-X mode.

continues on next page

Table 5.187 – continued from previous page

Value	Description
7	Power Fault. Used to notify OSPM that a device cannot be moved out of the D3 state because of a power fault.
8	Capabilities Check. This notification is performed on a device object to indicate to OSPM that it needs to re-evaluate the _OSC control method associated with the device.
9	Device _PLD Check. Used to notify OSPM to reevaluate the _PLD object, as the Device’s connection point has changed.
0xA	Reserved.
0xB	System Locality Information Update. Dynamic reconfiguration of the system may cause existing relative distance information to change. The platform sends the System Locality Information Update notification to a point on a device tree to indicate to OSPM that it needs to invoke the _SLI objects associated with the System Localities on the device tree starting from the point notified.
0x0C	Reserved.
0x0D	System Resource Affinity Update. Dynamic migration of devices may cause existing system resource affinity to change. The platform software issues the System Resource Affinity Update notification to a point on a device tree to indicate to OSPM that it needs to invoke the _PXM object of the notified device to update the resource affinity.
0x0E	Heterogeneous Memory Attributes Update. Dynamic reconfiguration of the system may cause existing latency, bandwidth or memory side caching attribute to change. The platform software issues the Heterogeneous Memory Attributes Update notification to a point on a device tree to indicate to OSPM that it needs to invoke the _HMA objects associated with the Heterogeneous Memory Attributes on the device tree starting from the point notified.
0x0F	Error Disconnect Recover: Used to notify OSPM of asynchronous removal of devices for error containment purposes. The notification is issued on a bus device that is still present, but one or more of its child device have been disconnected from the system due to an error condition. OSPM should invalidate the software state associated with the disconnected child devices without attempting to access these child devices. Subsequently, OSPM can optionally attempt to recover the disconnected child devices and ,if possible, bring them back to functional state via bus specific methods. OSPM communicates the status of these recovery operations to the Firmware via the _OST method. Section 6.3.5.2 describes the associated _OST status codes. OSPM support for Error Disconnect Recover notification for a given type of bus is enumerated via a bus specific mechanism.
0x10-0xFF	Reserved.

Below are the notification values defined for specific ACPI devices. For more information concerning the object-specific notification, see the section for the corresponding device/object.

Table 5.188: System Bus Notification Values

Hex value	Description
0x80	Reserved.
0x81	Graceful Shutdown Request. Used to notify OSPM that a graceful shutdown of the operating system has been requested. Once the operating system has finished its graceful shutdown procedure it should initiate a transition to the G2 “soft off” state. The Notify operator must target the System Bus: (_SB). See Section 6.3.5 for a description of shutdown processing.

Table 5.189: Control Method Battery Device Notification Values

Hex value	Description
0x80	Battery Status Changed. Used to notify OSPM that the Control Method Battery device status has changed.
0x81	Battery Information Changed. Used to notify OSPM that the Control Method Battery device information has changed. This only occurs when a battery is replaced.
0x82	Battery Maintenance Data Status Flags Check. Used to notify OSPM that the Control Method Battery device battery maintenance data status flags should be checked.
0x83-0xBF	<i>Reserved</i>

Table 5.190: Power Source Object Notification Values

Hex value	Description
0x80	Power Source Status Changed. Used to notify OSPM that the power source status has changed.
0x81	Power Source Information Changed. Used to notify OSPM that the power source information has changed.
0x82-0xBF	<i>Reserved</i>

Table 5.191: Thermal Zone Object Notification Values

Hex value	Description
0x80	Thermal Zone Status Changed. Used to notify OSPM that the thermal zone temperature has changed.
0x81	Thermal Zone Trip points Changed. Used to notify OSPM that the thermal zone trip points have changed.
0x82	Device Lists Changed. Used to notify OSPM that the thermal zone device lists (_ALx, _PSL, _TZD) have changed.
0x83	Thermal / Active Cooling Relationship Table Changed. Used to notify OSPM that values in the either the thermal relationship table or the active cooling relationship table have changed.
0x84-0xBF	<i>Reserved</i>

Table 5.192: Control Method Power Button Notification Values

Hex value	Description
0x80	S0 Power Button Pressed. Used to notify OSPM that the power button has been pressed while the system is in the S0 state. Notice that when the button is pressed while the system is in the S1-S4 state, a Device Wake notification must be issued instead.
0x81-0xBF	<i>Reserved</i>

Table 5.193: Control Method Sleep Button Notification Values

Hex value	Description
0x80	S0 Sleep Button Pressed. Used to notify OSPM that the sleep button has been pressed while the system is in the S0 state. Notice that when the button is pressed while the system is in the S1-S4 state, a Device Wake notification must be issued instead.
0x81-0xBF	<i>Reserved</i>

Table 5.194: Control Method Lid Notification Values

Hex value	Description
0x80	Lid Status Changed. Used to notify OSPM that the control method lid device status has changed.

continues on next page

Table 5.194 – continued from previous page

Hex value	Description
0x81-0xBF	<i>Reserved</i>

Table 5.195: NVDIMM Root Device Notification Values

Hex value	Description
0x80	NFIT Update Notification. Used to notify OSPM that it needs to re-evaluate the <code>_FIT</code> method under the NVDIMM root device (see Section 9.19.2).
0x81	Unconsumed Uncorrectable Memory Error Detected. Used to pro-actively notify OSPM of uncorrectable memory errors detected (for example a memory scrubbing engine that continuously scans the NVDIMMs memory). This is an optional notification. Only locations that were mapped in to SPA by the platform will generate a notification.
0x82	ARS Stopped Notification. This is an optional notification, used to notify OSPM when the platform completes ARS or when ARS has stopped prematurely for any ARS that was either started by the platform or by OSPM via Start ARS (see Section 9.19.7.5). The OSPM can evaluate Query ARS Status on receiving this event notification.
0x83-0xBF	<i>Reserved</i>

Table 5.196: NVDIMM Device Notification Values

Hex value	Description
0x80	<i>Reserved</i>
0x81	NFIT Health Event Notification. Used to notify OSPM of health event(s) for the NVDIMM device (see Section 9.19.3). On receiving the NFIT Health Event Notification, the OSPM is required to determine new health event by re-enumerating the health of the corresponding NVDIMM device. This could be accomplished by evaluating the <code>_NCH</code> method (see Section 9.19.8.1) or <code>_DSM</code> method under the NVDIMM device. This is also used to notify OSPM of a change in the “Overall Health Status Attributes” field reported by the <code>_NCH</code> method.
0x82-0xBF	<i>Reserved</i>

Table 5.197: Processor Device Notification Values

Hex value	Description
0x80	Performance Present Capabilities Changed. Used to notify OSPM that the number of supported processor performance states has changed. This notification causes OSPM to re-evaluate the <code>_PPC</code> object. See Section 8.4.5.3 for more information.
0x81	C States Changed. Used to notify OSPM that the number or type of supported processor C States has changed. This notification causes OSPM to re-evaluate the <code>_CST</code> object. See Section 8.4.1.1 for more information.
0x82	Throttling Present Capabilities Changed. Used to notify OSPM that the number of supported processor throttling states has changed. This notification causes OSPM to re-evaluate the <code>_TPC</code> object. See Section 8.4.4.3 for more information.
0x83	Guaranteed Changed. Used to notify OSPM that the value of the CPPC Guaranteed Register has changed.
0x84	Minimum Excursion. Used to notify OSPM that an excursion to CPPC Minimum has occurred.
0x85	Highest Performance Changed. Used to notify OSPM that the value of the CPPC Highest Performance Register has changed.
0x86-0xBF	<i>Reserved</i>

Table 5.198: User Presence Device Notification Values

Hex value	Description
0x80	User Presence Changed. Used to notify OSPM that a meaningful change in user presence has occurred, causing OSPM to re-evaluate the _UPD object.
0x81-0xBF	<i>Reserved</i>

Table 5.199: Ambient Light Sensor Device Notification Values

Hex value	Description
0x80	ALS Illuminance Changed. Used to notify OSPM that a meaningful change in ambient light illuminance has occurred, causing OSPM to re-evaluate the _ALI object.
0x81	ALS Color Temperature Changed. Used to notify OSPM that a meaningful change in ambient light color temperature or chromaticity has occurred, causing OSPM to re-evaluate the _ALT and/or _ALC objects.
0x82	ALS Response Changed. Used to notify OSPM that the set of points used to convey the ambient light response has changed, causing OSPM to re-evaluate the _ALR object.
0x83-0xBF	<i>Reserved</i>

Table 5.200: Power Meter Object Notification Values

Hex value	Description
0x80	Power Meter Capabilities Changed. Used to notify OSPM that the power meter information has changed.
0x81	Power Meter Trip Points Crossed. Used to notify OSPM that one of the power meter trip points has been crossed.
0x82	Power Meter Hardware Limit Changed. Used to notify OSPM that the hardware limit has been changed by the platform.
0x83	Power Meter Hardware Limit Enforced. Used to notify OSPM that the hardware limit has been enforced by the platform.
0x84	Power Meter Averaging Interval Changed. Used to notify OSPM that the power averaging interval has changed.
0x85-0xBF	<i>Reserved</i>

Table 5.201: Processor Aggregator Device Notification Values

Hex value	Description
0x80	Processor Utilisation Request. Used to notify OSPM that OSPM evaluates the _PUR object which indicates to OSPM the number of logical processors to be idled.
0x81-0xBF	<i>Reserved</i>

Table 5.202: Error Device Notification Values

Hex value	Description
0x80	Notification For Generic Error Sources. Used to notify OSPM to respond to this notification by checking the error status block of all generic error sources to identify the source reporting the error.
0x81-0xBF	<i>Reserved</i>

Table 5.203: Fan Device Notification Values

Hex value	Description
0x80	Low Fan Speed. Used to notify OSPM of a low (errant) fan speed. Causes OSPM to re-evaluate the <code>_FSL</code> object.
0x81-0xBF	<i>Reserved</i>

Table 5.204: Memory Device Notification Values

Hex value	Description
0x80	Memory Bandwidth Low Threshold crossed. Used to notify OSPM that bandwidth of memory described by the memory device has been reduced by the platform to less than the low memory bandwidth threshold.
0x81	Memory Bandwidth High Threshold crossed. Used to notify OSPM that bandwidth of memory described by the memory device has been increased by the platform to greater than or equal to the high memory bandwidth threshold.
0x82-0xBF	<i>Reserved</i>

5.6.7 Device Class-Specific Objects

Most device objects are controlled through generic objects and control methods and they have generic device IDs. These generic objects, control methods, and device IDs are specified in Section 6, through Section 11. Section 5.6.8, “Predefined ACPI Names for Objects, Methods, and Resources,” lists all the generic objects and control methods defined in this specification.

However, certain integrated devices require support for some device-specific ACPI controls. This section lists these devices, along with the device-specific ACPI controls that can be provided.

Some of these controls are for ACPI-aware devices and as such have Plug and Play IDs that represent these devices. The table below lists the Plug and Play IDs defined by the ACPI specification.

Note: Plug and Play IDs that are not defined by the ACPI specification are defined and described in the “Links to ACPI-Related Documents” (<http://uefi.org/acpi>) under the heading “Legacy PNP Guidelines”.

Table 5.205: ACPI Device IDs

Plug and Play ID	Description
PNP0C08	ACPI. Not declared in ACPI as a device. This ID is used by OSPM for the hardware resources consumed by the ACPI fixed register spaces, and the operation regions used by AML code. It represents the core ACPI hardware itself.
PNP0A05	Generic Container Device. A device whose settings are totally controlled by its ACPI resource information, and otherwise needs no device or bus-specific driver support. This was originally known as Generic ISA Bus Device. This ID should only be used for containers that do not produce resources for consumption by child devices. Any system resources claimed by a PNP0A05 device’s <code>_CRS</code> object must be consumed by the container itself.
PNP0A06	Generic Container Device. This device behaves exactly the same as the PNP0A05 device. This was originally known as Extended I/O Bus. This ID should only be used for containers that do not produce resources for consumption by child devices. Any system resources claimed by a PNP0A06 device’s <code>_CRS</code> object must be consumed by the container itself.
PNP0C09	Embedded Controller Device. A host embedded controller controlled through an ACPI-aware driver.

continues on next page

Table 5.205 – continued from previous page

Plug and Play ID	Description
PNP0C0A	Control Method Battery. A device that solely implements the ACPI Control Method Battery functions. A device that has some other primary function would use its normal device ID. This ID is used when the devices primary function is that of a battery.
PNP0C0B	Fan. A device that causes cooling when “on” (D0 device state).
PNP0C0C	Power Button Device. A device controlled through an ACPI-aware driver that provides power button functionality. This device is only needed if the power button is not supported using the fixed register space.
PNP0C0D	Lid Device. A device controlled through an ACPI-aware driver that provides lid status functionality. This device is only needed if the lid state is not supported using the fixed register space.
PNP0C0E	Sleep Button Device. A device controlled through an ACPI-aware driver that provides power button functionality. This device is optional.
PNP0C0F	PCI Interrupt Link Device. A device that allocates an interrupt connected to a PCI interrupt pin. See Section 6.2.13 for more details.
PNP0C80	Memory Device. This device is a memory subsystem.
ACPI0001	SMBus 1.0 Host Controller. An SMBus host controller (SMB-HC) compatible with the embedded controller-based SMB-HC interface (see Section 12.9), and implementing the SMBus 1.0 Specification.
ACPI0002	Smart Battery Subsystem. The Smart battery Subsystem specified in Section 10, “Power Source Devices.”
ACPI0003	Power Source Device. The Power Source device specified in Section 10, “Power Source Devices.” This can represent either an AC Adapter (on mobile platforms) or a fixed Power Supply.
ACPI0004	Module Device. This device is a container object that acts as a bus node in a namespace. A Module Device without any of the <code>_CRS</code> , <code>_PRS</code> and <code>_SRS</code> methods behaves the same way as the Generic Container Devices (PNP0A05 or PNP0A06). If the Module Device contains a <code>_CRS</code> method, only these resources described in the <code>_CRS</code> are available for consumption by its child devices. Also, the Module Device can support <code>_PRS</code> and <code>_SRS</code> methods if <code>_CRS</code> is supported.
ACPI0005	SMBus 2.0 Host Controller. An SMBus host controller (SMB-HC) compatible with the embedded controller-based SMB-HC interface (see Section 12.9), and implementing the SMBus 2.0 Specification.
ACPI0006	GPE Block Device. This device allows a system designer to describe GPE blocks beyond the two that are described in the FADT.
ACPI0007	Processor Device. This device provides an alternative to declaring processors using the processor ASL statement. See Section 8.4 for more details.
ACPI0008	Ambient Light Sensor Device. This device is an ambient light sensor. See Section 9.3 .
ACPI0009	I/OxAPIC Device. This device is an I/O unit that complies with both the APIC and SAPIC interrupt models.
ACPI000A	I/O APIC Device. This device is an I/O unit that complies with the APIC interrupt model.
ACPI000B	I/O SAPIC Device. This device is an I/O unit that complies with the SAPIC interrupt model.
ACPI000C	Processor Aggregator Device. This device provides a control point for all processors in the platform. See Section 8.5 .
ACPI000D	Power Meter Device. This device is a power meter. See Section 10.4 .
ACPI000E	Time and Alarm Device. This device is a control method-based real-time clock and wake alarm. See Section 9.17 .
ACPI000F	User Presence Detection Device. This device senses user presence (proximity). See Section 9.15

continues on next page

Table 5.205 – continued from previous page

Plug and Play ID	Description
ACPI0010	Processor container device. Used to declare hierarchical processor topologies (see Section 8.4.2, and Section 8.4.2.1).
ACPI0011	Generic Buttons Device. This device reports button events corresponding to Human Interface Device (HID) control descriptors (see Section 9.18).
ACPI0012	NVDIMM Root Device. This device contains the NVDIMM devices. See Section 9.19 and Table 5.126.
ACPI0013	Generic Event Device. This device maps Interrupt-signaled events. See Section 5.6.9.
ACPI0014	Wireless Power Calibration Device. This device uses user presence and notification.
ACPI0015	USB4 host interface device. See Links to ACPI-Related Documents under the heading “USB4 Host Interface Specification”
ACPI0016	Compute Express Link Host Bridge. This device is a Compute Express Link Host bridge.
ACPI0017	Compute Express Link Root Object. This device represents the root of a CXL capable device hierarchy. It shall be present whenever the platform allows OSPM to dynamically assign CXL endpoints to a platform address space.
ACPI0018	Audio Composition Device. This is an ACPI-enumerated device that describes audio component logical connection information within a system.

5.6.8 Predefined ACPI Names for Objects, Methods, and Resources

The following table summarizes the predefined names for the ACPI namespace objects, control methods, and resource descriptor fields defined in this specification. Provided for each name is a short description and a reference to the section number and page number of the actual definition of the name. ACPI names that are predefined by other specifications are also listed along with their corresponding specification reference.

Note: All names that begin with an underscore are reserved for ACPI use only.

Table 5.206: Predefined ACPI Names

Name	Description
_ACx	Active Cooling – returns the active cooling policy threshold values.
_ADR	Address: (1) returns the address of a device on its parent bus. (2) returns a unique ID for the display output device. (3) resource descriptor field.
_AEI	Designates those GPIO interrupts that shall be handled by OSPM as ACPI events.
_ALC	Ambient Light Chromaticity – returns the ambient light color chromaticity.
_ALI	Ambient Light Illuminance – returns the ambient light brightness.
_ALN	Alignment – base alignment, resource descriptor field.
_ALP	Ambient Light Polling – returns the ambient light sensor polling frequency.
_ALR	Ambient Light Response – returns the ambient light brightness to display brightness mappings.
_ALT	Ambient Light Temperature – returns the ambient light color temperature.
_ALx	Active List – returns a list of active cooling device objects.
_ART	Active cooling Relationship Table – returns thermal relationship information between platform devices and fan devices.
_ASI	Address Space Id – resource descriptor field.
_ASZ	Access Size – resource descriptor field.
_ATT	Type-Specific Attribute – resource descriptor field.
_BAS	Base Address – range base address, resource descriptor field.
_BBN	Bios Bus Number – returns the PCI bus number returned by the platform firmware.
_BCL	Brightness Control Levels – returns a list of supported brightness control levels.

continues on next page

Table 5.206 – continued from previous page

Name	Description
_BCM	Brightness Control Method – sets the brightness level of the display device.
_BCT	Battery Charge Time – returns time remaining to complete charging battery.
_BDN	Bios Dock Name – returns the Dock ID returned by the platform firmware.
_BIF	Battery Information – returns a Control Method Battery information block.
_BIX	Battery Information Extended – returns a Control Method Battery extended information block.
_BLT	Battery Level Threshold – set battery level threshold preferences.
_BM	Bus Master – resource descriptor field.
_BMA	Battery Measurement Averaging Interval – Sets battery measurement averaging interval.
_BMC	Battery Maintenance Control – Sets battery maintenance and control features.
_BMD	Battery Maintenance Data – returns battery maintenance, control, and state data.
_BMS	Battery Measurement Sampling Time – Sets the battery measurement sampling time.
_BPC	Battery Power Characteristics
_BPS	Battery Power State
_BPT	Battery Power Threshold
_BQC	Brightness Query Current – returns the current display brightness level.
_BST	Battery Status – returns a Control Method Battery status block.
_BTH	Battery Throttle Limit - specifies the thermal throttle limit of battery for the firmware when engaging charging.
_BTM	Battery Time – returns the battery runtime.
_BTP	Battery Trip Point – sets a Control Method Battery trip point.
_CBA	Configuration Base Address – returns the base address of the MMIO range corresponding to the Enhanced Configuration Access Mechanism for a PCI Express or Compute Express Link host bus. The full description for the _CBA object resides in the PCI Firmware Specification. A reference to that specification is found in the “Links to ACPI-Related Documents” (http://uefi.org/acpi) under the heading “PCI SIG”.
_CBR	CXL Host Bridge Register Info
_CCA	Cache Coherency Attribute – specifies whether a device and its descendants support hardware managed cache coherency.
_CDM	Clock Domain – returns a logical processor’s clock domain identifier.
_CID	Compatible ID – returns a device’s Plug and Play Compatible ID list.
_CLS	Class Code – supplies OSPM with the PCI-defined class, subclass and programming interface for a device. Optional.
_CPC	Continuous Performance Control – declares an interface that allows OSPM to transition the processor into a performance state based on a continuous range of allowable values.
_CRS	Current Resource Settings – returns the current resource settings for a device.
_CRT	Critical Temperature – returns the shutdown critical temperature.
_CSD	C State Dependencies – returns a list of C-state dependencies.
_CST	C States – returns a list of supported C-states.
_CWS	Clear Wake Status – Clears the wake status of a Time and Alarm Control Method Device.
_DBT	Debounce Timeout -Debounce timeout setting for a GPIO input connection, resource descriptor field
_DCK	Dock – sets docking isolation. Presence indicates device is a docking station.
_DCS	Display Current Status – returns status of the display output device.
_DDC	Display Data Current – returns the EDID for the display output device.
_DDN	Dos Device Name – returns a device logical name.
_DEC	Decode – device decoding type, resource descriptor field.
_DEP	Operation Region Dependencies – evaluates to a package and designates device objects that OSPM should assign a higher priority in start ordering due to future operation region accesses.
_DGS	Display Graphics State – returns the current state of the output device.
_DIS	Disable – disables a device.

continues on next page

Table 5.206 – continued from previous page

Name	Description
_DLM	Device Lock Mutex- Designates a mutex as a Device Lock.
_DMA	Direct Memory Access – returns a device’s current resources for DMA transactions.
_DOD	Display Output Devices – enumerate all devices attached to the display adapter.
_DOS	Disable Output Switching – sets the display output switching mode.
_DPL	Device Selection Polarity - The polarity of the Device Selection signal on a SPI SerialBus connection, resource descriptor field
_DRS	Drive Strength – Drive strength setting for a GPIO output connection, resource descriptor field
_DSD	Device Specific Data– returns device-specific information.
_DSM	Device Specific Method – executes device-specific functions.
_DSS	Device Set State – sets the display device state.
_DSW	Device Sleep Wake – sets the sleep and wake transition states for a device.
_DTI	Device Temperature Indication – conveys native device temperature to the platform.
_Exx	Edge GPE – method executed as a result of a general-purpose event.
_EC	Embedded Controller – returns EC offset and query information.
_EDL	Eject Device List – returns a list of devices that are dependent on a device (docking).
_EJD	Ejection Dependent Device – returns the name of dependent (parent) device (docking).
_EJx	Eject – begin or cancel a device ejection request (docking).
_END	Endian-ness – Endian orientation of a UART SerialBus connection, resource descriptor field
_EVT	Event Method - Event method for GPIO-signaled events numbered larger than 255.
_FDE	Floppy Disk Enumerate – returns floppy disk configuration information.
_FDI	Floppy Drive Information – returns a floppy drive information block.
_FDM	Floppy Drive Mode – sets a floppy drive speed.
_FIF	Fan Information – returns fan device information.
_FIT	Firmware Interface Table - returns a list of NFIT Structures.
_FIX	Fixed Register Resource Provider – returns a list of devices that implement FADT register blocks.
_FLC	Flow Control – Flow Control mechanism for a UART SerialBus connection, resource descriptor field
_FPS	Fan Performance States – returns a list of supported fan performance states.
_FSL	Fan Set Level – Control method that sets the fan device’s speed level (performance state).
_FST	Fan Status – returns current status information for a fan device.
_GAI	Get Averaging Interval – returns the power meter averaging interval.
_GCP	Get Capabilities – Returns the capabilities of a Time and Alarm Control Method Device
_GHL	Get Hardware Limit – returns the hardware limit enforced by the power meter.
_GL	Global Lock – OS-defined Global Lock mutex object.
_GLK	Global Lock – returns a device’s Global Lock requirement for device access.
_GPD	Get Post Data – returns the value of the VGA device that will be posted at boot.
_GPE	General Purpose Events: (1) predefined Scope (_GPE). (2) Returns the SCI interrupt associated with the Embedded Controller.
_GRA	Granularity – address space granularity, resource descriptor field.
_GRT	Get Real Time – Returns the current time from a Time and Alarm Control Method Device.
_GSB	Global System Interrupt Base – returns the GSB for a I/O APIC device.
_GTF	Get Task File – returns a list of ATA commands to restore a drive to default state.
_GTM	Get Timing Mode – returns a list of IDE controller timing information.
_GWS	Get Wake Status – Gets the wake status of a Time and Alarm Control Method Device.
_HE	High-Edge – interrupt triggering, resource descriptor field.
_HID	Hardware ID – returns a device’s Plug and Play Hardware ID.
_HMA	Heterogeneous Memory Attributes - returns a list of HMAT structures.
_HOT	Hot Temperature – returns the critical temperature for sleep (entry to S4).
_HPP	Hot Plug Parameters – returns a list of hot-plug information for a PCI device.

continues on next page

Table 5.206 – continued from previous page

Name	Description
_HPX	Hot Plug Parameter Extensions – returns a list of hot-plug information for a PCI device. Supercedes _HPP.
_HRV	Hardware Revision– supplies OSPM with the device’s hardware revision. Optional.
_IFT	IPMI Interface Type. See the Intelligent Platform Management Interface Specification at “Links to ACPI-Related Documents” (http://uefi.org/acpi) under the heading “Server Platform Management Interface Table”.
_INI	Initialize – performs device specific initialization.
_INT	Interrupts – interrupt mask bits, resource descriptor field.
_IOR	IO Restriction – IO restriction setting for a GPIO IO connection, resource descriptor field
_IRC	Inrush Current – presence indicates that a device has a significant inrush current draw.
_Lxx	Level GPE – Control method executed as a result of a general-purpose event.
_LCK	Lock – locks or unlocks a device (docking).
_LEN	Length – range length, resource descriptor field.
_LID	Lid – returns the open/closed status of the lid on a mobile system.
_LIN	Lines in Use - Handshake lines in use in a UART SerialBus connection, resource descriptor field
_LL	Low Level – interrupt polarity, resource descriptor field.
_LPI	Low Power Idle States – returns the list of low power idle states supported by a processor or processor container.
_LSI	Label Storage Information – Returns information about the Label Storage Area associated with the NVDIMM object, including its size.
_LSR	Label Storage Read – Returns label data from the Label Storage Area of the NVDIMM object.
_LSW	Label Storage Write – Writes label data in to the Label Storage Area of the NVDIMM object.
_MAF	Maximum Address Fixed – resource descriptor field.
_MAT	Multiple Apic Table Entry – returns a list of Interrupt Controller Structures.
_MAX	Maximum Base Address – resource descriptor field.
_MBM	Memory Bandwidth Monitoring Data – returns bandwidth monitoring data for a memory device.
_MEM	Memory Attributes – resource descriptor field.
_MIF	Minimum Address Fixed – resource descriptor field.
_MIN	Minimum Base Address – resource descriptor field.
_MLS	Multiple Language String – returns a device description in multiple languages.
_MOD	Mode –Resource descriptor field
_MSG	Message – sets the system message waiting status indicator.
_MSM	Memory Set Monitoring – sets bandwidth monitoring parameters for a memory device.
_MTL	Minimum Throttle Limit – returns the minimum throttle limit of a specific thermal.
_MTP	Memory Type – resource descriptor field.
_NTT	Notification Temperature Threshold – returns a threshold for device temperature change that requires platform notification.
_OFF	Off – sets a power resource to the off state.
_ON	On – sets a power resource to the on state.
_OS	Operating System – returns a string that identifies the operating system.
_OSC	Operating System Capabilities – inform AML of host features and capabilities.
_OSI	Operating System Interfaces – returns supported interfaces, behaviors, and features.
_OST	Ospm Status Indication – inform AML of event processing status.
_PAI	Power Averaging Interval – sets the averaging interval for a power meter.
_PAR	Parity – Parity for a UART SerialBus connection, resource descriptor field
_PCL	Power Consumer List – returns a list of devices powered by a power source.
_PCT	Performance Control – returns processor performance control and status registers.
_PDC	Processor Driver Capabilities – inform AML of processor driver capabilities.
_PDL	P-state Depth Limit – returns the lowest available performance P-state.

continues on next page

Table 5.206 – continued from previous page

Name	Description
_PHA	Clock Phase – Clock phase for a SPISerialBus connection, resource descriptor field
_PIC	PIC – inform AML of the interrupt model in use.
_PIF	Power Source Information – returns a Power Source information block.
_PIN	Pin List – List of GPIO pins described, resource descriptor field.
_PLD	Physical Location of Device – returns a device’s physical location information.
_PMC	Power Meter Capabilities – returns a list of Power Meter capabilities info.
_PMD	Power Metered Devices – returns a list of devices that are measured by the power meter device.
_PMM	Power Meter Measurement – returns the current value of the Power Meter.
_POL	Polarity – Resource descriptor field
_PPC	Performance Present Capabilites – returns a list of the performance states currently supported by the platform.
_PPE	Polling for Platform Error – returns the polling interval to retrieve Corrected Platform Error information.
_PPI	Pin Configuration – Pin configuration for a GPIO connection, resource descriptor field
_PR	Processor – predefined scope for processor objects.
_PR0	Power Resources for D0 – returns a list of dependent power resources to enter state D0 (fully on).
_PR1	Power Resources for D1 – returns a list of dependent power resources to enter state D1.
_PR2	Power Resources for D2 – returns a list of dependent power resources to enter state D2.
_PR3	Power Resources for D3hot – returns a list of dependent power resources to enter state D3hot.
_PRE	Power Resources for Enumeration - Returns a list of dependent power resources to enumerate devices on a bus.
_PRL	Power Source Redundancy List – returns a list of power source devices in the same redundancy grouping.
_PRR	Power Resource for Reset – executes a reset on the associated device or devices.
_PRS	Possible Resource Settings – returns a list of a device’s possible resource settings.
_PRT	Pci Routing Table – returns a list of PCI interrupt mappings.
_PRW	Power Resources for Wake – returns a list of dependent power resources for waking.
_PS0	Power State 0 – sets a device’s power state to D0 (device fully on).
_PS1	Power State 1 – sets a device’s power state to D1.
_PS2	Power State 2 – sets a device’s power state to D2.
_PS3	Power State 3 – sets a device’s power state to D3 (device off).
_PSC	Power State Current – returns a device’s current power state.
_PSD	Power State Dependencies – returns processor P-State dependencies.
_PSE	Power State for Enumeration
_PSL	Passive List – returns a list of passive cooling device objects.
_PSR	Power Source – returns the power source device currently in use.
_PSS	Performance Supported States – returns a list of supported processor performance states.
_PSV	Passive – returns the passive trip point temperature.
_PSW	Power State Wake – sets a device’s wake function.
_PTC	Processor Throttling Control – returns throttling control and status registers.
_PTP	Power Trip Points – sets trip points for the Power Meter device.
_PTS	Prepare To Sleep – inform the platform of an impending sleep transition.
_PUR	Processor Utilization Request – returns the number of processors that the platform would like to idle.
_PXM	Proximity – returns a device’s proximity domain identifier.
_Qxx	Query – Embedded Controller query and SMBus Alarm control method.
_RBO	Register Bit Offset – resource descriptor field.
_RBW	Register Bit Width – resource descriptor field.

continues on next page

Table 5.206 – continued from previous page

Name	Description
_RDI	Resource Dependencies for Idle - returns the list of power resource dependencies for system level low power idle states.
_REG	Region – inform AML code of an operation region availability change.
_REV	Revision – returns the revision of the ACPI specification that is implemented.
_RMV	Remove – returns a device’s removal ability status (docking).
_RNG	Range – memory range type, resource descriptor field.
_ROM	Read-Only Memory – returns a copy of the ROM data for a display device.
_RST	Device Reset – executes a reset on the associated device or devices.
_RT	Resource Type – resource descriptor field.
_RTV	Relative Temperature Values – returns temperature value information.
_RW	Read-Write Status – resource descriptor field.
_RXL	Receive Buffer Size - Size of the receive buffer in a UART Serialbus connection, resource descriptor field.
_S0	S0 System State – returns values to enter the system into the S0 state.
_S1	S1 System State – returns values to enter the system into the S1 state.
_S2	S2 System State – returns values to enter the system into the S2 state.
_S3	S3 System State – returns values to enter the system into the S3 state.
_S4	S4 System State – returns values to enter the system into the S4 state.
_S5	S5 System State – returns values to enter the system into the S5 state.
_S1D	S1 Device State – returns the highest D-state supported by a device when in the S1 state.
_S2D	S2 Device State – returns the highest D-state supported by a device when in the S2 state.
_S3D	S3 Device State – returns the highest D-state supported by a device when in the S3 state.
_S4D	S4 Device State – returns the highest D-state supported by a device when in the S4 state.
_S0W	S0 Device Wake State – returns the lowest D-state that the device can wake itself from S0.
_S1W	S1 Device Wake State – returns the lowest D-state for this device that can wake the system from S1.
_S2W	S2 Device Wake State – returns the lowest D-state for this device that can wake the system from S2.
_S3W	S3 Device Wake State – returns the lowest D-state for this device that can wake the system from S3.
_S4W	S4 Device Wake State – returns the lowest D-state for this device that can wake the system from S4.
_SB	System Bus – scope for device and bus objects.
_SBS	Smart Battery Subsystem – returns the subsystem configuration.
_SCP	Set Cooling Policy – sets the cooling policy (active or passive).
_SDD	Set Device Data – sets data for a SATA device.
_SEG	Segment – returns a device’s PCI Segment Group number.
_SHL	Set Hardware Limit – sets the hardware limit enforced by the Power Meter.
_SHR	Shareable - interrupt share status, resource descriptor field.
_SI	System Indicators – predefined scope.
_SIZ	Size – DMA transfer size, resource descriptor field.
_SLI	System Locality Information – returns a list of NUMA system localities.
_SLV	Slave Mode – Slave mode setting for a SerialBus connection, resource descriptor field.
_SPD	Set Post Device – sets which video device will be posted at boot.
_SPE	Connection Speed – Connection speed for a SerialBus connection, resource descriptor field
_SRS	Set Resource Settings – sets a device’s resource allocation.
_SRT	Set Real Time – Sets the current time to a Time and Alarm Control Method Device.
_SRV	IPMI Spec Revision. See the Intelligent Platform Management Interface Specification at “Links to ACPI-Related Documents” (http://uefi.org/acpi) under the heading “Server Platform Management Interface Table”.

continues on next page

Table 5.206 – continued from previous page

Name	Description
_SST	System Status – sets the system status indicator.
_STA	Status : (1) returns the current status of a device. (2) Returns the current on or off state of a Power Resource.
_STB	Stop Bits - Number of stop bits used in a UART SerialBus connection, resource descriptor field
_STM	Set Timing Mode – sets an IDE controller transfer timings.
_STP	Set Expired Timer Wake Policy – sets expired timer policies of the wake alarm device.
_STR	String – returns a device’s description string.
_STV	Set Timer Value – set timer values of the wake alarm device.
_SUB	Supplies OSPM with the device’s Subsystem ID. Optional.
_SUN	Slot User Number – returns the slot unique ID number.
_SWS	System Wake Source – returns the source event that caused the system to wake.
_T_x	Temporary – reserved for use by ASL compilers.
_TC1	Thermal Constant 1 – returns TC1 for the passive cooling formula.
_TC2	Thermal Constant 2 – returns TC2 for the passive cooling formula.
_TDL	T-State Depth Limit – returns the _TSS entry number of the lowest power throttling state.
_TFP	Thermal Fast Sampling Period - returns the thermal sampling period for passive cooling.
_TIP	Expired Timer Wake Policy – returns timer policies of the wake alarm device.
_TIV	Timer Values – returns remaining time of the wake alarm device.
_TMP	Temperature – returns a thermal zone’s current temperature.
_TPC	Throttling Present Capabilities – returns the current number of supported throttling states.
_TPT	Trip Point Temperature – inform AML that a devices’ embedded temperature sensor has crossed a temperature trip point.
_TRA	Translation – address translation offset, resource descriptor field.
_TRS	Translation Sparse – sparse/dense flag, resource descriptor field.
_TRT	Thermal Relationship Table – returns thermal relationships between platform devices.
_TSD	Throttling State Dependencies – returns a list of T-state dependencies.
_TSF	Type-Specific Flags – resource descriptor field.
_TSN	Thermal Sensor Device - returns a reference to the thermal sensor reporting a zone temperature
_TSP	Thermal Sampling Period – returns the thermal sampling period for passive cooling.
_TSS	Throttling Supported States – returns supported throttling state information.
_TST	Temperature Sensor Threshold – returns the minimum separation for a device’s temperature trip points.
_TTP	Translation Type – translation/static flag, resource descriptor field.
_TTS	Transition To State – inform AML of an S-state transition.
_TXL	Transmit Buffer Size – Size of the transmit buffer in a UART Serialbus connection, resource descriptor field
_TYP	Type – DMA channel type (speed), resource descriptor field.
_TZ	Thermal Zone – predefined scope: ACPI 1.0.
_TZD	Thermal Zone Devices – returns a list of device names associated with a Thermal Zone.
_TZM	Thermal Zone Member – returns a reference to the thermal zone of which a device is a member.
_TZP	Thermal Zone Polling – returns a Thermal zone’s polling frequency.
_UID	Unique ID – return a device’s unique persistent ID.
_UPC	USB Port Capabilities – returns a list of USB port capabilities.
_UPD	User Presence Detect – returns user detection information.
_UPP	User Presence Polling – returns the recommended user presence polling interval.
_VEN	Vendor-defined Data – Vendor-defined data for a GPIO or SerialBus connection, resource descriptor field
_VPO	Video Post Options – returns the implemented video post options.
_WAK	Wake – inform AML that the system has just awakened.

continues on next page

Table 5.206 – continued from previous page

Name	Description
_WPC	Wireless Power Calibration - returns the notifier to wireless power controller.
_WPP	Wireless Power Polling - returns the recommended polling frequency
_Wxx	Wake Event – method executed as a result of a wake event.

5.6.9 Interrupt-signaled ACPI events

ACPI 6.1 introduces support for generating ACPI events when an interrupt is received by the OSPM, and that interrupt is listed in the Generic Event Device (GED) _CRS object. OSPM claims all such interrupts, and maps them to the appropriate event method required by the ACPI event model.

5.6.9.1 Declaring Generic Event Device

The Generic Event Device (GED) is modelled as a device in the namespace with a _HID defined to be ACPI0013. The GED must also provide one _CRS and _EVT object for claiming interrupts and mapping them to ACPI events, as described in the following sections. The platform declare its support for the GED, and query whether an OS supports it, via the _OSC method, see [Section 6.2.11.2](#).

5.6.9.2 _CRS Object for Interrupt-signaled Events

The _CRS object designates those interrupts that shall be handled by OSPM as ACPI events. This object appears within the scope of the GED whose interrupts sources are to be used as Interrupt-signaled events.

Arguments:

None

Return Value:

A resource template **Buffer** containing only Interrupt Resource descriptors.

- For event numbers less than 255, _Exx and _Lxx methods may be used instead. In this case, they take precedence and _EVT will not be invoked.

Example:

```
Device (\_SB.GED1)
{
  Name (_HID, "ACPI0013")
  Name (_CRS, ResourceTemplate ()
  {
    Interrupt (ResourceConsumer, Level, ActiveHigh, Exclusive) {41}
    Interrupt (ResourceConsumer, Level, ActiveHigh, Shared) {42}
    Interrupt (ResourceConsumer, Level, ActiveHigh, ExclusiveAndWake) {43}
  })
  ...
} //End of Scope
```

5.6.9.3 The Event (_EVT) Method for Handling Interrupt-signaled Events

Interrupts that are assigned by the platform to signal ACPI events are listed in the _CRS object under the GED device. Since the interrupt descriptor also provides the mode of the interrupt associated with an event, it gives OSPM all the information it needs to invoke a handler method for the event. A single instance of the method handles all ACPI events for a given GED.

- Please refer to [Section 5.6.4](#) for the OSPM requirements of handling an event (steps 1-5).

For Interrupt-signaled events, the Event (_EVT) method is used.

_EVT is defined as follows:

Arguments: (1)

Arg0 - EventNumber. An Integer indicating the event number (GSIV number) of the current event. Must be in the range 0x00000000 - 0xffffffff.

Return Value:

None

Description

The _EVT method handles an Interrupt-signaled event. It must appear within the scope of the GED whose interrupts are used to signal the event.

OSPM handles Interrupt-signaled events as follows:

- The interrupt is handled by OSPM because it is listed in the _CRS object under a GED.
- When the event fires, OSPM handles the interrupt according to its mode and invokes the _EVT method, passing it the interrupt number of the event. In the case of level interrupts, the ASL within the _EVT method must be responsible for clearing the interrupt at the device.
- From this point on, handling is exactly like that for GPEs. The _EVT method may optionally call Notify() on the appropriate device, and OS-specific mechanisms are used to notify the driver of the event.

Example:

```
Device (\_SB.GED1)
{
  Name(_HID, "ACPI0013")
  Name(_CRS, ResourceTemplate ()
  {
    Interrupt(ResourceConsumer, Level, ActiveHigh, Exclusive) {41}
    Interrupt(ResourceConsumer, Edge, ActiveHigh, Shared) {42}
    Interrupt(ResourceConsumer, Level, ActiveHigh, ExclusiveAndWake) {43}
  }
  Method (_EVT,1) { // Handle all ACPI Events signaled by the Generic
    Event Device(GED1)
    Switch (Arg0) // Arg0 = GSIV of the interrupt
    {
      Case (41) { // interrupt 41
        Store(One, ISTS) // clear interrupt status register at device X
        // which is mapped via an operation region
        Notify (\_SB.DEVX, 0x0) // insertion request
      }
      Case (42) { // interrupt 42
        Notify (\_SB.DEVX, 0x3) // ejection request
      }
      Case (43) { // interrupt 43
```

(continues on next page)

(continued from previous page)

```

        Store(One, ISTS) // clear interrupt status register at device X
        // which is mapped via an operation region
        Notify (\_SB.DEVX, 0x2) // wake event
    }
} //End of Method
} //End of GED1 Scope
Device (\_SB.DEVX)
{
    ...
    Name(_PRW, Package()
    {
        Package(2){ // EventInfo
            \_SB.GED1, // device reference
            0x2 // event (zero-based CRS index) = 2 (maps to interrupt 43)
        },
        0x03, // Can wake up from S3 state
        PWRA // PWRA must be ON for DEVX to wake system
    })
    ...
} //End of DEVX Scope

```

5.6.9.4 GED Wake Events

An important use of the interrupt-signaled events is to implement device wake events. Interrupt-based Wake Events are described in Section 4.1.1.2. Note that the interrupt associated with that wake event must be wake-capable per the Extended Interrupt resource descriptor listed under the `_CRS` object.

Consider the ASL example in the previous section, note that the interrupts that map to the wake event for DEVX are wake-capable. The components of the Interrupt-signaled ACPI event programming model interact in the following way:

- When a device asserts its wake signal and the interrupt has been enabled by the GED driver, the interrupt is asserted.
- If the system is sleeping, this will cause the hardware, if possible, to transition the system into the S0 state.
- Once the system is running, OSPM will dispatch the GED interrupt service routine.
- The GED needs to determine which interrupt has been asserted and may perform a Notify command on the corresponding device object(s) that have asserted wake.
- In turn OSPM will notify OSPM native driver(s) for each device that will wake its device to service it.

Wake events must be exclusively tied to a GED interrupt (for example, one interrupt cannot be shared by multiple wake events) in order to properly handle the semantics used by the system

Note that any ACPI platform may utilize GPIO-signaled and/or Interrupts-signaled ACPI events (i.e. they are not limited to Hardware-reduced ACPI platforms).

5.6.10 Managing a Wake Event Using Device `_PRW` Objects

A device's `_PRW` object provides the zero-based bit index into the general-purpose status register block to indicate which general-purpose status bit from either `GPE0_BLK` or `GPE1_BLK` is used as the specific device's wake mask. Although the hardware must maintain individual device wake enable bits, the system can have multiple devices using the same general-purpose event bit by using OEM-specific hardware to provide second-level status and enable bits. In this case, the OEM AML code is responsible for the second-level enable and status bits.

A device's `_PRW` object provides the zero-based index into the `_AEI` object of a GPIO controller device or zero-based index into the `_CRS` object of a Generic Event Device (GED).

OSPM enables or disables the device wake function by enabling or disabling its corresponding event and by executing its `_PSW` control method (which is used to take care of the second-level enables). When the event is asserted, OSPM still executes the corresponding event control method that determines which device wakes are asserted and notifies the corresponding device objects. The native OS driver is then notified that its device has asserted wake, for which the driver powers on its device to service it.

If the system is in a sleeping state when the enabled event is asserted the hardware will transition the system into the S0 state, if possible.

5.7 Predefined Objects

The AML interpreter of an ACPI compatible operating system supports the evaluation of a number of predefined objects. The objects are considered “built in” to the AML interpreter on the target operating system.

A list of predefined object names are shown in the following table.

Table 5.207: **Predefined Object Names**

Name	Description
<code>_GL</code>	Global Lock mutex
<code>_OS</code>	Name of the operating system
<code>_OSI</code>	Operating System Interface support
<code>_REV</code>	Revision of the ACPI specification that is implemented

5.7.1 `_GL` (Global Lock Mutex)

This predefined object is a Mutex object that behaves like a Mutex as defined in Section 19.6.87, “Mutex (Declare Synchronization/Mutex Object),” with the added behavior that acquiring this Mutex also acquires the shared environment Global Lock defined in Section 5.2.10.1, “Global Lock.” This allows Control Methods to explicitly synchronize with the Global Lock if necessary.

5.7.2 `_OSI` (Operating System Interfaces)

This method is used by the system firmware to query OSPM about interfaces and features that are supported by the host operating system. The usage and implementation model for this method is as follows:

- The `_OSI` method is implemented within the operating system.
- `OSI` is called by the firmware AML code, usually during initialization (such as via `_INI` method). Thus, `_OSI` is actually an “up-call” from the firmware AML to the OS – exactly the opposite of other control methods.
- An `_OSI` invocation by the firmware is a request to the operating system: “Do you support this interface/feature?”

- The host responds to this `_OSI` request with a simple yes or no (Ones/Zero, TRUE/FALSE, Supported/NotSupported).

The `_OSI` method requires one argument and returns an integer. The argument is a string that contains an optional ACPI-defined `OsVendorString` followed by a required `FeatureGroupString`. The feature group string can be either ACPI-defined or OS vendor defined.

`_OSI` cannot and should not be used by the firmware in an attempt to identify the host operating system; rather, this method is intended to be used to identify specific features and interfaces that are supported by the OS. The example below illustrates this:

```
\_OSI ("Windows 2009")
```

In the `_OSI` invocation above, “Windows” is the `OsVendorString`, and “2009” is the vendor-defined `FeatureGroupString`. A return value of TRUE (Ones) from this call does NOT indicate that the executing operating system is Windows. It simply indicates that the actual OS conforms to “Windows 2009” features and interfaces, and is thus compatible with Windows 2009. ACPI implementations other than Windows often reply TRUE to all Windows `_OSI` requests.

The `OsVendorString` should always be accompanied by a `FeatureGroupString`. However, the `OsVendorString` itself is optional and can be omitted if the feature group string applies to all operating systems. The ACPI-defined feature group strings may be used in this standalone manner. For example:

```
\_OSI ("3.0 Thermal Model")
```

Arguments: (1)

Arg0 – A **String** containing the optional OS vendor prefix (as defined in Table 5-186) and/or the required Feature Group string (as ACPI-defined in Table 5-187, or a vendor-defined custom feature/interface string). The optional OS vendor string is not needed in the case of the ACPI-defined feature group strings.

Return Value:

An **Integer** containing a Boolean that indicates whether the requested feature is supported:

0x0 (**Zero**) – The interface, behavior, or feature is not supported

Ones (-1) – The interface, behavior, or feature is supported. Note: The value of Ones is 0xFFFFFFFF in 32-bit mode (DSDT revision 1) or 0xFFFFFFFFFFFFFFFF in 64-bit mode (DSDT revision 2 and greater).

Table 5.208: Predefined Operating System Vendor String Prefixes

Operating System Vendor String Prefix	Description
“FreeBSD” <FeatureGroupString>	Free BSD OS features/interfaces
“HP-UX” <FeatureGroupString>	HP Unix Operating Environment OS features/interfaces
“Linux” <FeatureGroupString>	GNU/Linux Operating system OS features/interfaces
“OpenVMS” <FeatureGroupString>	HP OpenVMS Operating Environment OS features/interfaces
“Windows” <FeatureGroupString>	Microsoft Windows OS features/interfaces

Table 5.209: Standard ACPI-Defined Feature Group Strings

Feature Group String	Description
“Module Device”	OSPM supports the declaration of module device (ACPI0004) in the namespace and will enumerate objects under the module device scope.
“Processor Device”	OSPM supports the declaration of processors in the namespace using the ACPI0007 processor device HID.

continues on next page

Table 5.209 – continued from previous page

Feature Group String	Description
“3.0 Thermal Model”	OSPM supports the extensions to the ACPI thermal model in Revision 3.0.
“Extended Address Space Descriptor”	OSPM supports the Extended Address Space Descriptor
“3.0 _SCP Extensions”	OSPM evaluates _SCP with the additional acoustic limit and power limit arguments defined in ACPI 3.0.
“Processor Aggregator Device”	OSPM supports the declaration of the processor aggregator device in the namespace using the ACPI000C processor aggregator device HID.

OSPM may indicate support for multiple OS interface / behavior strings if the operating system supports the behaviors. For example, a newer version of an operating system may indicate support for strings from all or some of the prior versions of that operating system.

_OSI provides the platform with the ability to support new operating system versions and their associated features when they become available. OSPM can choose to expose new functionality based on the _OSI argument string. That is, OSPM can use the strings passed into _OSI to ensure compatibility between older platforms and newer operating systems by maintaining known compatible behavior for a platform. As such, it is recommended that _OSI be evaluated by the _SB.INI control method so that platform compatible behavior or features are available early in operating system initialization.

Since feature group functionality may be dependent on OSPM implementation, it may be required that OS vendor-defined strings be checked before feature group strings.

Platform developers should consult OS vendor specific information for OS vendor defined strings representing a set of OS interfaces and behaviors. ACPI defined strings representing an operating system and an ACPI feature group are listed in the following tables.

5.7.2.1 _OSI Examples

Use of standard ACPI-defined feature group strings::

```

Scope (_SB)
{
    Name (PAD1, 0)
    Name (MDEV, 0)
    Method (_INI)
    {
        If (CondRefOf (\_OSI) // Ensure \_OSI exists in the OS
        {
            If (\_OSI ("Processor Aggregator Device"))
            {
                Store (1, PAD1)
            }
            If (\_OSI ("Module Device"))
            {
                // Expose PCI Root Bridge under Module Device -
                // OS support Module Device
                Store (0, MDEV1)
                Loadtable ("OEM1", "OEMID", "Table1")
            }
            Else
            {
                // Expose PCI Root Bridge under \_SB -
                // OS does not support Module Device
                Store (1, MDEV1)
            }
        }
    }
}

```

(continues on next page)

(continued from previous page)

```

        Loadtable ("OEM2", "OEMID", "Table2")
    }
}
}
}

```

Use of OS vendor-defined feature group strings:

```

//
// In this example, "Windows" is the OsVendorString, and the year strings
// (2009, 2012, and 2105) are the vendor-defined FeatureGroupStrings
//
Scope (_SB)
{
    Name (OSYS, 0x7D0) // Type of OS indicating supported features
    Method (_INI)
    {
        If (CondRefOf (\_OSI) // Ensure \_OSI exists in the OS
        {
            If (\_OSI ("Windows 2009")
            {
                Store (0x7D1, OSYS)
            }
            If (\_OSI ("Windows 2012")
            {
                Store (0x7D1, OSYS)
            }
            If (\_OSI ("Windows 2015")
            {
                Store (0x7D1, OSYS)
            }
        }
    }
}
}

```

5.7.3 _OS (OS Name Object)

This predefined object evaluates to a string that identifies the operating system. In robust OSPM implementations, _OS evaluates differently for each OS release. This may allow AML code to accommodate differences in OSPM implementations. This value does not change with different revisions of the AML interpreter.

Arguments:

None

Return Value:

A **String** containing the operating system name.

5.7.4 _REV (Revision Data Object)

This predefined object evaluates to an Integer (DWORD) representing the revision of the ACPI Specification implemented by the specified _OS.

Arguments:

None

Return Value:

An **Integer** representing the revision of the currently executing ACPI implementation.

1. Only ACPI 1 is supported, only 32-bit integers.
2. ACPI 2 or greater is supported. Both 32-bit and 64-bit integers are supported.

Actual integer width depends on the revision of the DSDT (revision < 2 means 32-bit. >= 2 means 64-bit).

Other values - Reserved

5.7.5 _DLM (DeviceLock Mutex)

This object appears in a device scope when AML access to the device must be synchronized with the OS environment. It is used in conjunction with a standard Mutex object. With _DLM, the standard Mutex provides synchronization within the AML environment as usual, but also synchronizes with the OS environment.

_DLM evaluates to a package of packages, each containing a reference to a Mutex and an optional resource template protected by the Mutex, If only the Mutex name is specified, then the sharing rules (i.e. which resources are protected by the lock) are defined by a predefined contract between the AML and the OS device driver. If the resource template is specified, then only those resources within the resource template are protected.

Arguments:

None

Return Value:

A variable-length **Package** containing sub-**packages** of Mutex **References** and resource templates. The resource template in each subpackage is optional.

Return Value Information:

```
Package {
    DeviceLockInfo [0] // **Package**
    . . .
    DeviceLockInfo [n] **// Package**
}
```

Each variable-length DeviceLockInfo sub-**Package** contains either one element or 2 elements, as described below:

```
Package {
    DeviceLockMutex // **Reference** to a Mutex object
    Resources // **Buffer** or **Reference** (Resource Template)
}
```

Table 5.210: DeviceLockInfo Package Values

Element	Object Type	Description
DeviceLockMutex	Reference	A reference to the mutex that is to be shared between the AML code and the host operating system.
Resources	<i>Buffer*</i> (or reference to a Buffer)	Optional. Contains a Resource Template that describes the resources that are to be protected by the Device Lock Mutex.

Example:

```

Device (DEV1)
{
  Mutex (MTX1, 0)
  Name (RES1, ResourceTemplate ()
  {
    I2cSerialBusV2 (0x0400, DeviceInitiated, 0x00001000,
      AddressingMode10Bit, "\\_SB.DEV1",
      0, ResourceConsumer, I2C1)
  })

  Name (_DLM, Package (1)
  {
    Package (2)
    {
      MTX1,
      RES1
    }
  })
}

Device (DEV2)
{
  Mutex (MTX2, 0)
  Mutex (MTX3, 0)
  Name (_DLM, Package (2)
  {
    Package (2)
    {
      \\DEV2.MTX2,
      ResourceTemplate ()
      {
        I2cSerialBusV2 (0x0400, DeviceInitiated, 0x00001000,
          AddressingMode10Bit, "\\_SB.DEV2",
          0, ResourceConsumer, I2C2)
      }
    },
    Package (1) // Optional resource not needed
    {
      \\DEV2.MTX3
    }
  })
}

```

5.8 System Configuration Objects

5.8.1 _PIC Method

The _PIC optional method is used to report to the platform runtime firmware the current interrupt model used by the OS. This control method returns nothing. The argument passed into the method signifies the interrupt model OSPM has chosen, PIC mode, APIC mode, or SAPIC mode. Notice that calling this method is optional for OSPM. If the platform CPU architecture supports PIC mode and the method is never called, the platform runtime firmware must assume PIC mode. It is important that the platform runtime firmware save the value passed in by OSPM for later use during wake operations.

Arguments: (1)

Arg0 – An **Integer** containing a code for the current interrupt model:

0 - PIC mode
1 - APIC mode
2 - SAPIC mode
Other values - Reserved

Return Value:

None

DEVICE CONFIGURATION

This section specifies the objects OSPM uses to configure devices. There are three types of configuration objects:

- Device identification objects associate platform devices with Plug and Play IDs.
- Device configuration objects declare and configure hardware resources and characteristics for devices enumerated via ACPI.
- Device insertion and removal objects provide mechanisms for handling dynamic insertion and removal of devices.

There are two types of Device objects:

- A Full Device Descriptor, which contains the complete description of a devices that cannot be discovered through any other standard Bus enumeration mechanism. This type of Device object is enumerated by the ACPI subsystem (OSPM), and contains a Hardware ID object (`_HID`).
- An Agumented Device Descriptor, which contains additional device information that is not provided from the Device itself, yet is needed by the Device or Bus driver in order to properly configure and use the device. This type of device is enumerated by a bus-specific enumeration mechanism, and OSPM uses the Address (`_ADR`) to match the ACPI Device object in the Namespace to the device discovered through bus enumeration.

This section also defines the ACPI device-resource descriptor formats. Device-resource descriptors are used as parameters by some of the device configuration objects.

6.1 Device Identification Objects

Device identification objects associate each platform device with a Plug and Play device ID for each device. All the device identification objects are listed in the table below:

Table 6.1: **Device Identification Objects**

Object	Description
<code>_ADR</code>	Object that evaluates to a device's address on its parent bus.
<code>_CID</code>	Object that evaluates to a device's Plug and Play-compatible ID list.
<code>_CLS</code>	Object that evaluates to a package of coded device-class information.
<code>_DDN</code>	Object that associates a logical software name (for example, COM1) with a device.
<code>_HID</code>	Object that evaluates to a device's Plug and Play hardware ID.
<code>_HRV</code>	Object that evaluates to an integer hardware revision number.
<code>_MLS</code>	Object that provides a human readable description of a device in multiple languages.
<code>_PLD</code>	Object that provides physical location description information.
<code>_SUB</code>	Object that evaluates to a device's Plug and Play subsystem ID.
<code>_SUN</code>	Object that evaluates to the slot-unique ID number for a slot.

continues on next page

Table 6.1 – continued from previous page

_STR	Object that contains a Unicode identifier for a device. Can also be used for thermal zones.
_UID	Object that specifies a device’s unique persistent ID, or a control method that generates it.

For any device that is on a non-enumerable type of bus (for example, an ISA bus), OSPM enumerates the devices’ identifier(s) and the ACPI system firmware must supply an _HID object (plus one or more optional objects such as _CID, _CLS, _HRV, _SUB) for each device to enable OSPM to do that. For devices on an enumerable type of bus, such as a PCI bus, the ACPI system must identify which device on the enumerable bus is identified by a particular address; the ACPI system firmware must supply an _ADR object for each device to enable this. A device object must contain either an _HID object or an _ADR object, but must not contain both.

If any of these objects are implemented as control methods, these methods may depend on operation regions. Since the control methods may be evaluated before an operation region provider becomes available, the control method must be structured to execute in the absence of the operation region provider. (_REG methods notify the platform runtime firmware of the presence of operation region providers.) When a control method cannot determine the current state of the hardware due to a lack of operation region provider, it is recommended that the control method should return the condition that was true at the time that control passed from the platform boot firmware to the OS. (The control method should return a default, boot value).

6.1.1 _ADR (Address)

This object is used to supply OSPM with the address of a device on its parent bus. An _ADR object must be used when specifying the address of any device on a bus that has a standard enumeration algorithm (see *Configuration and “Plug and Play”*, for the situations when these devices do appear in the ACPI namespace). The _ADR object is valid only within an Augmented Device Descriptor.

Arguments:

None

Return Value:

An **Integer** containing the address of the device

An _ADR object can be used to provide capabilities to the specified address even if a device is not present. This allows the system to provide capabilities to a slot on the parent bus.

OSPM infers the parent bus and segment from the location of the _ADR object’s device package in the ACPI namespace. For more information about the positioning of device packages in the ACPI namespace, see *Device (Declare Device Package)*

_ADR object information must be static and can be defined for the following bus types listed in *ADR Object Address Encodings*.

Table 6.2: ADR Object Address Encodings

BUS	Address Encoding
EISA	EISA slot number 0-F
Floppy Bus	Drive select values used for programming the floppy controller to access the specified INT13 unit number. The _ADR Objects should be sorted based on drive select encoding from 0-3.

continues on next page

Table 6.2 – continued from previous page

I3C	Bits [63:52] - Reserved Bits [51:48] - Master Instance Bits [47:0] - I3C Device Provisional ID, following encoding defined in the MIPI Specification for I3C . If an I3C device supports a static address instead of a Provisional ID, then bits [47:7] are Reserved (zero), and bits [6:0] are the 7-bit static address.
IDE Controller	0-Primary Channel, 1-Secondary Channel
IDE Channel	0-Master drive, 1-Slave drive
Intel® High Definition Audio	High word - SDI (Serial Data In) ID of the codec that contains the function group. Low word - Node ID of the function group.
PCI	High word-Device #, Low word-Function #. (for example, device 3, function 2 is 0x00030002). To refer to all the functions on a device #, use a function number of FFFF).
PCMCIA	Socket #; 0-First Socket
PC CARD	Socket #; 0-First Socket
Serial ATA	SATA Port: High word–Root port #, Low word–port number off of a SATA port multiplier, or 0xFFFF if no port multiplier attached. (For example, root port 2 would be 0x0002FFFF. If instead a port multiplier had been attached to root port 2, the ports connected to the multiplier would be encoded 0x00020000, 0x00020001, etc.) The value 0xFFFFFFFF is reserved.
SMBus	Lowest Slave Address
USB Root HUB	Only one child of the host controller. It must have an _ADR of 0. No other children or values of _ADR are allowed.
USB Ports	Port number (1-n)
SDIO Bus	High word - Slot number (0-First Slot) Low word - Function number (see SD specification for definitions.)
NVDIMM	NFIT Device handle as defined by the NVDIMM Region Mapping Structure

6.1.2 _CID (Compatible ID)

This optional object is used to supply OSPM with a device’s Plug and Play-Compatible Device ID. Use _CID objects when a device has no other defined hardware standard method to report its compatible IDs. The _CID object is valid only within a Full Device Descriptor. An _HID object must also be present.

Arguments:

None

Return Value:

An **Integer** or **String** containing a single CID *or* a **Package** containing a list of CIDs

A _CID object evaluates to either:

- A single Compatible Device ID
- A package of Compatible Device IDs for the device – in the order of preference, highest preference first.

Each Compatible Device ID must be either:

- A valid HID value (a 32-bit compressed EISA type ID or a string such as “ACPI0004”).
- A string that uses a bus-specific nomenclature. For example, _CID can be used to specify the PCI ID. The format of a PCI ID string is one of the following:

```
"PCI\CC_ccss"
"PCI\CC_ccssp"
"PCI\VEN_vvvv&DEV_dddd&SUBSYS_ssssssss&REV_rr"
"PCI\VEN_vvvv&DEV_dddd&SUBSYS_ssssssss"
"PCI\VEN_vvvv&DEV_dddd&REV_rr"
"PCI\VEN_vvvv&DEV_dddd"
```

Where:

```
cc      - hexadecimal representation of the Class Code byte
ss      - hexadecimal representation of the Subclass Code byte
pp      - hexadecimal representation of the Programming Interface byte
vvvv    - hexadecimal representation of the Vendor ID
dddd    - hexadecimal representation of the Device ID
sssssss - hexadecimal representation of the Subsystem ID
rr      - hexadecimal representation of the Revision byte
```

A compatible ID retrieved from a `_CID` object is only meaningful if it is a non-NULL value.

Example ASL:

```
Device (XYZ) {
    Name (_HID, EISAID ("PNP0303")) // PC Keyboard Controller
    Name (_CID, EISAID ("PNP030B"))
}
```

6.1.3 `_CLS` (Class Code)

This object is used to supply OSPM with the PCI-defined base-class, sub-class and programming interface for a device. This object is optional. However, it may be useful for loading generic drivers on hardware that is compatible with PCI-defined device classes, but that is not implemented on the PCI bus (and is therefore enumerated by ACPI.)

Arguments:

None

Return Value:

A **Package** containing the PCI-defined class information as a list of **Integers**:

```
Package(3) {<base-class code>, <sub-class code>, <Programming Interface code>
→}
```

A list of available class codes and programming interface codes is provided by the PCI SIG. See “PCI Code and ID Assignment Specification”, available from “Links to ACPI-Related Documents” (<http://uefi.org/acpi>) under the heading “PCI Code and ID Assignment Specification

Example ASL:

```
Device(SATA) //AHCI- compatible SATA controller
{
    Name(_HID, "...")
    Name(_CLS, Package (3)
        {
            0x01, // Base Class (01h == Mass Storage)
            0x06, // Sub-Class (06h == SATA)
            0x01, // Programming Interface (01h == AHCI)
```

(continues on next page)

(continued from previous page)

```

    })
    Name(_CRS, ResourceTemplate()
    {
        ... // AHCI-defined system resources
    })
}

```

6.1.4 _DDN (DOS Device Name)

This object is used to associate a logical name (for example, COM1) with a device. This name can be used by applications to connect to the device.

Arguments:

None

Return Value:

A **String** containing the DOS device name

6.1.5 _HID (Hardware ID)

This object is used to supply OSPM with the device's PNP ID or ACPI ID.

See also:

PNP ID and ACPI ID Registry is at http://www.uefi.org/PNP_ACPI_Registry.

When describing a platform, use of any _HID objects is optional. However, a _HID object must be used to describe any device that will be enumerated by OSPM. OSPM only enumerates a device when no bus enumerator can detect the device ID. For example, devices on an ISA bus are enumerated by OSPM. Use the _ADR object to describe devices enumerated by bus enumerators other than OSPM. The _HID object is valid only within a Full Device Descriptor.

Arguments:

None

Return Value:

An **Integer** or **String** containing the HID

A _HID object evaluates to either a numeric 32-bit compressed EISA type ID or a string. If a string, the format must be an alphanumeric PNP or ACPI ID with no asterisk or other leading characters.

A valid PNP ID must be of the form "AAA####" where A is an uppercase letter and # is a hex digit. A valid ACPI ID must be of the form "NNNN####" where N is an uppercase letter or a digit ('0'-'9') and # is a hex digit. This specification reserves the string "ACPI" for use only with devices defined herein. It further reserves all strings representing 4 HEX digits for exclusive use with PCI-assigned Vendor IDs.

Example ASL:

```

Name (_HID, EISAID ("PNP0C0C")) // Control-Method Power Button
Name (_HID, EISAID ("INT0800")) // Firmware Hub
Name (_HID, "ACPI0003") // AC adapter device
Name (_HID, "MSFT0003") // Vendor-defined device
Name (_HID, "80860003") // PCI-assigned device identifier

```

6.1.6 _HRV (Hardware Revision)

This object is used to supply OSPM with the device's hardware revision. The use of _HRV is optional.

Arguments:

None

Return Value:

An **Integer (DWORD)** containing the hardware revision number

Example ASL:

```
Name (_HRV, 0x0003) // Revision number 3 of this hardware device
```

6.1.7 _MLS (Multiple Language String)

The _MLS object provides OSPM a human readable description of a device in multiple languages. This information may be provided to the end user when the OSPM is unable to get any other information about this device. Although this functionality is also provided by the _STR object, _MLS expands that functionality and provides vendors with the capability to provide multiple strings in multiple languages. The _MLS object evaluates to a package of packages. Each sub-package consists of a Language identifier and corresponding unicode string for a given locale. Specifying a language identifier allows OSPM to easily determine if support for displaying the Unicode string is available. OSPM can use this information to determine whether or not to display the device string, or which string is appropriate for a user's preferred locale.

It is assumed that OSPM will always support the primary English locale to accommodate English embedded in a non-English string, such as a brand name.

If OSPM doesn't support the specific sub-language ID it may choose to use the primary language ID for displaying device text.

Arguments:

None

Return Value:

A variable-length **Package** containing a list of language descriptor **Packages** as described below.

Return Value Information:

```
Package {
    LanguageDescriptor[0] // Package
    LanguageDescriptor[n] // Package
}
```

Each Language Descriptor sub-Package contains the elements described below:

```
Package {
    LanguageId // String
    UnicodeDescription // Buffer
}
```

LanguageId is a string identifying the language. This string follows the format specified in the Internet RFC 3066 document (Tags for the Identification of Languages). In addition to supporting the existing strings in RFC 3066, the table below lists aliases that are also supported.

Table 6.3: Additional Language ID Alias Strings

RFC String	Supported Alias String
zh-Hans	zh-chs
zh-Hant	zh-cht

UnicodeDescription is a Buffer containing a Unicode (UTF-16) string. This string contains the language-specific description of the device corresponding to the LanguageID. The Unicode() ASL macro can be used to create this Buffer.

Example:

```
Device (XYZ) {
    Name (_ADR, 0x00020001)
    Name ( \_MLS, Package () { (2) { "en", Unicode ("ACME super DVD controller") } })
}
```

6.1.8 _PLD (Physical Location of Device)

This optional object is a method that conveys to OSPM a general description of the physical location of a device’s external connection point. The _PLD may be child object for any ACPI Namespace object the system wants to describe. This information can be used by system software to describe to the user which specific connector or device input mechanism may be used for a given task or may need user intervention for correct operation. The _PLD should only be evaluated when its parent device is present as indicated by the device’s presence mechanism (i.e. _STA or other)

An externally exposed device connection point can reside on any surface of a system’s housing. The respective surfaces of a system’s housing are identified by the “Panel” field (described below). The _PLD method returns data to describe the location of where the device’s connection point resides and a Shape (described below) that may be rendered at that position. One physical device may have several connection points. A _PLD describes the offset and rotation of a single device connection point from an “origin” that resides in the lower left hand corner of its Panel.

All Panel references (Top, Bottom, Right, Left, etc.) are interpreted as though the user is facing the front of the system. For handheld mobile devices, the front panel is the one holding the display screen, and its origin is in the lower-left corner when the display is viewed in the Portrait orientation. For example, the Right Panel is the right side of the system as viewed from the front.

All “origin” references for a Panel are interpreted as its lower left corner when the user is facing the respective Panel. The Top Panel shall be viewed with the system is viewed resting on its Front Panel, and the Bottom Panel shall be viewed with the system resting on its Back Panel. All other Panels shall be viewed with the system resting on its Bottom Panel. See *System Panel and Panel Origin Positions* for more information.

The data bits also assume that if the system is capable of opening up like a laptop that the device may exist on the base of the laptop system or on the lid. In the case of the latter, the “Lid” bit (described below) should be set indicating the device connection point is on the lid. If the device is on the lid, the description describes the device’s connection point location when the system is opened with the lid up. If the device connection point is not on the lid, then the description describes the device’s connection point location when the system with the lid closed.

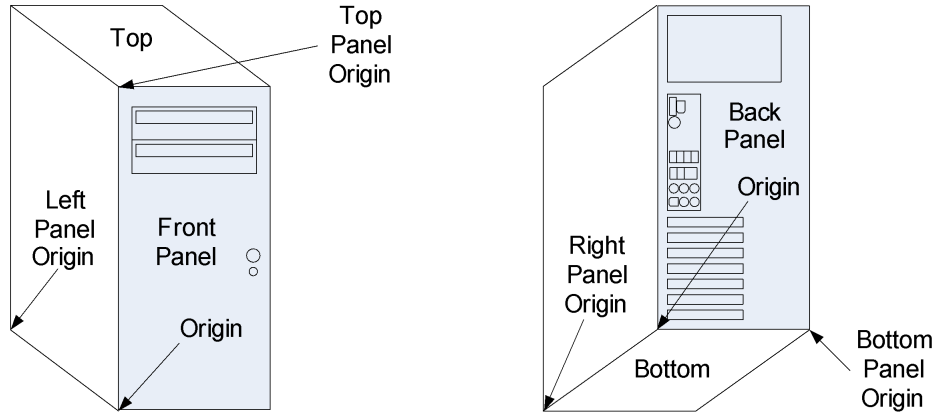

Fig. 6.1: System Panel and Panel Origin Positions

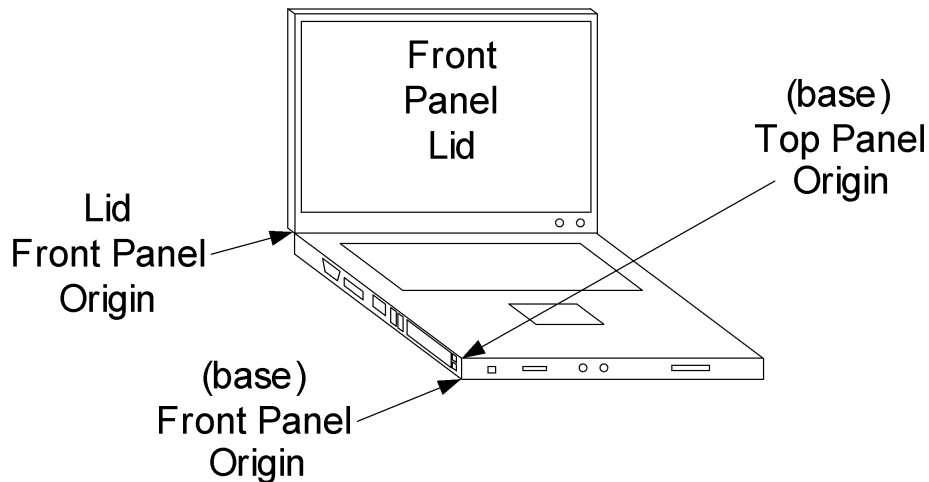

Fig. 6.2: Laptop Panel and Panel Origin Positions

To render a view of a system Panel, all `_PLDs` that define the same Panel and Lid values are collected. The `_PLDs` are then sorted by the value of their Order field and the view of the panel is rendered by drawing the shapes of each connection point (in their correct Shape, Color, Horizontal Offset, Vertical Offset, Width, Height, and Orientation) starting with all Order = 0 `_PLDs` first. Refer to *PLD Back Panel Rendering* for an example.

The location of a device connection point may change as a result of the system connecting or disconnecting to a docking station or a port replicator. As such, Notify event of type 0x09 will cause OSPM to re-evaluate the `_PLD` object residing under the particular device notified. If a platform is unable to detect the change of connecting or disconnecting to a docking station or port replicator, a `_PLD` object should not be used to describe the device connection points that will change location after such an event.

Arguments:

None

Return Value:

A variable-length **Package** containing a list of **Buffers**

This method returns a **package** containing a single or multiple buffer entries. At least one buffer entry must be returned using the bit definitions below.

Table 6.4: _PLD Buffer 0 Return Value

Name	Definition	DWORD	Bit Offset (DWORD)	Bit Offset (Buffer)	Length (bits)
Revision	The current Revision is 0x2	0	0	0	7
Ignore Color	If this bit is set, the Color field is ignored, as the color is unknown.	0	7	7	1
Color	24-bit RGB value for the color of the device connection point: Bits [7:0]=red value Bits [15:8]=green value Bits [23:16]=blue value	0	8	8	24
Width	Width of the widest point of the device connection point, in millimeters	1	0	32	16
Height	Height of the tallest point of the device connection point, in millimeters	1	16	48	16
User Visible	Set if the device connection point can be seen by the user without disassembly.	2	0	64	1
Dock	Set if the device connection point resides in a docking station or port replicator.	2	1	65	1
Lid	Set if this device connection point resides on the lid of laptop system.	2	2	66	1
Panel	Describes which panel surface of the system's housing the device connection point resides on: 0 - Top 1 - Bottom 2 - Left 3 - Right 4 - Front 5 - Back 6 - Unknown (Vertical Position and Horizontal Position will be ignored)	2	3	67	3
Vertical Position on the panel where the device connection point resides	0 - Upper 1 - Center 2 - Lower	2	6	70	2
Horizontal Position on the panel where the device connection point resides.	0 - Left 1 - Center 2 - Right	2	8	72	2

continues on next page

Table 6.4 – continued from previous page

Shape	Describes the shape of the device connection point. The Width and Height fields may be used to distort a shape, e.g. A Round shape will look like an Oval shape if the Width and Height are not equal. And a Vertical Rectangle or Horizontal Rectangle may look like a square if Width and Height are equal. See <i>Default Shape Definitions</i> : 0 - Round 1 - Oval 2 - Square 3 - Vertical Rectangle 4 - Horizontal Rectangle 5 - Vertical Trapezoid 6 - Horizontal Trapezoid 7 - Unknown - Shape rendered as a Rectangle with dotted lines 8 - Chamfered 15:9 - <i>Reserved</i>	2	10	74	4
Group Orientation	if Set, indicates vertical grouping, otherwise horizontal is assumed.	2	14	78	1
Group Token	Unique numerical value identifying a group.	2	15	79	8
Group Position	Identifies this device connection point's position in the group (i.e. 1st, 2nd)	2	23	87	8
Bay	Set if describing a device in a bay or if device connection point is a bay.	2	31	95	1
Ejectable	Set if the device is ejectable. Indicates ejectability in the absence of _EJx objects.	3	0	96	1
OSPM Ejection required	OSPM Ejection required: Set if OSPM needs to be involved with ejection process. User-operated physical hardware ejection is not possible.	3	1	97	1
Cabinet Number	For single cabinet system, this field is always 0.	3	2	98	8
Card Cage Number	For single card cage system, this field is always 0.	3	10	106	8
Reference	if Set, this _PLD defines a "reference" shape that is used to help orient the user with respect to the other shapes when rendering _PLDs.	3	18	114	1

continues on next page

Table 6.4 – continued from previous page

Rotation	Rotates the Shape clockwise in 45 degree steps around its origin where: 0 - 0° 1 - 45° 2 - 90° 3 - 135° 4 - 180° 5 - 225° 6 - 270° 7 - 315°	3	19	115	4
Order	Identifies the drawing order of the connection point described by a <u>_PLD</u> : Order = 0 connection points are drawn before Order = 1 connection points. Order = 1 before Order = 2, and so on. Order = 31 connection points are drawn last. Order should always start at 0 and be consecutively assigned.	3	23	119	5
Reserved	Reserved, must contain a value of 0.	3	28	124	4
Vertical Offset	Offset of Shape Origin from Panel Origin (0.1 mm / 100 microns). A value of 0xFFFFFFFF indicates that this field is not supplied.	4	0	128	16
Horizontal Offset	Offset of Shape Origin from Panel Origin (0.1 mm / 100 microns). A value of 0xFFFFFFFF indicates that this field is not supplied.	4	16	144	16

Note: All additional buffer entries returned may contain OEM-specific data, but must begin in a {GUID, data} pair. These additional data may provide complimentary physical location information specific to certain systems or class of machines.

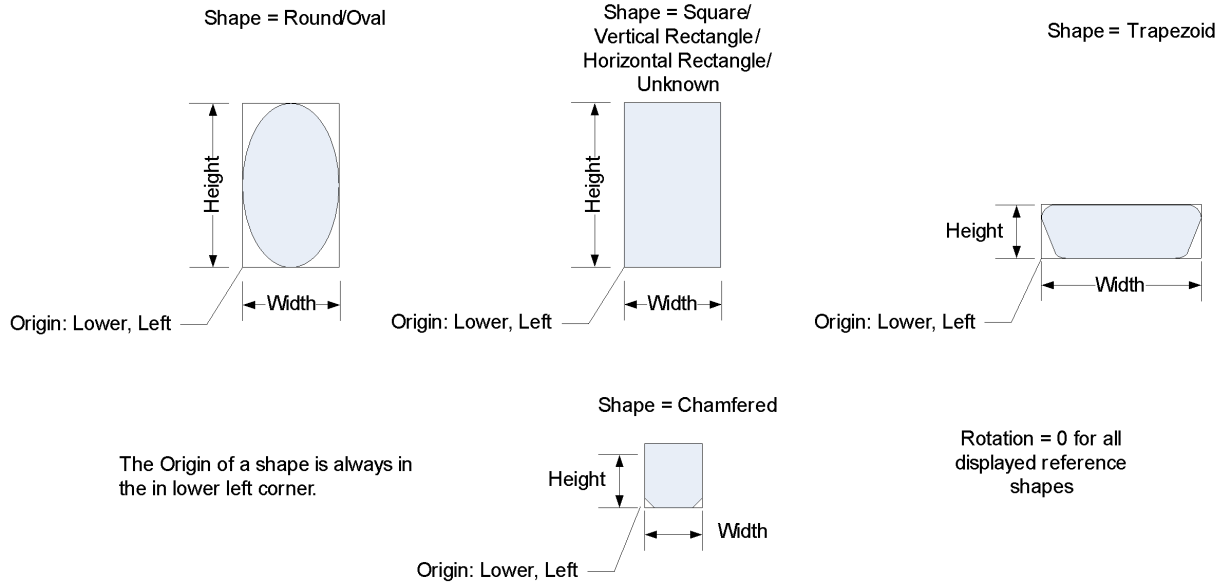

Fig. 6.3: Default Shape Definitions

Buffers 1–N Return Value (Optional):

- Buffer 1 Bit [127:0] - GUID 1
- Buffer 2 Bit [127:0] - Data 1
- Buffer 3 Bit [127:0] - GUID 2
- Buffer 4 Bit [127:0] - Data 2
- etc.

PLD Back Panel Rendering provides an example of a rendering of the external device connection points that may be conveyed to the user by `_PLD` information. Note that three `_PLDs` (System Back Panel, Power Supply, and Motherboard (MB) Connector Area) that are associated with the System Bus tree (`_SB`) object. Their Reference flag is set indicating that are used to provide the user with visual queues for identifying the relative locations of the other device connection points.

The connection points (C1 through C16) are defined by `_PLD` objects found in the System bus tree.

The following connection points all have their Panel and Lid fields set to Back and 0, respectively. And the Reference flag of the System Back Panel, Power Supply, and MB Connector Area connection points are set to 1. in this example are used to render *PLD Back Panel Rendering*:

Table 6.5: **PLD Back Panel Example Settings**

Name	Ignore Color	R	G	B	Width	Height	VOff	HOff	Shape	Notation	Goup Position	Rotation
Back Panel	Yes	0	0	0	203	432	0	0	V Rect		1	0
MB Conn area	Yes	0	0	0	45	156	159	13	V Rect		2	0

continues on next page

Table 6.5 – continued from previous page

Power Supply	Yes	0	0	0	152	890	330	13	H Rect		2	0
USB Port 1	No	0	0	0	13	5	222	16	H Rect	C1	3	90
USB Port 2	No	0	0	0	13	5	222	25	H Rect	C2	3	90
USB Port 3	No	0	0	0	13	5	222	35	H Rect	C3	3	90
USB Port 4	No	0	0	0	13	5	222	45	H Rect	C4	3	90
USB Port 5	No	0	0	0	13	5	201	16	H Rect	C5	3	90
USB Port 6	No	0	0	0	13	5	201	25	H Rect	C6	3	90
Ethernet	No	0	0	0	16	17	201	35	V Rect	C7	3	90
Audio 1	No	FF	FF	FF	13	13	195	15	Round	C8	3	90
Audio 2	No	151	247	127	13	13	195	29	Round	C9	3	90
Audio 3	No	0	0	0	13	13	195	48	Round	C10	3	90
SPDIF	No	0	0	0	11	13	176	18	V Trap	C11	3	90
Audio 4	No	0	FF	0	13	13	177	29	Round	C12	3	90
Audio 5	No	0	0	FF	13	13	177	43	Round	C13	3	90
SATA	No	0	0	0	24	9	309	16	H Rect	C14	3	90
1394	No	0	0	0	11	16	289	25	H Trap	C15	3	0
Coax	No	0	0	0	16	16	284	14	Round	C16	3	90
PCI 1	No	0	0	0	102	13	13	13	H Rect	1	3	0
PCI 2	No	0	0	0	102	13	33	13	H Rect	2	3	0
PCI 3	No	0	0	0	102	13	54	13	H Rect	3	3	0
PCI 4	No	0	0	0	102	13	75	13	H Rect	4	3	0
PCI 5	No	0	0	0	102	13	95	13	H Rect	5	3	0
PCI 6	No	0	0	0	102	13	116	13	H Rect	6	3	0
PCI 7	No	0	0	0	102	13	137	13	H Rect	7	3	0

Note that the origin is in the lower left hand corner of the Back Panel, where positive Horizontal and Vertical Offset values are to the right and up, respectively.

6.1.9 _SUB (Subsystem ID)

This object is used to supply OSPM with the device's Subsystem ID. The use of _SUB is optional.

Arguments:

None

Return Value:

A String containing the SUB

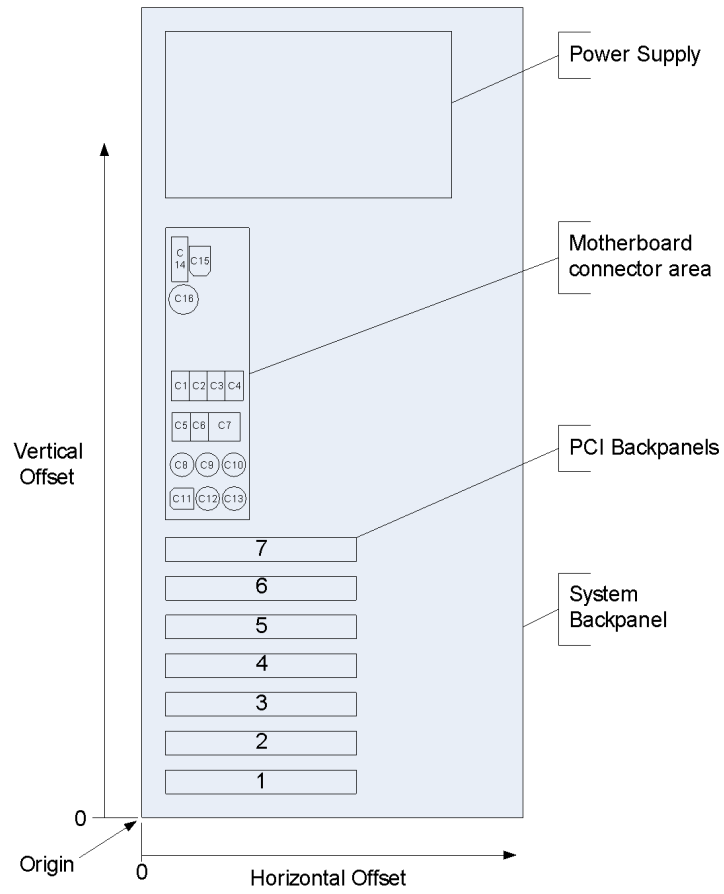

Fig. 6.4: PLD Back Panel Rendering

A `_SUB` object evaluates to a string and the format must be a valid PNP or ACPI ID with no asterisk or other leading characters.

See the definition of `_HID` (*`_HID (Hardware ID)`*) for the definition of PNP and ACPI ID strings.

Example ASL:

```
Name (_SUB, "MSFT3000") // Vendor-defined subsystem
```

6.1.10 `_STR` (String)

The `_STR` object evaluates to a Unicode string that describes the device or thermal zone. It may be used by an OS to provide information to an end user. This information is particularly valuable when no other information is available.

Arguments:

None

Return Value:

A **Buffer** containing a Unicode string that describes the device

Example ASL:

```
Device (XYZ) {
    Name (_ADR, 0x00020001)
    Name (_STR, Unicode ("ACME super DVD controller"))
}
```

Then, when all else fails, an OS can use the info included in the `_STR` object to describe the hardware to the user.

6.1.11 `_SUN` (Slot User Number)

`_SUN` is an object that evaluates to the slot-unique ID number for a slot. `_SUN` is used by OSPM UI to identify slots for the user. For example, this can be used for battery slots, PCI slots, PCMCIA slots, or swappable bay slots to inform the user of what devices are in each slot. `_SUN` evaluates to an integer that is the number to be used in the user interface.

Arguments:

None

Return Value:

An **Integer** containing the slot's unique ID

The `_SUN` value is required to be unique among the slots of the same type. It is also recommended that this number match the slot number printed on the physical slot whenever possible.

6.1.12 _UID (Unique ID)

This object provides OSPM with a logical device ID that does not change across reboots. This object is optional, but is required when the device has no other way to report a persistent unique device ID. The _UID must be unique across all devices with either a common _HID or _CID. This is because a device needs to be uniquely identified to the OSPM, which may match on either a _HID or a _CID to identify the device. The uniqueness match must be true regardless of whether the OSPM uses the _HID or the _CID. OSPM typically uses the unique device ID to ensure that the device-specific information, such as network protocol binding information, is remembered for the device even if its relative location changes. For most integrated devices, this object contains a unique identifier.

In general, a _UID object evaluates to either a numeric value or a string. However, when defining an object with an _HID of ACPI0007 (processor definition objects), the _UID object must return an integer. This integer is used as an identifier in the MADT, PPTT and other tables to connect non-enumerable devices to a processor object. When a string is used in these cases, there is no mechanism for connecting these devices.

Arguments:

None

Return Value:

An **Integer** or **String** containing the Unique ID

6.2 Device Configuration Objects

This section describes objects that provide OSPM with device specific information and allow OSPM to configure device operation and resource utilization.

OSPM uses device configuration objects to configure hardware resources for devices enumerated via ACPI. Device configuration objects provide information about current and possible resource requirements, the relationship between shared resources, and methods for configuring hardware resources.

Note: these objects must only be provided for devices that cannot be configured by any other hardware standard such as PCI, PCMCIA, and soon.

When OSPM enumerates a device, it calls _PRS to determine the resource requirements of the device. It may also call _CRS to find the current resource settings for the device. Using this information, the Plug and Play system determines what resources the device should consume and sets those resources by calling the device's _SRS control method.

In ACPI, devices can consume resources (for example, legacy keyboards), provide resources (for example, a proprietary PCI bridge), or do both. Unless otherwise specified, resources for a device are assumed to be taken from the nearest matching resource above the device in the device hierarchy.

Some resources, however, may be shared amongst several devices. To describe this, devices that share a resource (resource consumers) must use the extended resource descriptors (0x7-0xA) described in *Large Resource Data Type*. These descriptors point to a single device object (resource producer) that claims the shared resource in its _PRS. This allows OSPM to clearly understand the resource dependencies in the system and move all related devices together if it needs to change resources. Furthermore, it allows OSPM to allocate resources only to resource producers when devices that consume that resource appear.

The device configuration objects are listed in the table below.

Table 6.6: Device Configuration Objects

Object	Description
--------	-------------

continues on next page

Table 6.6 – continued from previous page

_CCA	Cache Coherency Attribute – specifies whether a device and its descendants support hardware managed cache coherency.
_CDM	Object that specifies a clock domain for a processor.
_CRS	Object that specifies a device’s current resource settings, or a control method that generates such an object.
_DIS	Control method that disables a device.
_DMA	Object that specifies a device’s current resources for DMA transactions.
_DSD	Object that evaluates to device specific information
_FIX	Object used to provide correlation between the fixed-hardware register blocks defined in the FADT and the devices that implement these fixed-hardware registers.
_GSB	Object that provides the Global System Interrupt Base for a hot-plugged I/O APIC device.
_HMA	Object that provides updated HMAT structures.
_HPP	Object that specifies the cache-line size, latency timer, SERR enable, and PERR enable values to be used when configuring a PCI device inserted into a hot-plug slot or initial configuration of a PCI device at system boot.
_HPX	Object that provides device parameters when configuring a PCI device inserted into a hot-plug slot or initial configuration of a PCI device at system boot. Supersedes _HPP.
_MAT	Object that evaluates to a buffer of Interrupt Controller Structures.
_OSC	An object OSPM evaluates to convey specific software support / capabilities to the platform allowing the platform to configure itself appropriately.
_PRS	An object that specifies a device’s possible resource settings, or a control method that generates such an object.
_PRT	Object that specifies the PCI interrupt routing table.
_PXM	Object that specifies a proximity domain for a device.
_SLI	Object that provides updated distance information for a system locality.
_SRS	Control method that sets a device’s settings.

6.2.1 _CDM (Clock Domain)

This optional object conveys the processor clock domain to which a processor belongs. A processor clock domain is a unique identifier representing the hardware clock source providing the input clock for a given set of processors. This clock source drives software accessible internal counters, such as the Time Stamp Counter, in each processor. Processor counters in the same clock domain are driven by the same hardware clock source. In multi-processor platforms that utilize multiple clock domains, such counters may exhibit drift when compared against processor counters on different clock domains.

The _CDM object evaluates to an integer that identifies the device as belonging to a specific clock domain. OSPM assumes that two devices in the same clock domain are connected to the same hardware clock.

Arguments:

None

Return Value:

An **Integer** (DWORD) containing a clock domain identifier.

In the case the platform does not convey any clock domain information to OSPM via the SRAT or the _CDM object, OSPM assumes all logical processors to be on a common clock domain. If the platform defines _CDM object under a logical processor then it must define _CDM objects under all logical processors whose clock domain information is not provided via the SRAT.

6.2.2 **_CRS (Current Resource Settings)**

This required object evaluates to a byte stream that describes the system resources currently allocated to a device. Additionally, a bus device must supply the resources that it decodes and can assign to its children devices. If a device is disabled, then `_CRS` returns a valid resource template for the device, but the actual resource assignments in the return byte stream are ignored. If the device is disabled when `_CRS` is called, it must remain disabled.

The format of the data contained in a `_CRS` object follows the formats defined in *Resource Data Types for ACPI*, which is a compatible extension of the Plug and Play BIOS Specification (see reference below). The resource data is provided as a series of data structures, with each of the resource data structures having a unique tag or identifier. The resource descriptor data structures specify the standard PC system resources, such as memory address ranges, I/O ports, interrupts, and DMA channels.

Arguments:

None

Return Value:

A **Buffer** containing a resource descriptor byte stream

A link to the *Plug and Play BIOS Specification* can be found at <http://uefi.org/acpi> under the heading “Plug and Play BIOS Specification.”

Also see the related link on the above website for the *Windows Generic Device IDs and Plug and Play BIOS device type codes*.

6.2.3 **_DIS (Disable)**

This control method disables a device. When the device is disabled, it must not be decoding any hardware resources. Prior to running this control method, OSPM will have already put the device in the D3 state.

When a device is disabled via `_DIS`, the `_STA` control method for this device must return with the Enabled bit (Bit 1) clear.

Arguments:

None

Return Value:

None

6.2.4 **_DMA (Direct Memory Access)**

This optional object returns a byte stream in the same format as a `_CRS` object. `_DMA` is only defined under devices that represent buses. It specifies the ranges the bus controller (bridge) decodes on the child-side of its interface. (This is analogous to the `_CRS` object, which describes the resources that the bus controller decodes on the parent-side of its interface.) Any ranges described in the resources of a `_DMA` object can be used by child devices for DMA or bus master transactions.

The `_DMA` object is only valid if a `_CRS` object is also defined. OSPM must re-evaluate the `_DMA` object after an `_SRS` object has been executed because the `_DMA` ranges resources may change depending on how the bridge has been configured.

If the `_DMA` object is not present for a bus device, the OS assumes that any address placed on a bus by a child device will be decoded either by a device on the bus or by the bus itself, (in other words, all address ranges can be used for DMA).

For example, if a platform implements a PCI bus that cannot access all of physical memory, it has a `_DMA` object under that PCI bus that describes the ranges of physical memory that can be accessed by devices on that bus.

A `_DMA` object is not meant to describe any “map register” hardware that is set up for each DMA transaction. It is meant only to describe the DMA properties of a bus that cannot be changed without reevaluating the `_SRS` method.

Arguments:

None

Return Value:

A **Buffer** containing a resource descriptor byte stream

`_DMA` Example ASL:

```
Device (BUS0)
{
    //
    // The _DMA method returns a resource template describing the
    // addresses that are decoded on the child side of this
    // bridge. The contained resource descriptors thus indicate
    // the address ranges that bus masters living below this
    // bridge can use to send accesses through the bridge toward a
    // destination elsewhere in the system (e.g. main memory).
    //
    // In our case, any bus master addresses need to fall between
    // 0 and 0x80000000 and will have 0x200000000 added as they
    // cross the bridge. Furthermore, any child-side accesses
    // falling into the range claimed in our _CRS will be
    // interpreted as a peer-to-peer traffic and will not be
    // forwarded upstream by the bridge.
    //
    // Our upstream address decoder will only claim one range from
    // 0x200000000 to 0x5fffffff in the _CRS. Therefore _DMA
    // should return two QWORDMemory descriptors, one describing
    // the range below and one describing the range above this
    // "peer-to-peer" address range.
    //
    Method(_DMA, ResourceTemplate()
    {
        QWORDMemory (
            ResourceProducer,
            PosDecode, // _DEC
            MinFixed, // _MIF
            MaxFixed, // _MAF
            Prefetchable, // _MEM
            ReadWrite, // _RW
            0, // _GRA
            0, // _MIN
            0x1fffffff, // _MAX
            0x200000000, // _TRA
            0x200000000, // _LEN
            ,
            ,
            ,
        )
        QWORDMemory (
            ResourceProducer,
            PosDecode, // _DEC
```

(continues on next page)

(continued from previous page)

```

MinFixed, // _MIF
MaxFixed, // _MAF
Prefetchable, // _MEM
ReadWrite, // _RW
0, // _GRA
0x60000000, // _MIN
0x7fffffff, // _MAX
0x200000000, // _TRA
0x20000000, // _LEN
,
,
,
)
})
}

```

6.2.5 _DSD (Device Specific Data)

This optional object is used to provide device drivers (via OSPM) with additional device properties and information. `_DSD` returns a variable-length package containing a list of Device Data Descriptor structures each consisting of a UUID (see *Universally Unique Identifiers (UUIDs)*) and a package (Data Structure). The UUID is all that is needed to define the Data Structure. The UUID itself *may* place a restriction based on `_HID` or the optional `_CID`, `_CLS`, `_HRV`, `_SUB` objects, or `_HID` and one of those optional objects. However, it also may not place such a restriction.

New UUIDs may be created by OEMs and IHVs or other interface or device governing bodies (e.g. the PCI SIG or the UEFI Forum), as long as the UUID is different from other published UUIDs.

The list of well-known UUIDs allocated for `_DSD` and the definition of data formats associated with them is available in an auxiliary document hosted on the UEFI Forum: <http://www.uefi.org/acpi>.

Arguments:

None

Return Value:

A variable-length Package containing a list of Device Data Descriptor structures as described below.

Return Value Information:

```

Package ()
{
    Device Data Descriptor 0
    ...
    Device Data Descriptor n
}

```

Each Device Data Descriptor structure consists of two elements, as follows:

```

UUID           // Buffer (16 bytes)
Data Structure // Package (depending on UUID)

```

UUID uniquely determines the format of Data Structure.

Data Structure is a set of device specific data items the format of which is uniquely determined by the *UUID* and the meaning of which is uniquely determined by the *UUID* possibly in combination with a PNP or ACPI device ID.

Multiple Device Data Descriptor structures with the same *UUID* are not permitted.

`_DSD` must return the same data each time it is evaluated. Firmware should not expect it to be evaluated every time (in case it is implemented as a method).

Examples:

Note: The UUID used in the following examples is assumed to define the data format for Data Structure as a list of packages of length 2 (Properties) whose first element (Key) must be a String and the second element is a Value associated with that key. The set of valid Keys and the format and interpretation of the Values associated with them is then dependent on the PNP or ACPI device ID of the device.

```
Device (MDEV) {
  Name (_HID, "PNP####")

  Name (_DSD, Package () {
    ToUUID("daffd814-6eba-4d8c-8a91-bc9bbf4aa301"),
    Package () {
      Package (2) {...}, // Property 1
      ...
      Package (2) {...} // Property n
    }
  })
}

//
// PWM controller with two pins that can be driven and a device using
// those pins with the periods of 5000000 and 4500000 nanoseconds,
// respectively.
//
Device (\_SB.PCI0.PWM) {
  Name (_HID, "PNP####")

  Name (_DSD, Package () {
    ToUUID("daffd814-6eba-4d8c-8a91-bc9bbf4aa301"),
    Package () {
      Package (2) {"#pwm-cells", 2}
    }
  })
}

Device (\_SB.PCI0.BL) {
  Name (_HID, "ACPI####")

  Name (_DSD, Package () {
    ToUUID("daffd814-6eba-4d8c-8a91-bc9bbf4aa301"),
    Package () {
      Package (2) {
        "pwms",
        Package () {
          \_SB.PCI0.PWM, 0, 5000000,
          \_SB.PCI0.PWM, 1, 4500000
        }
      }
    }
  })
}

//
// SPI controller using a fixed frequency clock represented by the CLK0
```

(continues on next page)

(continued from previous page)

```

// device object.
//
Device (\_SB_.PCI0) {
    Device (CLK0) {
        Name (_HID, "PNP####")

        Name (_DSD, Package () {
            ToUUID("daffd814-6eba-4d8c-8a91-bc9bbf4aa301"),
            Package () {
                Package (2) {"#clock-cells", 0},
                Package (2) {"clock-frequency", 120000000}
            }
        })
    }

    Device (SPI0) {
        Name (_HID, "PNP####")

        Name (_DSD, Package () {
            ToUUID("daffd814-6eba-4d8c-8a91-bc9bbf4aa301"),
            Package () {
                Package (2) {"clocks", Package () {1, ^CLK0}}
            }
        })

        ...
    }
}

```

6.2.6 _FIX (Fixed Register Resource Provider)

This optional object is used to provide a correlation between the fixed-hardware register blocks defined in the FADT and the devices in the ACPI namespace that implement these fixed-hardware registers. This object evaluates to a package of Plug and Play-compatible IDs (32-bit compressed EISA type IDs) that correlate to the fixed-hardware register blocks defined in the FADT. The device under which _FIX appears plays a role in the implementation of the fixed-hardware (for example, implements the hardware or decodes the hardware's address). _FIX conveys to OSPM whether a given device can be disabled, powered off, or should be treated specially by conveying its role in the implementation of the ACPI fixed-hardware register interfaces. This object takes no arguments.

The _CRS object describes a device's resources. That _CRS object may contain a superset of the resources in the FADT, as the device may actually decode resources beyond what the FADT requires. Furthermore, in a machine that performs translation of resources within I/O bridges, the processor-relative resources in the FADT may not be the same as the bus-relative resources in the _CRS.

Arguments:

None

Return Value:

A variable-length **Package** containing a list of **Integers**, each containing a PNP ID

Each of fields in the FADT has its own corresponding Plug and Play ID, as shown below:

```

PNP0C20 - SMI_CMD
PNP0C21 - PM1a_EVT_BLK / X\_ PM1a_EVT_BLK

```

(continues on next page)

(continued from previous page)

```

PNP0C22 - PM1b_EVT_BLK / X_PM1b_EVT_BLK
PNP0C23 - PM1a_CNT_BLK / X_PM1a_CNT_BLK
PNP0C24 - PM1b_CNT_BLK / X\_ PM1b_CNT_BLK
PNP0C25 - PM2_CNT_BLK / X\_ PM2_CNT_BLK
PNP0C26 - PM_TMR_BLK / X\_ PM_TMR_BLK
PNP0C27 - GPE0_BLK / X_GPE0_BLK
PNP0C28 - GPE1_BLK / X\_ GPE1_BLK
PNP0B00 - FIXED_RTC
PNP0B01 - FIXED_RTC
PNP0B02 - FIXED_RTC

```

Example ASL for _FIX usage:

```

Scope (\_SB) {
    Device (PCI0) {
        Name (_HID, EISAID("PNP0A03")) // Root PCI Bus
        Method (_CRS, 0) { // Need \_HID for root device
            // Need current resources for root device
            // Return current resources for root bridge 0
        }
        Name (_PRT, Package () { // Need PCI IRQ routing for PCI bridge
            // Package with PCI IRQ routing table
        })
        Name (_FIX, Package (1) { // PM2 control ID
            EISAID ("PNP0C25") }
        )
        Device (PX40) { // ISA
            Name (_ADR, 0x00070000)
            Name (_FIX, Package (1) { // SMI command port
                EISAID ("PNP0C20") }
            )
            Device (NS17) { // NS17 (Nat. Semi 317, an ACPI part)
                Name (_HID, EISAID ("PNP0C02"))
                Name (_FIX, Package (3) {
                    EISAID ("PNP0C22"), // PM1b event ID
                    EISAID ("PNP0C24"), // PM1b control ID
                    EISAID ("PNP0C28") } // GPE1 ID
                )
            }
        } // end PX40
        Device (PX43) { // PM Control
            Name (_ADR, 0x00070003)
            Name (_FIX, Package (4) {
                EISAID ("PNP0C21"), // PM1a event ID
                EISAID ("PNP0C23"), // PM1a control ID
                EISAID ("PNP0C26"), // PM Timer ID
                EISAID ("PNP0C27") } // GPE0 ID
            )
        } // end PX43
    } // end PCI0
} // end scope SB

```

6.2.7 _GSB (Global System Interrupt Base)

_GSB is an optional object that evaluates to an integer that corresponds to the Global System Interrupt Base for the corresponding I/O APIC device. The I/O APIC device may either be bus enumerated (e.g. as a PCI device) or enumerated in the namespace as described in *I/O APIC Device*. Any I/O APIC device that either supports hot-plug or is not described in the MADT must contain a _GSB object.

If the I/O APIC device also contains a _MAT object, OSPM evaluates the _GSB object first before evaluating the _MAT object. By providing the Global System Interrupt Base of the I/O APIC, this object enables OSPM to process only the _MAT entries that correspond to the I/O APIC device. See *_MAT (Multiple APIC Table Entry)*. Since _MAT is allowed to potentially return all the MADT entries for the entire platform, _GSB is needed in the I/O APIC device scope to enable OSPM to identify the entries that correspond to that device.

If an I/O APIC device is activated by a device-specific driver, the physical address used to access the I/O APIC will be exposed by the driver and cannot be determined from the _MAT object. In this case, OSPM cannot use the _MAT object to determine the Global System Interrupt Base corresponding to the I/O APIC device and hence requires the _GSB object.

The Global System Interrupt Base is a 64-bit value representing the corresponding I/OAPIC device as defined in *Global System Interrupts*.

Arguments:

None **Return Value:** An Integer containing the interrupt base

Example ASL for _GSB usage for a non-PCI based I/O APIC Device:

```
Scope (\_SB) {
    ...
    Device(APIC) { // I/O APIC Device
        Name(_HID, "ACPI0009") // ACPI ID for I/O APIC
        Name(_CRS, ResourceTemplate()
            { ...}) // only one resource pointing to I/O APIC register base
        Method(_GSB){
            Return (0x10) // Global System Interrupt Base for I/O APIC starts at 16
        }
    } // end APIC
} // end scope SB
```

Example ASL for _GSB usage for a PCI-based I/O APIC Device:

```
Scope (\_SB) {
    Device(PCI0) // Host bridge
        Name(_HID, EISAID("PNP0A03")) // Need \_HID for root device
    Device(PCI1) { // I/O APIC PCI Device
        Name(_ADR, 0x00070000)
        Method(_GSB){
            Return (0x18) // Global System Interrupt Base for I/O APIC_
↪starts at 24
        }
    } // end PCI1
} // end PCI0
} // end scope SB
```

6.2.8 _HPP (Hot Plug Parameters)

This optional object evaluates to a package containing the cache-line size, latency timer, SERR enable, and PERR enable values to be used when configuring a PCI device inserted into a hot-plug slot or for performing configuration of a PCI devices not configured by the platform boot firmware at system boot. The object is placed under a PCI bus where this behavior is desired, such as a bus with hot-plug slots. _HPP provided settings apply to all child buses, until another _HPP object is encountered.

Arguments:

None

Return Value:

A **Package** containing the **Integer** hot-plug parameters

Example:

```
Method (_HPP, 0) {
    Return (Package(4){
        0x08, // CacheLineSize in DWORDS
        0x40, // LatencyTimer in PCI clocks
        0x01, // Enable SERR (Boolean)
        0x00 // Enable PERR (Boolean)
    })
}
```

Table 6.7: HPP Package Contents

Field	Object Type	Definition
Cache-line size	Integer	Cache-line size reported in number of DWORDs.
Latency timer	Integer	Latency timer value reported in number of PCI clock cycles.
Enable SERR	Integer	When set to 1, indicates that action must be performed to enable SERR in the command register.
Enable PERR	Integer	When set to 1, indicates that action must be performed to enable PERR in the command register.

Example: Using _HPP

```
Scope (\_SB) {
    Device (PCI0) { // Root PCI Bus
        Name (_HID, EISAID("PNP0A03")) // \_HID for root device
        Method (_CRS, 0) { // Need current resources for root dev
            // Return current resources for root bridge 0
        }
        Name (_PRT, Package() { // Need PCI IRQ routing for PCI bridge
            // Package with PCI IRQ routing table information
        })
        Device (P2P1) { // First PCI-to-PCI bridge (No Hot Plug slots)
            Name (_ADR, 0x000C0000) // Device#Ch, Func#0 on bus PCI0
            Name (_PRT, Package() { // Need PCI IRQ routing for PCI bridge
                // Package with PCI IRQ routing table information
            })
        } // end P2P1
        Device (P2P2) { // Second PCI-to-PCI bridge (Bus contains Hot plug_
↪ slots)
```

(continues on next page)

(continued from previous page)

```

Name(_ADR, 0x000E0000) // Device#Eh, Func#0 on bus PCI0
Name(_PRT, Package()) { // Need PCI IRQ routing for PCI bridge
                        // Package with PCI IRQ routing table information
})
Name(_HPP, Package()) {0x08, 0x40, 0x01, 0x00}
// Device definitions for Slot 1- HOT PLUG SLOT
Device (S1F0) { // Slot 1, Func#0 on bus P2P2
    Name(_ADR, 0x00020000)
    Method(_EJ0, 1) { // Remove all power to device}
}
Device (S1F1) { // Slot 1, Func#1 on bus P2P2
    Name(_ADR, 0x00020001)
    Method(_EJ0, 1) { // Remove all power to device}
}
Device (S1F2) { // Slot 1, Func#2 on bus P2P2
    Name(_ADR, 0x00020002)
    Method(_EJ0, 1) { // Remove all power to device}
}
Device (S1F3) { // Slot 1, Func#3 on bus P2P2
    Name(_ADR, 0x00020003)
    Method(_EJ0, 1) { // Remove all power to device}
}
Device (S1F4) { // Slot 1, Func#4 on bus P2P2
    Name(_ADR, 0x00020004)
    Method(_EJ0, 1) { // Remove all power to device}
}
Device (S1F5) { // Slot 1, Func#5 on bus P2P2
    Name(_ADR, 0x00020005)
    Method(_EJ0, 1) { // Remove all power to device}
}
Device (S1F6) { // Slot 1, Func#6 on bus P2P2
    Name(_ADR, 0x00020006)
    Method(_EJ0, 1) { // Remove all power to device}
}
Device (S1F7) { // Slot 1, Func#7 on bus P2P2
    Name(_ADR, 0x00020007)
    Method(_EJ0, 1) { // Remove all power to device}
}
// Device definitions for Slot 2- HOT PLUG SLOT
Device (S2F0) { // Slot 2, Func#0 on bus P2P2
    Name(_ADR, 0x00030000)
    Method(_EJ0, 1) { // Remove all power to device}
}
Device (S2F1) { // Slot 2, Func#1 on bus P2P2
    Name(_ADR, 0x00030001)
    Method(_EJ0, 1) { // Remove all power to device}
}
Device (S2F2) { // Slot 2, Func#2 on bus P2P2
    Name(_ADR, 0x00030002)
    Method(_EJ0, 1) { // Remove all power to device}
}
Device (S2F3) { // Slot 2, Func#3 on bus P2P2
    Name(_ADR, 0x00030003)
    Method(_EJ0, 1) { // Remove all power to device}
}
Device (S2F4) { // Slot 2, Func#4 on bus P2P2
    Name(_ADR, 0x00030004)

```

(continues on next page)

(continued from previous page)

```

        Method(_EJ0, 1) { // Remove all power to device}
    }
    Device (S2F5) { // Slot 2, Func#5 on bus P2P2
        Name(_ADR, 0x00030005)
        Method(_EJ0, 1) { // Remove all power to device}
    }
    Device (S2F6) { // Slot 2, Func#6 on bus P2P2
        Name(_ADR, 0x00030006)
        Method(_EJ0, 1) { // Remove all power to device}
    }
    Device (S2F7) { // Slot 2, Func#7 on bus P2P2
        Name(_ADR, 0x00030007)
        Method(_EJ0, 1) { // Remove all power to device}
    }
} // end P2P2
} // end PCI0
} // end Scope (\_SB)

```

OSPM will configure a PCI device on a card hot-plugged into slot 1 or slot 2, with a cache line size of 32 (Notice this field is in DWORDs), latency timer of 64, enable SERR, but leave PERR alone.

6.2.9 _HPX (Hot Plug Parameter Extensions)

This optional object provides platform-specific information to the OSPM PCI driver component responsible for configuring PCI, PCI-X, or PCI Express Functions. The information conveyed applies to the entire hierarchy downward from the scope containing the _HPX object. If another _HPX object is encountered downstream, the settings conveyed by the lower-level object apply to that scope downward.

OSPM uses the information returned by _HPX to determine how to configure PCI Functions that are hot-plugged into the system, to configure Functions not configured by the platform firmware during initial system boot, and to configure Functions any time they lose configuration space settings (e.g. OSPM issues a Secondary Bus Reset/Function Level Reset or Downstream Port Containment is triggered). The _HPX object is placed within the scope of a PCI-compatible bus where this behavior is desired, such as a bus with hot-plug slots. It returns a single package that contains one or more sub-packages, each containing a single Setting Record. Each such Setting Record contains a Setting Type (INTEGER), a Revision number (INTEGER) and type/revision specific contents.

The format of data returned by the _HPX object is extensible. The Setting Type and Revision number determine the format of the Setting Record. OSPM ignores Setting Records of types that it does not understand. A Setting Record with higher Revision number supersedes that with lower revision number, however, the _HPX method can return both together, OSPM shall use the one with highest revision number that it understands. Type 3 records may have multiple records with the same revision or different revision (refer to the Revision field in *PCI Express Descriptor Setting Record Content*). Out of all the Type 3 records, the OSPM shall determine the highest revision number that it understands and use all Type 3 records with that revision.

_HPX may return multiple types or Record Settings (each setting in a single sub-package.) OSPM is responsible for detecting the type of Function and for applying the appropriate settings. OSPM is also responsible for detecting the device / port type of the PCI Express Function and applying the appropriate settings provided. For example, the Secondary Uncorrectable Error Severity and Secondary Uncorrectable Error Mask settings of Type 2 record are only applicable to PCI Express to PCI-X/PCI Bridge whose device / port type is 1000b. Similarly, AER settings are only applicable to hot plug PCI Express devices that support the optional AER capability.

Arguments:

None

Return Value:

A variable-length **Package** containing a list of **Packages**, each containing a single PCI, PCI-X, PCI Express, or PCI Express Descriptor Record Setting as described below

The `_HPX` object supersedes the `_HPP` object. If the `_HPP` and `_HPX` objects exist within a device's scope, OSPM will only evaluate the `_HPX` object.

Note: OSPM may override the settings provided by the `_HPX` object's Type2 record (PCI Express Settings) or Type3 record (PCI Express Descriptor Settings) when OSPM has assumed native control of the corresponding feature. For example, if OSPM has assumed ownership of AER (via `_OSC`), OSPM may override AER related settings returned by `_HPX`.

Note: Since error status registers do not drive error signaling, OSPM is not required to clear error status registers as part of `_HPX` handling.

Note: There are other mechanisms besides `_HPX` that provide platform-specific information to the OSPM PCI driver component responsible for configuring PCI, PCI-X, or PCI Express Functions (e.g., `_DSM` Definitions for Latency Tolerance Reporting as defined in the PCI Firmware Specification). System firmware should only provide platform-specific information via one of these mechanisms for any given register or feature (i.e., if Latency Tolerance Reporting information is provided via `_DSM` Definitions for Latency Tolerance Reporting then no information related to Latency Tolerance Reporting should be provided by `_HPX` and vice versa). Failure to do so will result in undefined behavior from the OSPM.

6.2.9.1 PCI Setting Record (Type 0)

The PCI setting record contains the setting type 0, the current revision 1 and the type/revision specific content: cache-line size, latency timer, SERR enable, and PERR enable values.

Table 6.8: PCI Setting Record Content

Field	Object Type	Definition
Header		
- Type	Integer	0x00: Type 0 (PCI) setting record.
- Revision	Integer	0x01: Revision 1, defining the set of fields below.
Cache-line size	Integer	Cache-line size reported in number of DWORDs.
Latency timer	Integer	Latency timer value reported in number of PCI clock cycles.
Enable SERR	Integer	When set to 1, indicates that action must be performed to enable SERR in the command register.
Enable PERR	Integer	When set to 1, indicates that action must be performed to enable PERR in the command register.

If the hot plug device includes bridge(s) in the hierarchy, the above settings apply to the primary side (command register) of the hot plugged bridge(s). The settings for the secondary side of the bridge(s) (Bridge Control Register) are assumed to be provided by the bridge driver.

The Type 0 record is applicable to hot plugged PCI, PCI-X and PCI Express devices. OSPM will ignore settings provided in the Type0 record that are not applicable (for example, Cache-line size and Latency Timer are not applicable to PCI Express).

6.2.9.2 PCI-X Setting Record (Type 1)

The PCI-X setting record contains the setting type 1, the current revision 1 and the type/revision specific content: the maximum memory read byte count setting, the average maximum outstanding split transactions setting and the total maximum outstanding split transactions to be used when configuring PCI-X command registers for PCI-X buses and/or devices.

Table 6.9: PCI-X Setting Record Content

Field	Object Type	Definition
Header		
- Type	Integer	0x01: Type 1 (PCI-X) setting record.
- Revision	Integer	0x01: Revision 1, defining the set of fields below.
Maximum memory read byte count	Integer	Maximum memory read byte count reported: Value 0: Maximum byte count 512 Value 1: Maximum byte count 1024 Value 2: Maximum byte count 2048 Value 3: Maximum byte count 4096
Average maximum outstanding split transactions	Integer	The following values are defined: Value 0: Maximum outstanding split transaction 1 Value 1: Maximum outstanding split transaction 2 Value 2: Maximum outstanding split transaction 3 Value 3: Maximum outstanding split transaction 4 Value 4: Maximum outstanding split transaction 8 Value 5: Maximum outstanding split transaction 12 Value 6: Maximum outstanding split transaction 16 Value 7: Maximum outstanding split transaction 32
Total maximum outstanding split transactions	Integer	See the definition for the average maximum outstanding split transactions.

For simplicity, OSPM could use the Average Maximum Outstanding Split Transactions value as the Maximum Outstanding Split Transactions register value in the PCI-X command register for each PCI-X device. Another alternative is to use a more sophisticated policy and the Total Maximum Outstanding Split Transactions Value to gain even more performance. In this case, the OS would examine each PCI-X device that is directly attached to the host bridge, determine the number of outstanding split transactions supported by each device, and configure each device accordingly. The goal is to ensure that the aggregate number of concurrent outstanding split transactions does not exceed the Total Maximum Outstanding Split Transactions Value: an integer denoting the number of concurrent outstanding split transactions the host bridge can support (the minimum value is 1).

This object does not address providing additional information that would be used to configure registers in bridge devices, whether architecturally-defined or specification-defined registers or device specific registers. It is expected that a driver for a bridge would be the proper implementation mechanism to address both of those issues. However, such a bridge driver should have access to the data returned by the `_HPX` object for use in optimizing its decisions on how to configure the bridge. Configuration of a bridge is dependent on both system specific information such as that provided by the `_HPX` object, as well as bridge specific information.

6.2.9.3 PCI Express Setting Record (Type 2)

The PCI Express setting record contains the setting type 2, the current revision 1 and the type/revision specific content (the control registers as listed in the table below) to be used when configuring registers in the Advanced Error Reporting Extended Capability Structure or PCI Express Capability Structure for the PCI Express devices.

The Type 2 Setting Record allows a PCI Express-aware OS that supports native hot plug to configure the specified registers of the hot plugged PCI Express device. A PCI Express-aware OS that has assumed ownership of native hot plug (via `_OSC`) but does not support or does not have ownership of the AER register set must use the data values returned by the `_HPX` object's Type 2 record to program the AER registers of a hot-added PCI Express device.

However, since the Type 2 record also includes register bits that have functions other than AER, OSPM must ignore values contained within this setting record that are not applicable.

To support PCIe RsvdP semantics for reserved bits, two values for each register are provided: an “AND mask” and an “OR mask”. Each bit understood by firmware to be RsvdP shall be set to 1 in the “AND mask” and 0 in the “OR mask”. Each bit that firmware intends to be configured as 0 shall be set to 0 in both the “AND mask” and the “OR mask”. Each bit that firmware intends to be configured a 1 shall be set to 1 in both the “AND mask” and the “OR mask”.

When configuring a given register, OSPM uses the following algorithm:

1. Read the register’s current value, which contains the register’s default value.
2. Perform a bit-wise AND operation with the “AND mask” from the table below.
3. Perform a bit-wise OR operation with the “OR mask” from the table below.
4. Override the computed settings for any bits if deemed necessary. For example, if OSPM is aware of an architected meaning for a bit that firmware considers to be RsvdP, OSPM may choose to override the computed setting for that bit. Note that firmware sets the “AND value” to 1 and the “OR value” to 0 for each bit that it considers to be RsvdP.
5. Write the end result value back to the register.

Note that the size of each field in the following table matches the size of the corresponding PCI Express register.

Table 6.10: PCI Express Setting Record Content

Field	Object Type	Definition
Header		
- Type	Integer	0x02: Type 2 (PCI Express) setting record.
- Revision	Integer	0x01: Revision 1, defining the set of fields below.
Uncorrectable Error Mask Register AND Mask	Integer	Bits [31:0] contain the “AND mask” to be used in the OSPM algorithm described above.
Uncorrectable Error Mask Register OR Mask	Integer	Bits [31:0] contain the “OR mask” to be used in the OSPM algorithm described above.
Uncorrectable Error Severity Register AND Mask	Integer	Bits [31:0] contain the “AND mask” to be used in the OSPM algorithm described above.
Uncorrectable Error Severity Register OR Mask	Integer	Bits [31:0] contain the “OR mask” to be used in the OSPM algorithm described above.
Correctable Error Mask Register AND Mask	Integer	Bits [31:0] contain the “AND mask” to be used in the OSPM algorithm described above.
Correctable Error Mask Register OR Mask	Integer	Bits [31:0] contain the “OR mask” to be used in the OSPM algorithm described above.
Advanced Error Capabilities and Control Register AND Mask	Integer	Bits [31:0] contain the “AND mask” to be used in the OSPM algorithm described above.
Advanced Error Capabilities and Control Register OR Mask	Integer	Bits [31:0] contain the “OR mask” to be used in the OSPM algorithm described above.
Device Control Register AND Mask	Integer	Bits [15 :0] contain the “AND mask” to be used in the OSPM algorithm described above.
Device Control Register OR Mask	Integer	Bits [15:0] contain the “OR mask” to be used in the OSPM algorithm described above.
Link Control Register AND Mask	Integer	Bits [15 :0] contain the “AND mask” to be used in the OSPM algorithm described above.
Link Control Register OR Mask	Integer	Bits [15 :0] contain the “OR mask” to be used in the OSPM algorithm described above.

continues on next page

Table 6.10 – continued from previous page

Secondary Uncorrectable Error Severity Register AND Mask	Integer	Bits [31 :0] contain the “AND mask” to be used in the OSPM algorithm described above
Secondary Uncorrectable Error Severity Register OR Mask	Integer	Bits [31 :0] contain the “OR mask” to be used in the OSPM algorithm described above
Secondary Uncorrectable Error Mask Register AND Mask	Integer	Bits [31 :0] contain the “AND mask” to be used in the OSPM algorithm described above
Secondary Uncorrectable Error Mask Register OR Mask	Integer	Bits [31 :0] contain the “OR mask” to be used in the OSPM algorithm described above

6.2.9.4 PCI Express Descriptor Setting Record (Type 3)

The PCI Express Descriptor setting record contains the setting type 3, the current revision 1 and the type/revision specific content (the control registers as listed in the tables below) to be used when configuring registers in PCI Express Functions. There may be multiple PCI Express Descriptor setting records in a single `_HPX` object with the same or different revision. Each PCI Express Descriptor setting record shall contain at least one, and may contain more than one, PCI Express Register Descriptors as defined in *PCI Express Register Descriptor*.

The Type 3 Setting Record allows a PCI Express-aware OS to configure the indicated registers of the PCI Express Function. A PCI Express-aware OS that does not support or does not have ownership of a register in this record must use the data values returned by the `_HPX` object’s Type 3 record to program that register of a PCI Express Function that has lost its configuration space settings (e.g. a hot-added device, a device not configured by the platform firmware during initial system boot, a Device/Function that was reset via Secondary Bus Reset/Function Level Reset, Downstream Port Containment was triggered, etc.).

To support PCIe RsvdP semantics for reserved bits, two values for each register indicated by Write Register Offset are provided: a Write AND Mask and a Write OR Mask. Each bit understood by firmware to be RsvdP shall be set to 1 in the Write AND Mask and 0 in the Write OR Mask. Each bit that firmware intends to be configured as 0 shall be set to 0 in both the Write AND Mask and the Write OR Mask. Each bit that firmware intends to be configured a 1 shall be set to 1 in both the Write AND Mask and the Write OR Mask.

OSPM evaluates each PCI Express Register Descriptor in order starting with the first PCI Express Register Descriptor and continuing through the Nth PCI Express Register Descriptor as shown in *PCI Express Descriptor Setting Record Content* for each PCI Express Function that has lost its configuration space settings (e.g. a hot-added device, a device not configured by the platform firmware during initial system boot, a Device/Function that was reset via Secondary Bus Reset/Function Level Reset, Downstream Port Containment was triggered, etc.) in the scope of the `_HPX` method using the following algorithm:

1. Verify the PCI Express Register Descriptor applies to the PCI Express Function.
 - a. Read the PCI Express Function’s Device Type/Port from its PCI Express Capabilities Register.
 - b. Read the bit corresponding to the PCI Express Function’s Device Port/Type in the Device/Port Type from *PCI Express Register Descriptor* below.

If set to 0b, then the PCI Express Register Descriptor does not apply to the PCI Express Function and OSPM moves to the next Function in the scope of the `_HPX` method or the next PCI Express Register Descriptor if there are no more Functions.

If set to 1b, then continue to the next step.
 - c. Determine if the PCI Express Function is a non-SR-IOV Function, an SR-IOV Physical Function, or an SR-IOV Virtual Function.
 - d. Read the bit corresponding to the PCI Express Function’s type in the Function Type from *PCI Express Register Descriptor* below.

If set to 0b, then the PCI Express Register Descriptor does not apply to the PCI Express Function and OSPM moves to the next Function in the scope of the `_HPX` method or to the next PCI Express Register Descriptor if there are no more Functions.

If set to 1b, then the PCI Express Register Descriptor applies to the PCI Express Function and OSPM continues to the next step.

2. Read the Configuration Space Location from *PCI Express Register Descriptor* below.

- a. If Configuration Space Location is 0, then the Match Register Offset and Write Register Offset field's byte offset is relative to offset 0 of the Function's configuration space.
- b. If Configuration Space Location is 1, then the Match Register Offset and Write Register Offset field's byte offset is relative to the starting offset of the Capability Structure indicated by PCIe Capability ID.

If the Capability ID is 01h (PCI Power Management Capability Structure) or 10h (PCI Express Capability Structure) then OSPM shall check the Capability Version of the Function's Capability Structure against the PCIe Capability ID field. In the event that there are more than one PCI Express Register Descriptors for a given PCIe Capability ID with different PCIe Capability Versions, OSPM shall use the PCI Express Register Descriptors with the highest PCIe Capability Version supported by the Function.

There may be more than one instance of a Capability Structure that matches the indicated PCIe Capability ID. Continue to step 3 for each such instance. If no Capability Structures indicated by PCIe Capability ID are found, then start back at step 1 above for the next Function in the scope of the `_HPX` method or the next PCI Express Register Descriptor if there are no more Functions.

- c. If Configuration Space Location is 2, then the Match Register Offset and Write Register Offset field's byte offset is relative to the starting offset of the Extended Capability Structure indicated by PCIe Capability ID and PCIe Capability Version.

In the event that there are more than one PCI Express Register Descriptors for a given PCIe Capability ID with different PCIe Capability Versions, OSPM shall use the PCI Express Register Descriptors with the highest PCIe Capability Version supported by the Function.

There may be more than one instance of an Extended Capability Structure that matches the indicated PCIe Capability ID and PCIe Capability Version. Continue to step 3 for each such instance. If no Extended Capability Structures indicated by PCIe Capability ID and PCIe Capability Version are found, then start back at step 1 above for the next Function in the scope of the `_HPX` method or the next PCI Express Register Descriptor if there are no more Functions.

- d. If Configuration Space Location is 3, then the Match Register Offset and Write Register Offset field's byte offset is relative to the starting offset of the Extended Capability Structure indicated by PCIe Capability ID, PCIe Capability Version, PCIe Vendor ID, VSEC ID, and VSEC Rev.

In the event that there are more than one PCI Express Register Descriptors for a given PCIe Capability ID with different PCIe Capability Versions, OSPM shall use the PCI Express Register Descriptors with the highest PCIe Capability Version supported by the Function.

Once the PCI Express Register Descriptors that match the PCIe Capability ID with the highest PCIe Capability Version supported by the Function are found, the OSPM shall use PCI Express Register Descriptors among those with the highest VSEC Rev supported by the Function.

There may be more than one instance of an Extended Capability Structure that matches the indicated PCIe Capability ID, PCIe Capability Version, PCIe Vendor ID, VSEC ID, and VSEC Rev. Continue to step 3 for each such instance. If no Extended Capability Structures indicated by PCIe Capability ID, PCIe Capability Version, PCIe Vendor ID, VSEC ID, and VSEC Rev are found, then start back at step 1 above for the next Function in the scope of the `_HPX` method or the next PCI Express Register Descriptor if there are no more Functions.

- e. If Configuration Space Location is 4, then the Match Register Offset and Write Register Offset field's byte offset is relative to the starting offset of the Extended Capability Structure indicated by PCIe Capability

ID, PCIe Capability Version, PCIe Vendor ID, DVSEC ID, and DVSEC Rev.

In the event that there are more than one PCI Express Register Descriptors for a given PCIe Capability ID with different PCIe Capability Versions, OSPM shall use the PCI Express Register Descriptors with the highest PCIe Capability Version supported by the Function.

Once the PCI Express Register Descriptors that match the PCIe Capability ID with the highest PCIe Capability Version supported by the Function are found, the OSPM shall use PCI Express Register Descriptors among those with the highest DVSEC Rev supported by the Function.

There may be more than one instance of an Extended Capability Structure that matches the indicated PCIe Capability ID, PCIe Capability Version, PCIe Vendor ID, DVSEC ID, and DVSEC Rev. Continue to step 3 for each such instance. If no Extended Capability Structures indicated by PCIe Capability ID, PCIe Capability Version, PCIe Vendor ID, DVSEC ID, and DVSEC Rev are found, then start back at step 1 above for the next Function in the scope of the _HPX method or the next PCI Express Register Descriptor if there are no more Functions.

3. Check the Match Register to see if the Write Register should be updated.
 - a. Read the current value from the register indicated by the Match Register Offset.
 - b. Perform a bit-wise AND operation on the result of step 3a with the Match AND Mask.
 - c. Compare the result of step 3b with the Match Value. If they are equal then continue to step 4, else start back at step 1 above for the next Function
 - d. In the scope of the _HPX method or the next PCI Express Register Descriptor if there are no more Functions.
4. Update the Write Register.
 - a. Read the current value from the register indicated by the Write Register Offset.
 - b. Perform a bit-wise AND operation on the result of step 4a with the Write AND Mask.
 - c. Perform a bit-wise OR operation on the result of step 4b with the Write OR Mask.
 - d. Override the computed settings from step 4c for any bits if deemed necessary. For example, if OSPM is aware of an architected meaning for a bit that firmware considers to be RsvdP, OSPM may choose to override the computed setting for that bit. Note that firmware sets the Write AND Mask to 1 and the Write OR Mask to 0 for each bit that it considers to be RsvdP.
 - e. Write the result of step 4d back to the register indicated by the Write Register Offset.

Table 6.11: PCI Express Descriptor Setting Record Content

Field	Object Type	Definition
Header		
- Type	Integer	0x03: Type 3 (PCI Express Descriptor) setting record.
- Revision	Integer	0x01: Revision 1, defining the set of fields below.
PCI Express Register Descriptor Count	Integer	Number of Register Descriptors in this setting record.
First PCI Express Register Descriptor	PCI Express Register Descriptor	The first PCI Express Register Descriptor as described in Table 6.12
Second PCI Express Register Descriptor	PCI Express Register Descriptor	The second PCI Express Register Descriptor as described in Table 6.12
...
Nth PCI Express Register Descriptor	PCI Express Register Descriptor	The Nth PCI Express Register Descriptor as described in Table 6.12

Table 6.12: PCI Express Register Descriptor

Field	Object Type	Definition
Device/Port Type	Integer	<p>This field is a bitmask of Device/Port Types to which the PCI Express Register Descriptor applies. A bit is set to 1 to indicate the PCI Express Register Descriptor applies to the corresponding Device/Port Type and is set to 0 to indicate it does not apply to the corresponding Device/Port Type. At least one bit shall be set. More than one bit may be set.</p> <p>Bit [0]: PCI Express Endpoint Bit [1]: Legacy PCI Express Endpoint Bit [2]: RCiEP Bit [3]: Root Complex Event Collector Bit [3]: Root Complex Event Collector Bit [4]: Root Port of PCI Express Root Complex Bit [5]: Upstream Port of PCI Express Switch Bit [6]: Downstream Port of PCI Express Switch Bit [7]: PCI Express to PCI/PCI-X Bridge Bit [8]: PCI/PCI-X to PCI Express Bridge All other bits are reserved.</p>
Function Type	Integer	<p>This field is a bitmask of Function Types to which the PCI Express Register Descriptor applies. A bit is set to 1 to indicate the PCI Express Register Descriptor applies to the corresponding Function Type and is set to 0 to indicate it does not apply to the corresponding Function Type. At least one bit shall be set. More than one bit may be set.</p> <p>Bit [0]: Non-SR-IOV Function Bit [1]: SR-IOV Physical Function Bit [2]: SR-IOV Virtual Function All other bits are reserved</p>

continues on next page

Table 6.12 – continued from previous page

<p>Configuration Space Location</p>	<p>Integer</p>	<p>A value of 0 indicates the Match Register Offset and Write Register Offset fields are relative to offset 0 of the Function’s configuration space.</p> <p>A value of 1 indicates the Match Register Offset and Write Register Offset fields are located in a Capability Structure within the first 256 bytes of PCIe configuration space and are relative to offset 0 of the Capability Structure.</p> <p>A value of 2 indicates the Match Register Offset and Write Register Offset fields are located in an Extended Capability Structure beyond the first 256 bytes of PCI configuration space and are relative to offset 0 of the Extended Capability Structure.</p> <p>A value of 3 indicates the Match Register Offset and Write Register fields are located in a PCI Express Vendor-Specific Extended Capability and are relative to offset 0 of the Vendor-Specific Extended Capability.</p> <p>A value of 4 indicates the Match Register Offset and Write Register Offset fields are located in a PCI Express Designated Vendor-Specific Extended Capability and are relative to offset 0 of the Designated Vendor-Specific Extended Capability.</p> <p>All other values are reserved.</p>
<p>PCIe Capability ID</p>	<p>Integer</p>	<p>PCIe Capability ID indicates the capability ID to which the PCI Express Register Descriptor applies: Capability Structure (if Configuration Space Location is 1) or Extended Capability Structure (if Configuration Space Location is 2).</p> <p>This field only applies if Configuration Space Location is 1 (Capability Structure), 2 (Extended Capability Structure), 3 (Vendor-Specific Extended Capability), or 4 (Designated Vendor-Specific Extended Capability).</p>

continues on next page

Table 6.12 – continued from previous page

PCIe Capability Version	Integer	<p>This field contains information about the Capability Version/Extended Capability Version and applies in the following conditions:</p> <ul style="list-style-type: none"> - Configuration Space Location is 1 (Capability Structure) and Capability ID is 01h (PCI Power Management Capability Structure); or - Configuration Space Location is 1 (Capability Structure) and Capability ID is 10h (PCI Express Capability Structure); or - Configuration Space Location is 2 (Extended Capability Structure); or - Configuration Space Location is 3 (Vendor-Specific Extended Capability); or - Configuration Space Location is 4 (Designated Vendor-Specific Extended Capability). <p>Bit [4] indicates the applicability of the Capability Version/Extended Capability Version in bits [3:0]. Defined values are:</p> <ul style="list-style-type: none"> - 0b: The PCI Express Register Descriptor applies to Capability Structures/Extended Capability Structures with Capability Versions that are equal to the version in bits [3:0]. - 1b: The PCI Express Register Descriptor applies to Capability Structures/Extended Capability Structures with Capability Versions that are greater than or equal to the version in bits [3:0]. <p>Bits [3:0] indicate the Capability Version of the Capability Structures/Extended Capability Structure. Note that the version of the Capability Structure/Extended Capability Structure is always 4 bits except for the PCI Power Management Capability Structure whose Version field is only 3 bits. For the PCI Power Management Capability structure, this field shall contain the Version in bits [2:0] and bit [3] shall be 0b.</p> <p>All other bits are reserved.</p>
PCIe Vendor ID	Integer	<p>If Configuration Space Location is 3 (Vendor-Specific Extended Capability Structure), this field indicates the vendor in the Vendor ID register at offset 0 of the Function's configuration space to which the PCI Express Register Descriptor applies.</p> <p>If Configuration Space Location is 4 (Designated Vendor-Specific Extended Capability Structure), this field indicates the vendor in the DVSEC Vendor ID register at offset 4 in the Designated Vendor-Specific Extended Capability Structure to which the PCI Express Register Descriptor applies.</p> <p>This field only applies if Configuration Space Location is 3 (Vendor-Specific Extended Capability Structure) or 4 (Designated Vendor-Specific Extended Capability Structure).</p>

continues on next page

Table 6.12 – continued from previous page

VSEC/DVSEC ID	Integer	<p>If Configuration Space Location is 3 (Vendor-Specific Extended Capability Structure), this field indicates the vendor-defined ID number (VSEC ID) of the Vendor-Specific Extended Capability Structure to which the PCI Express Register Descriptor applies.</p> <p>If Configuration Space Location is 4 (Designated Vendor-Specific Extended Capability Structure), this field indicates the DVSEC ID of the Designated Vendor-Specific Extended Capability Structure to which the PCI Express Register Descriptor applies.</p> <p>This field only applies if Configuration Space Location is 3 (Vendor-Specific Extended Capability Structure) or 4 (Designated Vendor-Specific Extended Capability Structure).</p>
VSEC/DVSEC Rev	Integer	<p>This field contains information about the VSEC/DVSEC Rev and only applies if Configuration Space Location is 3 (Vendor-Specific Extended Capability Structure) or 4 (Designated Vendor-Specific Extended Capability Structure).</p> <p>Bit [4] indicates the applicability of the VSEC/DVSEC Rev in bits [3:0]. Defined values are:</p> <ul style="list-style-type: none"> - 0b: The PCI Express Register Descriptor applies to Vendor Specific Extended Capabilities/Designated Vendor-Specific Capabilities with VSEC/DVSEC Revs that are equal to the revision in bits [3:0]. - 1b: The PCI Express Register Descriptor applies to Vendor Specific Extended Capabilities/Designated Vendor-Specific Capabilities with VSEC/DVSEC Revs that are greater than or equal to the revision in bits [3:0]. <p>Bits [3:0] - If Configuration Space Location is 3 (Vendor-Specific Extended Capability Structure), this field indicates the VSEC Rev of the Vendor-Specific Extended Capability Structure. If Configuration Space Location is 4 (Designated Vendor-Specific Extended Capability Structure), this field indicates the DVSEC Revision of the Designated Vendor-Specific Extended Capability Structure.</p> <p>All other bits are reserved.</p>
Match Register Offset	Integer	Byte offset of the PCIe configuration space register that is checked before the write. This offset shall be dword aligned (i.e. bits [1:0] are 00b).
Match AND Mask	Integer	Bits 0 to 31 contain the AND mask to be used by the operating system engine during the check.
Match Value	Integer	Bits 0 to 31 contain the value to be compared by Operating system engine before the write.
Write Register Offset	Integer	Byte offset of the PCIe configuration space register to be modified. This offset shall be dword aligned (i.e. bits [1:0] are 00b).
Write AND Mask	Integer	Bits 0 to 31 contain the AND mask to be used by the operating system engine to modify the value to be written to the register indicated by Write Register Offset.
Write OR Mask	Integer	Bits 0 to 31 contain the OR mask to be used by the operating system engine to modify the value to be written to the register indicated by Write Register Offset.

6.2.9.5 _HPX Example

```

Method (_HPX, 0) {
    Return (Package(2){
        Package(6){           // PCI Setting Record
            0x00,             // Type 0
            0x01,             // Revision 1
            0x08,             // CacheLineSize in DWORDS
            0x40,             // LatencyTimer in PCI clocks
            0x01,             // Enable SERR (Boolean)
            0x00              // Enable PERR (Boolean)
        },
        Package(5){           // PCI-X Setting Record
            0x01,             // Type 1
            0x01,             // Revision 1
            0x03,             // Maximum Memory Read Byte Count
            0x04,             // Average Maximum Outstanding Split Transactions
            0x07              // Total Maximum Outstanding Split Transactions
        }
        Package(17){          // PCI Express Descriptor setting Record (Type 3)
            0x03,             // Type 3
            0x01,             // Revision 1
            0x01,             // Number of Register Descriptors
            0x01FF,           // Device/Port Type - All types in PCIe 4.0
            0x03,             // Function Type - All but VFs
            0x01,             // Configuration Space Location - Capability Structure
            0x10,             // PCIe Capability ID - PCI Express Cap Struct
            0x12,             // PCIe Capability Version - Applies to rev 2 and higher
            0x0000,           // PCIe Vendor ID - N/A
            0x00,             // VSEC/DVSEC ID - N/A
            0x00,             // VSEC/DVSEC Rev - N/A
            0x24,             // Match Register Offset - Device Cap 2
            0x00000002,       // Match AND Mask - Check Range B
            0x00000002       // Match Value - CTO Range B supported?
            0x28,             // Write Register Offset - Device Ctrl 2
            0xFFFFFFFF0,     // Write AND Mask - Clear CTO Range
            0x00000006       // Write OR Mask - Set CTO range 65 ms to 210 ms
        }
        Package(17){          // PCI Express Descriptor setting Record (Type 3)
            0x03,             // Type 3
            0x01,             // Revision 1
            0x01,             // Number of Register Descriptors
            0x01FF,           // Device/Port Type - All types in PCIe 4.0
            0x03,             // Function Type - All but VFs
            0x01,             // Configuration Space Location - Capability Structure
            0x10,             // PCIe Capability ID - PCI Express Cap Struct
            0x12,             // PCIe Capability Version - Applies to rev 2 and higher
            0x0000,           // PCIe Vendor ID - N/A
            0x00,             // VSEC/DVSEC ID - N/A
            0x00,             // VSEC/DVSEC Rev - N/A
            0x24,             // Match Register Offset - Device Cap 2
            0x00000006,       // Match AND Mask - Check Range B/C
            0x00000004       // Match Value - CTO Range B not supported but C is?
            0x28,             // Write Register Offset - Device Ctrl 2
            0xFFFFFFFF0,     // Write AND Mask - Clear CTO Range
            0x00000009       // Write OR Mask - Set CTO range 260 to 900 ms
        }
    })
}

```

(continues on next page)

(continued from previous page)

```

Package (17) {
    // PCI Express Descriptor setting Record (Type 3)
    0x03, // Type 3
    0x01, // Revision 1
    0x01, // Number of Register Descriptors
    0x01FF, // Device/Port Type - All types in PCIe 4.0
    0x03, // Function Type - All but VFs
    0x01, // Configuration Space Location - Capability Structure
    0x10, // PCIe Capability ID - PCI Express Cap Struct
    0x12, // PCIe Capability Version - Applies to rev 2 and higher
    0x0000, // PCIe Vendor ID - N/A
    0x00, // VSEC/DVSEC ID - N/A
    0x00, // VSEC/DVSEC Rev - N/A
    0x24, // Match Register Offset - Device Cap 2
    0x00000016, // Match AND Mask - Check Range B/C and CTO Disable
    0x00000010 // Match Value - CTO Disable support but no range B/C?
    0x28, // Write Register Offset - Device Ctrl 2
    0xFFFFFFFF, // Write AND Mask - Don't mask anything
    0x00000010 // Write OR Mask - Set CTO Disable
}
})
}

```

6.2.10 **_MAT (Multiple APIC Table Entry)**

This optional object evaluates to a buffer returning data in the format of a series of Multiple APIC Description Table (MADT) APIC Structure entries. This object can appear under an I/O APIC or processor object definition as processors may contain Local APICs. Specific types of MADT entries are meaningful to (in other words, processed by) OSPM when returned via the evaluation of this object as described in Table 5.21. Other entry types returned by the evaluation of **_MAT** are ignored by OSPM.

When **_MAT** appears under a Processor object, OSPM uses the ACPI processor ID in the entries returned from the object's evaluation to identify the entries corresponding to either the ACPI processor ID of the Processor object or the value returned by the **_UID** object under a Processor device.

Arguments:

None

Return Value:

A **Buffer** containing a list of Interrupt Controller Structures.

Example ASL for **_MAT usage:**

```

Scope (\_SB) {
    Device (PCI0) {
        // Root PCI Bus
        Name (_HID, EISAID("PNP0A03")) // Need \_HID for root device
        Device (P64A) {
            // P64A ACPI
            Name (_ADR, 0)
            OperationRegion (OPRM, SystemMemory,
                Offset in system memory of Interrupt Controller Structures,
                Length in bytes)
            Field (OPRM, ByteAcc, NoLock, Preserve) {
                MATD, Length in bits
            }
            Method (_MAT, 0) {
                Return (MATD)
            }
        }
    }
}

```

(continues on next page)

(continued from previous page)

```

    }
    ...
} // end P64A
...
} // end PCI0
...
} // end scope SB

```

6.2.11 _OSC (Operating System Capabilities)

This optional object is a control method that is used by OSPM to communicate to the platform the feature support or capabilities provided by a device's driver. This object is a child object of a device and may also exist in the _SB scope, where it can be used to convey platform wide OSPM capabilities. When supported, _OSC is invoked by OSPM immediately after placing the device in the D0 power state. Device specific objects are evaluated *after* _OSC invocation. This allows the values returned from other objects to be predicated on the OSPM feature support / capability information conveyed by _OSC. OSPM may evaluate _OSC multiple times to indicate changes in OSPM capability to the device but this may be precluded by specific device requirements. As such, _OSC usage descriptions in *ACPI-Defined Devices and Device-Specific Objects*, or other governing specifications describe superseding device specific _OSC capabilities and / or preclusions.

_OSC enables the platform to configure its ACPI namespace representation and object evaluations to match the capabilities of OSPM. This enables legacy operating system support for platforms with new features that make use of new namespace objects that if exposed would not be evaluated when running a legacy OS. _OSC provides the capability to transition the platform to native operating system support of new features and capabilities when available through dynamic namespace reconfiguration. _OSC also allows devices with Compatible IDs to provide superset functionality when controlled by their native (For example, _HID matched) driver as appropriate objects can be exposed accordingly as a result of OSPM's evaluation of _OSC.

Arguments: (4)

- Arg0 - A **Buffer** containing a UUID
- Arg1 - An **Integer** containing a Revision ID of the buffer format
- Arg2 - An **Integer** containing a count of entries in Arg3
- Arg3 - A **Buffer** containing a list of DWORD capabilities

Return Value:

- A **Buffer** containing a list of capabilities

Argument Information

Arg0: UUID - used by the platform in conjunction with Revision ID to ascertain the format of the Capabilities buffer.

Arg1: Revision ID - The revision of the Capabilities Buffer format. The revision level is specific to the UUID.

Arg2: Count - Number of DWORDs in the Capabilities Buffer in Arg3

Arg3: Capabilities Buffer - Buffer containing the number of DWORDs indicated by Count. The first DWORD of this buffer contains standard bit definitions as described below. Subsequent DWORDs contain UUID-specific bits that convey to the platform the capabilities and features supported by OSPM. Successive revisions of the Capabilities Buffer must be backwards compatible with earlier revisions. Bit ordering cannot be changed.

Capabilities Buffers are device-specific and as such are described under specific device definitions. See *ACPI-Defined Devices and Device-Specific Objects* for any _OSC definitions for ACPI devices. The format of the Capabilities Buffer and behavior rules may also be specified by OEMs and IHVs for custom devices and other interface or device governing bodies for example, the PCI SIG.

The first DWORD in the capabilities buffer is used to return errors defined by `_OSC`. This DWORD must always be present and may not be redefined/reused by unique interfaces utilizing `_OSC`.

- Bit [0]- Query Support Flag. If set, the `_OSC` invocation is a query by OSPM to determine or negotiate with the platform the combination of capabilities for which OSPM may take control. In this case, OSPM sets bits in the subsequent DWORDs to specify the capabilities for which OSPM intends to take control. If clear, OSPM is attempting to take control of the capabilities corresponding to the bits set in subsequent DWORDs. OSPM may only take control of capabilities as indicated by the platform by the result of the query.
- Bit [1] - Always clear (0).
- Bit [2] - Always clear (0).
- Bit [3] - Always clear (0).
- All others - reserved.

Return Value Information

Capabilities Buffer (Buffer) - The platform acknowledges the Capabilities Buffer by returning a buffer of DWORDs of the same length. Set bits indicate acknowledgment that OSPM may take control of the capability and cleared bits indicate that the platform either does not support the capability or that OSPM may not assume control.

The first DWORD in the capabilities buffer is used to return errors defined by `_OSC`. This DWORD must always be present and may not be redefined/reused by unique interfaces utilizing `_OSC`.

- Bit [0] - Reserved (not used)
- Bit [1] - `_OSC` failure. Platform Firmware was unable to process the request or query. Capabilities bits may have been masked.
- Bit [2] - Unrecognized UUID. This bit is set to indicate that the platform firmware does not recognize the UUID passed in via `Arg0`. Capabilities bits are preserved.
- Bit [3] - Unrecognized Revision. This bit is set to indicate that the platform firmware does not recognize the Revision ID passed in via `Arg1`. Capabilities bits beyond those comprehended by the firmware will be masked.
- Bit [4] - Capabilities Masked. This bit is set to indicate that capabilities bits set by driver software have been cleared by platform firmware.
- All others - reserved.

Note: OSPM must not use the results of `_OSC` evaluation to choose a compatible device driver. OSPM must use `_HID`, `_CID`, or native enumerable bus device identification mechanisms to select an appropriate driver for a device.

The platform may issue a **Notify**(device, 0x08) to inform OSPM to re-evaluate `_OSC` when the availability of feature control changes. Platforms must **not** rely, however, on OSPM to evaluate `_OSC` after issuing a **Notify**** for proper operation as OSPM cannot guarantee the presence of a target entity to receive and process the **Notify** for the device. For example, a device driver for the device may not be loaded at the time the **Notify** is signaled. Further, the issuance and processing rules for notification of changes in the Capabilities Buffer is device specific. As such, the allowable behavior is governed by device specifications either in *ACPI-Defined Devices and Device-Specific Objects*, for ACPI-define devices, or other OEM, IHV, or device governing body's' device specifications.

It is permitted for `_OSC` to return all bits in the Capabilities Buffer cleared. An example of this is when significant time is required to disable platform-based feature support. The platform may then later issue a **Notify** to tell OSPM to re-evaluate `_OSC` to take over native control. This behavior is also device specific but may also rely on specific OS capability.

In general, platforms should support both OSPM taking and relinquishing control of specific feature support via multiple invocations of `_OSC` but the required behavior may vary on a per device basis.

Since platform context is lost when the platform enters the S4 sleeping state, OSPM must re-evaluate _OSC upon wake from S4 to restore the previous platform state. This requirement will vary depending on the device specific _OSC functionality.

6.2.11.1 Rules for Evaluating _OSC

This section defines when and how the OS must evaluate _OSC, as well as restrictions on firmware implementation.

6.2.11.1.1 Query Flag

If the Query Support Flag (Capabilities DWORD 1, bit 0) is set by the OS when evaluating _OSC, no hardware settings are permitted to be changed by firmware in the context of the _OSC call. It is strongly recommended that the OS evaluate _OSC with the Query Support Flag set until _OSC returns the Capabilities Masked bit clear, to negotiate the set of features to be granted to the OS for native support; a platform may require a specific combination of features to be supported natively by an OS before granting native control of a given feature. After negotiation with the query flag set, the OS should evaluate without it so that any negotiated values can be made effective to hardware.

6.2.11.1.2 Evaluation Conditions

The OS must evaluate _OSC under the following conditions:

During initialization of any driver that provides native support for features described in the section above. These features may be supported by one or many drivers, but should only be evaluated by the main bus driver for that hierarchy. Secondary drivers must coordinate with the bus driver to install support for these features. Drivers may not relinquish control of features previously obtained (i.e., bits set in Capabilities DWORD3 after the negotiation process must be set on all subsequent negotiation attempts.)

When a Notify(<device>, 8) is delivered to the PCI Host Bridge device.

Upon resume from S4. Platform firmware will handle context restoration when resuming from S1-S3.

6.2.11.1.3 Sequence of _OSC Calls

The following rules govern sequences of calls to _OSC that are issued to the same host bridge and occur within the same boot.

- The OS is permitted to evaluate _OSC an arbitrary number of times.
- If the OS declares support of a feature in the Support Field in one call to _OSC, then it must preserve the set state of that bit (declaring support for that feature) in all subsequent calls.
- If the OS is granted control of a feature in the Control Field in one call to _OSC, then it must preserve the set state of that bit (requesting that feature) in all subsequent calls.
- Firmware may not reject control of any feature it has previously granted control to.
- There is no mechanism for the OS to relinquish control of a feature previously requested and granted.

6.2.11.2 Platform-Wide OSPM Capabilities

OSPM evaluates _SB_OSC to convey platform-wide OSPM capabilities to the platform. Argument definitions are as follows:

Arguments(4):

- Arg0 - UUID (Buffer): 0811B06E-4A27-44F9-8D60-3CBBC22E7B48
- Arg1 - Revision ID (Integer): 1
- Arg2 - Count of Entries in Arg3 (Integer): 2
- Arg3 - DWORD capabilities (Buffer):
 - First DWORD: as described in [Section 6.2.11](#)
 - Second DWORD: see the following table.

Table 6.13: Platform-Wide _OSC Capabilities DWORD 2

Bits	Field Name	Definition
0	Processor Aggregator Device Support	This bit is set if OSPM supports the Processor Aggregator device as described in Section 8.5
1	_PPC _OST Processing Support	This bit is set if OSPM will evaluate the _OST object defined under a processor as a result of _PPC change notification (Notify 0x80).
2	_PR3 Support	This bit is set if OSPM supports reading _PR3 and using power resources to switch power. Note this handshake translates to an operating model that the platform and OSPM supports both the power model containing both D3hot and D3.
3	Insertion / Ejection _OST Processing Support	This bit is set if OSPM will evaluate the _OST object defined under a device when processing insertion and ejection source event codes.
4	APEI Support	This bit is set if OSPM supports the ACPI Platform Error Interfaces. See Section 18
5	CPPC Support	This bit is set if OSPM supports controlling processor performance via the interfaces described in the _CPC object.
6	CPPC 2 Support	This bit is set if OSPM supports revision 2 of the _CPC object.
7	Platform Coordinated Low Power Idle Support	This bit is set if OSPM supports platform coordinated low power idle states (see note below)*.
8	OS Initiated Low Power Idle Support	This bit is set if OSPM supports OS initiated low power idle states. *(see note, below).
9	Fast Thermal Sampling support	This bit is set if OSPM supports _TFP.
10	Greater Than 16 p-state support	This bit is set if OSPM supports greater than 16 p-states. If clear, no more than 16 p-states are supported.
11	Generic Event Device support	This bit is set if OSPM supports parsing of the generic event device.

continues on next page

Table 6.13 – continued from previous page

12	Diverse CPPC Highest Optimization Support	<p>This bit is set if OSPM can process processor device notifications for changes in CPPC Highest Performance. It also indicates support for optimizing for performance domains with diverse Highest Performance capabilities.</p> <p>Potential OS optimizations for diverse CPPC highest performance include but are not limited to placement of work on specific logical processors yielding a performance or power benefit.</p> <p>Note: These optimizations are independent of the platform’s existing ability to expose diverse Highest Performance to OSPM as well as OSPM support for the MADT GICC’s Processor Power Efficiency Class.</p>
13	Interrupt ResourceSource support	<p>This bit is set if OSPM supports the usage of the ResourceSource in the extended interrupt descriptor. As part of the handshake provided through _OSC, the platform will indicate to the OS whether or not it supports usage of ResourceSource. If not set, the OS may choose to ignore the ResourceSource parameter in the extended interrupt descriptor.</p>
14	Flexible Address Space for CPPC Registers	<p>This bit is set if OSPM supports any CPPC register being located in PCC, SystemMemory, SystemIO, or Functional Fixed Hardware address spaces. If not set, per-register restrictions described in ACPI Specification 6.1 apply.</p>
15	GHES_ASSIST Support	<p>This bit is set if OSPM supports the GHES_ASSIS Flag in HEST Error Structures. See Section 18</p>
16	Multi PCC channel support for CPPC	<p>The OSPM sets this bit when it supports multiple PCC channels for the CPPC protocol.</p>
17	Generic Initiator Support	<p>This bit is set if OSPM supports the Generic Initiator Affinity Structure in SRAT.</p>
18	Native USB4 Support	<p>The OS sets this bit to indicate support for an OSPM-native USB4 Connection Manager, which handles USB4 connection events and link management.</p>
19	Battery Charge Limiting Support	<p>The OS sets this bit to indicate support for Battery Charge Limiting. This bit promises that the platform will advertise “true” state of charge to the OSPM at all times.</p>
20	PCI BAR Target GAS Support	<p>The OS sets this bit to indicate support for the PCI BAR Target GAS structure, as described in Table 5.2.</p>
21	Platform Runtime Mechanism Support	<p>The OS sets this bit to indicate support for the Platform Runtime Mechanism (PRM). See Links to ACPI-Related Documents (https://uefi.org/acpi) under the heading “Platform Runtime Mechanism Table”.</p>
22	Functional Fixed Hardware	<p>The OS sets this bit to indicate support for the usage of Functional Fixed Hardware (FFixedHW) Operation Regions.</p>
31:23		<i>Reserved (must be 0)</i>

Note: As part of the handshake provided through _OSC, the OS will pass in flags to indicate whether it supports Platform Coordinated Low Power Idle or OS Initiated Low Power Idle or both (see [Section 8.4.3.2](#)), through flags 7 and 8. The platform will indicate which of the modes it supports in its response by clearing flags that are not supported. If both are supported, the default is platform coordinated and OSPM can switch the platform to OS Initiated via a processor architecture specific mechanism. By setting either flag 7 or 8 or both, the OSPM is asserting it supports any objects associated with Low Power Idle states (see [Section 8.4.3.3](#), [Table 8.16](#), and [Section 7.2.5](#)), and supports a

Return Value Information

Capabilities Buffer (Buffer) - The platform acknowledges the Capabilities Buffer by returning a buffer of DWORDs of the same length. Set bits indicate acknowledgment and cleared bits indicate that the platform does not support the capability.

6.2.11.3 Operating System Capabilities (_OSC) for USB

Platform hardware and operating systems with support for USB4 require a few controls for passing information back and forth. The following definition is used to convey this information.

Along with the Platform-Wide OSPM Capabilities defined in Section 6.2.11.2, this _OSC interface is implemented within the same scope, and therefore the same _OSC Control Method, using a different UUID value. If the platform does not support USB4, the UUID defined in this section should not be supported.

Note that if control of any features described in Table 6.15 are granted to OSPM, system firmware must not attempt to control any other features not granted to OSPM; only one Connection Manager is permitted to be active at any point in time. OSPM evaluates _SB._OSC to manage USB capabilities within the platform. Argument definitions are as follows.

Arguments (4):

Arg0 – UUID (Buffer): 23A0D13A-26AB-486C-9C5F-0FFA525A575A

Arg1 – Revision ID (Integer): 1

Arg2 – Count of entries (DWORDS) in Arg3 (Integer): 3

Arg3 – DWORD capabilities buffer:

- First DWORD: As described in Section 6.2.11.1
- Second DWORD: OSPM Support Field for USB. See Table 6.14 for details.
- Third DWORD: OSPM Control Field for USB. See Table 6.15 for details.

Note:: OSPM must re-invoke _OSC during S4 resume.

Table 6.14: **OSPM USB Support Field**

Support Field Bit Offset	Interpretation
5:0	OS-Supported USB4 Version: The revision of the USB4 specification supported by OSPM. 0: USB4 Version 1.0 All other values are reserved.
31:6	<i>Reserved</i>

Table 6.15: **OSPM USB Control Field**

Bits	Field Name	Definition
0	USB Tunneling	OSPM requests control of USB tunneling across USB4 connections via the OSPM-native Connection Manager. Once OSPM receives control of this feature, it must not relinquish support to the platform.

continues on next page

Table 6.15 – continued from previous page

1	DisplayPort Tunneling	OSPM requests control of DisplayPort tunneling across USB4 connections via the OSPM-native Connection Manager. Once OSPM receives control of this feature, it must not relinquish support to the platform.
2	PCI Express Tunneling	OSPM requests control of PCI Express tunneling across USB4 connections via the OSPM-native Connection Manager. Once OSPM receives control of this feature, it must not relinquish support to the platform.
3	Inter-domain USB4	Inter-domain USB4 protocol: OSPM requests control of inter-domain USB4 connections via the OSPM-native Connection Manager. Once OSPM receives control of this feature, it must not relinquish support to the platform.
31:4	<i>Reserved</i>	

Return Value Information

Capabilities Buffer (Buffer): The platform acknowledges the Capabilities Buffer by returning a buffer of DWORDs of the same length. Preserved bits in the Control Field convey control from the platform to OSPM, while masked/cleared bits in the Control Field indicate that the platform does not permit OSPM control of the respective capability or feature.

6.2.12 _PRS (Possible Resource Settings)

This optional object evaluates to a byte stream that describes the possible resource settings for the device. When describing a platform, specify a _PRS for all the configurable devices. Static (non-configurable) devices do not specify a _PRS object. The information in this package is used by OSPM to select a conflict-free resource allocation without user intervention. This method must not reference any operation regions that have not been declared available by a _REG method.

The format of the data in a _PRS object follows the same format as the _CRS object (for more information, see Section 6.2.2).

If the device is disabled when _PRS is called, it must remain disabled.

Arguments:

None

Return Value:

A Buffer containing a Resource Descriptor byte stream

6.2.13 _PRT (PCI Routing Table)

PCI interrupts are inherently non-hierarchical. PCI interrupt pins are wired to interrupt inputs of the interrupt controllers. The _PRT object provides a mapping from PCI interrupt pins to the interrupt inputs of the interrupt controllers. The _PRT object is required under all PCI root bridges. _PRT evaluates to a package that contains a list of packages, each of which describes the mapping of a PCI interrupt pin.

Arguments:

None

Return Value:

A **Package** containing variable-length list of PCI interrupt mapping packages, as described below

Note: The PCI function number in the Address field of the _PRT packages must be 0xFFFF, indicating “any” function number or “all functions”.

The _PRT mapping packages have the fields listed in the table below.

Table 6.16: Mapping Fields

Field	Type	Description
Address	DWORD	The address of the device (uses the same format as _ADR).
Pin	Byte	The PCI pin number of the device (0-INTA, 1-INTB, 2-INTC, 3-INTD).
Source	NamePath Or Byte	Name of the device that allocates the interrupt to which the above pin is connected. The name can be a fully qualified path, a relative path, or a simple name segment that utilizes the namespace search rules. Note: This field is a NamePath and not a String literal, meaning that it should not be surrounded by quotes. If this field is the integer constant Zero (or a Byte value of 0), then the interrupt is allocated from the global interrupt pool.
Source Index	DWORD	Index that indicates which resource descriptor in the resource template of the device pointed to in the Source field this interrupt is allocated from. If the Source field is the Byte value zero, then this field is the global system interrupt number to which the pin is connected.

There are two ways that _PRT can be used. Typically, the interrupt input that a given PCI interrupt is on is configurable. For example, a given PCI interrupt might be configured for either IRQ 10 or 11 on an 8259 interrupt controller. In this model, each interrupt is represented in the ACPI namespace as a PCI Interrupt Link Device.

These objects have _PRS, _CRS, _SRS, and _DIS control methods to allocate the interrupt. Then, OSPM handles the interrupts not as interrupt inputs on the interrupt controller, but as PCI interrupt pins. The driver looks up the device's pins in the _PRT to determine which device objects allocate the interrupts. To move the PCI interrupt to a different interrupt input on the interrupt controller, OSPM uses _PRS, _CRS, _SRS, and _DIS control methods for the PCI Interrupt Link Device.

In the second model, the PCI interrupts are hardwired to specific interrupt inputs on the interrupt controller and are not configurable. In this case, the Source field in _PRT does not reference a device, but instead contains the value zero, and the Source Index field contains the global system interrupt to which the PCI interrupt is hardwired.

6.2.13.1 Example: Using _PRT to Describe PCI IRQ Routing

The following example describes two PCI slots and a PCI video chip. Notice that the interrupts on the two PCI slots are wired differently (barber-poled):

```
Scope (\_SB) {
    Device(LNKA) {
        Name(_HID, EISAID("PNP0C0F")) // PCI interrupt link
        Name(_UID, 1)
        Name(_PRS, ResourceTemplate() {
            Interrupt(ResourceProducer,...) {10,11} // IRQs 10,11
        })
        Method(_DIS) {...}
        Method(_CRS) {...}
        Method(_SRS, 1) {...}
    }
    Device(LNKB) {
        Name(_HID, EISAID("PNP0C0F")) // PCI interrupt link
        Name(_UID, 2)
        Name(_PRS, ResourceTemplate() {
            Interrupt(ResourceProducer,...) {11,12} // IRQs 11,12
        })
        Method(_DIS) {...}
    }
}
```

(continues on next page)

(continued from previous page)

```

        Method(_CRS) {...}
        Method(_SRS, 1) {...}
    }
    Device(LNKC) {
        Name(_HID, EISAID("PNP0C0F"))           // PCI interrupt link
        Name(_UID, 3)
        Name(_PRS, ResourceTemplate() {
            Interrupt(ResourceProducer, ...) {12,14} // IRQs 12,14
        })
        Method(_DIS) {...}
        Method(_CRS) {...}
        Method(_SRS, 1) {...}
    }
    Device(LNKD) {
        Name(_HID, EISAID("PNP0C0F"))           // PCI interrupt link
        Name(_UID, 4)
        Name(_PRS, ResourceTemplate() {
            Interrupt(ResourceProducer, ...) {10,15} // IRQs 10,15
        })
        Method(_DIS) {...}
        Method(_CRS) {...}
        Method(_SRS, 1) {...}
    }
    Device(PCI0) {
        ...
        Name(_PRT, Package{ // A fully qualified pathname can be used, or a
            // osimple name segment utilizing the search rules.
            Package{0x0004FFFF, 0, \\_SB_.LNKA, 0}, // Slot 1, INTA
            Package{0x0004FFFF, 1, \\_SB_.LNKB, 0}, // Slot 1, INTB
            Package{0x0004FFFF, 2, \\_SB_.LNKC, 0}, // Slot 1, INTC
            Package{0x0004FFFF, 3, \\_SB_.LNKD, 0}, // Slot 1, INTD
            Package{0x0005FFFF, 0, LNKB, 0},       // Slot 2, INTA
            Package{0x0005FFFF, 1, LNKC, 0},       // Slot 2, INTB
            Package{0x0005FFFF, 2, LNKD, 0},       // Slot 2, INTC
            Package{0x0005FFFF, 3, LNKA, 0},       // Slot 2, INTD
            Package{0x0006FFFF, 0, LNKC, 0}        // Video, INTA
        })
    }
}

```

6.2.14 _PXM (Proximity)

This optional object is used to describe proximity domain associations within a machine. `_PXM` evaluates to an integer that identifies a device as belonging to a Proximity Domain defined in the System Resource Affinity Table (SRAT). OSPM assumes that two devices in the same proximity domain are tightly coupled. OSPM could choose to optimize its behavior based on this. For example, in a system with four processors and six memory devices, there might be two separate proximity domains (0 and 1), each with two processors and three memory devices. In this case, the OS may decide to run some software threads on the processors in proximity domain 0 and others on the processors in proximity domain 1. Furthermore, for performance reasons, it could choose to allocate memory for those threads from the memory devices inside the proximity domain common to the processor and the memory device rather than from a memory device outside of the processor's proximity domain.

Children of a device belong to the same proximity domain as their parent unless they contain an overriding `_PXM`. Proximity domains do not imply any ejection relationships.

OSPM shall make no assumptions about the proximity or nearness of different proximity domains. The difference

between two integers representing separate proximity domains does not imply distance between the proximity domains (in other words, proximity domain 1 is not assumed to be closer to proximity domain 0 than proximity domain 6).

If the Local APIC ID / Local SAPIC ID / Local x2APIC ID or the GICC ACPI Processor UID of a dynamically added processor is not present in the System Resource Affinity Table (SRAT), a `_PXM` object must exist for the processor's device or one of its ancestors in the ACPI Namespace. See [Section 5.2.16](#) for more information.

Arguments:

None

Return Value:

An **Integer** (DWORD) containing a proximity domain identifier.

6.2.15 `_SLI` (System Locality Information)

The System Locality Information Table (SLIT) table defined in *Generic Initiator Affinity Structure* provides relative distance information between all System Localities for use during OS initialization.

The value of each Entry[*i,j*] in the SLIT table, where *i* represents a row of a matrix and *j* represents a column of a matrix, indicates the relative distances from System Locality / Proximity Domain *i* to every other System Locality *j* in the system (including itself).

The *i,j* row and column values correlate to the value returned by the `_PXM` object in the ACPI namespace. See *`_PXM` (Proximity)* for more information.

Dynamic runtime reconfiguration of the system may cause the distance between System Localities to change.

`_SLI` is an optional object that enables the platform to provide the OS with updated relative System Locality distance information at runtime. `_SLI` provide OSPM with an update of the relative distance from System Locality *i* to all other System Localities in the system.

Arguments:

None

Return Value:

A **Buffer** containing a system locality information table

If System Locality *i* \geq N, where N is the number of System Localities, the `_SLI` method returns a buffer that contains these relative distances:

```
[ (i, 0), (i, 1), ..., (i, i-1), (i, i), (0, i), (1, i), ..., (i-1, i), (i, i) ]
```

If System Locality *i* $<$ N, the `_SLI` method returns a buffer that contains these relative distances:

```
[ (i, 0), (i, 1), ..., (i, i), ..., (i, N-1), (0, i), (1, i), ..., (i, i), ..., (N-1, i) ]
```

Note: (*i, i*) is always a value of 10.

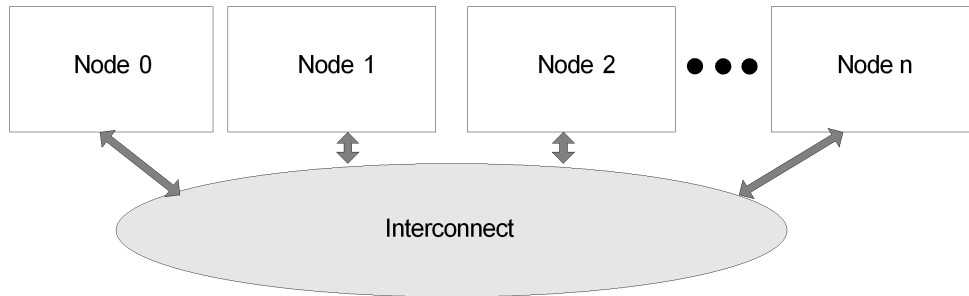

Fig. 6.5: System Locality information Table

The System Locality Information Table diagrams a 4-node system where the nodes are numbered 0 through 3 (Node n = Node 3) and the granularity is at the node level for the NUMA distance information. In this example we assign System Localities / Proximity Domain numbers equal to the node numbers (0-3). The NUMA relative distances between proximity domains as implemented in this system are described in the matrix represented in *Example Relative Distances Between Proximity Domains*. Proximity Domains are represented by the numbers in the top row and left column. Distances are represented by the values in cells internal in the table from the domains.

Table 6.17: Example Relative Distances Between Proximity Domains

ProximityDomain	0	1	2	3
0	10	15	20	18
1	15	10	16	24
2	20	16	10	12
3	18	24	12	10

An example of these distances between proximity domains encoded in a System Locality Information Table for consumption by OSPM at boot time is described in the table below.

Table 6.18: Example System Locality Information Table

Field	Byte Length	Byte Offset	Description
Header			
Signature	4	0	'SLIT'.
Length	4	4	60
Revision	1	8	1
Checksum	1	9	Entire table must sum to zero.
OEMID	6	10	OEM ID.
OEM Table ID	8	16	For the System Locality Information Table, the table ID is the manufacturer model ID.
OEM Revision	4	24	OEM revision of System Locality Information Table for supplied OEM Table ID.
Creator ID	4	28	Vendor ID of utility that created the table. For the DSDT, RSDT, SSDT, and PSDT tables, this is the ID for the ASL Compiler.
Creator Revision	4	32	Revision of utility that created the table. For the DSDT, RSDT, SSDT, and PSDT tables, this is the revision for the ASL Compiler.
Creator Revision			
Number of System Localities	8	36	4
Entry[0][0]	1	44	10
Entry[0][1]	1	45	15
Entry[0][2]	1	46	20
Entry[0][3]	1	47	18
Entry[1][0]	1	48	15
Entry[1][1]	1	49	10
Entry[1][2]	1	50	16
Entry[1][3]	1	51	24
Entry[2][0]	1	52	20
Entry[2][1]	1	53	16
Entry[2][2]	1	54	10
Entry[2][3]	1	55	12
Entry[3][0]	1	56	18
Entry[3][1]	1	57	24
Entry[3][2]	1	58	12
Entry[3][3]	1	59	10

If a new “Node 4” is added, then the following table represents the updated system’s NUMA relative distances of proximity domains.

Table 6.19: Example Relative Distances Between Proximity Domains
- 5 Node

Proximity Domain	0	1	2	3	4
0	10	15	20	18	17
1	15	10	16	24	21
2	20	16	10	12	14
3	18	24	12	10	23
4	17	21	14	23	10

The new node's `_SLI` object would evaluate to a buffer containing [17,21,14,23,10,17,21,14,23,10].

Note: Some systems support interleave memory across the nodes. The SLIT representation of these systems is implementation specific.

6.2.16 `_SRS` (Set Resource Settings)

This optional control method takes one byte stream argument that specifies a new resource allocation for a device. The resource descriptors in the byte stream argument must be specified exactly as listed in the `_CRS` byte stream - meaning that the identical resource descriptors must appear in the identical order, resulting in a buffer of exactly the same length. Optimizations such as changing an `IRQ` descriptor to an `IRQNoFlags` descriptor (or vice-versa) must not be performed. Similarly, changing `StartDependentFn` to `StartDependentFnNoPri` is not allowed. A `_CRS` object can be used as a template to ensure that the descriptors are in the correct format. For more information, see the `_CRS` object definition.

The settings must take effect before the `_SRS` control method returns.

This method must not reference any operation regions that have not been declared available by a `_REG` method.

If the device is disabled, `_SRS` enables the device at the specified resources. `_SRS` is not used to disable a device; use the `_DIS` control method instead.

Arguments: (1)

Arg0 - A **Buffer** containing a Resource Descriptor byte stream

Return Value:

None

6.2.17 `_CCA` (Cache Coherency Attribute)

The `_CCA` object returns whether or not a bus-master device supports hardware managed cache coherency. Expected values are 0 to indicate it is not supported, and 1 to indicate that it is supported. All other values are reserved.

On platforms for which existing default cache-coherency behavior of the OS is not adequate, `_CCA` enables the OS to adapt to the differences. If used, `_CCA` must be included under all bus-master-capable devices defined as children of `_SB`, to ensure that the operating system knows when it can rely on hardware managed cache coherency. The value of `_CCA` is inherited by all descendants of these devices, so it need not be repeated for their children devices and will be ignored by OSPM if it is provided there. This includes slave devices on a shared DMA controller; thus these DMA controllers must also be defined in the namespace under the System Bus and include a `_CCA` object.

If a device indicates it does not have hardware cache coherency support, then OSPM must use a software cache flushing algorithm to ensure stale or invalid data is not accessed from the caches.

`_CCA` objects are only relevant for devices that can access CPU-visible memory, such as devices that are DMA capable. On ARM based systems, the `_CCA` object must be supplied all such devices. On Intel platforms, if the `_CCA` object is not supplied, the OSPM will assume the devices are hardware cache coherent.

Arguments:

None

Return Value:

An **Integer** indicating the device's support for hardware cache coherency:

<pre>0 - The device does not have hardware managed cache coherency 1 - The device has hardware managed cache coherency Other Values - Reserved</pre>
--

Note: There are restrictions related to when this object is evaluated which have implications for implementing this object as a control method. The `_CCA` method must only access Operation Regions that have been indicated to be available as defined by the `_REG` method. The `_REG` method is described in *`_REG (Region)`*.

6.2.17.1 `_CCA` Example ASL:

```
Scope (\_SB) {
    ...
    Device (XHCI) {
        ...
        Name (_CCA, ZERO)    // Cache-incoherent bus-master, child of \_SB
        ...
    }
    ...
    Device (PCI0) {        // Root PCI Bus
        ...
        Name (_CCA, ONE)    // Cache-coherent bus-master, child of \_SB
        ...
        Device (PRT0) {
            ...            // Bus-master-capable, not a child of \_SB
            ...            // Will inherit coherency from PCI0, no \_CCA required
            Device (NIC0) {
                ...        // Bus-master-capable, not a child of \_SB
                ...        // Will inherit coherency from PRT0, no \_CCA required
            }
        }
    }
    ...
    Device (SDHC) {
        ...
        Name (_CCA, ONE)    // Cache-coherent bus-master-capable, child of \_SB
        ...
    }
    ...
    Device (GPIO) {
        ...                // Not bus-master-capable
        ...                // \_CCA not valid
    }
    ...
}
```

(continues on next page)

(continued from previous page)

```

Device (DMAC) {
    ...                // DMA controller; \_CCA must be specified
    Name (_CCA, ONE)   // Cache coherent bus-master, child of \_SB
    ...
}
...
Device (SPI1) {
    ...
    Name (_CRS, ResourceTemplate()
        {
            FixedDMA(...) // Sharing the DMA, thus inherits coherency from it
            ...
            ...
        })
    ...                // \_CCA not valid
}
}

```

6.2.18 _HMA(Heterogeneous Memory Attributes)

The Heterogeneous Memory Attributes Table (HMAT) defined in *Heterogeneous Memory Attribute Table (HMAT)* provides Heterogeneous Memory Attributes. Dynamic runtime reconfiguration of the system may cause proximities domains or memory attributes to change. If the “Reservation Hint” is set, new HMAT update shall not reset the “Reservation Hint” unless the memory range is removed.

_HMA is an optional object that enables the platform to provide the OS with updated Heterogeneous Memory Attributes information at runtime. _HMA provides OSPM with the latest HMAT in entirety overriding existing HMAT.

Arguments:

None

Return Value:

A **Buffer** containing entire HMAT.

Example ASL for _HMA usage:

```

Scope (\_SB) {
    Device (Dev1) {
        ...
    }
    Device (Dev2) {
        ...
    }
    Method (_HMA, 0) {
        Return (HMAD)
    }
}
// end of \_SB scope

```

6.3 Device Insertion, Removal, and Status Objects

The objects defined in this section provide mechanisms for handling dynamic insertion and removal of devices and for determining device and notification processing status.

Device insertion and removal objects are also used for docking and undocking mobile platforms to and from a peripheral expansion dock. These objects give information about whether or not devices are present, which devices are physically in the same device (independent of which bus the devices live on), and methods for controlling ejection or interlock mechanisms.

The system is more stable when removable devices have a software-controlled, VCR-style ejection mechanism instead of a “surprise-style” ejection mechanism. In this system, the eject button for a device does not immediately remove the device, but simply signals the operating system. OSPM then shuts down the device, closes open files, unloads the driver, and sends a command to the hardware to eject the device.

1. If the device is physically inserted while the system is in the working state (in other words, hot insertion), the hardware generates a general-purpose event.
2. The control method servicing the event uses the `Notify(device,0)` command to inform OSPM of the bus that the new device is on or the device object for the new device. If the `Notify` command points to the device object for the new device, the control method must have changed the device’s status returned by `_STA` to indicate that the device is now present. The performance of this process can be optimized by having the object of the `Notify` as close as possible, in the namespace hierarchy, to where the new device resides. The `Notify` command can also be used from the `_WAK` control method (see [Section 7.4.5](#)) to indicate device changes that may have occurred while the system was sleeping. For more information about the `Notify` command, see [Section 5.6.6](#).
3. OSPM uses the identification and configuration objects to identify, configure, and load a device driver for the new device and any devices found below the device in the hierarchy.
4. If the device has a `_LCK` control method, OSPM may later run this control method to lock the device.

The new device referred to in step 2 need not be a single device, but could be a whole tree of devices. For example, it could point to the PCI-PCI bridge docking connector. OSPM will then load and configure all devices it found below that bridge. The control method can also point to several different devices in the hierarchy if the new devices do not all live under the same bus. (in other words, more than one bus goes through the connector).

For removing devices, ACPI supports both hot removal (system is in the `S0` state), and warm removal (system is in a sleep state: `S1-S4`). This is done using the `_EJx` control methods. Devices that can be ejected include an `_EJx` control method for each sleeping state the device supports (a maximum of 2 `_EJx` objects can be listed). For example, hot removal devices would supply an `_EJ0`; warm removal devices would use one of `_EJ1-EJ4`. These control methods are used to signal the hardware when an eject is to occur.

The sequence of events for dynamically removing a device goes as follows:

1. The eject button is pressed and generates a general-purpose event. (If the system was in a sleeping state, it should wake the system).
2. The control method for the event uses the `Notify(device, 3)` command to inform OSPM which specific device the user has requested to eject. `Notify` does not need to be called for every device that may be ejected, but for the top-level device. Any child devices in the hierarchy or any ejection-dependent devices on this device (as described by `_EJD`, below) are automatically removed.
3. The OS shuts down and unloads devices that will be removed.
4. If the device has a `_LCK` control method, OSPM runs this control method to unlock the device.
5. The OS looks to see what `_EJx` control methods are present for the device. If the removal event will cause the system to switch to battery power (in other words, an undock) and the battery is low, dead, or not present, OSPM uses the lowest supported sleep state `_EJx` listed; otherwise it uses the highest state `_EJx`. Having made this decision, OSPM runs the appropriate `_EJx` control method to prepare the hardware for eject.

6. Warm removal requires that the system be put in a sleep state. If the removal will be a warm removal, OSPM puts the system in the appropriate Sx state. If the removal will be a hot removal, OSPM skips to step 8, below.
7. For warm removal, the system is put in a sleep state. Hardware then uses any motors, and so on, to eject the device. Immediately after ejection, the hardware transitions the system to S0. If the system was sleeping when the eject notification came in, the OS returns the system to a sleeping state consistent with the user's wake settings.
8. OSPM calls `_STA` to determine if the eject successfully occurred. (In this case, control methods do not need to use the `Notify(device,3)` command to tell OSPM of the change in `_STA`) If there were any mechanical failures, `_STA` returns 3: device present and not functioning, and OSPM informs the user of the problem.

Note: This mechanism is the same for removing a single device and for removing several devices, as in an undock.

ACPI does not disallow surprise-style removal of devices; however, this type of removal is not recommended because system and data integrity cannot be guaranteed when a surprise-style removal occurs. Because the OS is not informed, its device drivers cannot save data buffers and it cannot stop accesses to the device before the device is removed. To handle surprise-style removal, a general-purpose event must be raised. Its associated control method must use the `Notify` command to indicate which bus the device was removed from.

The device insertion and removal objects are listed in the table below.

Table 6.20: **Device Insertion, Removal, and Status Objects**

Object	Description
<code>_EDL</code>	Object that evaluates to a package of namespace references of device objects that depend on the device containing <code>_EDL</code> .
<code>_EJD</code>	Object that evaluates to the name of a device object on which a device depends. Whenever the named device is ejected, the dependent device must receive an ejection notification.
<code>_EJx</code>	Control method that ejects a device.
<code>_LCK</code>	Control method that locks or unlocks a device.
<code>_OST</code>	Control method invoked by OSPM to convey processing status to the platform.
<code>_RMV</code>	Object that indicates that the given device is removable.
<code>_STA</code>	Control method that returns a device's status.

6.3.1 `_EDL` (Eject Device List)

This object evaluates to a package of namespace references containing the names of device objects that depend on the device under which the `_EDL` object is declared. This is primarily used to support docking stations. Before the device under which the `_EDL` object is declared may be ejected, OSPM prepares the devices listed in the `_EDL` object for physical removal.

Arguments:

None

Return Value:

A variable-length **Package** containing a list of namespace references

Before OSPM ejects a device via the device's `_EJx` methods, all dependent devices listed in the package returned by `_EDL` are prepared for removal. Notice that `_EJx` methods under the dependent devices are not executed.

When describing a platform that includes a docking station, an `_EDL` object is declared under the docking station device. For example, if a mobile system can attach to two different types of docking stations, `_EDL` is declared under

both docking station devices and evaluates to the packaged list of devices that must be ejected when the system is ejected from the docking station.

An ACPI-compliant OS evaluates the `_EDL` method just prior to ejecting the device.

6.3.2 `_EJD` (Ejection Dependent Device)

This object is used to specify the name of a device on which the device, under which this object is declared, is dependent. This object is primarily used to support docking stations. Before the device indicated by `_EJD` is ejected, OSPM will prepare the dependent device (in other words, the device under which this object is declared) for removal.

Arguments:

None

Return Value:

A **String** containing the device name

`_EJD` is evaluated once when the ACPI table loads. The `EJx` methods of the device indicated by `_EJD` will be used to eject all the dependent devices. A device's dependents will be ejected when the device itself is ejected.

Note: OSPM will not execute a dependent device's `_EJx` methods when the device indicated by `_EJD` is ejected.

When describing a platform that includes a docking station, usually more than one `_EJD` object will be needed. For example, if a dock attaches both a PCI device and an ACPI-configured device to a mobile system, then both the PCI device description package and the ACPI-configured device description package must include an `_EJD` object that evaluates to the name of the docking station (the name specified in an `_ADR` or `_HID` object in the docking station's description package). Thus, when the docking connector signals an eject request, OSPM first attempts to disable and unload the drivers for both the PCI and ACPI configured devices.

Note: An ACPI 1.0 OS evaluates the `_EJD` methods only once during the table load process. This greatly restricts a table designer's freedom to describe dynamic dependencies such as those created in scenarios with multiple docking stations. This restriction is illustrated in the example below; the `_EJD` information supplied via an ACPI 1.0-compatible namespace omits the IDE2 device from DOCK2's list of ejection dependencies. Starting in ACPI 2.0, OSPM is presented with a more in-depth view of the ejection dependencies in a system by use of the `_EDL` methods.

Example

An example use of `_EJD` and `_EDL` is as follows:

```
Scope (\_SB.PCI0) {
    Device(DOCK1) { // Pass through dock - DOCK1
        Name(_ADR, ...)
        Method(_EJ0, 0) {...}
        Method(_DCK, 1) {...}
        Name(_BDN, ...)
        Method(_STA, 0) {0xF}
        Name(_EDL, Package() { // DOCK1 has two dependent devices - IDE2 and CB2
            \\_SB.PCI0.IDE2,
            \\_SB.PCI0.CB2})
        }
    Device(DOCK2) { // Pass through dock - DOCK2
        Name(_ADR, ...)
        Method(_EJ0, 0) {...}
    }
}
```

(continues on next page)

(continued from previous page)

```

Method(_DCK, 1) {...}
Name(_BDN, ...)
Method(_STA, 0) {0x0}
Name(_EDL, Package( ) { // DOCK2 has one dependent device - IDE2
  \_SB.PCI0.IDE2})
}
Device(IDE1) { // IDE Drive1 not dependent on the dock
  Name(_ADR, ...)
}
Device(IDE2) { // IDE Drive2
  Name(_ADR, ...)
  Name(_EJD, "\_SB.PCI0.DOCK1") // Dependent on DOCK1
}
Device(CB2) { // CardBus Controller
  Name(_ADR, ...)
  Name(_EJD, "\_SB.PCI0.DOCK1") // Dependent on DOCK1
}
} // end \_SB.PCI0

```

6.3.3 _EJx (Eject)

These control methods are optional and are supplied for devices that support a software-controlled VCR-style ejection mechanism or that require an action be performed such as isolation of power/data lines before the device can be removed from the system. To support warm (system is in a sleep state) and hot (system is in S0) removal, an _EJx control method is listed for each sleep state from which the device supports removal, where x is the sleeping state supported. For example, _EJ0 indicates the device supports hot removal; _EJ1-EJ4 indicate the device supports warm removal.

Arguments: (1)

- Arg0 - An Integer containing a device ejection control
- 0 - Cancel a mark for ejection request (EJ0 will never be called with this value)
- 1 - Hot eject or mark for ejection

Return Value:

None

For hot removal, the device must be immediately ejected when OSPM calls the _EJ0 control method. The _EJ0 control method does not return until ejection is complete. After calling _EJ0, OSPM verifies the device no longer exists to determine if the eject succeeded. For _HID devices, OSPM evaluates the _STA method. For _ADR devices, OSPM checks with the bus driver for that device.

For warm removal, the _EJ1-_EJ4 control methods do not cause the device to be immediately ejected. Instead, they set proprietary registers to prepare the hardware to eject when the system goes into the given sleep state. The hardware ejects the device only after OSPM has put the system in a sleep state by writing to the SLP_EN register. After the system resumes, OSPM calls _STA to determine if the eject succeeded.

A device object may have multiple _EJx control methods. First, it lists an EJx control method for the preferred sleeping state to eject the device. Optionally, the device may list an EJ4 control method to be used when the system has no power (for example, no battery) after the eject. For example, a hot-docking notebook might list _EJ0 and _EJ4.

6.3.4 _LCK (Lock)

This control method is optional and is required only for a device that supports a software-controlled locking mechanism. When the OS invokes this control method, the associated device is to be locked or unlocked based upon the value of the argument that is passed. On a lock request, the control method must not complete until the device is completely locked.

Arguments:

- Arg0 - An Integer containing a device lock control
- 0 - Unlock the device
- 1 - Lock the device

Return Value:

None

When describing a platform, devices use either a _LCK control method or an _EJx control method for a device.

6.3.5 _OST (OSPM Status Indication)

This object is an optional control method that is invoked by OSPM to indicate processing status to the platform. During device ejection, device hot add, Error Disconnect Recover, or other event processing, OSPM may need to perform specific handshaking with the platform. OSPM may also need to indicate to the platform its inability to complete a requested operation; for example, when a user presses an ejection button for a device that is currently in use or is otherwise currently incapable of being ejected. In this case, the processing of the ACPI **Eject Request** notification by OSPM fails. OSPM may indicate this failure to the platform through the invocation of the _OST control method. As a result of the status notification indicating ejection failure, the platform may take certain action including reissuing the notification or perhaps turning on an appropriate indicator light to signal the failure to the user.

Arguments: (3)

- Arg0 - An **Integer** containing the source event
- Arg1 - An **Integer** containing the status code
- Arg2 - A **Buffer** containing status information

Return Value:

None

Argument Information:

Arg0 - source_event: DWordConst

If the value of *source_event* is $\leq 0xFF$, this argument is the ACPI notification value whose processing generated the status indication. This is the value that was passed into the **Notify** operator.

If the value of *source_event* is $0x100$ or greater then the OSPM status indication is a result of an OSPM action as indicated in *OST Source Event Codes*. For example, a value of $0x103$ will be passed into _OST for this argument upon the failure of a user interface invoked device ejection.

If OSPM is unable to identify the originating notification value, OSPM invokes _OST with a value that contains all bits set (ones) for this parameter.

Arg1 – Status Code: DWordConst. OSPM indicates a notification value specific status. See [Table 6.22](#), [Table 6.23](#), and [Table 6.25](#) for status code descriptions.

Arg2 - A buffer containing detailed OSPM-specific information about the status indication. This argument may be null.

Table 6.21: OST Source Event Codes

Source Event Code	Description
0-0xFF	Reserved for Notification Values
0x100	Operation System Shutdown Processing
0x101-0x102	<i>Reserved</i>
0x103	Ejection Processing
0x104-0x1FF	<i>Reserved</i>
0x200	Insertion Processing
0x201-0xFFFFFFFF	<i>Reserved</i>

Table 6.22: General Processing Status Codes

Status Code	Description
0	Success
1	Non-specific failure
2	Unrecognized Notify Code
3-0x7F	<i>Reserved</i>
0x80-0xFFFFFFFF	Notification value specific status codes

Table 6.23: Operating System Shutdown Processing (Source Events : 0x100) Status Codes

Status Code	Description
0x80	OS Shutdown Request denied
0x81	OS Shutdown in progress
0x82	OS Shutdown completed
0x83	OS Graceful Shutdown not supported
0x84-0xFFFFFFFF	<i>Reserved</i>

6.3.5.1 Processing Sequence for Graceful Shutdown Request:

Following receipt of the Graceful Shutdown Request (see Table 5.188, value 0x81), the OS will be responsible for responding with one of the following status codes:

- 0x80 (OS Shutdown Request denied) - This value will be sent if the OS is not capable of performing a graceful shutdown.
- 0x81 (OS Shutdown in progress) - The OS has initiated the graceful shutdown procedure.
- 0x83 (OS Graceful Shutdown not supported) - The OS does not support the Graceful Shutdown Request.

If the OS does initiate a graceful shutdown it should continue to generate the “OS Shutdown in progress” message (_OST source event 0x100 status code 0x81) every 10 seconds. This functions as a heartbeat so that the service which requested the graceful shutdown knows that the request is currently being processed. The platform should assume that the OS shutdown is not proceeding if it does not receive the “OS Shutdown in progress” message for 60 seconds.

When the graceful shutdown procedure has completed the OSPM will send the “OS Shutdown completed” message and then transition the platform to the G2 “soft-off” power state.

Table 6.24: Ejection Request / Ejection Processing (Source Events: 0x03 and 0x103) Status Codes

Status Code	Description
0x80	Device ejection not supported by OSPM
0x81	Device in use by application
0x82	Device Busy
0x83	Ejection dependency is busy or not supported for ejection by OSPM
0x84	Ejection is in progress (pending)
0x85-0xFFFFFFFF	<i>Reserved</i>

Table 6.25: Insertion Processing (Source Event: 0x200) Status Codes

Status Code	Description
0x80	Device insertion in progress (pending)
0x81	Device driver load failure
0x82	Device insertion not supported by OSPM
0x83-0x8F	<i>Reserved</i>
0x90-0x9F	Insertion failure - Resources Unavailable as described by the following bit encodings: Bit [3] Bus or Segment Numbers Bit [2] Interrupts Bit [1] I/O Bit [0] Memory
0xA0-0xFFFFFFFF	<i>Reserved</i>

It is possible for the platform to issue multiple notifications to OSPM and for OSPM to process the notifications asynchronously. As such, OSPM may invoke _OST for notifications independent of the order the notification are conveyed by the platform or by software to OSPM.

The figure below provides an example event flow of device ejection on a platform employing the `_OST` object.

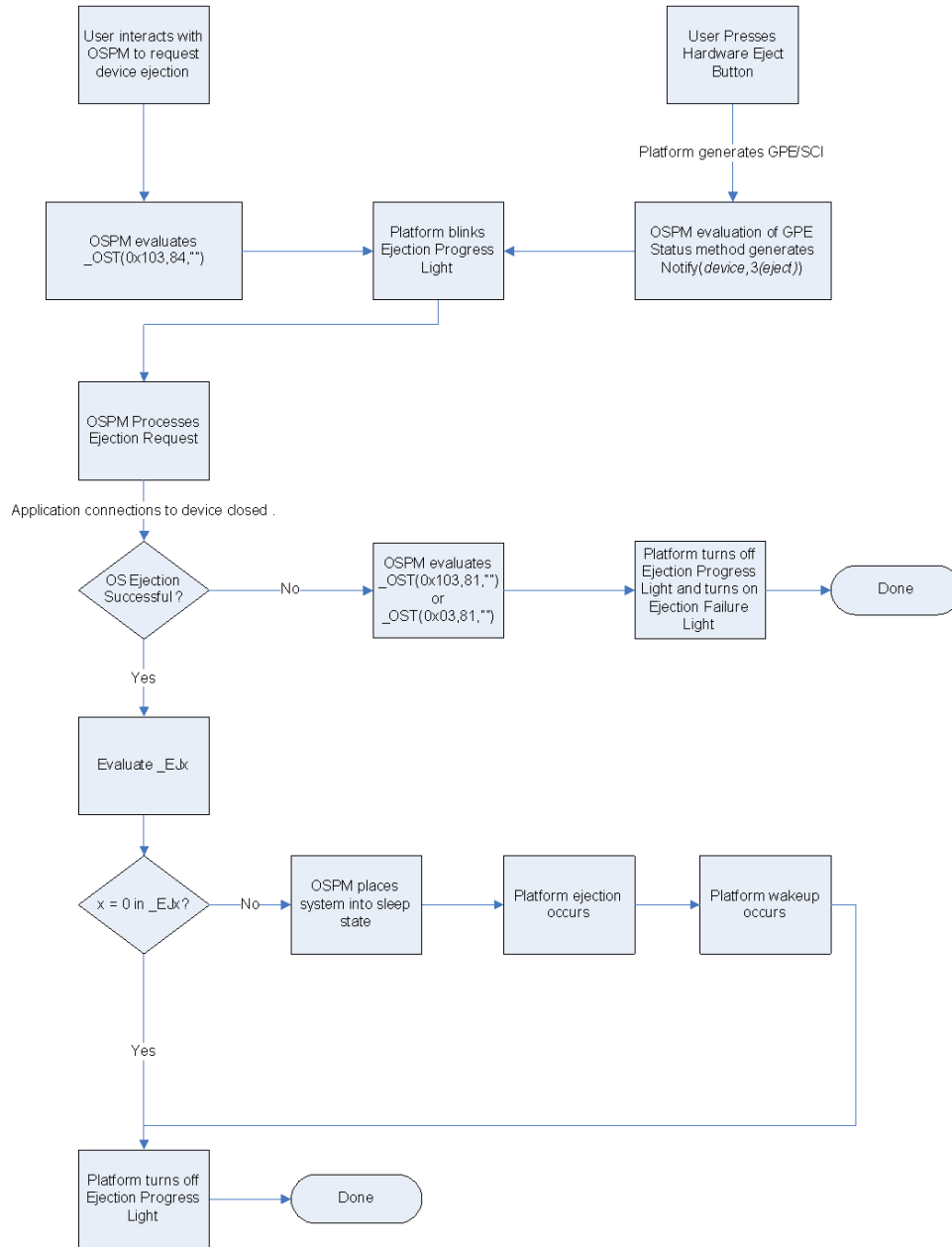

Fig. 6.6: Device Ejection Flow Example Using `_OST`

Note: To maintain compatibility with OSPM implementations of previous revisions of the ACPI specification, the platform must not rely on OSPM's evaluation of the `_OST` object for proper platform operation.

Example ASL for _OST usage:

```

External (\_SB.PCI4, DeviceObj)
Scope (\_SB.PCI4) {
    OperationRegion(LED1, SystemIO, 0x10C0, 0x20)
    Field(LED1, AnyAcc, NoLock, Preserve)
    {
        // LED controls
        S0LE, 1,           // Slot 0 Ejection Progress LED
        S0LF, 1,           // Slot 0 Ejection Failure LED
        S1LE, 1,           // Slot 1 Ejection Progress LED
        S1LF, 1,           // Slot 1 Ejection Failure LED
        S2LE, 1,           // Slot 2 Ejection Progress LED
        S2LF, 1,           // Slot 2 Ejection Failure LED
        S3LE, 1,           // Slot 3 Ejection Progress LED
        S3LF, 1           // Slot 3 Ejection Failure LED
    }
    Device(SLT3) { // hot plug device
        Name(_ADR, 0x000C0003)
        Method(_OST, 3, Serialized) { // OS calls _OST with notify code 3 or 0x103
            // and status codes 0x80-0x83
            // to indicate a hot remove request failure.
            // to indicate a hot remove request failure.
            // Status code 0x84 indicates an ejection
            // request pending.
            If(LEqual(Arg0, Ones)) // Unspecified event
            {
                // Perform generic event processing here
            }
            Switch(And(Arg0, 0xFF)) // Mask to retain low byte
            {
                Case(0x03) // Ejection request
                {
                    Switch(Arg1)
                    {
                        Case(Package() {0x80, 0x81, 0x82, 0x83})
                        {
                            // Ejection Failure for some reason
                            Store(Zero, ^^S3LE) // Turn off Ejection Progress LED
                            Store(One, ^^S3LF) // Turn on Ejection Failure LED
                        }
                        Case(0x84) // Eject request pending
                        {
                            Store(One, ^^S3LE) // Turn on Ejection Request LED
                            Store(Zero, ^^S3LF) // Turn off Ejection Failure LED
                        }
                    }
                }
            }
        } // end _OST
        Method(_EJ0, 1) // Successful ejection sequence
        {
            Store(Zero, ^^S3LE) // Turn off Ejection Progress LED
        }
    } // end SLT3
} // end scope \_SB.PCI4
Scope (\_GPE)
{
    Method(_E13)
    {

```

(continues on next page)

(continued from previous page)

```

Store(One, \\_SB.PCI4.S3LE) // Turn on ejection request LED
Notify(\\_SB.PCI4.SLT3, 3) // Ejection request driven from GPE13
}
}

```

6.3.5.2 Processing Sequence for Error Disconnect Recover

If the OS attempts recovery operation following the receipt of the Error Disconnect Recover Request (see *IPMI Status Codes*, value 0x0F) the OS will be responsible for invoking `_OST` with one of the following status codes in the lower word of `Arg1`:

- 0x80 (Success) - This value will be sent if the OS successfully recovers all the child devices affected by Error Disconnect Recover, reconfigures them and brings them back to functional state. All child devices are accessible at the time `_OST` is evaluated.
- 0x81 (Not recovered) - The OS did not successfully recover one or more child devices that were affected by Error Disconnect Recover. Access to the child devices affected by Error Disconnect Recover may be unreliable.

The upper word of `Arg1` can be used to communicate bus-specific status information.

6.3.6 `_RMV` (Remove)

The optional `_RMV` object indicates to OSPM whether the device can be removed while the system is in the working state and does not require any ACPI system firmware actions to be performed for the device to be safely removed from the system (in other words, any device that only supports surprise-style removal). Any such removable device that does not have `_LCK` or `_EJx` control methods must have an `_RMV` object. This allows OSPM to indicate to the user that the device can be removed and to provide a way for shutting down the device before removing it. OSPM will transition the device into D3 before telling the user it is safe to remove the device.

This method is reevaluated after a device-check notification.

Arguments:

None

Return Value:

An Integer containing the device removal status:

```

0 - The device cannot be removed
1 - The device can be removed

```

Note: Operating Systems implementing ACPI 1.0 interpret the presence of this object to mean that the device is removable.

6.3.7 `_STA` (Device Status)

This object returns the current status of a device, which can be one of the following: enabled, disabled, or removed.

OSPM evaluates the `_STA` object before it evaluates a device `_INI` method. The return values of the Present and Functioning bits determines whether `_INI` should be evaluated and whether children of the device should be enumerated and initialized. See `_INI (Init)`. If `_INI` is not present within the scope of a Device, it is unspecified whether `_STA` is evaluated prior to other objects within the Device scope.

Evaluation of `_STA` must not cause any change to platform context - it should be viewed as a “read only” operation.

If a device object describes a device that is not on an enumerable bus and the device object does not have an `_STA` object, then OSPM assumes that the device is present, enabled, shown in the UI, and functioning.

This method must not reference any operation regions that have not been declared available by a `_REG` method.

Arguments:

None

Return Value:

An **Integer** containing a device status bitmap:

- Bit [0] - Set if the device is present.
- Bit [1] - Set if the device is enabled and decoding its resources.
- Bit [2] - Set if the device should be shown in the UI.
- Bit [3] - Set if the device is functioning properly (cleared if device failed its diagnostics).
- Bit [4] - Set if the battery is present.
- Bits [31:5] - Reserved (must be cleared).

Return Value Information

If bit [0] is cleared, then bit 1 must also be cleared (in other words, a device that is not present cannot be enabled).

A device can only decode its hardware resources if both bits 0 and 1 are set. If the device is not present (bit [0] cleared) or not enabled (bit [1] cleared), then the device must not decode its resources.

If a device is present in the machine, but should not be displayed in OSPM user interface, bit 2 is cleared. For example, a notebook could have joystick hardware (thus it is present and decoding its resources), but the connector for plugging in the joystick requires a port replicator. If the port replicator is not plugged in, the joystick should not appear in the UI, so bit [2] is cleared.

`_STA` may return bit 0 clear (not present) with bit [3] set (device is functional). This case is used to indicate a valid device for which no device driver should be loaded (for example, a bridge device.) Children of this device may be present and valid. OSPM should continue enumeration below a device whose `_STA` returns this bit combination.

Bit [4] of `_STA` applies only to the Control Method Battery Device (PNP0C0A). For all other devices, OSPM must ignore this bit.

If a device object (including the processor object) does not have an `_STA` object, then OSPM assumes that all of the above bits are set (i.e., the device is present, enabled, shown in the UI, and functioning).

If a device is present on an enumerable bus, then `_STA` must not return 0. In that case, bit[0] must be set and if the status of the device can be determined through a bus-specific enumeration and discovery mechanism, it must be reflected by the values of bit[1] and bit[3], even though the OSPM is not required to take them into account.

6.4 Resource Data Types for ACPI

The `_CRS`, `_PRS`, and `_SRS` control methods use packages of resource descriptors to describe the resource requirements of devices.

6.4.1 ASL Macros for Resource Descriptors

ASL includes some macros for creating resource descriptors. The ASL syntax for these macros is defined in *ASL Operator Reference*, along with the other ASL operators.

6.4.2 Small Resource Data Type

A small resource data type may be 2 to 8 bytes in size and adheres to the following format:

Table 6.26: **Small Resource Data Type Tag Bit Definitions**

Offset	Field Description
Byte 0	Tag Bit [7]: Type-0 (Small item) Tag Bits [6:3]: Small item name Tag Bits [2:0]: Length- <i>n</i> bytes
Bytes 1 to <i>n</i>	Data bytes (Length 0 - 7)

The following small information items are currently defined for Plug and Play devices:

Table 6.27: **Small Resource Items**

Small Item Name	Value
<i>Reserved</i>	0x00-0x03
IRQ Format Descriptor	0x04
DMA Format Descriptor	0x05
Start Dependent Functions Descriptor	0x06
End Dependent Functions Descriptor	0x07
I/O Port Descriptor	0x08
Fixed Location I/O Port Descriptor	0x09
Fixed DMA Descriptor	0x0A
<i>Reserved</i>	0x0B-0x0D
Vendor Defined Descriptor	0x0E
End Tag Descriptor	0x0F

6.4.2.1 IRQ Descriptor

Type 0, Small Item Name 0x4, Length = 2 or 3

The IRQ data structure indicates that the device uses an interrupt level and supplies a mask with bits set indicating the levels implemented in this device. For standard PC-AT implementation there are 15 possible interrupts so a two-byte field is used. This structure is repeated for each separate interrupt required.

Table 6.28: **IRQ Descriptor Definition**

Offset	Field Name
Byte 0	Value = 0x22 or 0x23 (0010001nB) - Type = 0, Small item name = 0x4, Length = 2 or 3
Byte 1	IRQ mask bits[7:0], <code>_INT</code> Bit [0] represents IRQ0, bit[1] is IRQ1, and so on.

continues on next page

Table 6.28 – continued from previous page

Offset	Field Name
Byte 2	IRQ mask bits[15:8], _INT Bit [0] represents IRQ8, bit[1] is IRQ9, and so on.
Byte 3	<p>IRQ Information. Each bit, when set, indicates this device is capable of driving a certain type of interrupt. (Optional—if not included then assume edge sensitive, high true interrupts.) These bits can be used both for reporting and setting IRQ resources. Note: This descriptor is meant for describing interrupts that are connected to PIC-compatible interrupt controllers, which can only be programmed for Active-High-Edge-Triggered or Active-Low-Level-Triggered interrupts. Any other combination is invalid. The Extended Interrupt Descriptor can be used to describe other combinations:</p> <p>Bit [7:6] Reserved (must be 0)</p> <p>Bit [5] Wake Capability, _WKC 0x0 = Not Wake Capable: This interrupt is not capable of waking the system. 0x1 = Wake Capable: This interrupt is capable of waking the system from a low-power idle state or a system sleep state.</p> <p>Bit [4] Interrupt Sharing, _SHR 0x0 = Exclusive: This interrupt is not shared with other devices. 0x1 = Shared: This interrupt is shared with other devices.</p> <p>Bit [3] Interrupt Polarity, _LL 0 Active-High - This interrupt is sampled when the signal is high, or true 1 Active-Low - This interrupt is sampled when the signal is low, or false.</p> <p>Bit [2:1] <i>Ignored</i></p> <p>Bit [0] Interrupt Mode, _HE 0 Level-Triggered - Interrupt is triggered in response to signal in a low state. 1 Edge-Triggered - Interrupt is triggered in response to a change in signal state from low to high.</p>

Note: Low true, level sensitive interrupts may be electrically shared, but the process of how this might work is beyond the scope of this specification.

Note: If byte 3 is not included, High true, edge sensitive, non-shareable is assumed.

See *IRQ (Interrupt Resource Descriptor Macro)* for a description of the ASL macros that create an IRQ descriptor.

6.4.2.2 DMA Descriptor

Type 0, Small Item Name 0x5, Length = 2

The DMA data structure indicates that the device uses a DMA channel and supplies a mask with bits set indicating the channels actually implemented in this device. This structure is repeated for each separate channel required.

Table 6.29: DMA Descriptor Definition

Offset	Field Name
Byte 0	Value = 0x2A (00101010B) - Type = 0, Small item name = 0x5, Length = 2
Byte 1	DMA channel mask bits [7:0] (channels 0 - 7), _DMA - Bit [0] is channel 0, etc.

continues on next page

Table 6.29 – continued from previous page

Byte 2	<p>Bit [7] Reserved (must be 0)</p> <p>Bits [6:5] DMA channel speed supported, <i>_TYP</i>:</p> <p>00 Indicates compatibility mode</p> <p>01 Indicates Type A DMA as described in the EISA</p> <p>10 Indicates Type B DMA</p> <p>11 Indicates Type F</p> <p>Bits [4:3] <i>Ignored</i></p> <p>Bit [2] Logical device bus master status, <i>_BM</i>:</p> <p>0 Logical device is not a bus master</p> <p>1 Logical device is a bus master</p> <p>Bits [1:0] DMA transfer type preference, <i>_SIZ</i>:</p> <p>00 8-bit only</p> <p>01 8- and 16-bit</p> <p>10 16-bit only</p> <p>11 <i>Reserved</i></p>
--------	--

See *DMA (DMA Resource Descriptor Macro)* for a description of the ASL macro that creates a DMA descriptor.

6.4.2.3 Start Dependent Functions Descriptor

Type 0, Small Item Name 0x6, Length = 0 or 1

Each logical device requires a set of resources. This set of resources may have interdependencies that need to be expressed to allow arbitration software to make resource allocation decisions about the logical device. Dependent functions are used to express these interdependencies. The data structure definitions for dependent functions are shown here. For a detailed description of the use of dependent functions refer to the next section.

Table 6.30: Start Dependent Functions Descriptor Definition

Offset	Field Name
Byte 0	<p>Value = 0x30 or 0x31 (0011000nB)</p> <p>Type = 0, small item name = 0x6</p> <p>Length = 0 or 1</p>

Start Dependent Function fields may be of length 0 or 1 bytes. The extra byte is optionally used to denote the compatibility or performance/robustness priority for the resource group following the Start DF tag. The compatibility priority is a ranking of configurations for compatibility with legacy operating systems. This is the same as the priority used in the PNPBIOS interface. For example, for compatibility reasons, the preferred configuration for COM1 is IRQ4, I/O 3F8-3FF. The performance/robustness performance is a ranking of configurations for performance and robustness reasons. For example, a device may have a high-performance, bus mastering configuration that may not be supported by legacy operating systems. The bus-mastering configuration would have the highest performance/robustness priority while its polled I/O mode might have the highest compatibility priority.

If the Priority byte is not included, this indicates the dependent function priority is ‘acceptable’. This byte is defined as:

Table 6.31: Start Dependent Function Priority Byte Definition

Bits	Definition
1:0	Compatibility priority. Acceptable values are: 0 Good configuration: Highest Priority and preferred configuration 1 Acceptable configuration: Lower Priority but acceptable configuration 2 Sub-optimal configuration: Functional configuration but not optimal 3 Reserved
3:2	Performance/robustness. Acceptable values are: 0 Good configuration: Highest Priority and preferred configuration 1 Acceptable configuration: Lower Priority but acceptable configuration 2 Sub-optimal configuration: Functional configuration but not optimal 3 Reserved
7:4	Reserved (must be 0)

Notice that if multiple Dependent Functions have the same priority, they are further prioritized by the order in which they appear in the resource data structure. The Dependent Function that appears earliest (nearest the beginning) in the structure has the highest priority, and so on.

See *StartDependentFn (Start Dependent Function Resource Descriptor Macro)* for a description of the ASL macro that creates a Start Dependent Function descriptor.

6.4.2.4 End Dependent Functions Descriptor

Type 0, Small Item Name 0x7, Length = 0

Only one End Dependent Function item is allowed per logical device. This enforces the fact that Dependent Functions cannot be nested.

Table 6.32: End Dependent Functions Descriptor Definition

Offset	Field Name
Byte 0	Value = 0x38 (00111000B) - Type = 0, Small item name = 0x7, Length =0

See *EndDependentFn (End Dependent Function Resource Descriptor Macro)* for a description of the ASL macro that creates an End Dependent Functions descriptor.

6.4.2.5 I/O Port Descriptor

Type 0, Small Item Name 0x8, Length = 7

There are two types of descriptors for I/O ranges. The first descriptor is a full function descriptor for programmable devices. The second descriptor is a minimal descriptor for old ISA cards with fixed I/O requirements that use a 10-bit ISA address decode. The first type descriptor can also be used to describe fixed I/O requirements for ISA cards that require a 16-bit address decode. This is accomplished by setting the range minimum base address and range maximum base address to the same fixed I/O value.

Table 6.33: I/O Port Descriptor Definition

Offset	Field Name	Definition
Byte 0	I/O Port Descriptor	Value = 0x47 (01000111B) - Type = 0, Small item name = 0x8, Length = 7
Byte 1	Information	Bits [7:1] Reserved and must be 0 Bit [0] (_DEC) 1 The logical device decodes 16-bit addresses 0 The logical device only decodes address bits[9:0]
Byte 2	Range minimum base address, _MIN bits[7:0]	Address bits [7:0] of the minimum base I/O address that the card may be configured for.
Byte 3	Range minimum base address, _MIN bits[15:8]	Address bits [15:8] of the minimum base I/O address that the card may be configured for.
Byte 4	Range maximum base address, _MAX bits[7:0]	Address bits [7:0] of the maximum base I/O address that the card may be configured for.
Byte 5	Range maximum base address, _MAX bits[15:8]	Address bits [15:8] of the maximum base I/O address that the card may be configured for.
Byte 6	Base alignment, _ALN	Alignment for minimum base address, increment in 1-byte blocks.
Byte 7	Range length, _LEN	The number of contiguous I/O ports requested.

See *IO (IO Resource Descriptor Macro)* for a description of the ASL macro that creates an I/O Port descriptor.

6.4.2.6 Fixed Location I/O Port Descriptor

Type 0, Small Item Name 0x9, Length = 3

This descriptor is used to describe 10-bit I/O locations.

Table 6.34: Fixed-Location I/O Port Descriptor Definition

Offset	Field Name	Definition
Byte 0	Fixed Location I/O Port Descriptor	Value = 0x4B (01001011B) - Type = 0, Small item name = 0x9, Length = 3
Byte 1	Range base address, _BAS bits[7:0]	Address bits [7:0] of the base I/O address that the card may be configured for. This descriptor assumes a 10-bit ISA address decode.
Byte 2	Range base address, _BAS bits[9:8]	Address bits [9:8] of the base I/O address that the card may be configured for. This descriptor assumes a 10-bit ISA address decode.
Byte 3	Range length, _LEN	The number of contiguous I/O ports requested.

See *FixedIO (Fixed IO Resource Descriptor Macro)* for a description of the ASL macro that creates a Fixed I/O Port descriptor.

6.4.2.7 Fixed DMA Descriptor

Type 0, Small Item Name 0xA, Length = 5

The Fixed DMA descriptor provides a means for platforms to statically assign DMA request lines and channels to devices connected to a shared DMA controller. This descriptor differs from the DMA descriptor in that it supports many more DMA request lines and DMA controller channels, as well as a flexible mapping between the two. The width of the bus used for transfers to the device is also provided. This structure is repeated for each separate request line/channel pair required, and can only be used in the `_CRS` object. (Dynamic arbitration of Fixed DMA resource is not supported.)

Table 6.35: Fixed DMA Resource Descriptor

Offset	Field Name
Byte 0	Value = 0x55 (01010101B) - Type = 0, Small item name = 0xA, Length = 0x5
Byte 1	DMA Request Line bits [7:0] <code>_DMA[7:0]</code> . A platform-relative number uniquely identifying the request line assigned. Request line-to-Controller mapping is done in a controller-specific OS driver.
Byte 2	DMA Request Line bits [15:8] <code>_DMA[15:8]</code>
Byte 3	DMA Channel bits[7:0] <code>_TYP[7:0]</code> . A controller-relative number uniquely identifying the controller's logical channel assigned. Channel numbers can be shared by multiple request lines.
Byte 4	DMA Channel bits[15:8] <code>_TYP[15:8]</code>
Byte 5	DMA Transfer Width. <code>_SIZ</code> . Bus width that the device connected to this request line supports. 0x00 8-bit 0x01 16-bit 0x02 32-bit 0x03 64-bit 0x04 128-bit 0x05 256-bit 0x06-0xFF Reserved

6.4.2.8 Vendor-Defined Descriptor, Type 0

Type 0, Small Item Name 0xE, Length = 1 to 7

The vendor defined resource data type is for vendor use.

Table 6.36: Vendor-Defined Resource Descriptor Definition

Offset	Field Name
Byte 0	Value = 0x71 - 0x77 (01110nnnB) - Type = 0, small item name = 0xE, Length = 1-7
Byte 1 to 7	Vendor defined

See *VendorShort (Short Vendor Resource Descriptor)* for a description of the ASL macro that creates a short vendor-defined resource descriptor.

6.4.2.9 End Tag

Type 0, Small Item Name 0xF, Length = 1

The End tag identifies an end of resource data.

Note: If the checksum field is zero, the resource data is treated as if the checksum operation succeeded. Configuration proceeds normally.

Table 6.37: End Tag Definition

Offset	Field Name
Byte 0	Value = 0x79 (01111001B) - Type = 0, Small item name = 0xF, Length = 1
Byte 1	Checksum covering all resource data after the serial identifier. This checksum is generated such that adding it to the sum of all the data bytes will produce a zero sum.

The End Tag is automatically generated by the ASL compiler at the end of the ResourceTemplate statement.

6.4.3 Large Resource Data Type

To allow for larger amounts of data to be included in the configuration data structure the large format is shown below. This includes a 16-bit length field allowing up to 64 KB of data.

Table 6.38: Large Resource Data Type Tag Bit Definitions

Offset	Field Name
Byte 0	Value = 1xxxxxxB Type = 1 (Large item) Large item name = xxxxxxxB
Byte 1	Length of data items bits[7:0]
Byte 2	Length of data items bits[15:8]
Bytes 3 to (Length + 2)	Actual data items

The following large information items are currently defined:

Table 6.39: Large Resource Items

Large Item Name	Value
<i>Reserved</i>	0x00
24-Bit Memory Range Descriptor	0x01
Generic Register Descriptor	0x02
<i>Reserved</i>	0x03
Vendor-Defined Descriptor	0x04
32-Bit Memory Range Descriptor	0x05
32-Bit Fixed Memory Range Descriptor	0x06
Address Space Resource Descriptors	0x07
Word Address Space Descriptor	0x08
Extended Interrupt Descriptor	0x09
QWord Address Space Descriptor	0x0A
Extended Address Space Descriptor	0x0B
GPIO Connection Descriptor	0x0C
Pin Function Descriptor	0x0D
GenericSerialBus Connection Descriptors	0x0E
Pin Configuration Descriptor	0x0F
Pin Group Descriptor	0x10
Pin Group Function Descriptor	0x11
Pin Group Configuration Descriptor	0x12
Clock Input Resource Descriptor	0x13
<i>Reserved</i>	0x14-0x7F

6.4.3.1 24-Bit Memory Range Descriptor

Type 1, Large Item Value 0x1

The 24-bit memory range descriptor describes a device's memory range resources within a 24-bit address space

Table 6.40: 24-bit Memory Range Descriptor Definition

Offset	Field Name, ASL Field Name	Definition
Byte 0	24-bit Memory Range Descriptor	Value = 0x81 (10000001B) - Type = 1, Large item name = 0x01
Byte 1	Length, bits[7:0]	Value = 0x09 (9)
Byte 2	Length, bits[15:8]	Value = 0x00
Byte 3	Information	This field provides extra information about this memory: Bit [7:1] <i>Ignored</i> Bit [0] Write status, <i>_RW</i> : 1 writeable (read/write) 0 non-writeable (read-only)
Byte 4	Range minimum base address, <i>_MIN</i> , bits[7:0]	Address bits [15:8] of the minimum base memory address for which the card may be configured.
Byte 5	Range minimum base address, <i>_MIN</i> , bits[15:8]	Address bits [23:16] of the minimum base memory address for which the card may be configured
Byte 6	Range maximum base address, <i>_MAX</i> , bits[7:0]	Address bits [15:8] of the maximum base memory address for which the card may be configured.
Byte 7	Range maximum base address, <i>_MAX</i> , bits[15:8]	Address bits [23:16] of the maximum base memory address for which the card may be configured
Byte 8	Base alignment, <i>_ALN</i> , bits[7:0]	This field contains the lower eight bits of the base alignment. The base alignment provides the increment for the minimum base address. (0x0000 = 64 KB)
Byte 9	Base alignment, <i>_ALN</i> , bits[15:8]	This field contains the upper eight bits of the base alignment. The base alignment provides the increment for the minimum base address. (0x0000 = 64 KB)
Byte 10	Range length, <i>_LEN</i> , bits[7:0]	This field contains the lower eight bits of the memory range length. The range length provides the length of the memory range in 256 byte blocks.
Byte 11	Range length, <i>_LEN</i> , bits[15:8]	This field contains the upper eight bits of the memory range length. The range length field provides the length of the memory range in 256 byte blocks.

Note: Address bits [7:0] of memory base addresses are assumed to be 0.

Note: A Memory range descriptor can be used to describe a fixed memory address by setting the range minimum base address and the range maximum base address to the same value.

Note: 24-bit Memory Range descriptors are used for legacy devices.

Note: Mixing of 24-bit and 32-bit memory descriptors on the same device is not allowed.

See *Memory24 (Memory Resource Descriptor Macro)* for a description of the ASL macro that creates a 24-bit Memory descriptor.

6.4.3.2 Vendor-Defined Descriptor, Type 1

Type 1, Large Item Value 0x4

The vendor defined resource data type is for vendor use.

Table 6.41: **Large Vendor-Defined Resource Descriptor Definition**

Offset	Field Name	Definition
Byte 0	Vendor Defined Descriptor	Value = 0x84 (10000100B) - Type = 1, Large item name = 0x04
Byte 1	Length, bits [7:0]	Lower eight bits of data length (UUID and vendor data)
Byte 2	Length, bits [15:8]	Upper eight bits of data length (UUID and vendor data)
Byte 3	UUID specific descriptor sub type	UUID specific descriptor sub type value
Byte 4-19	UUID	UUID Value
Byte 20- (Length+20)	Vendor Defined Data	Vendor defined data bytes

This specification (ACPI) defines the UUID specific descriptor subtype field and the UUID field to address potential collision of the use of this descriptor. It is strongly recommended that all newly defined vendor descriptors use these fields prior to Vendor Defined Data.

See *VendorLong* for a description of the ASL macro that creates a long vendor-defined resource descriptor.

6.4.3.3 32-Bit Memory Range Descriptor

Type 1, Large Item Value 0x5

This memory range descriptor describes a device's memory resources within a 32-bit address space.

Table 6.42: **32-Bit Memory Range Descriptor Definition**

Offset	Field Name	Definition
Byte 0	32-bit Memory Range Descriptor	Value = 0x85 (10000101B) - Type = 1, Large item name = 0x05
Byte 1	Length, bits [7:0]	Value = 0x11 (17)
Byte 2	Length, bits [15:8]	Value = 0x00
Byte 3	Information	This field provides extra information about this memory: Bit [7:1] <i>Ignored</i> Bit [0] Write status, <i>_RW</i> : 1 writeable (read/write) 0 non-writeable (read-only)

continues on next page

Table 6.42 – continued from previous page

Byte 4	Range minimum base address, <code>_MIN</code> , bits [7:0]	Address bits [7:0] of the minimum base memory address for which the card may be configured.
Byte 5	Range minimum base address, <code>_MIN</code> , bits [15:8]	Address bits [15:8] of the minimum base memory address for which the card may be configured.
Byte 6	Range minimum base address, <code>_MIN</code> , bits [23:16]	Address bits [23:16] of the minimum base memory address for which the card may be configured.
Byte 7	Range minimum base address, <code>_MIN</code> , bits [31:24]	Address bits [31:24] of the minimum base memory address for which the card may be configured.
Byte 8	Range maximum base address, <code>_MAX</code> , bits [7:0]	Address bits [7:0] of the maximum base memory address for which the card may be configured.
Byte 9	Range maximum base address, <code>_MAX</code> , bits [15:8]	Address bits [15:8] of the maximum base memory address for which the card may be configured.
Byte 10	Range maximum base address, <code>_MAX</code> , bits [23:16]	Address bits [23:16] of the maximum base memory address for which the card may be configured.
Byte 11	Range maximum base address, <code>_MAX</code> , bits [31:24]	Address bits [31:24] of the maximum base memory address for which the card may be configured.
Byte 12	Base alignment, <code>_ALN</code> bits [7:0]	This field contains bits [7:0] of the base alignment. The base alignment provides the increment for the minimum base address.
Byte 13	Base alignment, <code>_ALN</code> bits [15:8]	This field contains bits [15:8] of the base alignment. The base alignment provides the increment for the minimum base address.
Byte 14	Base alignment, <code>_ALN</code> bits [23:16]	This field contains bits [23:16] of the base alignment. The base alignment provides the increment for the minimum base address.
Byte 15	Base alignment, <code>_ALN</code> bits [31:24]	This field contains bits [31:24] of the base alignment. The base alignment provides the increment for the minimum base address.
Byte 16	Range length, <code>_LEN</code> bits [7:0]	This field contains bits [7:0] of the memory range length. The range length provides the length of the memory range in 1-byte blocks.
Byte 17	Range length, <code>_LEN</code> bits [15:8]	This field contains bits [15:8] of the memory range length. The range length provides the length of the memory range in 1-byte blocks.
Byte 18	Range length, <code>_LEN</code> bits [23:16]	This field contains Bits [23:16] of the memory range length. The range length provides the length of the memory range in 1-byte blocks.
Byte 19	Range length, <code>_LEN</code> bits [31:24]	This field contains Bits [31:24] of the memory range length. The range length provides the length of the memory range in 1-byte blocks.

Note: Mixing of 24-bit and 32-bit memory descriptors on the same device is not allowed.

See *Memory32 (Memory Resource Descriptor Macro)* for a description of the ASL macro that creates a 32-bit Memory descriptor.

6.4.3.4 32-Bit Fixed Memory Range Descriptor

Type 1, Large Item Value 0x6

This memory range descriptor describes a device's memory resources within a 32-bit address space.

Table 6.43: 32-bit Fixed-Location Memory Range Descriptor Definition

Offset	Field Name	Definition
Byte 0	32-bit Fixed Memory Range Descriptor	Value = 0x86 (10000110B) - Type = 1, Large item name = 0x06
Byte 1	Length, bits [7:0]	Value = 0x09 (9)
Byte 2	Length, bits [15:8]	Value = 0x00
Byte 3	Information	This field provides extra information about this memory. Bit [7:1] <i>Ignored</i> Bit [0] Write status, <i>_RW</i> 1 writeable (read/write) 0 non-writeable (read-only))
Byte 4	Range base address, <i>_BAS</i> bits [7:0]	Address bits [7:0] of the base memory address for which the card may be configured.
Byte 5	Range base address, <i>_BAS</i> bits [15:8]	Address bits [15:8] of the base memory address for which the card may be configured.
Byte 6	Range base address, <i>_BAS</i> bits [23:16]	Address bits [23:16] of the base memory address for which the card may be configured.
Byte 7	Range base address, <i>_BAS</i> bits [31:24]	Address bits [31:24] of the base memory address for which the card may be configured.
Byte 8	Range length, <i>_LEN</i> bits [7:0]	This field contains bits [7:0] of the memory range length. The range length provides the length of the memory range in 1-byte blocks.
Byte 9	Range length, <i>_LEN</i> bits [15:8]	This field contains bits [15:8] of the memory range length. The range length provides the length of the memory range in 1-byte blocks.
Byte 10	Range length, <i>_LEN</i> bits [23:16]	This field contains bits [23:16] of the memory range length. The range length provides the length of the memory range in 1-byte blocks.
Byte 11	Range length, <i>_LEN</i> bits [31:24]	This field contains bits [31:24] of the memory range length. The range length provides the length of the memory range in 1-byte blocks.

Note: Mixing of 24-bit and 32-bit memory descriptors on the same device is not allowed.

See *Memory32Fixed (Memory Resource Descriptor Macro)* for a description of the ASL macro that creates a 32-bit Fixed Memory descriptor.

6.4.3.5 Address Space Resource Descriptors

The QWORD, DWORD, WORD, and Extended Address Space Descriptors are general-purpose structures for describing a variety of types of resources. These resources also include support for advanced server architectures (such as multiple root buses), and resource types found on some RISC processors. These descriptors can describe various kinds of resources. The following table defines the valid combination of each field and how they should be interpreted.

Table 6.44: Valid Combination of Address Space Descriptor Fields

<u>LEN</u>	<u>MIF</u>	<u>MAF</u>	Definition
0	0	0	Variable size, variable location resource descriptor for <u>PRS</u> . If <u>MIF</u> is set, <u>MIN</u> must be a multiple of (<u>GRA</u> +1). If <u>MAF</u> is set, <u>MAX</u> must be (a multiple of (<u>GRA</u> +1))-1. OS can pick the resource range that satisfies following conditions: If <u>MIF</u> is not set, start address is a multiple of (<u>GRA</u> +1) and greater or equal to <u>MIN</u> . Otherwise, start address is <u>MIN</u> . If <u>MAF</u> is not set, end address is (a multiple of (<u>GRA</u> +1))-1 and less or equal to <u>MAX</u> . Otherwise, end address is <u>MAX</u> .
0	0	1	Variable size, variable location resource descriptor for <u>PRS</u> . If <u>MIF</u> is set, <u>MIN</u> must be a multiple of (<u>GRA</u> +1). If <u>MAF</u> is set, <u>MAX</u> must be (a multiple of (<u>GRA</u> +1))-1. OS can pick the resource range that satisfies following conditions: If <u>MIF</u> is not set, start address is a multiple of (<u>GRA</u> +1) and greater or equal to <u>MIN</u> . Otherwise, start address is <u>MIN</u> . If <u>MAF</u> is not set, end address is (a multiple of (<u>GRA</u> +1))-1 and less or equal to <u>MAX</u> . Otherwise, end address is <u>MAX</u> .
0	1	0	Variable size, variable location resource descriptor for <u>PRS</u> . If <u>MIF</u> is set, <u>MIN</u> must be a multiple of (<u>GRA</u> +1). If <u>MAF</u> is set, <u>MAX</u> must be (a multiple of (<u>GRA</u> +1))-1. OS can pick the resource range that satisfies following conditions: If <u>MIF</u> is not set, start address is a multiple of (<u>GRA</u> +1) and greater or equal to <u>MIN</u> . Otherwise, start address is <u>MIN</u> . If <u>MAF</u> is not set, end address is (a multiple of (<u>GRA</u> +1))-1 and less or equal to <u>MAX</u> . Otherwise, end address is <u>MAX</u> .
0	1	1	(Invalid combination)
> 0	0	0	Fixed size, variable location resource descriptor for <u>PRS</u> . <u>LEN</u> must be a multiple of (<u>GRA</u> +1). OS can pick the resource range that satisfies following conditions: Start address is a multiple of (<u>GRA</u> +1) and greater or equal to <u>MIN</u> . End address is (start address+ <u>LEN</u> -1) and less or equal to <u>MAX</u> .
> 0	0	1	(Invalid combination)
> 0	1	0	(Invalid combination)
> 0	1	1	Fixed size, fixed location resource descriptor. <u>GRA</u> must be 0 and <u>LEN</u> must be (<u>MAX</u> - <u>MIN</u> + 1).

6.4.3.5.1 QWord Address Space Descriptor

Type 1, Large Item Value 0xA

The QWORD address space descriptor is used to report resource usage in a 64-bit address space (like memory and I/O).

Table 6.45: WORD Address Space Descriptor Definition

Offset	Field Name	Definition
Byte 0	QWORD Address Space Descriptor	Value = 0x8A (10001010B) - Type = 1, Large item name = 0x0A
Byte 1	Length, bits[7:0]	Variable length, minimum value = 0x2B (43)
Byte 2	Length, bits[15:8]	Variable length, minimum value = 0x00
Byte 3	Resource Type	Indicates which type of resource this descriptor describes. Defined values are: 0 Memory range 1 I/O range 2 Bus number range 3-191 Reserved 192-255 Hardware Vendor Defined
Byte 4	General Flags	<p>Flags that are common to all resource types:</p> <p>Bits [7:4] Reserved (must be 0)</p> <p>Bit [3] Max Address Fixed, _MAF:</p> <p> 1 The specified maximum address is fixed</p> <p> 0 The specified maximum address is not fixed and can be changed</p> <p>Bit [2] Min Address Fixed, _MIF:</p> <p> 1 The specified minimum address is fixed</p> <p> 0 The specified minimum address is not fixed and can be changed</p> <p>Bit [1] Decode Type, _DEC:</p> <p> 1 This bridge subtractively decodes this address (top level bridges only)</p> <p> 0 This bridge positively decodes this address Bit [0] Ignored</p>
Byte 5	Type Specific Flags	Flags that are specific to each resource type. The meaning of the flags in this field depends on the value of the Resource Type field (see above).
Byte 6	Address space granularity, _GRA bits[7:0]	A set bit in this mask means that this bit is decoded. All bits less significant than the most significant set bit must be set. That is, the value of the full Address Space Granularity field (all 64 bits) must be a number (2 ⁿ -1).
Byte 7	Address space granularity, _GRA bits[15:8]	
Byte 8	Address space granularity, _GRA bits[23:16]	
Byte 9	Address space granularity, _GRA bits[31:24]	
Byte 10	Address space granularity, _GRA bits[39:32]	
Byte 11	Address space granularity, _GRA bits[47:40]	
Byte 12	Address space granularity, _GRA bits[55:48]	
Byte 13	Address space granularity, _GRA bits[63:56]	
Byte 14	Address range minimum, _MIN bits[7:0]	For bridges that translate addresses, this is the address space on the secondary side of the bridge.

continues on next page

Table 6.45 – continued from previous page

Offset	Field Name	Definition
Byte 15	Address range minimum, _MIN bits[15:8]	
Byte 16	Address range minimum, _MIN bits[23:16]	
Byte 17	Address range minimum, _MIN bits[31:24]	
Byte 18	Address range minimum, _MIN bits[39:32]	
Byte 19	Address range minimum, _MIN bits[47:40]	
Byte 20	Address range minimum, _MIN bits[55:48]	
Byte 21	Address range minimum, _MIN bits[63:56]	
Byte 22	Address range maximum, _MAX bits[7:0]	For bridges that translate addresses, this is the address space on the secondary side of the bridge.
Byte 23	Address range maximum, _MAX bits[15:8]	
Byte 24	Address range maximum, _MAX bits[23:16]	
Byte 25	Address range maximum, _MAX bits[31:24]	
Byte 26	Address range maximum, _MAX bits[39:32]	For bridges that translate addresses, this is the address space on the secondary side of the bridge.
Byte 27	Address range maximum, _MAX bits[47:40]	
Byte 28	Address range maximum, _MAX bits[55:48]	
Byte 29	Address range maximum, _MAX bits[63:56]	
Byte 30	Address Translation offset, _TRA bits[7:0]	For bridges that translate addresses across the bridge, this is the offset that must be added to the address on the secondary side to obtain the address on the primary side. Non-bridge devices must list 0 for all Address Translation offset bits.
Byte 31	Address Translation offset, _TRA bits[15:8]	
Byte 32	Address Translation offset, _TRA bits[23:16]	
Byte 33	Address Translation offset, _TRA bits[31:24]	
Byte 34	Address Translation offset, _TRA bits[39:32]	
Byte 35	Address Translation offset, _TRA bits[47:40]	
Byte 36	Address Translation offset, _TRA bits[55:48]	
Byte 37	Address Translation offset, _TRA bits[63:56]	
Byte 38	Address length, _LEN bits[7:0]	

continues on next page

Table 6.45 – continued from previous page

Offset	Field Name	Definition
Byte 39	Address length, _LEN, bits[15:8]	
Byte 40	Address length, _LEN bits[23:16]	
Byte 41	Address length, _LEN bits[31:24]	
Byte 42	Address length, _LEN bits[39:32]	
Byte 43	Address length, _LEN bits[47:40]	
Byte 44	Address length, _LEN bits[55:48]	
Byte 45	Address length, _LEN bits[63:56]	
Byte 46	Resource Source Index	Reserved. If the platform specifies “Interrupt ResourceSource support” in bit 13 of <i>Platform-Wide _OSC Capabilities DWORD 2</i> , then this field must be zero.
String	Resource Source	(Optional) If present, the device that uses this descriptor consumes its resources from the resources produced by the named device object. If not present, the device consumes its resources out of a global pool.

See QWordIO, QWordMemory, and ASL_QWordAddressSpace for a description of the ASL macros that creates a QWORD Address Space descriptor.

6.4.3.5.2 DWord Address Space Descriptor

Type 1, Large Item Value 0x7

The DWORD address space descriptor is used to report resource usage in a 32-bit address space (like memory and I/O).

Table 6.46: **DWORD Address Space Descriptor Definition**

Offset	Field Name	Definition
Byte 0	DWORD Address Space Descriptor	Value = 0x87 (10000111B) - Type = 1, Large item name = 0x07
Byte 1	Length, bits [7:0]	Variable: Value = 23 (minimum)
Byte 2	Length, bits [15:8]	Variable: Value = 0 (minimum)
Byte 3	Resource Type	Indicates which type of resource this descriptor describes. Defined values are: 0 Memory range 1 I/O range 2 Bus number range 3-191 Reserved 192-255 Hardware Vendor Defined

continues on next page

Table 6.46 – continued from previous page

Byte 4	General Flags	<p>Flags that are common to all resource types:</p> <p>Bits [7:4] Reserved (must be 0)</p> <p>Bit [3] Max Address Fixed, <code>_MAF</code>:</p> <p> 1 The specified maximum address is fixed</p> <p> 0 The specified maximum address is not fixed and can be changed</p> <p>Bit [2] Min Address Fixed, <code>_MIF</code>:</p> <p> 1 The specified minimum address is fixed</p> <p> 0 The specified minimum address is not fixed and can be changed</p> <p>Bit [1] Decode Type, <code>_DEC</code>:</p> <p> 1 This bridge subtractively decodes this address (top level bridges only)</p> <p> 0 This bridge positively decodes this address</p> <p>Bit [0] Ignored</p>
Byte 5	Type Specific Flags	Flags that are specific to each resource type. The meaning of the flags in this field depends on the value of the Resource Type field (see above).
Byte 6	Address space granularity, <code>_GRA</code> bits[7:0]	A set bit in this mask means that this bit is decoded. All bits less significant than the most significant set bit must be set. (in other words, the value of the full Address Space Granularity field (all 32 bits) must be a number (2^n-1)).
Byte 7	Address space granularity, <code>_GRA</code> bits[15:8]	
Byte 8	Address space granularity, <code>_GRA</code> bits [23:16]	
Byte 9	Address space granularity, <code>_GRA</code> bits [31:24]	
Byte 10	Address range minimum, <code>_MIN</code> bits [7:0]	For bridges that translate addresses, this is the address space on the secondary side of the bridge.
Byte 11	Address range minimum, <code>_MIN</code> bits [15:8]	
Byte 12	Address range minimum, <code>_MIN</code> bits [23:16]	
Byte 13	Address range minimum, <code>_MIN</code> bits [31:24]	
Byte 14	Address range maximum, <code>_MAX</code> bits [7:0]	For bridges that translate addresses, this is the address space on the secondary side of the bridge.
Byte 15	Address range maximum, <code>_MAX</code> bits [15:8]	
Byte 16	Address range maximum, <code>_MAX</code> bits [23:16]	
Byte 17	Address range maximum, <code>_MAX</code> bits [31:24]	
Byte 18	Address Translation offset, <code>_TRA</code> bits [7:0]	For bridges that translate addresses across the bridge, this is the offset that must be added to the address on the secondary side to obtain the address on the primary side. Non-bridge devices must list 0 for all Address Translation offset bits.
Byte 19	Address Translation offset, <code>_TRA</code> bits [15:8]	

continues on next page

Table 6.46 – continued from previous page

Byte 20	Address Translation offset, <code>_TRA</code> bits [23:16]	
Byte 21	Address Translation offset, <code>_TRA</code> bits [31:24]	
Byte 22	Address Length, <code>_LEN</code> , bits [7:0]	
Byte 23	Address Length, <code>_LEN</code> , bits [15:8]	
Byte 24	Address Length, <code>_LEN</code> , bits [23:16]	
Byte 25	Address Length, <code>_LEN</code> , bits [31:24]	
Byte 26	Resource Source Index	(Optional) Only present if Resource Source (below) is present. This field gives an index to the specific resource descriptor that this device consumes from in the current resource template for the device object pointed to in Resource Source.
String	Resource Source	(Optional) If present, the device that uses this descriptor consumes its resources from the resources produced by the named device object. If not present, the device consumes its resources out of a global pool. If not present, the device consumes this resource from its hierarchical parent.

See `DWordIO`, `DWordMemory` and `ASL_DWordAddressSpace` for a description of the ASL macro that creates a `DWORD` Address Space descriptor

6.4.3.5.3 Word Address Space Descriptor

Type 1, Large Item Value 0x8

The `WORD` address space descriptor is used to report resource usage in a 16-bit address space (like memory and I/O).

Note: This descriptor is exactly the same as the `DWORD` descriptor specified in *End Dependent Functions Descriptor*; the only difference is that the address fields are 16 bits wide rather than 32 bits wide.

Table 6.47: **WORD** Address Space Descriptor Definition

Offset	Field Name	Definition
Byte 0	<code>WORD</code> Address Space Descriptor	Value = 0x88 (10001000B) - Type = 1, Large item name = 0x08
Byte 1	Length, bits [7:0]	Variable length, minimum value = 0x0D (13)
Byte 2	Length, bits [15:8]	Variable length, minimum value = 0x00
Byte 3	Resource Type	Indicates which type of resource this descriptor describes. Defined values are: 0 Memory range 1 I/O range 2 Bus number range 3-191 Reserved 192-255 Hardware Vendor Defined

continues on next page

Table 6.47 – continued from previous page

Offset	Field Name	Definition
Byte 4	General Flags	<p>Flags that are common to all resource types:</p> <p>Bit [3] Max Address Fixed, <i>_MAF</i>:</p> <p>1 The specified maximum address is fixed</p> <p>0 The specified maximum address is not fixed and can be changed</p> <p>Bit [2] Min Address Fixed, <i>_MIF</i>:</p> <p>1 The specified minimum address is fixed</p> <p>0 The specified minimum address is not fixed and can be changed</p> <p>Bit [1] Decode Type, <i>_DEC</i>:</p> <p>1 This bridge subtractively decodes this address (top level bridges only)</p> <p>0 This bridge positively decodes this address</p> <p>Bit [0] <i>Ignored</i></p>
Byte 5	Type Specific Flags	Flags that are specific to each resource type. The meaning of the flags in this field depends on the value of the Resource Type field (see above).
Byte 6	Address space granularity, <i>_GRA</i> bits[7:0]	A set bit in this mask means that this bit is decoded. All bits less significant than the most significant set bit must be set. (In other words, the value of the full Address Space Granularity field (all 16 bits) must be a number $(2^n - 1)$).
Byte 7	Address space granularity, <i>_GRA</i> bits[15:8]	
Byte 8	Address range minimum, <i>_MIN</i> , bits [7:0]	For bridges that translate addresses, this is the address space on the secondary side of the bridge.
Byte 9	Address range minimum, <i>_MIN</i> , bits [15:8]	
Byte 10	Address range maximum, <i>_MAX</i> , bits [7:0]	For bridges that translate addresses, this is the address space on the secondary side of the bridge.
Byte 11	Address range maximum, <i>_MAX</i> , bits [15:8]	
Byte 12	Address Translation offset, <i>_TRA</i> , bits [7:0]	For bridges that translate addresses across the bridge, this is the offset that must be added to the address on the secondary side to obtain the address on the primary side. Non-bridge devices must list 0 for all Address Translation offset bits.
Byte 13	Address Translation offset, <i>_TRA</i> , bits [15:8]	
Byte 14	Address Length, <i>_LEN</i> , bits [7:0]	
Byte 15	Address Length, <i>_LEN</i> , bits [15:8]	
Byte 16	Resource Source Index	(Optional) Only present if Resource Source (below) is present. This field gives an index to the specific resource descriptor that this device consumes from in the current resource template for the device object pointed to in Resource Source.
String	Resource Source	(Optional) If present, the device that uses this descriptor consumes its resources from the resources produced by the named device object. If not present, the device consumes its resources out of a global pool. If not present, the device consumes this resource from its hierarchical parent.

See WordIO, WordBusNumber, and ASL_WordAddressSpace for a description of the ASL macros that create a Word

address descriptor.

6.4.3.5.4 Extended Address Space Descriptor

Type 1, Large Item Value 0xB

The Extended Address Space descriptor is used to report resource usage in the address space (like memory and I/O).

Table 6.48: Extended Address Space Descriptor Definition

Offset	Field Name	Definition
Byte 0	Extended Address Space Descriptor	Value = 0x8B (10001011B) - Type = 1, Large item name = 0x0B
Byte 1	Length, bits[7:0]	Value = 0x35 (53)
Byte 2	Length, bits[15:8]	Value = 0x00
Byte 3	Resource Type	Indicates which type of resource this descriptor describes. Defined values are: 0 Memory range 1 I/O range 2 Bus number range 3-191 Reserved 192-255 Hardware Vendor Defined
Byte 4	General Flags	Flags that are common to all resource types: Bits [7:4] Reserved (must be 0) Bit [3] Max Address Fixed, _MAF: 1 The specified maximum address is fixed 0 The specified maximum address is not fixed and can be changed Bit [2] Min Address Fixed, _MIF: 1 The specified minimum address is fixed 0 The specified minimum address is not fixed and can be changed Bit [1] Decode Type, _DEC: 1 This bridge subtractively decodes this address (top level bridges only) 0 This bridge positively decodes this address Bit [0] Consumer/Producer: 1-This device consumes this resource 0-This device produces and consumes this resource
Byte 5	Type Specific Flags	Flags that are specific to each resource type. The meaning of the flags in this field depends on the value of the Resource Type field (see above). For the Memory Resource Type, the definition is defined in <i>Resource Type Specific Flags</i> . For other Resource Types, refer to the existing definitions for the Address Space Descriptors.
Byte 6	Revision ID	Indicates the revision of the Extended Address Space descriptor. For ACPI 3.0, this value is 1.
Byte 7	Reserved	0

continues on next page

Table 6.48 – continued from previous page

Byte 8	Address space granularity, _GRA bits[7:0]	A set bit in this mask means that this bit is decoded. All bits less significant than the most significant set bit must be set. That is, the value of the full Address Space Granularity field (all 64 bits) must be a number (2 ⁿ -1).
Byte 9	Address space granularity, _GRA bits[15:8]	
Byte 10	Address space granularity, _GRA bits[23:16]	
Byte 11	Address space granularity, _GRA bits[31:24]	
Byte 12	Address space granularity, _GRA bits[39:32]	
Byte 13	Address space granularity, _GRA bits[47:40]	
Byte 14	Address space granularity, _GRA bits[55:48]	
Byte 15	Address space granularity, _GRA bits[63:56]	
Byte 16	Address range minimum, _MIN bits[7:0]	For bridges that translate addresses, this is the address space on the secondary side of the bridge.
Byte 17	Address range minimum, _MIN bits[15:8]	
Byte 18	Address range minimum, _MIN bits[23:16]	
Byte 19	Address range minimum, _MIN bits[31:24]	
Byte 20	Address range minimum, _MIN bits[39:32]	
Byte 21	Address range minimum, _MIN bits[47:40]	
Byte 22	Address range minimum, _MIN bits[55:48]	
Byte 23	Address range minimum, _MIN bits[63:56]	
Byte 24	Address range maximum, _MAX bits[7:0]	For bridges that translate addresses, this is the address space on the secondary side of the bridge.
Byte 25	Address range maximum, _MAX bits[15:8]	
Byte 26	Address range maximum, _MAX bits[23:16]	
Byte 27	Address range maximum, _MAX bits[31:24]	
Byte 28	Address range maximum, _MAX bits[39:32]	For bridges that translate addresses, this is the address space on the secondary side of the bridge.
Byte 29	Address range maximum, _MAX bits[47:40]	
Byte 30	Address range maximum, _MAX bits[55:48]	
Byte 31	Address range maximum, _MAX bits[63:56]	

continues on next page

Table 6.48 – continued from previous page

Byte 32	Address Translation offset, _TRA bits[7:0]	For bridges that translate addresses across the bridge, this is the offset that must be added to the address on the secondary side to obtain the address on the primary side. Non-bridge devices must list 0 for all Address Translation offset bits.
Byte 33	Address Translation offset, _TRA bits[15:8]	
Byte 34	Address Translation offset, _TRA bits[23:16]	
Byte 35	Address Translation offset, _TRA bits[31:24]	
Byte 36	Address Translation offset, _TRA bits[39:32]	
Byte 37	Address Translation offset, _TRA bits[47:40]	
Byte 38	Address Translation offset, _TRA bits[55:48]	
Byte 39	Address Translation offset, _TRA bits[63:56]	
Byte 40	Address length, _LEN bits[7:0]	
Byte 41	Address length, _LEN, bits[15:8]	
Byte 42	Address length, _LEN bits[23:16]	
Byte 43	Address length, _LEN bits[31:24]	
Byte 44	Address length, _LEN bits[39:32]	
Byte 45	Address length, _LEN bits[47:40]	
Byte 46	Address length, _LEN bits[55:48]	
Byte 47	Address length, _LEN bits[63:56]	
Byte 48	Type Specific Attribute, _ATT bits[7:0]	Attributes that are specific to each resource type. The meaning of the attributes in this field depends on the value of the Resource Type field (see above). For the Memory Resource Type definition, see <i>Type Specific Attributes</i> . For other Resource Types, this field is reserved to 0.
Byte 49	Type Specific Attribute, _ATT bits[15:8]	
Byte 50	Type Specific Attribute, _ATT bits[23:16]	
Byte 51	Type Specific Attribute, _ATT bits[31:24]	
Byte 52	Type Specific Attribute, _ATT bits[39:32]	
Byte 53	Type Specific Attribute, _ATT bits[47:40]	
Byte 54	Type Specific Attribute, _ATT bits[55:48]	

continues on next page

Table 6.48 – continued from previous page

Byte 55	Type Specific Attribute, _ATT bits[63:56]	
---------	---	--

See *ExtendedSpace (Extended Address Space Resource Descriptor Macro)* for a description of the ASL macro that creates an Extended Address Space descriptor.

6.4.3.5.4.1 Type Specific Attributes

The meaning of the Type Specific Attributes field of the Extended Address Space Descriptor depends on the value of the Resource Type field in the descriptor. When Resource Type = 0 (memory resource), the Type Specific Attributes field values are defined per Memory Attribute Definitions in the *UEFI Specification* under the section titled *GetMemoryMap()*. This is the only well-defined and OS-agnostic mechanism for describing specific resource descriptor mapping attributes. For the architectural meaning behind the Memory Attribute Definitions, please see the ISA-specific binding in the Calling Conventions section of the UEFI Specification at <https://uefi.org/specifications>.

Note: EFI_MEMORY_WC is treated as equivalent to MEM == 3 for the purpose of describing PCI(e) RC resources matching prefetchable BAR requirements

6.4.3.5.5 Resource Type Specific Flags

The meaning of the flags in the Type Specific Flags field of the Address Space Descriptors depends on the value of the Resource Type field in the descriptor. The flags for each resource type are defined in the following tables:

Table 6.49: Memory Resource Flag (Resource Type = 0) Definitions

Bits	Meaning
Bits [7:6]	Reserved (must be 0)
Bit [5]	Memory to I/O Translation, _TTP: 1 TypeTranslation: This resource, which is memory on the secondary side of the bridge, is I/O on the primary side of the bridge. 0 TypeStatic: This resource, which is memory on the secondary side of the bridge, is also memory on the primary side of the bridge.
Bits [4:3]	Memory attributes, _MTP. These bits are only defined if this memory resource describes system RAM (see <i>System Address Map Interfaces</i>): 0 - AddressRangeMemory 1 - AddressRangeReserved 2 - AddressRangeACPI 3 - AddressRangeNVS

continues on next page

Table 6.49 – continued from previous page

Bits	Meaning
Bits [2:1]	<p>Memory attributes, <code>_MEM</code>:</p> <ul style="list-style-type: none"> 0 - The memory is non-cacheable: <ul style="list-style-type: none"> - To mean “uncached access” as defined below. 1 - The memory is cacheable 2 - The memory is cacheable and supports write combining: <ul style="list-style-type: none"> - Values 1 and 2 are deprecated. If they exist, they are interpreted as follows: <ul style="list-style-type: none"> - In the context of describing PCI/PCIe MMIO apertures, be treated equivalently to <code>_MEM == 3</code>. - In other contexts, to mean an “uncached access” (potentially equivalent to <code>_MEM == 0</code>) 3 - The memory is prefetchable: <ul style="list-style-type: none"> - In the context of describing PCI/PCIe MMIO apertures, this is used to define resources matching prefetchable BAR requirements. In this case, the value is interpreted to mean an “uncached access”, as defined below. - In other contexts, to mean an “uncached access” (potentially equivalent to <code>_MEM == 0</code>) <p>Note: For all above definitions, an “uncached access” is defined to be without any specific constraints, and made in an OS, driver, platform and architecture specific manner, where different uncached access types exist including reordering, prefetching, combining/grouping and early-acknowledgement.</p> <p>Note: OSPM ignores this field in the Extended address space descriptor. Instead, it uses the Type Specific Attributes field to determine memory attributes.</p>
Bit [0]	<p>Write status, <code>_RW</code>:</p> <ul style="list-style-type: none"> 1 - This memory range is read-write 0 - This memory range is read-only

Table 6.50: I/O Resource Flag (Resource Type = 1) Definitions

Bits	Meaning
Bits [7:6]	Reserved (must be 0)
Bit [5]	<p>Sparse Translation, <code>_TRS</code>. This bit is only meaningful if Bit [4] is set. 1 SparseTranslation: The primary-side memory address of any specific I/O port within the secondary-side range can be found using the following function. $address = (((port \& 0xFFFc) \ll 10) \parallel (port \& 0xFFF)) + _TRA$ In the address used to access the I/O port, bits[11:2] must be identical to bits[21:12], this gives four bytes of I/O ports on each 4 KB page. 0 DenseTranslation: The primary-side memory address of any specific I/O port within the secondary-side range can be found using the following function. $address = port + _TRA$</p>
Bit [4]	<p>I/O to Memory Translation, <code>_TTP</code> 1 TypeTranslation: This resource, which is I/O on the secondary side of the bridge, is memory on the primary side of the bridge. 0 TypeStatic: This resource, which is I/O on the secondary side of the bridge, is also I/O on the primary side of the bridge.</p>
Bit [3:2]	Reserved (must be 0)

continues on next page

Table 6.50 – continued from previous page

Bits	Meaning
Bit [1:0]	<p>0 ISARangesOnly. This flag is for bridges on systems with multiple bridges. Setting this bit means the memory window specified in this descriptor is limited to the ISA I/O addresses that fall within the specified window. The ISA I/O ranges are: n000-n0FF, n400-n4FF, n800-n8FF, nC00-nCFF. This bit can only be set for bridges entirely configured through ACPI namespace.</p> <p>1 NonISARangesOnly. This flag is for bridges on systems with multiple bridges. Setting this bit means the memory window specified in this descriptor is limited to the non-ISA I/O addresses that fall within the specified window. The non-ISA I/O ranges are: n100-n3FF, n500-n7FF, n900-nBFF, nD00-nFFF. This bit can only be set for bridges entirely configured through ACPI namespace.</p> <p>0 Reserved</p>

Table 6.51: **Bus Number Range Resource Flag (Resource Type = 2) Definitions**

Bits	Meaning
Bit [7:0]	Reserved (must be 0)

6.4.3.6 Extended Interrupt Descriptor

Type 1, Large Item Value 0x9

The Extended Interrupt Descriptor is necessary to describe interrupt settings and possibilities for systems that support interrupts above 15.

To specify multiple interrupt numbers, this descriptor allows vendors to list an array of possible interrupt numbers, any one of which can be used.

Table 6.52: **Extended Interrupt Descriptor Definition**

Offset	Field Name	Definition
Byte 0	Extended Interrupt Descriptor	Value = 0x89 (10001001B) - Type = 1, Large item name = 0x09
Byte 1	Length, bits [7:0]	Variable length, minimum value = 0x06
Byte 2	Length, bits [15:8]	Variable length, minimum value = 0x00

continues on next page

Table 6.52 – continued from previous page

Byte 3	Interrupt Vector Flags	<p>Interrupt Vector Information:</p> <p>Bit [7:5] Reserved (must be 0)</p> <p>Bit [4] Wake Capability, <i>_WKC</i>:</p> <p>0x0 = Not Wake Capable: This interrupt is not capable of waking the system.</p> <p>0x1 = Wake Capable: This interrupt is capable of waking the system from a low-power idle state or a system sleep state.</p> <p>Bit [3] Interrupt Sharing, <i>_SHR</i>:</p> <p>0x0 = Exclusive: This interrupt is not shared with other devices.</p> <p>0x1 = Shared: This interrupt is shared with other devices.</p> <p>Bit [2] Interrupt Polarity, <i>_LL</i>:</p> <p>0 Active-High: This interrupt is sampled when the signal is high, or true.</p> <p>1 Active-Low: This interrupt is sampled when the signal is low, or false.</p> <p>Bit [1] Interrupt Mode, <i>_HE</i>:</p> <p>0 Level-Triggered: Interrupt is triggered in response to the signal being in either a high or low state.</p> <p>1 Edge-Triggered: This interrupt is triggered in response to a change in signal state, either high to low or low to high.</p> <p>Bit [0] Consumer/Producer:</p> <p>1 This device consumes this resource</p> <p>0 This device produces this resource</p>
Byte 4	Interrupt table length	Indicates the number of interrupt numbers that follow. When this descriptor is returned from <i>_CRS</i> , or when OSPM passes this descriptor to <i>_SRS</i> , this field must be set to 1.
Byte 4 <i>n</i> +5	Interrupt Number, <i>_INT</i> bits [7:0]	Interrupt number
Byte 4 <i>n</i> +6	Interrupt Number, <i>_INT</i> bits [15:8]	
Byte 4 <i>n</i> +7	Interrupt Number, <i>_INT</i> bits [23:16]	
Byte 4 <i>n</i> +8	Interrupt Number, <i>_INT</i> bits [31:24]	
...	...	Additional interrupt numbers
Byte <i>x</i>	Resource Source Index	Reserved. If the platform specifies “Interrupt ResourceSource support” in bit 13 of <i>Platform-Wide _OSC Capabilities DWORD 2</i> , then this field must be zero.
String	Resource Source	(Optional) If present, the device that uses this descriptor consumes its resources from the resources produces by the named device object. If not present, the device consumes its resources out of a global pool.

Note: Low true, level sensitive interrupts may be electrically shared, the process of how this might work is beyond the scope of this specification.

If the OS is running using the 8259 interrupt model, only interrupt number values of 0-15 will be used, and interrupt numbers greater than 15 will be ignored. See the Interrupt section for a description of the ASL macro that creates an Extended Interrupt descriptor.

6.4.3.7 Generic Register Descriptor

Type 1, Large Item Value 0x2

The generic register descriptor describes the location of a fixed width register within any of the ACPI-defined address spaces. See *Generic Register Descriptor* for details.

Table 6.53: Generic Register Descriptor Definition

Offset	Field Name, ASL Field Name	Definition
Byte 0	Generic Register Descriptor	Value = 0x82 (10000010B) Type = 1, Large item name = 0x02
Byte 1	Length, bits[7:0]	Value = 0x0C (12)
Byte 2	Length, bits[15:8]	Value = 0x00
Byte 3	Address Space ID, _ASI	The address space where the data structure or register exists. Defined values are: 0x00 System Memory 0x01 System I/O 0x02 PCI Configuration Space 0x03 Embedded Controller 0x04 SMBus 0x05 SystemCMOS 0x06 PciBarTarget 0x07 IPMI 0x08 GeneralPurposeIO 0x09 GenericSerialBus 0x0A PCC 0x7F Functional Fixed Hardware
Byte 4	Register Bit Width, _RBW	Indicates the register width in bits.
Byte 5	Register Bit Offset, _RBO	Indicates the offset to the start of the register in bits from the Register Address.
Byte 6	Access Size, _ASZ	Specifies access size: 0 - Undefined (legacy reasons) 1 - Byte access 2 - Word access 3 - Dword access 4 - QWord access
Byte 7	Register Address, _ADR bits[7:0]	Register Address

continues on next page

Table 6.53 – continued from previous page

Byte 8	Register Address, _ADR bits[15:8]	
Byte 9	Register Address, _ADR bits[23:16]	
Byte 10	Register Address, _ADR bits[31:24]	
Byte 11	Register Address, _ADR bits[39:32]	
Byte 12	Register Address, _ADR bits[47:40]	
Byte 13	Register Address, _ADR bits[55:48]	
Byte 14	Register Address, _ADR bits[63:56]	

See Section 19.6.114 for a description of the Generic Register Resource Descriptor Macro.

6.4.3.8 Connection Descriptors

General-purpose I/O (GPIO) and Simple Peripheral Bus (SPB) controllers are hardware resources provided in silicon solutions to enable flexible configuration of a broad range of system designs. These controllers can provide input, output, interrupt and serial communication connections to arbitrary devices in a system. The function to which one of these connections is put depends on the specific device involved and the needs of the platform design. In order to support mobile platform architectures, ACPI abstracts these connections as resources.

6.4.3.8.1 GPIO Connection Descriptor

Type 1, Large Item Name 0xC

The GPIO Connection Descriptor describes connections between GPIO controllers and peripheral devices. Two types of GPIO connections can be described: IO connections and Interrupt connections, distinguished by the GPIO Connection Type value in the descriptor. GPIO controllers and the devices that connect to them may be located anywhere in the namespace, but the connection must be described in the peripheral device’s resource objects (PRS, _CRS, etc.).

Table 6.54: GPIO Connection Descriptor Definition

Offset	Field Name	Definition
Byte 0	GPIO Connection Descriptor	Value = 0x8C, (10001100B) - Type = 1, Large item name = 0x0C
Byte 1	Length, bits[7:0]	Variable length, minimum value = 0x16 + L (22 + length of the Resource Source Name string)
Byte 2	Length, bits[15:8]	Variable length, minimum value = 0x00
Byte 3	Revision ID	Indicates the revision for the GPIO interrupt descriptor. This value must be 1.
Byte 4	GPIO Connection Type	Indicates the type of the descriptor: 0x00 = Interrupt Connection 0x01 = IO Connection 0x02 - 0xFF Reserved
Byte 5	General Flags, bits [7:0]	Flags. Bit [7:1] Reserved (must be 0) Bit [0] Consumer/Producer: 0x0 = This device produces and consumes this resource 0x1 = This device consumes this resource
Byte 6	General Flags, bits [15:8]	Bit [15:8] Reserved (must be 0).

continues on next page

Table 6.54 – continued from previous page

Byte 7	Interrupt and IO Flags, bits [7:0] for Interrupt Connections	<p>Bit [7:5] Reserved (must be 0)</p> <p>Bit [4] Wake Capability, <code>_WKC</code>: 0x0 = Not Wake Capable: This interrupt is not capable of waking the system. 0x1 = Wake Capable: This interrupt is capable of waking the system from a low-power idle state or a system sleep state.</p> <p>Bit [3] Interrupt Sharing, <code>_SHR</code>: 0x0 = Exclusive: This interrupt is not shared with other devices. 0x1 = Shared: This interrupt is shared with other devices.</p> <p>Bit [2:1] Interrupt Polarity, <code>_POL</code>: 0x0 = Active-High: This interrupt is sampled when the signal is high, or true. 0x1 = Active-Low: This interrupt is sampled when the signal is low, or false. 0x2 = Active-Both: This interrupt is sampled on both rising and falling edges. Interrupt mode must be set to Edge-triggered. 0x3 - Reserved (do not use)</p> <p>Bit [0] Interrupt Mode, <code>_MOD</code> 0x0 = Level-Triggered: Interrupt is triggered in response to the signal being in either a high or low state. 0x1 = Edge-Triggered: This interrupt is triggered in response to a change in signal state, either high to low or low to high.</p>
Byte 7	Interrupt and IO Flags, bits [7:0] for IO Connections	<p>Bit [7:4] Reserved (must be 0)</p> <p>Bit [3] IO Sharing, <code>_SHR</code>: 0x0 = Exclusive: This IO connection is used exclusively by one device. 0x1 = Shared: This IO connection is shared by two or more devices.</p> <p>Bit [2] Reserved (must be 0)</p> <p>Bit [1:0] IO Restriction <code>_IOR</code>: 0x0 = This pin or pins can be used for either Input or Output. 0x1 = This pin or pins can only be used for Input, and the pin configuration must be preserved while not in use. 0x2 = This pin or pins can only be used for Output, and the pin configuration must be preserved while not in use. 0x3 = This pin or pins can be used for either input or output, but the configuration must be preserved until explicitly changed.</p>
Byte 8	Interrupt and IO Flags, bits [15:8]	Bit [15:8] Reserved (must be 0)

continues on next page

Table 6.54 – continued from previous page

Byte 9	Pin Configuration	<p><u>PPI:</u></p> <p>0x00 = Default Configuration (no configuration is applied) 0x01 = Pull-up 0x02 = Pull-down 0x03 = No Pull 0x04 - 0x7F; Reserved (do not use) 0x80 - 0xFF; Vendor-defined values</p>
Byte 10	Output Drive Strength, bits [7:0]	The output-drive capability, in hundredths of milliamperes, to be applied when configuring the pin for output (high byte). <u>DRS</u> [7:0]
Byte 11	Output Drive Strength, bits [15:8]	The output-drive capability, in hundredths of milliamperes, to be applied when configuring the pin for output (high byte). <u>DRS</u> [15:8]
Byte 12	Debounce timeout, bits [7:0]	The debounce timeout, in hundredths of milliseconds, to be applied when configuring the pin for interrupt (low byte). <u>DBT</u> [7:0]
Byte 13	Debounce timeout, bits [15:8]	The debounce timeout, in hundredths of milliseconds, to be applied when configuring the pin for interrupt (high byte). <u>DBT</u> [15:8]
Byte 14	Pin Table Offset[7:0]	Offset to the start of the pin table (low byte). The offset is relative to the start of this descriptor. NOTE: The number of pins in the table can be calculated from PinCount = (Resource Source Name Offset - Pin Table Offset) / 2
Byte 15	Pin Table Offset[15:8]	Offset to the start of the pin table (high byte). The offset is relative to the start of this descriptor.
Byte 16	Resource Source Index	Reserved for future use. This field must be 0.
Byte 17	Resource Source Name Offset[7:0]	Offset to the start of the resource source name (low byte). The offset is relative to the start of this descriptor. NOTE: The length of the ResourceSource name string can be calculated from Length L = Vendor Data Offset - Resource Source Name Offset. The length includes the string's terminating NULL character (if present)
Byte 18	Resource Source Name Offset[15:8]	Offset to the start of the resource source name (high byte). The offset is relative to the start of this descriptor.
Byte 19	Vendor Data Offset[7:0]	(low byte) Offset to the start of the Vendor-defined Data (the last byte of the ResourceSource + 1). This value must always be valid to allow for length calculations. In the case where there is no Vendor Data, this offset still must refer to the last byte of the Resource-Source + 1. The offset is relative to the start of this descriptor.
Byte 20	Vendor Data Offset[15:8]	(high byte) Offset to the start of the Vendor-defined Data (the last byte of the ResourceSource + 1). This value must always be valid to allow for length calculations. In the case where there is no Vendor Data, this offset still must refer to the last byte of the Resource-Source + 1. The offset is relative to the start of this descriptor.
Byte 21	Vendor Data Length [7:0]	Length of Vendor-defined Data (low-byte).
Byte 22	Vendor Data Length [15:8]	Length of Vendor-defined Data (high-byte).
Byte PinTable-Offset[15:0] + 2n (n is the index into the pin table)	Pin Number, bits [7:0]	<p>GPIO controller-relative pin number (low byte):</p> <p><u>PIN</u>[7:0]. Pin numbers are zero-based. Pin number 0xFFFF = No Pin. OSPM will ignore this pin number.</p>

continues on next page

Table 6.54 – continued from previous page

Byte PinTable- Offset[15:0] + 2n + 1 (n is the index into the pin table)	Pin Number, bits [15:8]	GPIO controller-relative pin number (high byte): _PIN[15:8]. Pin numbers are zero-based. Pin number 0xFFFF = No Pin. OSPM will ignore this pin number.
Byte ResourceSource- NameOffset[15:0]	Resource Source (length = L)	Name of the GPIO controller device to which this descriptor applies. The name can be a fully-qualified name, a relative name or a name segment that utilizes the namespace search rules.
Byte VendorDataOff- set[15:0]	Vendor-defined Data	(Optional) Data specific to the GPIO controller device supplied by a vendor. This data is provided to the device driver for this GPIO Controller. _VEN.

6.4.3.8.2 GenericSerialBus Connection Descriptors

Type 1, Large Item Value 0x0E

All Serial Bus Resource descriptors utilize the following format. For specific bus types, the type-specific fields are used.

Table 6.55: GenericSerialBus Connection Descriptors

Offset	Field Name	Definition
Byte 0	Serial Bus Type	Value = 0x8E (10001110B) - Type = 1, Large item name = 0x0E
Byte 1	Length, bits[7:0]	Variable length, minimum value = 0x09 + L(9 + ResourceSource string length)”
Byte 2	Length, bits[15:8]	Variable length, minimum value = 0x00
Byte 3	Revision ID	Indicates the revision of the Serial Bus Connection Descriptor. This value is 2.
Byte 4	Resource Source In- dex	Resource Connection Instance. If the device specified in the Resource Source field in this structure supports more than one connection (e.g. port), this field describes the instance of the connection to which this Device is connected.
Byte 5	Serial Bus Type	Indicates which type of serial bus connection this descriptor describes. Defined values are: 0 - Reserved 1 - I2C 2 - SPI 3 - UART 4 - CSI-2 5-191 - Reserved 192-255 - Hardware Vendor Defined

continues on next page

Table 6.55 – continued from previous page

Byte 6	General Flags [7:0]	<p>Flags that are common to all serial bus connection types:</p> <p>Bits[7:3] Reserved. Must be 0.</p> <p>Bit[2] Connection Sharing, _SHR: 0x0: Exclusive: This Serial Bus connection is used exclusively by one device. If Serial Bus Type is CSI, UART, or SPI then Bit 2 must be 0.</p> <p>Bit[1] Consumer/Producer: 0x1: This device consumes this resource 0x0: This device produces and consumes this resource</p> <p>Bit[0] Slave Mode: 0x1: The communication over this connection is initiated by the device. 0x0: The communication over this connection is initiated by the controller.</p>
Byte 7	Type Specific Flags, Bits[7:0]	Flags specific to the indicated Serial Bus Type (see above).
Byte 8	Type Specific Flags, bits[15:8]	Flags specific to the indicated Serial Bus Type (see above).
Byte 9	Type Specific Revision ID	Revision ID for the data describing the serial bus connection specified by Serial Bus Type (see above).
Byte 10	Type Data Length, bits[7:0]	Variable length, minimum size depends on the indicated Serial Bus Type (see above).
Byte 11	Type Data Length, bits [15:8]	Variable length, minimum size depends on the indicated Serial Bus Type (see above).
Byte 12	Type Specific Data	(Optional) Data specific to the serial bus connection type indicated in Serial Bus Type (see above).
...	...	Additional data specific to the serial bus connection type.
String	Resource Source	Name of the serial bus controller device to which this connection descriptor applies. The name can be a fully qualified path, a relative path, or a simple name segment that utilizes the namespace search rules.

6.4.3.8.2.1 I2C Serial Bus Connection Resource Descriptor

Table 6.56: I2C Serial Bus Connection Descriptor

Offset	Field Name	Definition
Byte 0	I2C Bus Connection Descriptor	Value = 0x8E (10001110B) - Type = 1, Large item name = 0x0E
Byte 1	Length, bits [7:0]	Variable length, minimum value = 0xF + L (15 + ResourceSource string length)
Byte 2	Length, bits [15:8]	Variable, length minimum value = 0x00
Byte 3	Revision ID	Indicates the revision for the I2C Resource Descriptor. This value is 2.
Byte 4	Resource Source Index	Master Instance. If the controller device specified in the Resource Source field in this structure supports more than one Master, this field describes the instance of the Master to which the I2C Slave is connected. The first Master Instance is 0.
Byte 5	Serial Bus Type	Serial Bus Type value must be 1 for I2C

continues on next page

Table 6.56 – continued from previous page

Byte 6	General Flags [7:0]	<p>Flags that are common to all serial bus connection types:</p> <p>Bits [7:3] Reserved. Must be 0.</p> <p>Bit [2] Connection Sharing, <code>_SHR</code>:</p> <p>0x1: Shared: This Serial Bus connection is shared by two or more devices.</p> <p>0x0: Exclusive: This Serial Bus connection is used exclusively by one device.</p> <p>Bit [1] Consumer/Producer:</p> <p>0x1: This device consumes this resource.</p> <p>0x0: This device produces and consumes this resource.</p> <p>Bit [0] Slave Mode, <code>_SLV</code>:</p> <p>0x1: This device consumes this resource.</p> <p>0x0: The communication over this connection is initiated by the control</p>
Byte 7	Type Specific Flags, Bits[7:0]:	<p>Bits[7:1] Reserved. Must be 0.</p> <p>Bit[0] 10-bit addressing mode, <code>_MOD</code>:</p> <p>0x1: The connection uses 10-bit addressing</p> <p>0x0: The connection uses 7-bit addressing.</p> <p>Note: If this device is connected to an I3C Host Controller, <code>_MOD</code> must be 0.</p>
Byte 8	Type Specific Flags, bits[15:8]	Legacy Virtual Register, <code>_LVR</code> This field is used to provide LVR data as specified in the MIPI I3C Specification for an I2C device connected to an I3C Host Controller. For I2C devices on an I2C bus, this field is Reserved and unused.
Byte 9	Type Specific Revision ID	Indicates the revision of the I2C-specific Serial Bus Connection Descriptor Data. This value is 1.
Byte 10	Type Data Length, bits[7:0]	Variable length, minimum value = 0x6 (6).
Byte 11	Type Data Length, bits [15:8]	Variable length, minimum size = 0x0 (0)
Byte 12	Connection Speed, bits [7:0]	Connection speed bits [7:0] of the maximum speed in hertz supported by this connection. <code>_SPE</code> [7:0]
Byte 13	Connection Speed, bits [15:8]	Connection speed bits [15:8] of the maximum speed in hertz supported by this connection. <code>_SPE</code> [15:8]
Byte 14	Connection Speed, bits [23:16]	Connection speed bits [23:16] of the maximum speed in hertz supported by this connection. <code>_SPE</code> [23:16]
Byte 15	Connection Speed, bits [31:24]	Connection speed bits [31:24] of the maximum speed in hertz supported by this connection. <code>_SPE</code> [31:24]
Byte 16	Slave Address, bits [7:0]	<p>Lower eight bits of the I2C bus address for this connection, <code>_ADR</code>[7:0]:</p> <p>Bits[6:0] The lowest 7 bits of the address. In 7-bit addressing mode this represents the complete address.</p>

continues on next page

Table 6.56 – continued from previous page

Byte 17	Slave Address, bits[15:8]	Upper eight bits of the I2C bus address for this connection. The upper eight bits are to support 10-bit addressing and should be set to 0 if 7-bit addressing is being used. _ADR[15:8] : Bits [15:10] Reserved. Must be 0. Bits [9:8] In 7-bit addressing mode these are reserved and must be 0. In 10-bit addressing mode these are the highest two bits of the address.
Byte 18	Vendor-defined Data	(Optional) Data specific to the controller device supplied by a vendor. The number of bytes in this field is Type Data Length - 6.
...	...	(Optional) Additional vendor supplied data.
String	Resource Source (Length = L)	Name of the serial bus controller device to which this connection descriptor applies. The name can be a fully qualified path, a relative path, or a simple name segment that utilizes the namespace search rules

6.4.3.8.2.2 SPI Serial Bus Connection Resource Descriptor

Table 6.57: SPI Serial Bus Connection Descriptor

Offset	Field Name	Definition
Byte 0	SPI Bus Connection Descriptor	Value = 0x8E (10001110B) - Type = 1, Large item name = 0x0E
Byte 1	Length, bits[7:0]	Variable length, minimum value = 0x12 + L (18 + Resource Source string length)
Byte 2	Length, bits[15:8]	Variable length, minimum value = 0x00
Byte 3	Revision ID	Indicates the revision of the Serial Bus Connection Descriptor. This value is 1.
Byte 4	Resource Source Index	Reserved (must be 0)
Byte 5	Serial Bus Type	Serial Bus Type value must be 2 for SPI
Byte 6	General Flags[7:0]	Flags that are common to all serial bus connection types. Bits[7:2] Reserved. Must be 0. Bit[1] Consumer/Producer: 0x1: This device consumes this resource 0x0: This device produces and consumes this resource Bit[0] Slave Mode, _SLV : 0x0: The communication over this connection is initiated by the controller. 0x1: The communication over this connection is initiated by the device.

continues on next page

Table 6.57 – continued from previous page

Byte 7	Type Specific Flags, bits[7:0]	<p>Bits [7:2] Reserved (must be 0)</p> <p>Bit[1]: Device Polarity, <code>_DPL</code></p> <p>1 - The device selection line is active high</p> <p>0 - The device selection line is active low</p> <p>Bit[0]: Wire Mode, <code>_MOD</code></p> <p>1 - The connection is over 3 wires</p> <p>0 - The connection is over 4 wires</p>
Byte 8	Type Specific Flags, bits[15:8]	Reserved. Must be 0.
Byte 9	Type Specific Revision ID	Indicates the revision of the SPI-specific Serial Bus Connection Descriptor Data. This value must be 1.
Byte 10	Type Data Length, bits[7:0]	Variable length, minimum value = 0x9 (9).
Byte 11	Type Data Length, bits [15:8]	Variable length, minimum size = 0x0 (0)
Byte 12	Connection Speed, bits [7:0]	Connection speed bits [7:0] of the maximum speed in hertz supported by this connection. <code>_SPE[7:0]</code>
Byte 13	Connection Speed, bits [15:8]	Connection speed bits [15:8] of the maximum speed in hertz supported by this connection. <code>_SPE[15:8]</code>
Byte 14	Connection Speed, bits [23:16]	Connection speed bits [23:16] of the maximum speed in hertz supported by this connection. <code>_SPE[23:16]</code>
Byte 15	Connection Speed, bits [31:24]	Connection speed bits [31:24] of the maximum speed in hertz supported by this connection. <code>_SPE[31:24]</code>
Byte 16	Data Bit Length	The size in bits of the smallest transfer unit. <code>_LEN</code>
Byte 17	Phase	<p>The phase (CPHA) of the clock pulse on which to capture data (the other being used to transmit), <code>_PHA</code>:</p> <p>0 - First phase</p> <p>1 - Second phase</p>
Byte 18	Polarity	<p>The polarity of the clock (CPOL). This value indicates if the clock is low or high during the first phase (see Phase above). <code>_POL</code></p> <p>0-Start Low</p> <p>1 -Start High</p>
Byte 19	Device Selection, bits [7:0]	Lower eight bits of the device selection value. This value is specific to the device and may refer to a chip-select line, GPIO line or other line selection mechanism. <code>_ADR[7:0]</code>
Byte 20	Device Selection, bits [15:8]	Upper eight bits of the device selection value. This value is specific to the device and may refer to a chip-select line, GPIO line or other line selection mechanism. <code>_ADR[15:8]</code>
Byte 21	Vendor Defined Data	(Optional) Data specific to the controller device supplied by a vendor. The number of bytes in this field is Type Data Length - 9.
...	...	(Optional) Additional vendor supplied data.
String	Resource Source (Length = L)	Name of the serial bus controller device to which this connection descriptor applies. The name can be a fully qualified path, a relative path, or a simple name segment that utilizes the namespace search rules.

6.4.3.8.2.3 UART Serial Bus Connection Resource Descriptor

Table 6.58: UART Serial Bus Connection Descriptor

Offset	Field Name	Definition
Byte 0	Serial Bus Connection Descriptor	Value = 0x8E (10001110B) - Type = 1, Large item name = 0x0E
Byte 1	Length, bits[7:0]	Variable length, minimum value = 0x13 + L (17 + Resource Source string length)
Byte 2	Length, bits[15:8]	Variable length, minimum value = 0x00
Byte 3	Revision ID	Indicates the revision of the Serial Bus Connection Descriptor. This value is 1.
Byte 4	Resource Source Index	Reserved (must be 0)
Byte 5	Serial Bus Type	Serial Bus Type value must be 3 for UART
Byte 6	General Flags [7:0]	<p>Flags that are common to all serial bus connection types.</p> <p>Bits[17:2] Reserved. Must be 0.</p> <p>Bit[1] Consumer/Producer:</p> <p> 0x1: This device consumes this resource</p> <p> 0x0: This device produces and consumes this resource</p> <p>Bit[0] Slave Mode. _SLV 0x0: The communication over this connection is initiated by the controller:</p> <p> 0x1: The communication over this connection is initiated by the device.</p>
Byte 7	Type Specific Flags, bits[7:0]	<p>Bit [7] - Endian-ness. _END</p> <p> Little Endian = 0</p> <p> Big Endian = 1</p> <p>Bit [6:4] - Data bits. Number of bits per byte. _LEN</p> <p> 000B - 5 bits</p> <p> 001B - 6 bits</p> <p> 010B - 7 bits</p> <p> 011B - 8 bits</p> <p> 100B - 9 bits</p> <p>Bits [3:2] - Stop Bits. Number of stop bits per character. _STB</p> <p> 00B (0) - none</p> <p> 01B (1) - 1</p> <p> 10B (2) - 1.5</p> <p> 11B (3) - 2 Bits [1:0] - Flow control. Indicates type of flow control for the connection. _FLC</p> <p> 00B (0) - None</p> <p> 01B (1) - Hardware flow control</p> <p> 10B (2) - XON/XOFF</p>
Byte 8	Type Specific Flags, bits[15:8]	Reserved. Must be 0.
Byte 9	Type Specific Revision ID	Indicates the revision of the UART-specific Serial Bus Connection Descriptor Data. This value must be 1.

continues on next page

Table 6.58 – continued from previous page

Byte 10	Type Data Length, bits[7:0]	Variable length, minimum value = 0x0A (10).
Byte 11	Type Data Length, bits [15:8]	Variable length, minimum size = 0x0 (0)
Byte 12	Default Baud rate, bits[7:0]	Default baud rate of connection, in bits-per-second. _SPE[7:0] Bits [7:0]
Byte 13	Default Baud rate, bits[15:8]	Default baud rate of connection, in bits-per-second. _SPE[15:8] Bits [15:8]
Byte 14	Default Baud rate, bits[23:16]	Default baud rate of connection, in bits-per-second. _SPE[23:16] Bits [23:16]
Byte 15	Default Baud rate, bits[31:24]	Default baud rate of connection, in bits-per-second. _SPE[31:24] Bits [31:24].
Byte 16	Rx FIFO, bits[7:0]	Maximum receive buffer, in bytes, supported by this connection. _RXL[7:0] Bits [7:0]
Byte 17	Rx FIFO, bits[15:8]	Maximum receive buffer, in bytes, supported by this connection. _RXL[15:8] Bits [15:8]
Byte 18	Tx FIFO, bits[7:0]	Maximum receive buffer, in bytes, supported by this connection. _TXL[7:0] Bits [7:0]
Byte 19	Tx FIFO, bits[15:8]	Maximum receive buffer, in bytes, supported by this connection. _TXL[15:8] Bits [15:8]
Byte 20	Parity	Parity. _PAR None = 0x00 Even = 0x01 Odd = 0x02 Mark = 0x03 Space = 0x04
Byte 21	Serial Lines Enabled	Serial lines enabled (Enabled = 1, Disabled = 0), _LIN: Bit [7] - Request to Send (RTS) Bit [6] - Clear to Send (CTS) Bit [5] - Data Terminal Ready (DTR) Bit [4] - Data Set Ready (DSR) Bit [3] - Ring Indicator (RI) Bit [2] - Data Carrier Detect (DTD) Bit [1] - Reserved. Must be 0. Bit [0] - Reserved. Must be 0.
Byte 22	Vendor Defined Data	(Optional) Data specific to the controller device supplied by a vendor. The number of bytes in this field is Type Data Length - 10.
...	...	(Optional) Additional vendor supplied data.
String	Resource Source (Length = L)	Name of the serial bus controller device to which this connection descriptor applies. The name can be a fully qualified path, a relative path, or a simple name segment that utilizes the namespace search rules.

6.4.3.8.2.4 Camera Serial Interface (CSI-2) Connection Resource Descriptor

Table 6.59: CSI-2 Connection Resource Descriptor

Offset	Field Name	Definition
Byte 0	CSI-2 Connection Descriptor	Value = 0x8E (10001110B) – Type = 1, Large item name = 0x0E
Byte 1	Length, bits [7:0]	Variable length, minimum value = 0xF + L (15 + ResourceSource string length)
Byte 2	Length, bits [15:8]	Variable, length minimum value = 0x00
Byte 3	Revision ID	Indicates the revision for the CSI Resource Descriptor. This value is 1.
Byte 4	Resource Source Index	Remote Port Instance. If the controller device specified in the Resource Source field in this structure supports more than one Port, this field describes the instance of the Port to which the CSI sensor is connected. The first Port instance is 0.
Byte 5	Serial Bus Type	Serial Bus Type value must be 4 for CSI-2
Byte 6	General Flags [7:0]	Flags that are common to all serial bus connection types: Bits [7:2] Reserved. Must be 0. Bit [1] Consumer/Producer: 0x0: This device produces and consumes this resource 0x1: This device consumes this resource Bit [0] Slave Mode. _SLV 0x0: The communication over this connection is initiated by the controller. 0x1: The communication over this connection is initiated by the device.
Byte 7	Type Specific Flags, bits[7:0]	Bits [7:2] Local Port Instance _PRT. If this device supports more than one local CSI-2 Port, this value reflects the index of the local Port for this connection. The first Port instance is 0. Bits [1:0] PHY Type _PHY: 00b - C-PHY 01b - D-PHY Other values Reserved
Byte 8	Type Specific Flags, bits[15:8]	<i>Reserved.</i> Must be 0.
Byte 9	Type Specific Revision ID	Indicates the revision of the CSI-specific Serial Bus Connection Descriptor Data. This value is 1.
Byte 10	Type Data Length, bits[7:0]	Variable length, minimum size = 0.
Byte 11	Type Data Length, bits [15:8]	Variable length, minimum size = 0.
Byte 12	Vendor-defined Data	(Optional) Data specific to the controller device supplied by a vendor. The number of bytes in this field is Type Data Length. _VEN

continues on next page

Table 6.59 – continued from previous page

...	...	(Optional) Additional vendor supplied data.
Byte 12 + Type Data Length (String)	Resource Source (Length = L)	Name of the CSI-2 controller device to which this connection descriptor applies. The name can be a fully qualified path, a relative path, or a simple name segment that utilizes the namespace search rules.

6.4.3.9 Pin Function Descriptor

Table 6.60: Pin Function Description Definition

Byte Offset	Field Name	Description
Byte 0	Resource Identifier	Value = 0x8D, (10001101B) - Type = 1, Large item name = 0x0D
Byte 1	Length, bits[7:0]	Variable length, minimum value = 0x0F + L (15 + length of the Resource Source Name string)
Byte 2	Length, bits[15:8]	Variable length, minimum value = 0x00
Byte 3	Revision ID	Indicates the revision for the Pin Function Descriptor. This value is 1
Byte 4	Flags [7:0]	Bit [7:1] - Reserved. Must be 0. Bit [0] - IO Sharing, _SHR 0x0 = Exclusive: This function is used exclusively by one device. 0x1 = Shared: This function is shared by two or more devices.
Byte 5	Flags [15:8]	Reserved. Must be 0.
Byte 6	Pin pull configuration	Can be one of PullDefault, PullUp, PullDown, PullNone or a vendor-supplied value in the range 128-255.
Byte 7	Function number (low byte)	The function number in which the pin is configured. This number is provider-specific.
Byte 8	Function number (high byte)	The function number in which the pin is configured. This number is provider-specific.
Byte 9	Pin table offset (low byte)	Offset to the start of the pin table (low byte). The offset is relative to the start of this descriptor.
Byte 10	Pin table offset (high byte)	Offset to the start of the pin table (high byte). The offset is relative to the start of this descriptor.
Byte 11	Resource source index	Reserved for future use. This field must be 0.
Byte 12	Resource source name index (low byte)	Offset to the start of the resource source name (low byte). The offset is relative to the start of this descriptor.

continues on next page

Table 6.60 – continued from previous page

Byte 13	Resource source name index (high byte)	Offset to the start of the resource source name (high byte). The offset is relative to the start of this descriptor.
Byte 14	Vendor data offset (low byte)	(low byte) Offset to the start of the Vendor-defined Data (the last byte of the Resource-Source + 1). This value must always be valid to allow for length calculations. In the case where there is no Vendor Data, this offset still must refer to the last byte of the ResourceSource + 1. The offset is relative to the start of this descriptor.
Byte 15	Vendor data offset (high byte)	(high byte) Offset to the start of the Vendor-defined Data (the last byte of the Resource-Source + 1). This value must always be valid to allow for length calculations. In the case where there is no Vendor Data, this offset still must refer to the last byte of the ResourceSource + 1. The offset is relative to the start of this descriptor.
Byte 16	Vendor data length (low byte)	Length of Vendor-defined Data (low-byte).
Byte 17	Vendor data length (high byte)	Length of Vendor-defined Data (high-byte).
Byte PinTableOffset[15:0] + 2n (n is the index into the pin table)Byte PinTableOffset[15:0] + 2n + 1 (n is the index into the pin table)	Pin Number, bits [15:8]	Provider-relative pin number (high byte). _PIN[15:8]. Pin numbers are zero-based.
Byte PinTableOffset[15:0] + 2n + 1 (n is the index into the pin table) Byte ResourceSourceNameOffset[15:0]	Resource Source (length = L)	Name of the function config provider to which this descriptor applies. The name can be a fully-qualified name, a relative name or a name segment that utilizes the namespace search
Byte VendorDataOffset[15:0]	Vendor-defined Data	(Optional) Data specific to the GPIO controller device supplied by a vendor. This data is provided to the device driver for this GPIO Controller. _VEN.

6.4.3.10 Pin Configuration Descriptor

Table 6.61: Pin Configuration Descriptor Definition

Byte Offset	Field Name	Description
Byte 0	Resource Identifier	Value = 0x8F, (10001110B) - Type = 1, Large item name = 0x0F
Byte 1	Length, bits[7:0]	Variable length, minimum value = 0x13 + L (19 + length of the Resource Source Name string)
Byte 2	Length, bits[15:8]	Variable length, minimum value = 0x00
Byte 3	Revision ID	Indicates the revision for the Function Configuration Descriptor. This value is 1

continues on next page

Table 6.61 – continued from previous page

Byte 4	Flags [7:0]	<p>Bit [7:2] - Reserved. Must be 0.</p> <p>Bit [1] - Consumer/Producer 0x1: This device consumes this resource 0x0: This device produces and consumes this resource</p> <p>Bit [0] - IO Sharing, _SHR 0x0 = Exclusive: This function is used exclusively by one device. 0x1 = Shared: This function is shared by two or more devices.</p>
Byte 5	Flags [15:8]	Reserved. Must be 0.
Byte6	Pin Configuration Type, _TYP	The pin configuration type (see Pin Configuration Types and Values).
Byte 7	Pin Configuration Value, _VAL, bits [7:0]	The pin configuration value associated with the pin configuration type (see Pin Configuration Types and Values).
Byte 8	Pin Configuration Value, _VAL, bits [15:8]	The pin configuration value associated with the pin configuration type (see Pin Configuration Types and Values).
Byte 9	Pin Configuration Value, _VAL, bits [23:16]	The pin configuration value associated with the pin configuration type (see Pin Configuration Types and Values).
Byte 10	Pin Configuration Value, _VAL, bits [31:24]	The pin configuration value associated with the pin configuration type (see Pin Configuration Types and Values).
Byte 11	Pin Table Offset[7:0]	Offset to the start of the pin table (low byte). The offset is relative to the start of this descriptor.
Byte 12	Pin Table Offset[15:8]	Offset to the start of the pin table (high byte). The offset is relative to the start of this descriptor.
Byte 13	Resource Source Index	Reserved for future use. This field must be 0.
Byte 14	Resource Source Name Offset[7:0]	Offset to the start of the resource source name (low byte). The offset is relative to the start of this descriptor.
Byte 15	Resource Source Name Offset[15:8]	Offset to the start of the resource source name (high byte). The offset is relative to the start of this descriptor.
Byte 16	Vendor Data Offset[7:0]	(low byte) Offset to the start of the Vendor-defined Data (the last byte of the Resource-Source + 1). This value must always be valid to allow for length calculations. In the case where there is no Vendor Data, this offset still must refer to the last byte of the ResourceSource + 1. The offset is relative to the start of this descriptor.

continues on next page

Table 6.61 – continued from previous page

Byte 17	Vendor Data Offset[15:8]	(high byte) Offset to the start of the Vendor-defined Data (the last byte of the ResourceSource + 1). This value must always be valid to allow for length calculations. In the case where there is no Vendor Data, this offset still must refer to the last byte of the ResourceSource + 1. The offset is relative to the start of this descriptor.
Byte 18	Vendor Data Length [7:0]	Length of Vendor-defined Data (low-byte).
Byte 19	Vendor Data Length [15:8]	Length of Vendor-defined Data (high-byte).
Byte PinTableOffset[15:0] + 2n (n is the index into the pin table)	Pin Number, _PIN, bits [7:0]	Provider-relative pin number (low byte). Pin numbers are zero-based.
Byte PinTableOffset[15:0] + 2n + 1 (n is the index into the pin table)	Pin Number, _PIN, bits [15:8]	Provider-relative pin number (high byte). Pin numbers are zero-based.
Byte ResourceSourceNameOffset[15:0]	Resource Source (length = L)	Name of the pin controller to which this descriptor applies. The name can be a fully-qualified name, a relative name or a name segment that utilizes the namespace search
Byte VendorDataOffset[15:0]	Vendor-defined Data, _VEN	(Optional) Data specific to the pin controller device supplied by a vendor. This data is provided to the device driver for this pin controller.

6.4.3.11 Pin Group Descriptor

Table 6.62: Pin Group Descriptor Definition

Byte Offset	Field Name	Description
Byte 0	Resource Identifier	Value = 0x90, (10010000B) - Type = 1, Large item name = 0x10
Byte 1	Length [7:0]	Variable length, minimum value = 0x0B + L (11 + length of the Resource Label)
Byte 2	Length [15:8]	Value = 0x00
Byte 3	Revision ID	Indicates the revision for the Pin Group Descriptor. This value is 1.
Byte 4	Flags [7:0]	Bits [7:1] Reserved. Must be 0. Bit [0] - Consumer/Producer: 0x1: This device consumes this resource 0x0: This device produces and consumes this resource
Byte 5	Flags [15:8]	Reserved. Must be 0.
Byte 6	Pin table offset [7:0]	Offset to the start of the pin table (low byte). The offset is relative to the start of this descriptor.

continues on next page

Table 6.62 – continued from previous page

Byte 7	Pin table offset [15:8]	Offset to the start of the pin table (high byte). The offset is relative to the start of this descriptor.
Byte 8	Resource label offset [7:0]	Offset to the start of the resource label (low byte). The offset is relative to the start of this descriptor. The length of the resource label string can be calculated from length $L = \text{Vendor data offset} - \text{Resource label offset}$. The length includes the string's terminating '0' character.
Byte 9	Resource label offset [15:8]	Offset to the start of the resource label (high byte). The offset is relative to the start of this descriptor.
Byte 10	Vendor data offset [7:0]	(low byte) Offset to the start of the Vendor-defined Data (the last byte of the Resource label offset (high byte) + 1). This value must always be valid to allow for length calculations. In the case where there is no Vendor Data, this offset still must refer to the last byte of the Resource label offset (high byte) + 1. The offset is relative to the start of this descriptor.
Byte 11	Vendor data offset [15:8]	(high byte) Offset to the start of the Vendor-defined Data (the last byte of the Pin table offset (high byte) + 1). This value must always be valid to allow for length calculations. In the case where there is no Vendor Data, this offset still must refer to the last byte of the Pin table offset (high byte) + 1. The offset is relative to the start of this descriptor.
Byte 12	Vendor data length [7:0]	Length of Vendor-defined Data (low-byte).
Byte 13	Vendor data length [15:8]	Length of Vendor-defined Data (high-byte).
Byte PinTableOffset[15:0] + 2n (n is the index into the pin table)	Pin Number, _PIN [7:0]	Provider-relative pin number (low byte). Pin numbers are zero-based.
Byte PinTableOffset[15:0] + 2n + 1 (n is the index into the pin table)	Pin Number, _PIN [15:8]	Provider-relative pin number (high byte). Pin numbers are zero-based.
Byte ResourceLabelOffset[15:0]	Resource Label (length = L)	Label for the resource (string). Can be any non-empty string and is used by resource consumers to refer to this resource by name. Always terminated by '0'.
Byte VendorDataOffset[15:0]	Vendor-defined Data, _VEN	(Optional) Data specific to the GPIO controller device supplied by a vendor. This data is provided to the device driver for this GPIO Controller.

6.4.3.12 Pin Group Function Descriptor

Table 6.63: Pin Group Function Descriptor Definition

Byte Offset	Field Name	Description
Byte 0	Resource Identifier	Value = 0x91, (10010001B) - Type = 1, Large item name = 0x11
Byte 1	Length [7:0]	Variable length, minimum value = 0x0E + L1 + L2 (14 + length of the Resource Source Name string + length of the Resource Source Label string)
Byte 2	Length [15:8]	Variable length, minimum value = 0x00
Byte 3	Revision ID	Indicates the revision for the Pin Function Descriptor. This value is 1
Byte 4	Flags [7:0]	<p>Bits [7:2] - Reserved. Must be 0.</p> <p>Bit [1] - Consumer/Producer</p> <p>0x1: This device consumes this resource</p> <p>0x0: This device produces and consumes this resource</p> <p>Bit [0] - IO Sharing, _SHR</p> <p>0x0 = Exclusive: This function is used exclusively by one device</p> <p>0x1 = Shared: This function is shared by two or more devices.</p>
Byte 5	Flags [15:8]	Reserved. Must be 0.
Byte 6	Function number, _FUN [7:0]	The function number in which the pin is configured. This number is provider-specific.
Byte 7	Function number, _FUN [15:8]	The function number in which the pin is configured. This number is provider-specific.
Byte 8	Resource source index	Reserved for future use. This field must be 0.
Byte 9	Resource source name index [7:0]	Offset to the start of the resource source name (low byte). The offset is relative to the start of this descriptor.
Byte 10	Resource source name index [15:8]	Offset to the start of the resource source name (high byte). The offset is relative to the start of this descriptor.
Byte 11	Resource source label offset [7:0]	Offset to the start of the Resource source label (low byte). The offset is relative to the start of this descriptor. The length of the resource source label string can be calculated from length L2 = Vendor data offset - Resource source label offset. The length includes the string's terminating '0' character.

continues on next page

Table 6.63 – continued from previous page

Byte 12	Resource source label offset [15:8]	Offset to the start of the resource source label (high byte). The offset is relative to the start of this descriptor.
Byte 13	Vendor data offset [7:0]	(low byte) Offset to the start of the Vendor-defined Data (the last byte of the Resource-Source + 1). This value must always be valid to allow for length calculations. In the case where there is no Vendor Data, this offset still must refer to the last byte of the ResourceSource + 1. The offset is relative to the start of this descriptor.
Byte 14	Vendor data offset [15:8]	(high byte) Offset to the start of the Vendor-defined Data (the last byte of the Resource-Source + 1). This value must always be valid to allow for length calculations. In the case where there is no Vendor Data, this offset still must refer to the last byte of the ResourceSource + 1. The offset is relative to the start of this descriptor.
Byte 15	Vendor data length [7:0]	Length of Vendor-defined Data (low-byte).
Byte 16	Vendor data length [15:8]	Length of Vendor-defined Data (high-byte).
Byte ResourceSourceNameOffset[15:0]	Resource Source (length = L1)	Name of the function config provider to which this descriptor applies. The name can be a fully-qualified name, a relative name or a name segment that utilizes the namespace search
Byte ResourceSourceLabelOffset[15:0]	Resource Source Label (length = L2)	This name refers to the PinGroup resource in the current resource template buffer of the GPIO controller. The PinGroup resource is matched by comparing its ResourceLabel string to this field. Always terminated by '0'.
Byte VendorDataOffset[15:0]	Vendor-defined Data, _VEN	(Optional) Data specific to the GPIO controller device supplied by a vendor. This data is provided to the device driver for this GPIO Controller.

6.4.3.13 Pin Group Configuration Descriptor

Table 6.64: Pin Group Configuration Descriptor Description

Byte Offset	Field Name	Description
Byte 0	Resource Identifier	Value = 0x92, (10010010B) - Type = 1, Large item name = 0x12
Byte 1	Length, bits[7:0]	Variable length, minimum value = 0x11 + L1 + L2 (17 + length of the Resource Source Name string + length of the Resource Source Label string)
Byte 2	Length, bits[15:8]	Variable length, minimum value = 0x00
Byte 3	Revision ID	Indicates the revision for the Function Configuration Descriptor. This value is 1

continues on next page

Table 6.64 – continued from previous page

Byte 4	Flags [7:0]	<p>Bit [7:2] - Reserved. Must be 0.</p> <p>Bit [1] - Consumer/Producer 0x1: This device consumes this resource 0x0: This device produces and consumes this resource</p> <p>Bit [0] - IO Sharing, _SHR 0x0 = Exclusive: This function is used exclusively by one device. 0x1 = Shared: This function is shared by two or more devices.</p>
Byte 5	Flags [15:8]	Reserved. Must be 0.
Byte 6	Pin Configuration Type, _TYP	The pin configuration type (see <i>Pin Group Configuration Types and Values</i>).
Byte 7	Pin Configuration Value, _VAL, bits [7:0]	The pin configuration value associated with the pin configuration type (see <i>Pin-Group-Configuration-Types-and-Values</i>).
Byte 8	Pin Configuration Value, _VAL, bits [15:8]	The pin configuration value associated with the pin configuration type (see <i>Pin-Group-Configuration-Types-and-Values</i>).
Byte 9	Pin Configuration Value, _VAL, bits [23:16]	The pin configuration value associated with the pin configuration type (see <i>Pin-Group-Configuration-Types-and-Values</i>).
Byte 10	Pin Configuration Value, _VAL, bits [31:24]	The pin configuration value associated with the pin configuration type (see <i>Pin-Group-Configuration-Types-and-Values</i>).
Byte 11	Resource Source Index	Reserved for future use. This field must be 0.
Byte 12	Resource Source Name Offset[7:0]	Offset to the start of the resource source name (low byte). The offset is relative to the start of this descriptor.
Byte 13	Resource Source Name Offset[15:8]	Offset to the start of the resource source name (high byte). The offset is relative to the start of this descriptor.
Byte 14	Resource source label offset (low byte)	Offset to the start of the resource source label (low byte). The offset is relative to the start of this descriptor. The length of the resource source label string can be calculated from length L2 = Vendor data offset - Resource source label offset. The length includes the string's terminating '0' character.
Byte 15	Resource source label offset (high byte)	Offset to the start of the resource source label (high byte). The offset is relative to the start of this descriptor.
Byte 16	Vendor Data Offset[7:0]	(low byte) Offset to the start of the Vendor-defined Data (the last byte of the ResourceSource + 1). This value must always be valid to allow for length calculations. In the case where there is no Vendor Data, this offset still must refer to the last byte of the ResourceSource + 1. The offset is relative to the start of this descriptor.
Byte 17	Vendor Data Off- set[15:8]	(high byte) Offset to the start of the Vendor-defined Data (the last byte of the ResourceSource + 1). This value must always be valid to allow for length calculations. In the case where there is no Vendor Data, this offset still must refer to the last byte of the ResourceSource + 1. The offset is relative to the start of this descriptor.
Byte 18	Vendor Data Length [7:0]	Length of Vendor-defined Data (low-byte).
Byte 19	Vendor Data Length [15:8]	Length of Vendor-defined Data (high-byte).

continues on next page

Table 6.64 – continued from previous page

Byte Resource-SourceNameOffset[15:0]	Resource Source (length = L1)	Name of the pin controller to which this descriptor applies. The name can be a fully-qualified name, a relative name or a name segment that utilizes the namespace search
Byte Resource-SourceLabelOffset[15:0]	Resource Source Label (length = L2)	This name refers to the PinGroup resource in current resource template buffer of the GPIO controller. The PinGroup resource is matched by comparing its ResourceLabel string to this field. Always terminated by '0'.
Byte Vendor-DataOffset[15:0]	Vendor-defined Data, _VEN	(Optional) Data specific to the pin controller device supplied by a vendor. This data is provided to the device driver for this pin controller.

6.4.3.14 Clock Input Resource Descriptor

A Clock Input Resource Descriptor is used to describe the frequency and source device of a clock input supplied by the platform to this Device. For a clock signal with a fixed frequency, a Clock Source entry is not required. If a Clock Source is provided, control of the clock is managed by that Clock Source Device. The frequency of the input clock is determined by Numerator and Divisor values along with a Scale value used for units. For example, a PCI clock could be described by a numerator of 100, a divisor of 3, and a Scale of MHz.

Table 6.65: Clock Resource Descriptor Definition

Byte Offset	Field Name	Description
Byte 0	Resource Identifier	Value = 0x93, (10010011B) - Type = 1, Large item name = 0x13
Byte 1	Length [7:0]	Variable length, minimum value = 0x0C + L (12 + length of the Resource Source)
Byte 2	Length [15:8]	Value = 0x00
Byte 3	Revision ID	Indicates the revision for the Clock Resource Descriptor. This value is 1.
Byte 4	Flags [7:0]	Bits [7:4] Reserved. Must be 0. Bits [3:1] Scale of value described in Clock Frequency 00b: Hz 01b: kHz 10b: MHz 11b: Reserved Bit [0] – Fixed/Variable: 0x1: The clock input frequency is variable and managed by the Clock Source specified by ResourceSource 0x0: The clock input frequency is fixed.
Byte 5	Flags [15:8]	Reserved. Must be 0.
Byte 6	Clock Frequency Divisor_FQD value, bits [7:0]	Clock frequency divisor value, bits [7:0]. This value is used to calculate the clock frequency. This value must not be zero.
Byte 7	Clock Frequency Divisor_FQD value, bits [15:8]	Clock frequency divisor value, bits [15:8]. This value is used to calculate the clock frequency. This value must not be zero.
Byte 8	Clock Frequency Numerator _FQN value, bits [7:0]	Clock frequency numerator, bits [7:0]. This value is used to calculate the clock frequency..Scale/unit is determined by Flags [3:1]

continues on next page

Table 6.65 – continued from previous page

Byte 9	Clock Frequency Numerator _FQN value, bits [15:8]	Clock frequency for this clock input, bits [15:8]. This value is used to calculate the clock frequency. Scale/unit is determined by Flags [3:1]
Byte 10	Clock Frequency Numerator _FQN value, bits [23:16]	Default frequency for this clock input, bits [23:16]. This value is used to calculate the clock frequency. Scale/unit is determined by Flags [3:1]
Byte 11	Clock Frequency Numerator _FQN value, bits [31:24]	Default frequency for this clock input, bits [31:24]. This value is used to calculate the clock frequency. Scale/unit is determined by Flags [3:1]
Byte 12	Clock Source Index	Clock Source Instance. If the Device specified in the Clock Source field in this structure supports more than one connection (e.g. clock output), this field describes the instance of the connection to which this Device is connected. If the Resource Source provides a single clock signal, or the clock source device is not specified, this field contains 0.
Byte 13	Clock Source (length = L)	Name of the Clock Source Device which supplies this clock signal. The name can be a fully qualified path, a relative path, or a simple name segment that utilizes the namespace search rules. This field is optional for a clock input with a fixed frequency (L = 0).

6.5 Other Objects and Control Methods

Table 6.66: Other Objects and Methods

Object	Description
_BBN	PCI bus number set up by the platform boot firmware.
_BDN	Correlates a docking station between ACPI and legacy interfaces.
_DCK	Indicates that the device is a docking station.
_DEP	Indicates device objects that OSPM should assign a higher priority in start ordering due to future operation region accesses.
_FIT	Object that evaluates to a buffer of NFIT Structures.
_GLK	Indicates the Global Lock must be acquired when accessing a device.
_INI	Device initialization method that is run shortly after ACPI has been enabled.
_LSI	Label Storage Information - Returns information about the Label Storage Area associated with the NVDIMM object, including its size.
_LSR	Label Storage Read - Returns label data from the Label Storage Area of the NVDIMM object.
_LSW	Label Storage Write - Writes label data in to the Label Storage Area of the NVDIMM object.
_REG	Notifies AML code of a change in the availability of an operation region.
_SEG	Indicates a bus segment location.

6.5.1 _INI (Init)

_INI is a device initialization object that performs device specific initialization. This control method is located under a device object and is run only when OSPM loads a description table. There are restrictions related to when this method is called and governing writing code for this method. The _INI method must only access Operation Regions that have been indicated to available as defined by the _REG method. The _REG method is described in *_REG (Region)*. This control method is run before _ADR, _CID, _HID, _SUN, and _UID are run.

Arguments:

None

Return Value:

None

Before evaluating the _INI object, OSPM evaluates the _STA object for the device. If the _STA object does not exist for the device, the device is assumed to be both present and functional. If the _STA method indicates that the device is present, OSPM will evaluate the _INI for the device (if the _INI method exists) and will examine each of the children of the device for _INI methods. If the _STA method indicates that the device is not present and is not functional, OSPM will not run the _INI and will not examine the children of the device for _INI methods. If the _STA object evaluation indicates that the device is not present but is functional, OSPM will not evaluate the _INI object, but will examine each of the children of the device for _INI objects (see the description of _STA for the explanation of this special case.) If the device becomes present after the table has already been loaded, OSPM will not evaluate the _INI method, nor examine the children for _INI methods.

The OSPM performed _INI object actions based upon the _STA Present and Functional bits are summarized in the table below.

Table 6.67: OSPM _INI Object Actions

_STA Present Bit	_STA Functional Bit	Actions
0	0	Do not run _INI, do not examine device children
0	1	Do not run _INI, examine device children
1	0	Run _INI, examine device children
1	1	Run _INI, examine device children

The _INI control method is generally used to switch devices out of a legacy operating mode. For example, platform boot firmware often configures CardBus controllers in a legacy mode to support legacy operating systems. Before enumerating the device with an ACPI operating system, the CardBus controllers must be initialized to CardBus mode. For such systems, the vendor can include an _INI control method under the CardBus controller to switch the device into CardBus mode.

In addition to device initialization, OSPM unconditionally evaluates an _INI object under the _SB namespace, if present, at the beginning of namespace initialization.

6.5.2 _DCK (Dock)

This control method is located in the device object that represents the docking station (that is, the device object with all the _EJx control methods for the docking station). The presence of _DCK indicates to the OS that the device is really a docking station.

_DCK also controls the isolation logic on the docking connector. This allows an OS to prepare for docking before the bus is activated and devices appear on the bus.

Arguments: (1)

Arg0 - An **Integer** containing a docking action code

- 0 - Undock (isolate from connector)
- 1 - Dock (remove isolation from connector)

Return Value:

An Integer containing the docking status code

- 1 - Successful
- 0 - Failed

Note: When `_DCK` is called with 0, OSPM will ignore the return value. The `_STA` object that follows the `_EJx` control method will notify whether or not the portable has been ejected.

6.5.3 `_BDN` (BIOS Dock Name)

`_BDN` is used to correlate a docking station reported via ACPI and the same docking station reported via legacy interfaces. It is primarily used for upgrading over non-ACPI environments.

Arguments:

None

Return Value:

An **Integer** that contains the EISA Dock ID

`_BDN` must appear under a device object that represents the dock, that is, the device object with `_Ejx` methods. This object must return a DWORD that is the EISA-packed DockID returned by the Plug and Play BIOS Function 5 (Get Docking Station Identifier) for a dock.

Note: If the machine does not support PNPBIOS, this object is not required.

6.5.4 `_REG` (Region)

The OS runs `_REG` control methods to inform AML code of a change in the availability of an operation region. When an operation region handler is unavailable, AML cannot access data fields in that region. (Operation region writes will be ignored and reads will return indeterminate data.)

Arguments: (2)

Arg0 – An Integer containing the Operation Region address space ID and optional supplementary qualifier (See Section 5.5.2.4 and Table 5.1.)

Arg1 - An Integer containing the handler connection code:

- | |
|--|
| <ul style="list-style-type: none">0 - disconnect the handler1 - connect the handler |
|--|

Return Value:

None

Except for the cases shown below, control methods must assume all operation regions are inaccessible until the `_REG(RegionSpace, 1)` method is executed, where `RegionSpace` is the address space ID, or the address space ID with an additional qualifier, depending on the operation region. For more information on which operation regions

have address space qualifiers, see *Access to Operation Regions*. Once `_REG` has been executed for a particular operation region, indicating that the operation region handler is ready, a control method can access fields in the operation region. Conversely, control methods must not access fields in operation regions when `_REG` method execution has not indicated that the operation region handler is ready.

For example, until the Embedded Controller driver is ready, the control methods cannot access the Embedded Controller. Once OSPM has run `_REG(EmbeddedControl, 1)`, the control methods can then access operation regions in Embedded Controller address space. Furthermore, if OSPM executes `_REG(EmbeddedControl, 0)`, control methods must stop accessing operation regions in the Embedded Controller address space.

The exceptions for the above rule are:

1. OSPM must guarantee that the following operation regions are always accessible: StepNumList-1
OSPM must guarantee that the following operation regions are always accessible:
 - PCI_Config operation regions on a PCI root bus containing a `_BBN` object.
 - SystemIO operation regions.
 - SystemMemory operation regions when accessing memory returned by the *System Address Map Interfaces*.

Note: Since the region types above are permanently available, no `_REG` methods are required, nor will OSPM evaluate any `_REG` methods that appear in the same scope as the operation region declaration(s) of these types.

2. OSPM must make Embedded Controller operation regions, accessed via the Embedded Controllers described in ECDT, available before executing any control method. These operation regions may become inaccessible after OSPM runs `_REG(EmbeddedControl, 0)`.

Place `_REG` in the same scope as operation region declarations. The OS will run the `_REG` in a given scope when the operation regions declared in that scope are available for use.

Example:

```
Scope (\_SB.PCI0) {
    OperationRegion(OPR1, PCI_Config, ...)
    Method(_REG, 2) {...}          // OSPM executes this when PCI0 operation region_
↪handler                          // status changes

    Device(PCI1) {
        Method(2) {...}
        Device(ETH0) {
            OperationRegion(OPR2, PCI_Config, ...)
            Method(_REG, 2) {...}
        }
    }

    Device(EC0) {
        Name(_HID, EISAID("PNP0C09"))
        OperationRegion(OPR4, EmbeddedControl, ...)
        Method(_REG, 2) {...}     // OSPM executes this when EC operation region
                                // handler status changes
    }
}
```

When the PCI0 operation region handler is ready, OSPM will run the `_REG` method declared in PCI0 scope to indicate that PCI Config space operation region access is available within the PCI0 scope (in other words, OPR1 access is allowed). Finally, when the Embedded Controller operation region handler is ready, OSPM will run the `_REG` method

in the EC0 scope to indicate that EC space operation region access is available within the EC0 scope (in other words, OPR4 access is allowed). It should be noted that PCI Config Space Operation Regions are ready as soon the host controller or bridge controller has been programmed with a bus number. PCI1's `_REG` method would not be run until the PCI-PCI bridge has been properly configured. At the same time, the OS will also run ETH0's `_REG` method since its PCI Config Space would be also available. The OS will again run ETH0's `_REG` method when the ETH0 device is started. Also, when the host controller or bridge controller is turned off or disabled, PCI Config Space Operation Regions for child devices are no longer available. As such, ETH0's `_REG` method will be run when it is turned off and will again be run when PCI1 is turned off.

Note: The OS only runs `_REG` methods that appear in the same scope as operation region declarations that use the operation region type that has just been made available. For example, `_REG` in the EC device would not be run when the PCI bus driver is loaded since the operation regions declared under EC do not use any of the operation region types made available by the PCI driver (namely, config space, I/O, and memory).

6.5.5 `_BBN` (Base Bus Number)

For multi-root PCI platforms, the `_BBN` object evaluates to the PCI bus number that the platform boot firmware assigns. This is needed to access a `PCI_Config` operation region for the specific bus. The `_BBN` object is located under a PCI host bridge and must be unique for every host bridge within a segment since it is the PCI bus number.

Arguments:

None

Return Value:

An Integer that contains the PCI bus number. The lower 8 bits of `_BBN` returned integer is the PCI Base Bus number. Other bits are reserved.

6.5.6 `_SEG` (Segment)

The optional `_SEG` object is located under a PCI host bridge and evaluates to an integer that describes the PCI Segment Group (see PCI Firmware Specification v3.0). If `_SEG` does not exist, OSPM assumes that all PCI bus segments are in PCI Segment Group 0.

Arguments:

None

Return Value:

PCI Segment Group is purely a software concept managed by system firmware and used by OSPM. It is a logical collection of PCI buses (or bus segments). There is no tie to any physical entities. It is a way to logically group the PCI bus segments and PCI Express Hierarchies. `_SEG` is a level higher than `_BBN`.

PCI Segment Group supports more than 256 buses in a system by allowing the reuse of the PCI bus numbers. Within each PCI Segment Group, the bus numbers for the PCI buses must be unique. PCI buses in different PCI Segment Group are permitted to have the same bus number.

A PCI Segment Group contains one or more PCI host bridges.

The lower 16 bits of `_SEG` returned integer is the PCI Segment Group number. Other bits are reserved.

Example:

```

Device(ND0) {                                     // this is a node 0
    Name(_HID, "ACPI0004")

    // Returns the "Current Resources"
    Name(_CRS,
        ResourceTemplate() {
            ...
        }
    )
    Device(PCI0) {
        Name(_HID, EISAID("PNP0A03"))
        Name(_ADR, 0x00000000)
        Name(_SEG, 0)           // The buses below the host bridge belong to PCI segment 0
        ...
        Name(_BBN, 0)
        ...
    }
    Device(PCI1) {
        ...
        Name(_SEG, 0)           // The buses below the host bridge belong to PCI segment 0
        ...
        Name(_BBN, 16)
        ...
    }
    ...
}
Device(ND1) {                                     // this is a node 1
    Name(_HID, "ACPI0004")

    // Returns the "Current Resources"
    Name(_CRS,
        ResourceTemplate() {
            ...
        }
    )
    Device(PCI0) {
        Name(_HID, EISAID("PNP0A03"))
        Name(_ADR, 0x00000000)
        Name(_SEG, 1)           // The buses below the host bridge belong to PCI segment 1
        ...
        Name(_BBN, 0)
        ...
    }
    Device(PCI1) {
        ...
        Name(_SEG, 1)           // The buses below the host bridge belong to PCI segment 1
        ...
        Name(_BBN, 16)
        ...
    }
}

```

6.5.7 _GLK (Global Lock)

This optional named object is located within the scope of a device object. This object returns a value that indicates to any entity that accesses this device (in other words, OSPM or any device driver) whether the Global Lock must be acquired when accessing the device. OS-based device accesses must be performed while in acquisition of the Global Lock when potentially contentious accesses to device resources are performed by non-OS code, such as System Management Mode (SMM)-based code in Intel architecture-based systems.

Note: Default behavior: if _GLK is not present within the scope of a given device, then the Global Lock is not required for that device.

Arguments:

None

Return Value:

An **Integer** that contains the Global Lock requirement code:

<pre>0 - The Global Lock is not required for this device 1 - The Global lock is required for this device</pre>
--

An example of device resource contention is a device driver for an SMBus-based device contending with SMM-based code for access to the Embedded Controller, SMB-HC, and SMBus target device. In this case, the device driver must acquire and release the Global Lock when accessing the device to avoid resource contention with SMM-based code that accesses any of the listed resources.

6.5.8 _DEP (Operation Region Dependencies)

_DEP evaluates to a package and designates device objects that OSPM should assign a higher priority in start ordering due to future operation region accesses.

To increase the likelihood that an SPB operation region handler is available when needed, OSPM needs to know in advance which methods will access it – _DEP provides OSPM with this information. While the _DEP keyword may be used to determine start ordering, only the _REG method (*_REG (Region)*) callbacks can be relied upon to determine whether a region is accessible at a given point in time.

Arguments:

None.

Return Value:

A variable-length **Package** containing object references.

Example:

```
Device (\_SB.TC3) {
    ...
    OperationRegion (OPRG,
        GenericSerialBus,
        0x00,
        0x100)
    ...
}
Device (\_SB.TP1) {
    ...
```

(continues on next page)

(continued from previous page)

```

Name (_DEP, Package() {\_SB.TC3})
...
}

```

6.5.9 _FIT (Firmware Interface Table)

This method evaluates to a buffer returning data in the format of a series of NFIT Structures (See *NVDIMM Firmware Interface Table (NFIT)*). This method may appear under the NVDIMM root device (see *NVDIMM Root Device*). The _FIT method, when present, is always evaluated by OSPM.

_FIT returns all the entries in the NFIT.

The NFIT Update Notification notification value for the NVDIMM root device (see *NVDIMM Root Device Notification Values*) notifies OSPM that it needs to re-evaluate the _FIT method.

Note: NFIT is an ACPI table enumerated at OS boot. In case of hot plug of NVDIMMs, the corresponding NFIT structures will not be present in NFIT. _FIT method is also used to provide these structures dynamically during hot plug.

Arguments:

None

Return Value:

A Buffer containing a list of NFIT Structures

Example ASL for _FIT usage:

```

Scope (\_SB) {
    Device (NVDR) {
        Name(_HID, "ACPI0012")
        OperationRegion (OPRN, SystemMemory,
            Offset in system memory of NFIT Structures, Length in bytes)
        Field (OPRN, ByteAcc, NoLock, Preserve) {
            FITD, Length in bits
        }
        Method (_FIT, 0) {
            Return (FITD)
        }
        ...
    } // end NVDR
    ...
} // end scope \_SB

```

6.5.10 NVDIMM Label Methods

The following table outlines the NVDIMM Label methods that are attached to the NVDIMM object.

Table 6.68: NVDIMM Label Methods

Object	Description
_LSI	Label Storage Information - Returns information about the Label Storage Area associated with the NVDIMM object, including its size.
_LSR	Label Storage Read - Returns label data from the Label Storage Area of the NVDIMM object.
_LSW	Label Storage Write - Writes label data in to the Label Storage Area of the NVDIMM object.

6.5.10.1 _LSI (Label Storage Information)

This optional object returns information about the Label Storage Area for the requested device.

Arguments:

None.

Return Value:

A **Package** containing the Label Storage Area information as described below

Return Value Information:

_LSI returns a package in the format below:

```
Package {
    Status // Integer (DWORD)
    SizeOfLabelStorageArea // Integer (DWORD)
    MaxTransferLength // Integer (DWORD)
}
```

Table 6.69: _LSI Return Package Values

Field	Format	Description
Status	Integer (DWORD)	Indicates the status of the _LSI request. 0x00000000 - Success - Returned package is valid 0x00000001 - Failure - The rest of the returned package is not valid
SizeOfLabelStorageArea	Integer (DWORD)	Size of the Label Storage Area in bytes
MaxTransferLength	Integer (DWORD)	Maximum amount of data in bytes supported by a single call to the _LSR and _LSW methods. This is the minimum of the platform supported transfer size and the transfer size supported by the NVDIMM. 0x00000000 - the NVDIMM does not support label storage. A non-zero value - the NVDIMM supports label storage.

6.5.10.2 _LSR (Label Storage Read)

This optional object returns label data from the Label Storage Area starting at the specified offset.

Arguments:

- Arg0 - Offset (Integer(DWORD)) the byte offset in the Label Storage Area to start reading from
- Arg1 - TransferLength (Integer(DWORD)) the number of bytes to transfer from the Label Storage Area. A TransferLength of 0 reads no data.

Return Value:

A Package containing label data from the Label Storage Area as described below

Return Value Information:

_LSR returns a package in the format below:

```
Package {
    Status          // Integer (DWORD)
    LabelData       // Buffer
}
```

Table 6.70: _LSR Return Package Values

Field	Format	Description
Status	Integer (DWORD)	<p>Indicates the status of the _LSR request:</p> <p>0x00000000 - Success</p> <p>0x00000001 - Failure</p> <p>0x00000002 - Invalid Input Parameters</p> <ul style="list-style-type: none"> - Offset > SizeOfLabelStorageArea reported with _LSI - Offset + TransferLength > SizeOfLabelStorageArea reported with _LSI - TransferLength > MaxTransferLength reported with _LSI <p>0x00000003 - Label Storage Area is locked and cannot be accessed</p> <p>0x00000004 - HW failure prevented data from being read</p> <p>Note: Any other non-zero values reflect a failure.</p>
LabelData	Buffer	<p>Contains the returned label storage data. The size of the output is equal to TransferLength if Status is Success; otherwise, the contents of the output buffer shall be 0. The format of the Label Storage Area data is defined in UEFI.</p>

6.5.10.3 _LSW (Label Storage Write)

This optional object writes label data to the Label Storage Area starting at the specified offset.

Arguments:

- Arg0 - Offset (Integer(DWORD)) the byte offset in the Label Storage Area to which the Label Data is to be written to the target NVDIMM
- Arg1 - TransferLength (Integer(DWORD)) the number of bytes to transfer to the Label Storage Area. A TransferLength of 0 writes no data.
- Arg2 - LabelData (Buffer) the label data to write in to the Label Storage Area. The size of the LabelData is as indicated by TransferLength field above. The format of the Label Storage Area data is defined in UEFI.

Return Value:

An Integer (DWORD) containing the status of the _LSW as follows:

- 0x00000000 - Success
- 0x00000001 - Failure
- 0x00000002 - Invalid Input Parameters:
 - Offset > SizeOfLabelStorageArea reported with _LSI
 - Offset + TransferLength > SizeOfLabelStorageArea reported with _LSI
 - TransferLength > MaxTransferLength reported with _LSI
- 0x00000003 - Label Storage Area is locked and cannot be accessed
- 0x00000004 - HW failure prevented data from being written

Note: Any other non-zero values indicate a failure.

6.5.11 _CBR (CXL Host Bridge Register Info)

This object is an optional control method that is invoked by OSPM to determine the memory location of CXL Host Bridge Registers and the version that represents the register layout. The _CBR object is located under a CXL Host Bridge Device and must return unique value for every CXL Host Bridge instance within a system.

For CXL host bridges that are present at boot time, CEDT shall provide the Host bridge register base address. The _UID object is required in the Host Bus Device in order to allow OSPM to match entries in the CEDT to devices present in the ACPI namespace.

For more information on CEDT, see <http://uefi.org/acpi> for the heading “CXL Early Discovery Table”.

Arguments:

None

Return Value:

A package containing the CXL Host Bridge Register Information as described below:

```
Package {
    Version,           //Integer (DWORD)
    Base,             //Integer (DWORDQWORD)
    Length            //Integer (DWORD)
}
```

Table 6.71: _CBR Return Package Values

Field	Format	Description
Version	Integer (DWORD)	The version number that represents the layout of Host Bridge Register Block: 0x00000000: Follow the CXL 1.1 Specification 0x00000001: Follow the CXL 2.0 Specification

continues on next page

Table 6.71 – continued from previous page

Base	Integer (QWORD)	64-bit memory address of the Host Bridge Register block: If Version = 0, this represents the base address of CXL 1.1 downstream port RCRB If Version = 1, this represents the base address of the CXL 2.0 Host Bridge Component Registers (CHBCR)
Length	Integer (DWORD)	Length of the Host Bridge Register Block in bytes: If Version = 0, this field must be set to 8 KB (0x2000) If Version = 1, this field must be set to 64 KB (0x10000)

Note: Links to the CXL 1.1 and CXL 2.0 Specifications can be found at <http://uefi.org/acpi>, under the corresponding headings for each spec.

Example:

```
Device(CXL0 ) {
    Name(_HID, "ACPI0016") // New HID to indicate CXL hierarchy
    Name(_CID, EISAID ("PNP0A08")) // To support legacy OSs that understands PCIe
                                // but not the new HID

    Name(_UID, 0)
    Method (_CBR, 0) {
        Return( 0x00, DP_RCRB_BASE, 0x2000)
    }
    // Standard PCIe methods like _BBN, _CRS.
    // PCIe _CRS describes .IO resources. PCIe _BBN describes bus number of CXL RCiEP
    // PCIe _OSC is used to negotiate control of CXL.IO capabilities
    ...
}
```

POWER AND PERFORMANCE MANAGEMENT

This section specifies the objects that support the device power management and system power management models described in *ACPI Concepts*. OSPM uses these objects to manage the platform by achieving a desirable balance between performance and energy conservation goals.

The system state indicator objects are also specified in this section.

7.1 Power Resource Objects and the Power Management Models

A Power Resource object refers to a software-controllable power plane, clock plane, or other resource upon which an ACPI power-managed device might rely. The unique way that these power resources are distributed to the devices across a given system sets the constraints within which OSPM must optimize the use of power, by individual devices as well as by the system as a whole. ACPI defines objects that reference power resources (or device states that, in turn, reference power resources) to enable OSPM to discover the constraints and capabilities of a given system. As power is managed during system operation, power savings are obtained by turning power resources off and on at the appropriate times. The following table describes how objects from this section provide the information and control required by OSPM to implement and coordinate the power management models.

Table 7.1: **Power Resource Object Provisions for Information and Control**

Power mgmt function to be performed	System entity performing it	Platform info required	Object providing information	Comments
Choose a supported device state to save power while device is idle	Device Power Policy Owner	List of states (D0 through D3hot, and D3cold) supported by the device	_PRx, PSx	D3cold support is indicated by explicitly providing _PR3. D3hot is assumed to be supported in all cases.

continues on next page

Table 7.1 – continued from previous page

Power mgmt function to be performed	System entity performing it	Platform info required	Object providing information	Comments
Choose a supported device state to enable a targeted system sleep or Low-power Idle state	Device Power Policy Owner	List of states (D0 through D3hot, and D3cold) supported by the device in the targeted system sleep state	_PRx, Power Resource Declaration, _SxD	_PRx maps device states to Power Resources, Power Resource definition maps Power Resources to system states. _SxD provides the system state-to-device state mapping explicitly in case power resources do not produce the information (*see note below).
Choose a device state that supports Wake	Device Power Policy Owner	List of supported states, filtered by ability to cause a wake event	_PRW, _SxW	Addition of the requirement for additional power resources listed in _PRW cause wake-incapable states to be removed from the list of supported states (above) SxW defines the mapping of wake capable device states to system states
Arm a device for wake	OSPM	Control mechanisms for enabling wake at the platform level	_PRW, Wake-capable device interrupt, _DSW	_PRW specifies the GPE bit to enable for wake. On HW-reduced platforms, the wake-capable attribute of a device interrupt indicates which interrupt to enable for wake _DSW is optional, depending on the needs of the platform wake hardware
Enter a selected device state	OSPM	Control mechanisms for power resources	_ON, _OFF, _PSx	_ON and _OFF control the power resources PSx controls other platform hardware relevant to state changes but not exposed to OSPM as power resources (*see note below).
Choose a targeted system sleep state	System Power Policy Owner	List of supported system Sleep states (S1-S4)	_Sx	S0 and S5 are assumed to be supported in all cases

continues on next page

Table 7.1 – continued from previous page

Power mgmt function to be performed	System entity performing it	Platform info required	Object providing information	Comments
Enter a selected system state	OSPM	Control mechanisms for system states	_PTS, _TTS and _WAK	If _S5 exists, ACPI uses the SLP_TYP/SLP_EN bit fields in the PM1 Control Register (or the SLEEP_CONTROL/ SLEEP_STATUS registers specified in the FADT). If _S5 is not specified, alternative methods are used to turn-off the system.

Note: * Support for Low-power Idle states requires the use of power resources to describe the device state and wake dependencies. See *Processor Aggregator Device* and *_LPI (Low Power Idle States)*.

7.2 Declaring a Power Resource Object

An ASL PowerResource statement is used to declare a PowerResource object. A Power Resource object refers to a software-controllable power plane, clock plane, or other resource upon which an integrated ACPI power-managed device might rely. Power resource objects can appear wherever is convenient in the namespace.

The syntax of a PowerResource statement is:

```
PowerResource (resourcename, systemlevel, resourceorder) {TermList}
```

where the systemlevel parameter is a number and the resourceorder parameter is a numeric constant (a WORD). For a formal definition of the PowerResource statement syntax, see [Section 7.2](#).

Systemlevel is the deepest system sleep level OSPM must maintain to keep this power resource on (0 equates to S0, 1 equates to S1, and so on).

Each power-managed ACPI device lists the resources it requires for its supported power states. OSPM multiplexes this information from all devices and then enables and disables the required Power Resources accordingly. The resource-order field in the Power Resource object is a value per Power Resource that provides the system with the order in which Power Resources must be enabled or disabled. Each unique resourceorder value represents a level, and any number of power resources may have the same level. Power Resource levels are enabled from low values to high values and are disabled from high values to low values. The operating software enables or disables all Power Resources in any one resourceorder level at a time before moving on to the next ordered level. Putting Power Resources in different order levels provides power sequencing and serialization where required. Note that no ordering is guaranteed within each level (i.e. between Power Resources with the same resourceorder value).

A Power Resource can have named objects under its Namespace location. For a description of the ACPI-defined named objects for a Power Resource, see *Device Power Management Objects*

The power management object list is encoded as TermList, so that rather than describing a static power management object list, it is possible to describe a dynamic power management object list according to the system settings. See *“Definition Block Loading”*.

The following ASL code block example demonstrates the use of a PowerResource:

```

PowerResource(PIDE, 0, 0) {
    Method(_STA) {
        Return (Xor (GIO.IDEI, One, Zero)) // inverse of isolation
    }
    Method(_ON) {
        Store (One, GIO.IDEP) // assert power
        Sleep (10) // wait 10ms
        Store (One, GIO.IDER) // de-assert reset#
        Stall (10) // wait 10us
        Store (Zero, GIO.IDEI) // de-assert isolation
    }
    Method(_OFF) {
        Store (One, GIO.IDEI) // assert isolation
        Store (Zero, GIO.IDER) // assert reset#
        Store (Zero, GIO.IDEP) // de-assert power
    }
}

```

7.2.1 Defined Methods for a Power Resource

The Power Resource Methods table below lists the control methods that may be defined under a power resource. `_ON`, `_OFF` and `_STA` are required to allow basic control of each power resource. `_RST` is required in cases where reset of devices is managed through a shared power resource. As OSPM changes the state of device objects in the system, the power resources that are needed will also change, causing OSPM to turn power resources on and off. To determine the initial power resource settings the `_STA` method can be used. `_RST` is required in cases where reset of devices is controlled through a shared Power Resource (see [_RST \(Device Reset\)](#)).

Table 7.2: Power Resource Methods

Object	Description
<code>_OFF</code>	Set the resource off.
<code>_ON</code>	Set the resource on.
<code>_RST</code>	Object that executes a platform level reset of all devices that list this resource in their <code>_PRR</code> object. (See _RST (Device Reset) for a description of this object.)
<code>_STA</code>	Object that evaluates to the current on or off state of the Power Resource. 0-OFF, 1-ON

7.2.2 `_OFF`

This power resource control method puts the power resource into the OFF state. The control method must not complete until the power resource is off, including any required sequencing delays between, or after, operations on the power resource. OSPM is required to turn on or off only one resource at a time. The AML code can use `Stall` or `Sleep` within the method to cause the proper sequencing delays. OSPM is not required to run the `_STA` method to confirm that the resource has been successfully turned off, and may run the `_OFF` method repeatedly, even if the resource is already off.

Arguments:

None

Return Value:

None

7.2.3 _ON

This power resource control method puts the power resource into the ON state. The control method must not complete until the power resource is on, including any required sequencing delays between, or after, operations on the power resource. OSPM is required to turn on or off only one resource at a time. The AML code can use Stall or Sleep within the method to cause the proper sequencing delays. OSPM is not required to run the _STA method to confirm that the resource has been successfully turned on, and may run the _ON method repeatedly, even if the resource is already on.

Arguments:

None

Return Value:

None

7.2.4 _STA (Power Resource Status)

Returns the current ON or OFF status for the power resource.

Arguments:

None

Return Value:

An Integer containing the current power status of the device:

- 0 - The power resource is currently off
- 1 - The power resource is currently on

7.2.5 Passive Power Resources

In some platforms, certain power resources may be shared between devices and processors, requiring both to be in specific idle states before they can be turned off. Direct OSPM control of such resources is not possible while the OS is running because the processors depend on the resources being enabled whilst they are running. It is only when processors go idle that it may be possible to turn off these shared resources. For a given resource of this type this is only possible if, in addition to the processors being idle, any other devices that depend on the resource are in a state that allows powering it down. In these cases, the platform can manage the power resource as part of entry/exit from a Low Power Idle (LPI) state and OSPM can guide the decision on whether or not to turn off the resources with its LPI state request. In those cases the power resource _ON/_OFF/_STA methods are completely redundant.

Passive power resources, which are just like traditional power resources except they do not include _ON, _OFF, or _STA, are introduced to support this case. Omission of these methods reduces overhead by avoiding redundant evaluations and saves the platform from having to supply (working) methods which it does not need. Since OSPM cannot manage passive power resources directly via _ON/_OFF, passive power resources must be listed as a dependency of at least one LPI state where the platform will manipulate them. The dependencies between LPI states and power resources are described in the _RDI object. See *[_RDI \(Resource Dependencies for Idle\)](#)* for additional details.

7.3 Device Power Management Objects

For a device that is power-managed using ACPI, a Definition Block contains one or more of the objects found in the table below. Power management of a device is done using Power Resource control.

Power Resources are resources that could be shared amongst multiple devices. The operating software will automatically handle control of these devices by determining which particular Power Resources need to be in the ON state at any given time. This determination is made by considering the state of all devices connected to a Power Resource. At all times, OSPM ensures that any Power Resources no longer referenced by any device in the system is in the OFF state.

For systems that do not control device power states through power resource management (i.e. `_PSx` controls power transitions), but whose devices support multiple D-states, more information is required by the OS to determine the S-state to D-state mapping for the device. The ACPI firmware can give this information to OSPM by way of the `_SxD` methods. These methods tell OSPM for S-state “x”, the shallowest D-state supported by the device is “y.” OSPM is allowed to pick a deeper D-state for a given S-state, but OSPM is not allowed to go shallower than the given D-state.

Additional rules that apply to device power management objects are:

- A device cannot be in a shallower D-state than its parent device.
- If there exists an ACPI Object to set a device to D0 (either through `_PSx` or `_PRx` objects), then the corresponding object to set the device into a deeper Dx must also be declared, and vice versa.
- If any ACPI Object that controls power (`_PSx` or `_PRx`, where x =0, 1, 2, or 3) exists, then methods to set the device into D0 and D3 device states (at least) must be present.
- If a mixture of `_PSx` and `_PRx` methods is declared for the device, then the device states supported through `_PSx` methods must be identical to the device states supported through `_PRx` methods.

Note: For non-ACPI devices (bus-enumerated devices like USB or PCI), architectural bus definitions may have more stringent requirements.

When controlling power to devices which must wake the system during a system sleeping state:

- The device must declare its ability to wake the system by declaring either the `_PRW` or `_PSW` object.
- After OSPM has called `_PTS`, it must call the device’s `_PSW` to enable wake.
- OSPM must transition a device into a D-state which is deeper than or equal to that specified by the device’s `_SxD` object (if present) to enable entry into Sx, but shallower than or equal to that specified by the device’s `_SxW` object so that it can still wake the system.
- OSPM may transition the system to the specified sleep state.

Table 7.3: Device Power Management Child Objects

Object	Description
<code>_DSW</code>	Control method that enables or disables the device’s wake function for device-only wake.
<code>_PS0</code>	Control method that puts the device in the D0 device state (device fully on).
<code>_PS1</code>	Control method that puts the device in the D1 device state.
<code>_PS2</code>	Control method that puts the device in the D2 device state.
<code>_PS3</code>	Control method that puts the device in the D3 device state (device off).
<code>_PSC</code>	Object that evaluates to the device’s current power state.
<code>_PR0</code>	Object that evaluates to the device’s power requirements in the D0 device state (device fully on).

continues on next page

Table 7.3 – continued from previous page

Object	Description
_PR1	Object that evaluates to the device's power requirements in the D1 device state. The only devices that supply this level are those that can achieve the defined D1 device state according to the related device class.
_PR2	Object that evaluates to the device's power requirements in the D2 device state. The only devices that supply this level are those that can achieve the defined D2 device state according to the related device class.
_PR3	Object that evaluates to the device's power requirements in the D3hot device state.
_PRW	Object that evaluates to the device's power requirements in order to wake the system from a system sleeping state.
_PSW	Control method that enables or disables the device's wake function.
_IRC	Object that signifies the device has a significant inrush current draw.
_S1D	Shallowest D-state supported by the device in the S1 state
_S2D	Shallowest D-state supported by the device in the S2 state
_S3D	Shallowest D-state supported by the device in the S3 state
_S4D	Shallowest D-state supported by the device in the S4 state
_S0W	Deepest D-state supported by the device in the S0 state which can wake the device
_S1W	Deepest D-state supported by the device in the S1 state which can wake the system.
_S2W	Deepest D-state supported by the device in the S2 state which can wake the system.
_S3W	Deepest D-state supported by the device in the S3 state which can wake the system.
_S4W	Deepest D-state supported by the device in the S4 state which can wake the system.
_RST	Control method that executes a function level reset of the device.
_PRR	Object that evaluates to the device's platform level reset requirements.
_DSC	Object that evaluates to the device's deepest power state for configuration.

7.3.1 _DSW (Device Sleep Wake)

In addition to _PRW, this control method can be used to enable or disable the device's ability to wake a sleeping system. This control method can only access Operation Regions that are either always available while in a system working state or that are available when the Power Resources referenced by the _PRW object are all ON. For example, do not put a power plane control for a bus controller within configuration space located behind the bus. The method should enable the device only for the last system state/device state combination passed in by OSPM. OSPM will only pass in combinations allowed by the _SxD and _SxW objects.

The arguments provided to _DSW indicate the eventual Device State the device will be transitioned to and the eventual system state that the system will be transitioned to. The target system state is allowed to be the system working state (S0). The _DSW method will be run before the device is placed in the designated state and also before the system is placed in the designated system state.

Compatibility Note: The _PSW method was deprecated in ACPI 3.0. The _DSW method should be used instead. OSPM will only use the _PSW method if OSPM does not support _DSW or if the _DSW method is not present.

Arguments (3):

- Arg0 - An **Integer** that contains the device wake capability control
 - 0 - Disable the device's wake capabilities
 - 1 - Enable the device's wake capabilities
- Arg1 - An **Integer** that contains the target system state (0-4)
- Arg2 - An **Integer** that contains the target device state
 - 0 - The device will remain in state D0

- 1 - The device will be placed in either state D0 or D1
- 2 - The device will be placed in either state D0, D1, or D2
- 3 - The device will be placed in either state D0, D1, D2, or D3

Return Value:

None

7.3.2 _PS0 (Power State 0)

This Control Method is used to put the specific device into its D0 state. This Control Method can only access Operation Regions that are either always available while in a system working state or that are available when the Power Resources references by the _PR0 object are all ON.

Arguments:

None

Return Value:

None

7.3.3 _PS1 (Power State 1)

This control method is used to put the specific device into its D1 state. This control method can only access Operation Regions that are either always available while in the system working state (S0) or that are available when the Power Resources referenced by the _PR0 object are all ON.

Arguments:

None

Return Value:

None

7.3.4 _PS2 (Power State 2)

This control method is used to put the specific device into its D2 state. This control method can only access Operation Regions that are either always available while in the system working state (S0) or that are available when the Power Resources referenced by the _PR0 and _PR1 objects are all ON.

Arguments:

None

Return Value:

None

7.3.5 **_PS3 (Power State 3)**

This control method is used to put the specific device into its D3 state. This control method can only access Operation Regions that are either always available while in the system working state (S0) or that are available when the Power Resources referenced by the _PR0, _PR1 and PR2 objects are all ON.

Arguments:

None

Return Value:

None

7.3.6 **_PSC (Power State Current)**

This control method evaluates to the current device state. This control method is not required if the device state can be inferred by the Power Resource settings. This would be the case when the device does not require a _PS0, _PS1, _PS2, or _PS3 control method.

Arguments:

None

Return Value:

An Integer that contains a code for the current device state. The device state codes are shown in the following table.

Table 7.4: **PSC Device State Codes**

0	D0
1	D1
2	D2
3	D3

7.3.7 **_PSE (Power State for Enumeration)**

This control method is used to put a device into a powered mode appropriate for enumeration by its parent bus. This control method can only access Operation Regions that are either always available while in a system working state or that are available when the Power Resources referenced by the _PRE object are all ON.

Arguments:

Arg1 - An Integer indicating whether Enumeration power has been turned ON or will be turned OFF:

- 0 - OFF
- 1 - ON

Return Value:

None

7.3.8 _PR0 (Power Resources for D0)

This object evaluates to a list of power resources upon which this device is dependent when it is operating in the D0 state. For OSPM to put the device into the D0 device state, the following must occur in this order:

1. All Power Resources referenced by elements 1 through N must be in the ON state.
2. All Power Resources no longer referenced by any device in the system must be in the OFF state.
3. If present, the _PS0 control method is executed to set the device into the D0 device state.

Arguments:

None

Return Value:

A variable-length Package containing a list of References to power resources.

This object returns a package as defined below:

Table 7.5: Power Resource Requirements Package

Element	Object	Description
1	object reference	Reference to required Power Resource #0
N	object reference	Reference to required Power Resource #N

_PR0 must return the same data each time it is evaluated. All power resources referenced must exist in the namespace.

7.3.9 _PR1 (Power Resources for D1)

This object evaluates to a list of power resources upon which this device is dependent when it is in the D1 state. For OSPM to transition the device from the D0 state into the D1 state, the following must occur, in order:

1. If present, the _PS1 control method is executed to set the device into the D1 device state.
2. All Power Resources referenced by elements 1 through N must be in the ON state.
3. All Power Resources no longer referenced by any device in the system must be in the OFF state.

Arguments:

None

Return Value:

A variable-length Package containing a list of References to power resources.

This object evaluates to a package as defined in *Power Resource Requirements Package*.

_PR1 must return the same data each time it is evaluated. All power resources referenced must exist in the namespace.

7.3.10 **_PR2 (Power Resources for D2)**

This object evaluates to a list of power resources upon which this device is dependent when it is in the D2 state. For OSPM to transition the device into the D2 state, the following must occur, in order:

1. If present, the `_PS2` control method is executed to set the device into the D2 device state.
2. All Power Resources referenced by elements 1 through N must be in the ON state.
3. All Power Resources no longer referenced by any device in the system must be in the OFF state.

Arguments:

None

Return Value:

A variable-length Package containing a list of References to power resources.

`_PR2` must return the same data each time it is evaluated. All power resources referenced must exist in the namespace.

7.3.11 **_PR3 (Power Resources for D3hot)**

This object evaluates to a list of power resources upon which this device is dependent when it is in the D3hot state. For OSPM to transition the device into the D3hot state, the following must occur, in order:

1. If present, the `_PS3` control method is executed to set the device into the D3hot device state.
2. All Power Resources referenced by elements 1 through N must be in the ON state.
3. All Power Resources no longer referenced by any device in the system must be in the OFF state.

Arguments:

None

Return Value:

A variable-length Package containing a list of References to power resources.

`_PR3` must return the same data each time it is evaluated. All power resources referenced must exist in the namespace.

Interaction between `_PR3` and entry to D3/D3hot (only applicable if platform and OSPM have performed the necessary handshake via `_OSC`):

- Platform/drivers must assume that the device will have power completely removed when the device is placed into “D3” via `_PS3`
- It is up to OSPM to determine whether to use D3 or D3hot. If there is a `_PR3` for the device, it is up to OSPM to decide whether to keep those power resources on or off after executing `_PS3`. The decision may be based on other factors (e.g., being armed for wake).

7.3.12 **_PRE (Power Resources for Enumeration)**

This object appears under a device and evaluates to a list of power resources that are required for enumeration of the device by its parent bus. For the bus driver to enumerate any devices while they are in the D3Cold device state, OSPM must ensure that the following occur:

1. All Power Resources referenced by elements 1 through N must be in the ON state.
2. If present, the **_PSE** control method is executed to perform any actions on the device to make it accessible for enumeration.

Arguments:

None

Return Value:

A variable-length Package containing a list of References to power resources.

_PRE must return the same data each time it is evaluated. All power resources referenced must exist in the namespace.

7.3.13 **_PRW (Power Resources for Wake)**

This object evaluates to a list of power resources upon which this device depends for wake. It also contains additional information needed for wake, including wake events and sleep or soft-off state information. **_PRW** is only required for devices that have the ability to wake the system from a system sleeping state.

Four types of general purpose events are supported:

- GPEs that are defined by a GPE block described within the FADT.
- GPEs that are defined by a GPE Block Device.
- GPIO-signaled events that are defined by **_AEI** object of the GPIO controller device
- Interrupt-signaled events that are defined by **_CRS** object of the Generic Event Device (GED)

The four types of events are differentiated by the type of the *EventInfo* object in the returned package. For FADT-based GPEs, *EventInfo* is an **Integer** containing a bit index. For Block Device-based GPEs, *EventInfo* is a **Package** containing a **Reference** to the parent block device and an **Integer** containing a bit index. For GPIO-signaled events, *EventInfo* is a **Package** containing a Reference to the GPIO controller device and an **Integer** containing the index of the event in the **_AEI** object (starting from zero). For Interrupt-signaled events, *EventInfo* is a **Package** containing a **Reference** to the GED and an **Integer** containing the index of the event in the **_CRS** object (starting from zero).

For HW-Reduced ACPI platforms that do not support wake on GPIO-signaled or Interrupt-signaled events, the *EventInfo* structure is an Integer with value of zero, and is ignored by OSPM. Therefore, **_PRW** is only required on such platforms if power resources for wakeup must be managed by OSPM (e.g. the **_PRW** provides a list of Power Resources). Instead, for a device to wake the system, its interrupt must be wake-capable and enabled by the driver. See *Interrupt-based Wake Events*.

Arguments:

None

Return Value:

A variable-length Package containing wake information and a list of References to power resources.

Return Value Information

```
Package {
    EventInfo                // Integer or Package
    DeepestSleepState       // Integer
    PowerResource [0]       // Reference
    . . .
    PowerResource [n]       // Reference
}
```

If *EventInfo* is a **Package**, it contains event block device information as described below:

```
Package {
    DeviceName               // Reference
    Index                    // Integer
}
```

EventInfo may be either an **Integer** or a **Package**, depending on the event type:

- If it is an **Integer**, then it contains the bit index of the wake event within the FADT-based GPE enable register.
- If it is a **Package**, then the package contains event info for an event within either a GPE block device, GPIO controller device, or a GED. It contains a **Reference** to the device and an **Integer**. If *EventInfo* references a GPE block device, the integer contains the bit index of the wake GPE within the Block Device-based GPE enable register. If the *EventInfo* references a GPIO controller device, the integer contains the zero-based index of the event within the *_AEI* object. If the *EventInfo* references a GED, the integer contains the zero-based index of the event within the *_CRS* object.

DeepestSleepState is an **Integer** that contains the deepest power system sleeping state that can be entered while still providing wake functionality.

PowerResource 0-n are **References** to required power resource objects.

Additional Information

For OSPM to have the defined wake capability properly enabled for the device, the following must occur:

1. All Power Resources referenced by elements 2 through N are put into the ON state.
 - a. If present, the *_DSW* control method is executed to set the device-specific registers to enable the wake functionality of the device.
 - b. The D-state being entered must be deeper than or equal to that specified in the *_SxD* state but shallower than or equal to that specified in the *_SxW* state.

Then, if the system enters a sleeping state OSPM must ensure:

2. Interrupts are disabled.
3. The sleeping state being entered must be less than or equal to the power state declared in element 1 of the *_PRW* object.
4. The proper general-purpose register bits are enabled.

The system sleeping state specified must be a state that the system supports (in other words, a corresponding *_Sx* object must exist in the namespace).

_PRW must return the same data each time it is evaluated. All power resources referenced must exist in the namespace.

7.3.14 **_PSW (Power State Wake)**

In addition to the `_PRW` control method, this control method can be used to enable or disable the device's ability to wake a sleeping system. This control method can only access Operation Regions that are either always available while in a system working state or that are available when the Power Resources references by the `_PRW` object are all ON. For example, do not put a power plane control for a bus controller within configuration space located behind the bus.

Note: Regarding compatibility—The `_PSW` method was deprecated in ACPI 3.0. OSPM must use `_DSW` if it is present. Otherwise, it may use `_PSW`.

Arguments: (1)

Arg0 - An Integer containing a wake capability control:

0 - Disable the device's wake capabilities

1 - Enable the device's wake capabilities

Return Value

None

7.3.15 **_IRC (In Rush Current)**

Indicates that this device can cause a significant in-rush current when transitioning to state D0.

Arguments:

None

Return Value:

None

The presence of this object signifies that transitioning the device to its D0 state causes a system-significant in-rush current load. In general, such operations need to be serialized such that multiple operations are not attempted concurrently. Within ACPI, this type of serialization can be accomplished with the `ResourceOrder` parameter of the device's Power Resources; however, this does not serialize ACPI-controlled devices with non-ACPI controlled devices. `_IRC` is used to signify this fact outside of OSPM to OSPM such that OSPM can serialize all devices in the system that have in-rush current serialization requirements.

OSPM can only transition one device containing an `_IRC` object within its device scope to the D0 state at a time.

It is important to note that OSPM does not evaluate the `_IRC` object. It has no defined input arguments nor does it return any value. OSPM derives meaning simply from the existence of the `_IRC` object.

7.3.16 **_S1D (S1 Device State)**

This object evaluates to an integer that conveys to OSPM the shallowest D-state supported by this device in the S1 system sleeping state. `_S1D` must return the same integer each time it is evaluated. This value overrides an S-state to D-state mapping OSPM may ascertain from the device's power resource declarations. See *PSC Device State Codes* for valid return values.

Arguments:

None

Return Value:

An **Integer** containing the shallowest D-state supported in state **S2**

If the device can wake the system from the S1 system sleeping state (see `_PRW`) then the device must support wake in the D-state returned by this object. However, OSPM cannot assume wake from the S1 system sleeping state is supported in any deeper D-state unless specified by a corresponding `_S1W` object. The table below provides a mapping from Desired Actions to Resultant D-state entered based on the values returned from the `_S1D`, `_PRW`, and `_S1W` objects if they exist. (D/C means Don't Care - evaluation is irrelevant, and N/A means Non Applicable - object does not exist).

Table 7.6: **S1 Action / Result Table**

Desired Action	<code>_S1D</code>	<code>_PRW</code>	<code>_S1W</code>	Resultant D-state
Enter S1	D/C	D/C	D/C	OSPM decides
Enter S1, No Wake	2	D/C	D/C	Enter D2 or D3
Enter S1, Wake	2	1	N/A	Enter D2
Enter S1, Wake	2	1	3	Enter D2 or D3
Enter S1, Wake	N/A	1	2	Enter D0,D1 or D2

7.3.17 `_S2D` (S2 Device State)

This object evaluates to an integer that conveys to OSPM the shallowest D-state supported by this device in the S2 system sleeping state. `_S2D` must return the same integer each time it is evaluated. This value overrides an S-state to D-state mapping OSPM may ascertain from the device's power resource declarations. See *PSC Device State Codes* for valid return values.

Arguments:

None

Return Value:

An **Integer** containing the shallowest D-state supported in state **S2**

If the device can wake the system from the S2 system sleeping state (see `_PRW`) then the device must support wake in the D-state returned by this object. However, OSPM cannot assume wake from the S2 system sleeping state is supported in any deeper D-state unless specified by a corresponding `_S2W` object. The table below provides a mapping from Desired Actions to Resultant D-state entered based on the values returned from the `_S2D`, `_PRW`, and `_S2W` objects if they exist. (D/C means Don't Care - evaluation is irrelevant, and N/A means Non Applicable - object does not exist).

Table 7.7: **S2 Action / Result Table**

Desired Action	<code>_S2D</code>	<code>_PRW</code>	<code>_S2W</code>	Resultant D-state
Enter S2	D/C	D/C	D/C	OSPM decides
Enter S2, No Wake	2	D/C	D/C	Enter D2 or D3
Enter S2, Wake	2	2	N/A	Enter D2
Enter S2, Wake	2	2	3	Enter D2 or D3
Enter S2, Wake	N/A	2	2	Enter D0,D1 or D2

7.3.18 **_S3D (S3 Device State)**

This object evaluates to an integer that conveys to OSPM the shallowest D-state supported by this device in the S3 system sleeping state. **_S3D** must return the same integer each time it is evaluated. This value overrides an S-state to D-state mapping OSPM may ascertain from the device’s power resource declarations. See *PSC Device State Codes* for valid return values.

Arguments:

None

Return Value:

An **Integer** containing the shallowest D-state supported in state **S3**

If the device can wake the system from the S3 system sleeping state (see **_PRW**) then the device must support wake in the D-state returned by this object. However, OSPM cannot assume wake from the S3 system sleeping state is supported in any deeper D-state unless specified by a corresponding **_S3W** object. The table below provides a mapping from Desired Actions to Resultant D-state entered based on the values returned from the **_S3D**, **_PRW**, and **_S3W** objects if they exist. (D/C means Don’t Care - evaluation is irrelevant, and N/A means Non Applicable - object does not exist).

Table 7.8: **S3 Action / Result Table**

Desired Action	_S3D	_PRW	_S3W	Resultant D-state
Enter S3	N/A	D/C	N/A	OSPM decides
Enter S3, No Wake	2	D/C	D/C	Enter D2 or D3
Enter S3, Wake	2	3	N/A	Enter D2
Enter S3, Wake	2	3	3	Enter D2 or D3
Enter S3, Wake	N/A	3	2	Enter D0, D1, or D2

7.3.19 **_S4D (S4 Device State)**

This object evaluates to an integer that conveys to OSPM the shallowest D-state supported by this device in the S4 system sleeping state. **_S4D** must return the same integer each time it is evaluated. This value overrides an S-state to D-state mapping OSPM may ascertain from the device’s power resource declarations. See *Table 7.9* for valid return values.

Arguments:

None

Return Value:

An **Integer** containing the shallowest D-state supported in state **S4**.

If the device can wake the system from the S4 system sleeping state (see **_PRW**) then the device must support wake in the D-state returned by this object. However, OSPM cannot assume wake from the S4 system sleeping state is supported in any deeper D-state unless specified by a corresponding **_S4W** object. The table below provides a mapping from Desired Actions to Resultant D-state entered based on the values returned from the **_S4D**, **_PRW**, and **_S4W** objects if they exist. (D/C means Don’t Care - evaluation is irrelevant, and N/A means Non Applicable - object does not exist).

Table 7.9: **S4 Action / Result Table**

Desired Action	_S4D	_PRW	_S4W	Resultant D-state
Enter S3	N/A	D/C	N/A	OSPM decides
Enter S4, No Wake	2	D/C	D/C	Enter D2 or D3

continues on next page

Table 7.9 – continued from previous page

Desired Action	_S4D	_PRW	_S4W	Resultant D-state
Enter S4, Wake	2	4	N/A	Enter D2
Enter S4, Wake	2	4	3	Enter D2 or D3
Enter S4, Wake	N/A	4	2	Enter D0, D1, or D2

7.3.20 _S0W (S0 Device Wake State)

This object evaluates to an integer that conveys to OSPM the deepest D-state supported by this device in the S0 system sleeping state where the device can wake itself.

Arguments:

None

Return Value:

An Integer containing the deepest D-state that supports wake in state S0. If OSPM has not indicated that it supports _PR3 through the OSPM Platform-Wide Capabilities (see *Platform-Wide OSPM Capabilities*), then the value “3” corresponds to D3. If it has indicated _PR3 support, the value “3” represents D3hot and the value “4” represents D3cold.

_S0W must return the same integer each time it is evaluated. This value allows OSPM to choose the deepest power D-state and still achieve wake functionality. If object evaluates to zero, then the device cannot wake itself from any deeper D state.

7.3.21 _S1W (S1 Device Wake State)

This object evaluates to an integer that conveys to OSPM the deepest D-state supported by this device in the S1 system sleeping state that can wake the system.

Arguments:

None

Return Value:

An Integer containing the deepest D-state that supports wake in state S1. If OSPM has not indicated that it supports _PR3 through the OSPM Platform-Wide Capabilities (see *Platform-Wide OSPM Capabilities*), then the value “3” corresponds to D3. If it has indicated _PR3 support, the value “3” represents D3hot and the value “4” represents D3cold.

_S1W must return the same integer each time it is evaluated. This value allows OSPM to choose a deeper S-state to D-state mapping than specified by _S1D. This value must always be greater than or equal to _S1D, if _S1D is present.

7.3.22 _S2W (S2 Device Wake State)

This object evaluates to an integer that conveys to OSPM the deepest D-state supported by this device in the S2 system sleeping state that can wake the system.

Arguments:

None

Return Value:

An Integer containing the deepest D-state that supports wake in state S2. If OSPM has not indicated that it supports `_PR3` through the OSPM Platform-Wide Capabilities (see *Platform-Wide OSPM Capabilities*), then the value “3” corresponds to D3. If it has indicated `_PR3` support, the value “3” represents D3hot and the value “4” represents D3cold.

`_S2W` must return the same integer each time it is evaluated. This value allows OSPM to choose a deeper S-state to D-state mapping than specified by `_S2D`. This value must always be greater than or equal to `_S2D`, if `_S2D` is present.

7.3.23 `_S3W` (S3 Device Wake State)

This object evaluates to an integer that conveys to OSPM the deepest D-state supported by this device in the S3 system sleeping state that can wake the system.

Arguments:

None

Return Value:

An Integer containing the deepest D-state that supports wake in state S3. If OSPM has not indicated that it supports `_PR3` through the OSPM Platform-Wide Capabilities (see *Platform-Wide OSPM Capabilities*), then the value “3” corresponds to D3. If it has indicated `_PR3` support, the value “3” represents D3hot and the value “4” represents D3cold.

`_S3W` must return the same integer each time it is evaluated. This value allows OSPM to choose a deeper S-state to D-state mapping than specified by `_S3D`. This value must always be greater than or equal to `_S3D`, if `_S3D` is present.

7.3.24 `_S4W` (S4 Device Wake State)

This object evaluates to an integer that conveys to OSPM the deepest D-state supported by this device in the S4 system sleeping state that can wake the system.

Arguments:

None

Return Value:

An Integer containing the deepest D-state that supports wake in state S4. If OSPM has not indicated that it supports `_PR3` through the OSPM Platform-Wide Capabilities (see *Platform-Wide OSPM Capabilities*), then the value “3” corresponds to D3. If it has indicated `_PR3` support, the value “3” represents D3hot and the value “4” represents D3cold.

`_S4W` must return the same integer each time it is evaluated. This value allows OSPM to choose a deeper S-state to D-state mapping than specified by `_S4D`. This value must always be greater than or equal to `_S4D`, if `_S4D` is present.

7.3.25 **_RST (Device Reset)**

This object executes a reset on the associated device or devices. If included in a device context, the reset must not affect any other ACPI-described devices; if included in a power resource for reset (**_PRR**), the reset must affect all ACPI-described devices that reference it.

When this object is described in a device context, it executes a function level reset that only affects the device it is associated with; neither parent nor children should be affected by the execution of this reset. Executing this must only result in this device resetting without the device appearing as if it has been removed from the bus altogether, to prevent OSPM re-enumeration of devices on hot-pluggable buses (e.g. USB).

If a device reset is supported by the platform, but cannot meet the function level and bus requirement, the device should instead implement a **_PRR** (***_PRR (Power Resource for Reset)***).

Devices can define both an **_RST** and a **_PRR** if supported by the hardware.

Arguments:

None

Return Value:

None

7.3.26 **_PRR (Power Resource for Reset)**

This object evaluates to a single reference to a power resource. The power resource that this references must implement a **_RST** method (***_RST (Device Reset)***).

Arguments:

None

Return Value:

A single element Package containing a Reference to the power reset resource.

7.3.27 **_DSC (Deepest State for Configuration)**

This optional object evaluates to an integer that conveys to OSPM the deepest D-state the device can be in before evaluating the **_CRS**, **_PRS** and **_SRS** configuration objects for it.

If **_DSC** is present and the current power state of the device is not deeper than the one represented by its return value, the device's **_CRS**, **_PRS** (if present) and **_SRS** (if present) configuration objects (see *Device Configuration Objects*) can be safely evaluated without putting the device into D0.

Therefore, when present, the **_DSC** object allows the OSPM to optimize device power management by avoiding an unnecessary change to device power state that would be otherwise made before evaluating configuration objects for the device.

Arguments:

None

Return Value:

An Integer representing the deepest D-state the device can be in during configuration. If OSPM has not indicated that it supports **_PR3** through the OSPM Platform-Wide Capabilities (see *Platform-Wide OSPM Capabilities*), then the value “3” corresponds to D3. If it has indicated **_PR3** support, the value “3” represents D3hot and the value “4” represents D3cold.

The `_DSC` return value must represent a D-state that is supported by the device. In particular, “4” (D3cold) can be returned only if `_PR3` is present.

`_DSC` must return the same integer each time it is evaluated.

The `_DSC` return value must not represent a D-state shallower than the one resulting from turning ON all of the power resources listed by `_PRE` (if present) and evaluating `_PSE` (if present).

7.4 OEM-Supplied System-Level Control Methods

An OEM-supplied Definition Block provides some number of controls appropriate for system-level management. These are used by OSPM to integrate to the OEM-provided features. The following table lists the defined OEM system controls that can be provided.

Table 7.10: BIOS-Supplied Control Methods for System-Level Functions

Object	Description
<code>_PTS</code>	Control method used to notify the platform of impending sleep transition.
<code>_S0</code>	Package that defines system <code>_S0</code> state mode.
<code>_S1</code>	Package that defines system <code>_S1</code> state mode.
<code>_S2</code>	Package that defines system <code>_S2</code> state mode.
<code>_S3</code>	Package that defines system <code>_S3</code> state mode.
<code>_S4</code>	Package that defines system <code>_S4</code> state mode.
<code>_S5</code>	Package that defines system <code>_S5</code> state mode.
<code>_TTS</code>	Control method used to prepare to sleep and run once awakened
<code>_WAK</code>	Control method run once awakened.

Note: Compatibility issue: The `_BFS` (Back From Sleep) and `_GTS` (Going To Sleep) methods were deprecated in ACPI 5.0A.

7.4.1 `_PTS` (Prepare To Sleep)

The `_PTS` control method is executed by the OS during the sleep transition process for S1, S2, S3, S4, and for orderly S5 shutdown. The sleeping state value (For example, 1, 2, 3, 4 or 5 for the S5 soft-off state) is passed to the `_PTS` control method. This method is called after OSPM has notified native device drivers of the sleep state transition and before the OSPM has had a chance to fully prepare the system for a sleep state transition. Thus, this control method can be executed a relatively long time before actually entering the desired sleeping state. If OSPM aborts the sleep state transition, OSPM should run the `_WAK` method to indicate this condition to the platform.

Arguments (1):

Arg0 - An Integer containing the value of the sleeping state (1 for S1, 2 for S2, etc.)

Return Value:

None

The `_PTS` control method cannot modify the current configuration or power state of any device in the system. For example, `_PTS` would simply store the sleep type in the embedded controller in sequencing the system into a sleep state when the `SLP_EN` bit is set.

The platform must not make any assumptions about the state of the machine when `_PTS` is called. For example, operation region accesses that require devices to be configured and enabled may not succeed, as these devices may be in a non-decoding state due to plug and play or power management operations.

7.4.2 _Sx (System States)

All system states supported by the system must provide a package containing the DWORD value of the following format in the static Definition Block. The system states, known as S0-S5, are referenced in the namespace as `_S0-_S5` and for clarity the short Sx names are used unless specifically referring to the named `_Sx` object. For each Sx state, there is a defined system behavior.

Arguments:

None

Return Value:

A Package containing an Integer containing register values for sleeping

Table 7.11: System State Package

Byte Length	Byte Offset	Description
1	0	Value for PM1a_CNT.SLP_TYP register to enter this system state. On HW-reduced platforms, this is the HW-reduced Sleep Type value for SLEEP_CONTROL_REG.SLP_TYP.
1	1	Value for PM1b_CNT.SLP_TYP register to enter this system state. To enter any given state, OSPM must write the PM1a_CNT.SLP_TYP register before the PM1b_CNT.SLP_TYP register. On HW-reduced platforms, this value is ignored.
2	2	<i>Reserved</i>

States S1-S4 represent some system sleeping state. The S0 state is the system working state. Transition into the S0 state from some other system state (such as sleeping) is automatic, and, by virtue that instructions are being executed, OSPM assumes the system to be in the S0 state. Transition into any system sleeping state is only accomplished by the operating software directing the hardware to enter the appropriate state, and the operating software can only do this within the requirements defined in the Power Resource and Bus/Device Package objects.

All run-time system state transitions (for example, to and from the S0 state), except S4 and S5, are done similarly such that the code sequence to do this is the following:

```

/*
 * Intel Architecture SetSleepingState example
 */

ULONG
SetSystemSleeping (
    IN    ULONG    NewState
)
{
    PROCESSOR_CONTEXT    Context;
    ULONG                PowerSequance;
    BOOLEAN              FlushCaches;
    USHORT               SlpTyp;

    // Required environment: Executing on the system boot
    // processor. All other processors stopped. Interrupts
    // disabled. All Power Resources (and devices) are in
    // corresponding device state to support NewState.

```

(continues on next page)

(continued from previous page)

```

// Get h/w attributes for this system state
FlushCaches = SleepType[NewState].FlushCache;
SlpTyp      = SleepType[NewState].SlpTyp & SLP_TYP_MASK;

_asm {
  lea   eax, OsResumeContext
  push  eax                                ; Build real mode handler the resume
  push  offset sp50                        ; context, with eip = sp50
  call  SaveProcessorState

  mov   eax, ResumeVector                  ; set firmware's resume vector
  mov   [eax], offset OsRealModeResumeCode

  mov   edx, PM1a_STS                      ; Make sure wake status is clear
  mov   ax, WAK_STS                        ; (cleared by asserting the bit
  out   dx, ax                             ; in the status register)

  mov   edx, PM1b_STS                      ;
  out   dx, ax                             ;

  and  eax, not SLP_TYP_MASK
  or   eax, SlpTyp                          ; set SLP_TYP
  or   ax, SLP_EN                            ; set SLP_EN

  cmp  FlushCaches, 0
  jz   short sp10                          ; If needed, ensure no dirty data in

  call  FlushProcessorCaches              ; the caches while sleeping

sp10:  mov   edx, PM1a_SLP_TYP              ; get address for PM1a_SLP_TYP
  out   dx, ax                             ; start h/w sequencing
  mov   edx, PM1b_SLP_TYP              ; get address for PM1b_SLP_TYP
  out   dx, ax                             ; start h/w sequencing

  mov   edx, PM1a_STS                    ; get address for PM1x_STS
  mov   ecx, PM1b_STS

sp20:  in   ax, dx                          ; wait for WAK status
  xchg  edx, ecx
  test  ax, WAK_STS
  jz   short sp20

sp50:
}

// Done..
*ResumeVector = NULL;
return 0;
}

```

On HW-reduced ACPI platforms all run-time system state transitions (for example, to and from the S0 state) are done similarly, but include the following instead of PM1*_BLK register bit manipulation:

After ensuring that any desired wake-capable interrupts are enabled, OSPM writes the HW-reduced Sleep Type value to the Sleep Control Register and spins waiting for the WAK_STS bit of the Sleep Status Register to be set, indicating a platform transition to the Working state.

7.4.2.1 System _S0 State (Working)

While the system is in the S0 state, it is in the system working state. The behavior of this state is defined as:

- The processors are either running, or in a C-state, or in an LPI state. The processor-complex context is maintained and instructions are executed as defined by any of these processor states.
- Dynamic RAM context is maintained and is read/write by the processors.
- Devices states are individually managed by the operating software and can be in any device state (D0, D1, D2, D3hot, or D3).
- Power Resources are in a state compatible with the current device states.

Transition into the S0 state from some system sleeping state is automatic, and by virtue that instructions are being executed OSPM, assumes the system to be in the S0 state.

7.4.2.2 System _S1 State (Sleeping with Processor Context Maintained)

While the system is in the S1 sleeping state, its behavior is the following:

- The processors are not executing instructions. The processor-complex context is maintained.
- Dynamic RAM context is maintained.
- Power Resources are in a state compatible with the system S1 state. All Power Resources that supply a System-Level reference of S0 are in the OFF state.
- Devices states are compatible with the current Power Resource states. Only devices that solely reference Power Resources that are in the ON state for a given device state can be in that device state. In all other cases, the device is in the D3 (off) state. (Or it is at least assumed to be in the D3 state by its device driver. For example, if the device doesn't explicitly describe how it can stay in some non-off state while the system is in a sleeping state, the operating software must assume that the device can lose its power and state.)
- Devices that are enabled to wake the system and that can do so from their current device state can initiate a hardware event that transitions the system state to S0. This transition causes the processor to continue execution where it left off.

To transition into the S1 state, the OSPM must flush all processor caches.

7.4.2.3 System _S2 State

The S2 sleeping state is logically deeper than the S1 state and is assumed to conserve more power. The behavior of this state is defined as:

- The processors are not executing instructions. The processor-complex context is not maintained.
- Dynamic RAM context is maintained.
- Power Resources are in a state compatible with the system S2 state. All Power Resources that supply a System-Level reference of S0 or S1 are in the OFF state.
- Devices states are compatible with the current Power Resource states. Only devices that solely reference Power Resources that are in the ON state for a given device state can be in that device state. In all other cases, the device is in the D3 (off) state.
- Devices that are enabled to wake the system and that can do so from their current device state can initiate a hardware event that transitions the system state to S0. This transition causes the processor to begin execution at its boot location. The platform runtime firmware performs initialization of core functions as needed to exit an S2 state and passes control to the firmware resume vector. See *Platform Boot Firmware Initialization of Memory* for more details on platform firmware initialization.

Because the processor context can be lost while in the S2 state, the transition to the S2 state requires that the operating software flush all dirty cache to dynamic RAM (DRAM).

7.4.2.4 System _S3 State

The S3 state is logically deeper than the S2 state and is assumed to conserve more power. The behavior of this state is defined as follows:

- The processors are not executing instructions. The processor-complex context is not maintained.
- Dynamic RAM context is maintained.
- Power Resources are in a state compatible with the system S3 state. All Power Resources that supply a System-Level reference of S0, S1, or S2 are in the OFF state.
- Devices states are compatible with the current Power Resource states. Only devices that solely reference Power Resources that are in the ON state for a given device state can be in that device state. In all other cases, the device is in the D3 (off) state.
- Devices that are enabled to wake the system and that can do so from their current device state can initiate a hardware event that transitions the system state to S0. This transition causes the processor to begin execution at its boot location. The platform runtime firmware performs initialization of core functions as necessary to exit an S3 state and passes control to the firmware resume vector. See *Platform Boot Firmware Initialization of Memory* for more details on platform firmware initialization.

From the software viewpoint, this state is functionally the same as the S2 state. The operational difference can be that some Power Resources that could be left ON to be in the S2 state might not be available to the S3 state. As such, additional devices may need to be in a deeper state for S3 than S2. Similarly, some device wake events can function in S2 but not S3.

Because the processor context can be lost while in the S3 state, the transition to the S3 state requires that the operating software flush all dirty cache to DRAM.

7.4.2.5 System _S4 State

While the system is in this state, it is in the system S4 sleeping state. The state is logically deeper than the S3 state and is assumed to conserve more power. The behavior of this state is defined as follows:

- The processors are not executing instructions. The processor-complex context is not maintained.
- DRAM context is not maintained.
- Power Resources are in a state compatible with the system S4 state. All Power Resources that supply a System-Level reference of S0, S1, S2, or S3 are in the OFF state.
- Devices states are compatible with the current Power Resource states. In other words, all devices are in the D3 state when the system state is S4.
- Devices that are enabled to wake the system and that can do so from their device state in S4 can initiate a hardware event that transitions the system state to S0. This transition causes the processor to begin execution at its boot location.

After OSPM has executed the `_PTS` control method and has put the entire system state into main memory, there are two ways that OSPM may handle the next phase of the S4 state transition; saving and restoring main memory. The first way is to use the operating system's drivers to access the disks and file system structures to save a copy of memory to disk and then initiate the hardware S4 sequence by setting the `SLP_EN` register bit. When the system wakes, the firmware performs a normal boot process and transfers control to the OS via the `firmware_waking_vector` loader. The OS then restores the system's memory and resumes execution.

The alternate method for entering the S4 state is to utilize the platform runtime firmware via the S4BIOS transition. The platform runtime firmware uses firmware to save a copy of memory to disk and then initiates the hardware S4 sequence. When the system wakes, the firmware restores memory from disk and wakes OSPM by transferring control to the FACS waking vector.

The S4BIOS transition is optional, but any system that supports this mechanism must support entering the S4 state via the direct OS mechanism. Thus the preferred mechanism for S4 support is the direct OS mechanism as it provides broader platform support. The alternate S4BIOS transition provides a way to achieve S4 support on operating systems that do not have support for the direct method.

7.4.2.6 System _S5 State (Soft Off)

The S5 state is similar to the S4 state except that OSPM does not save any context. The system is in the soft off state and requires a complete boot when awakened (platform boot firmware and OS). Software uses a different state value to distinguish between this state and the S4 state to allow for initial boot operations within the platform boot firmware to distinguish whether or not the boot is going to wake from a saved memory image. OSPM does not disable wake events before setting the SLP_EN bit when entering the S5 system state. This provides support for remote management initiatives by enabling Remote Start capability. An ACPI-compliant OS must provide an end user accessible mechanism for disabling all wake devices, with the exception of the system power button, from a single point in the user interface.

7.4.3 _SWS (System Wake Source)

This object provides a means for OSPM to definitively determine the source of an event that caused the system to enter the S0 state. General-purpose event and fixed-feature hardware registers containing wake event sources information are insufficient for this purpose as the source event information may not be available after transitions to the S0 state from all other system states (S1-S5).

To determine the source event that caused the system to transition to the S0 state, OSPM will evaluate the `_SWS` object, when it exists, under the `_GPE` scope (for all fixed-feature general-purpose events from the GPE Blocks), under the `_SB` scope (for fixed-feature hardware events), and within the scope of a GPE Block device (for GPE events from this device). `_SWS` objects may exist in any or all of these locations as necessary for the platform to determine the source event that caused the system to transition to the S0 state.

Arguments:

None

Return Value:

An Integer containing the Source Event as described below

The value of the Source Event is dependent on the location of the `_SWS` object:

1. If `_SWS` is evaluated under the `_GPE` scope, Source Event is the index of the GPE that caused the system to transition to S0. StepNumList-1 If `_SWS` is evaluated under the `_GPE` scope, Source Event is the index of the GPE that caused the system to transition to S0.
2. If `_SWS` is evaluated within the scope of a GPE block device, Source Event is the index of the GPE that caused the system to transition to S0. In this case, the index is relative to the GPE block device and is not unique system-wide.
3. If `_SWS` is evaluated under the `_SB` scope, Source Event is the the index in the PM1 status register that caused the system to transition to S0.

In all cases above, if the cause of the S0 transition cannot be determined, `_SWS` returns Ones (-1).

To enable OSPM to determine the source of the S0 state transition via the `_SWS` object, the hardware or firmware should detect and save the event that caused the transition so that it can be returned during `_SWS` object evaluation. The single wake source for the system may be latched in hardware during the transition so that no false wake events can be returned by `_SWS`. An implementation that does not use hardware to latch a single wake source for the system and instead uses firmware to save the wake source must do so as quickly as possible after the wakeup event occurs, so that `_SWS` does not return values that correspond to events that occurred after the sleep-to-wake transition. Such an implementation must also take care to ensure that events that occur subsequent to the wakeup source being saved do not overwrite the original wakeup source.

The source event data returned by `_SWS` must be determined for each transition into the S0 state. The value returned by `_SWS` must also be persistent during the system's residency in the S0 state as OSPM may evaluate `_SWS` multiple times. In this case, the platform must return the same source event information for each invocation.

After evaluating an `_SWS` object within the `_GPE` scope or within the scope of a GPE block device, OSPM will invoke the `_Wxx` control method corresponding to the GPE index returned by `_SWS` if it exists. This allows the platform to further determine source event if the GPE is shared among multiple devices. See *Determining the System Wake Source Using `_Wxx` Control Methods* for details.

7.4.4 `_TTS` (Transition To State)

The `_TTS` control method is executed by the OSPM at the beginning of the sleep transition process for S1, S2, S3, S4, and orderly S5 shutdown. OSPM will invoke `_TTS` before it has notified any native mode device drivers of the sleep state transition. The sleeping state value (For example, 1, 2, 3, 4 or 5 for the S5 soft-off state) is passed to the `_TTS` control method.

The `_TTS` control method is also executed by the OSPM at the end of any sleep transition process when the system transitions to S0 from S1, S2, S3, or S4. OSPM will invoke `_TTS` after it has notified any native mode device drivers of the end of the sleep state transition. The working state value (0) is passed to the `_TTS` control method.

Arguments:

Arg0 - An Integer containing the value of the sleeping state (1 for S1, 2 for S2, etc.)

Return Value

None

If OSPM aborts the sleep transition process, OSPM will still run `_TTS` for an S0 transition to indicate the OSPM has returned to the S0 state. The platform must assume that if OSPM invokes the `_TTS` control method for an S1, S2, S3, or S4 transition, that OSPM will invoke `_TTS` control method for an S0 transition before returning to the S0 state.

The platform must not make any assumptions about the state of the machine when `_TTS` is called. For example, operation region accesses that require devices to be configured and enabled may not succeed, as these devices may be in a non-decoding state due to plug and play or power management operations.

7.4.5 `_WAK` (System Wake)

After the system wakes from a sleeping state, it will invoke the `_WAK` method and pass the sleeping state value that has ended. This operation occurs asynchronously with other driver notifications in the system and is not the first action to be taken when the system wakes. The AML code for this control method issues device, thermal, and other notifications to ensure that OSPM checks the state of devices, thermal zones, and so on, that could not be maintained during the system sleeping state. For example, if the system cannot determine whether a device was inserted or removed from a bus while in the S2 state, the `_WAK` method would issue a `devicecheck` type of notification for that bus when issued with the sleeping state value of 2 (for more information about types of notifications, see *Device Object Notifications*).

Notice that a device check notification from the `_SB` node will cause OSPM to re-enumerate the entire tree. Only buses that support hardware-defined enumeration methods are done automatically at run-time. This would include ACPI-enumerated devices.

Hardware is not obligated to track the state needed to supply the resulting status; however, this method must return status concerning the last sleep operation initiated by OSPM. The return values can be used to provide additional information to OSPM or user.

Arguments:

Arg0 - An Integer containing the value of the sleeping state (1 for S1, 2 for S2, etc.)

Return value:

A Package containing two Integers containing status and the power supply S-state

Return Value Information

`_WAK` returns a package with the following format:

Element 0 - An Integer containing a bitfield that represents conditions that occurred during sleep:

- 0x00000000 - Wake was signaled and was successful
- 0x00000001 - Wake was signaled but failed due to lack of power
- 0x00000002 - Wake was signaled but failed due to thermal condition
- Other values - Reserved

Element 1 - An Integer containing the power supply S-state:

If non-zero, this is the effective S-state the power supply that was actually entered. This value is used to detect when the targeted S-state was not entered because of too much current being drawn from the power supply. For example, this might occur when some active device's current consumption pushes the system's power requirements over the low power supply mark, thus preventing the deeper system sleeping state from being entered as desired.

7.5 OSPM usage of `_PTS`, `_TTS`, and `_WAK`

OSPM will invoke `_PTS`, `_TTS`, and `_WAK` in the following order:

1. OSPM decides (through a policy scheme) to place the system into a sleeping state
2. `_TTS(Sx)` is run, where Sx is the desired sleep state to enter
3. OSPM notifies all native device drivers of the sleep state transition
4. `_PTS` is run
5. OSPM readies system for the sleep state transition
6. OSPM writes the sleep vector and the system enters the specified Sx sleep state
7. System Wakes up
8. OSPM readies system for the return from the sleep state transition
9. `_WAK` is run
10. OSPM notifies all native device drivers of the return from the sleep state transition
11. `_TTS(0)` is run to indicate the return to the S0 state

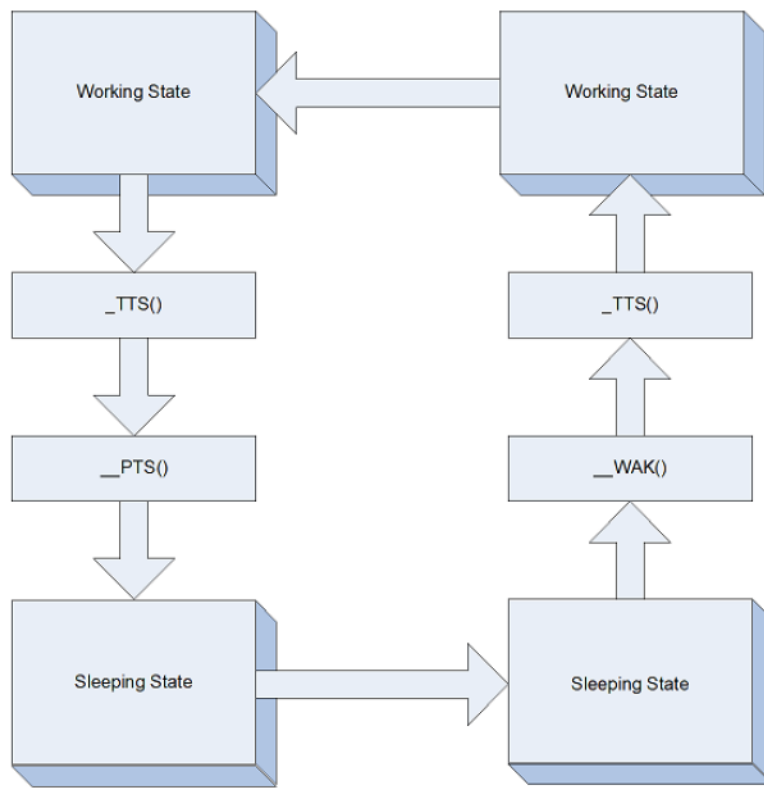

Fig. 7.1: Working / Sleeping State object evaluation flow

PROCESSOR CONFIGURATION AND CONTROL

This section describes the configuration and control of the processor's power and performance states. The major controls over the processors are:

- Processor power states: C0, C1, C2, C3, . . . Cn
- Processor clock throttling
- Processor performance states: P0, P1, . . . Pn

These controls are used in combination by OSPM to achieve the desired balance of the following sometimes conflicting goals:

- Performance
- Power consumption and battery life
- Thermal requirements
- Noise-level requirements

Because the goals interact with each other, the operating software needs to implement a policy as to when and where tradeoffs between the goals are to be made (see note below). For example the operating software would determine when the audible noise of the fan is undesirable and would trade off that requirement for lower thermal requirements, which can lead to lower processing performance. Each processor configuration and control interface is discussed in the following sections along with how controls interacts with the various goals.

Note: A thermal warning leaves room for operating system tradeoffs (to start the fan or reduce performance), without issuing a critical thermal alert.

8.1 Processor Power States

ACPI defines the power state of system processors while in the G0 working state as being either active executing or sleeping (not executing) - see note below. Processor power states include are designated C0, C1, C2, C3, . . . Cn. The C0 power state is an active power state where the CPU executes instructions. The C1 through Cn power states are processor sleeping states where the processor consumes less power and dissipates less heat than leaving the processor in the C0 state. While in a sleeping state, the processor does not execute any instructions. Each processor sleeping state has a latency associated with entering and exiting that corresponds to the power savings. In general, the longer the entry/exit latency, the greater the power savings when in the state. To conserve power, OSPM places the processor into one of its supported sleeping states when idle. While in the C0 state, ACPI allows the performance of the processor to be altered through a defined "throttling" process and through transitions into multiple performance states (P-states). A diagram of processor power states is provided below.

Note: These CPU states map into the G0 working state, and the Cx states only apply to the G0 state. In the G3 sleeping state, the state of the CPU is undefined.

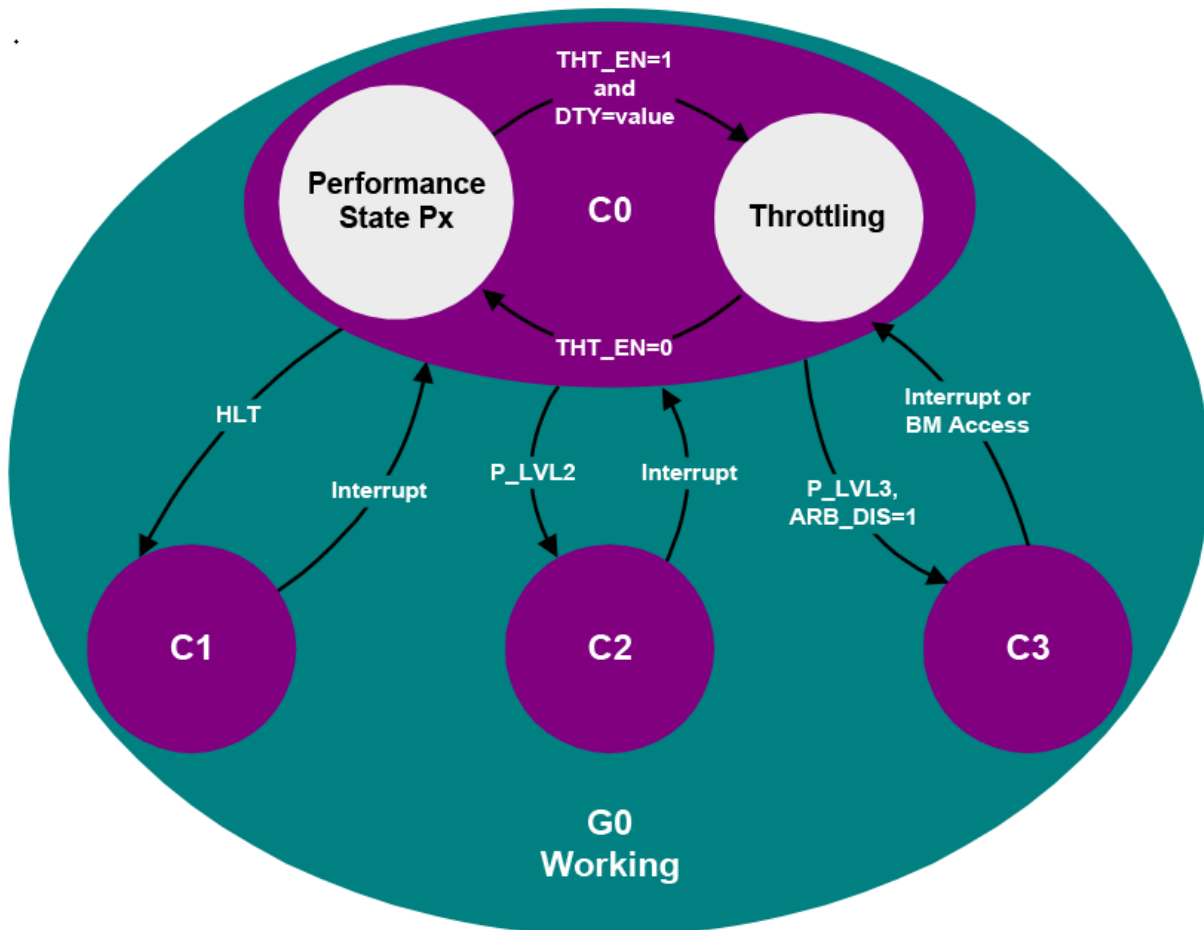

Fig. 8.1: Processor Power States

ACPI defines logic on a per-CPU basis that OSPM uses to transition between the different processor power states. This logic is optional, and is described through the FADT table and processor objects (contained in the hierarchical namespace). The fields and flags within the FADT table describe the symmetrical features of the hardware, and the processor object contains the location for the particular CPU's clock logic (described by the P_BLK register block and _CST objects).

The P_LVL2 and P_LVL3 registers provide optional support for placing the system processors into the C2 or C3 states. The P_LVL2 register is used to sequence the selected processor into the C2 state, and the P_LVL3 register is used to sequence the selected processor into the C3 state. Additional support for the C3 state is provided through the bus master status and arbiter disable bits (BM_STS in the PM1_STS register and ARB_DIS in the PM2_CNT register). System software reads the P_LVL2 or P_LVL3 registers to enter the C2 or C3 power state. The Hardware must put the processor into the proper clock state precisely on the read operation to the appropriate P_LVLx register. The platform may alternatively define interfaces allowing OSPM to enter C-states using the _CST object, which is defined in *_CST (C States)*.

Processor power state support is symmetric when presented via the FADT and P_BLK interfaces; OSPM assumes all processors in a system support the same power states. If processors have non-symmetric power state support, then the

platform runtime firmware will choose and use the lowest common power states supported by all the processors in the system through the FADT table. For example, if the CPU0 processor supports all power states up to and including the C3 state, but the CPU1 processor only supports the C1 power state, then OSPM will only place idle processors into the C1 power state (CPU0 will never be put into the C2 or C3 power states). Notice that the C1 power state must be supported. The C2 and C3 power states are optional (see the PROC_C1 flag in the FADT table description in *System Description Table Header*).

The following sections describe processor power states in detail.

8.1.1 Processor Power State C0

While the processor is in the C0 power state, it executes instructions. While in the C0 power state, OSPM can generate a policy to run the processor at less than maximum performance. The clock throttling mechanism provides OSPM with the functionality to perform this task in addition to thermal control. The mechanism allows OSPM to program a value into a register that reduces the processor’s performance to a percentage of maximum performance.

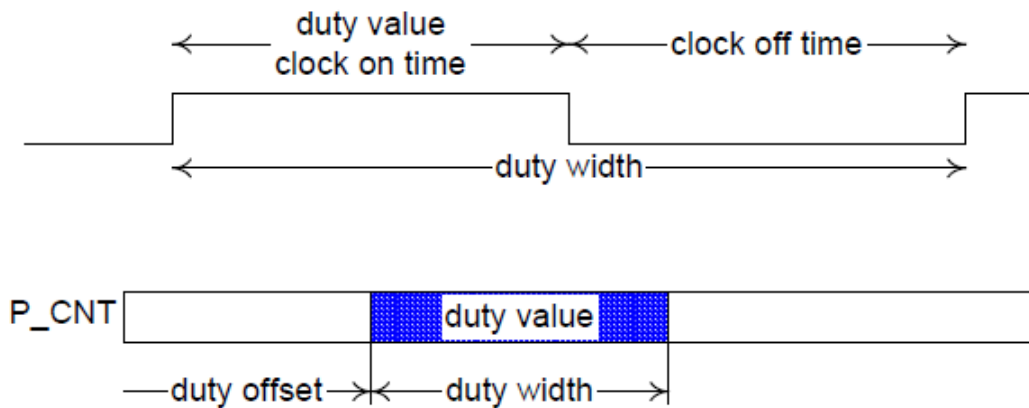

Fig. 8.2: Throttling Example

The FADT contains the duty offset and duty width values. The duty offset value determines the offset within the P_CNT register of the duty value. The duty width value determines the number of bits used by the duty value (which determines the granularity of the throttling logic). The performance of the processor by the clock logic can be expressed with the following equation:

$$\% Performance = \frac{dutysetting}{2^{dutywidth}} * 100\%$$

Fig. 8.3: Equation 1 Duty Cycle Equation

Nominal performance is defined as “close as possible, but not below the indicated performance level.” OSPM will use the duty offset and duty width to determine how to access the duty setting field. OSPM will then program the duty setting based on the thermal condition and desired power of the processor object. OSPM calculates the nominal performance of the processor using the equation expressed in Equation 1. Notice that a dutysetting of zero is reserved. For example, the clock logic could use the stop grant cycle to emulate a divided processor clock frequency on an IA processor (through the use of the STPCLK# signal). This signal internally stops the processor’s clock when asserted LOW. To implement logic that provides eight levels of clock control, the STPCLK# pin could be asserted as follows (to emulate the different frequency settings):

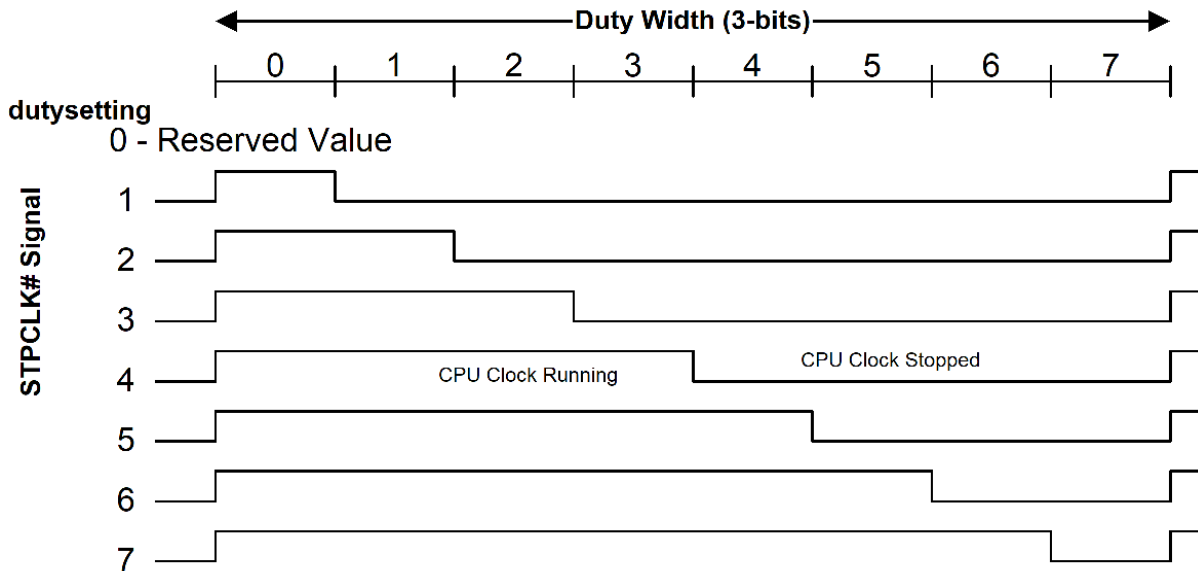

Fig. 8.4: Example Control for the STPCLK

To start the throttling logic OSPM sets the desired duty setting and then sets the THT_EN bit HIGH. To change the duty setting, OSPM will first reset the THT_EN bit LOW, then write another value to the duty setting field while preserving the other unused fields of this register, and then set the THT_EN bit HIGH again.

The example logic model is shown below:

Implementation of the ACPI processor power state controls minimally requires the support a single CPU sleeping state (C1). All of the CPU power states occur in the G0/S0 system state; they have no meaning when the system transitions into the sleeping state(S1-S4). ACPI defines the attributes (semantics) of the different CPU states (defines four of them). It is up to the platform implementation to map an appropriate low-power CPU state to the defined ACPI CPU state.

ACPI clock control is supported through the optional processor register block (P_BLK). ACPI requires that there be a unique processor register block for each CPU in the system. Additionally, ACPI requires that the clock logic for multiprocessor systems be symmetrical when using the P_BLK and FADT interfaces; if the P0 processor supports the C1, C2, and C3 states, but P1 only supports the C1 state, then OSPM will limit all processors to enter the C1 state when idle.

The following sections define the different ACPI CPU sleeping states.

8.1.2 Processor Power State C1

All processors must support this power state. This state is supported through a native instruction of the processor (HLT for IA 32-bit processors), and assumes no hardware support is needed from the chipset. The hardware latency of this state must be low enough that OSPM does not consider the latency aspect of the state when deciding whether to use it. Aside from putting the processor in a power state, this state has no other software-visible effects. In the C1 power state, the processor is able to maintain the context of the system caches.

The hardware can exit this state for any reason, but must always exit this state when an interrupt is to be presented to the processor.

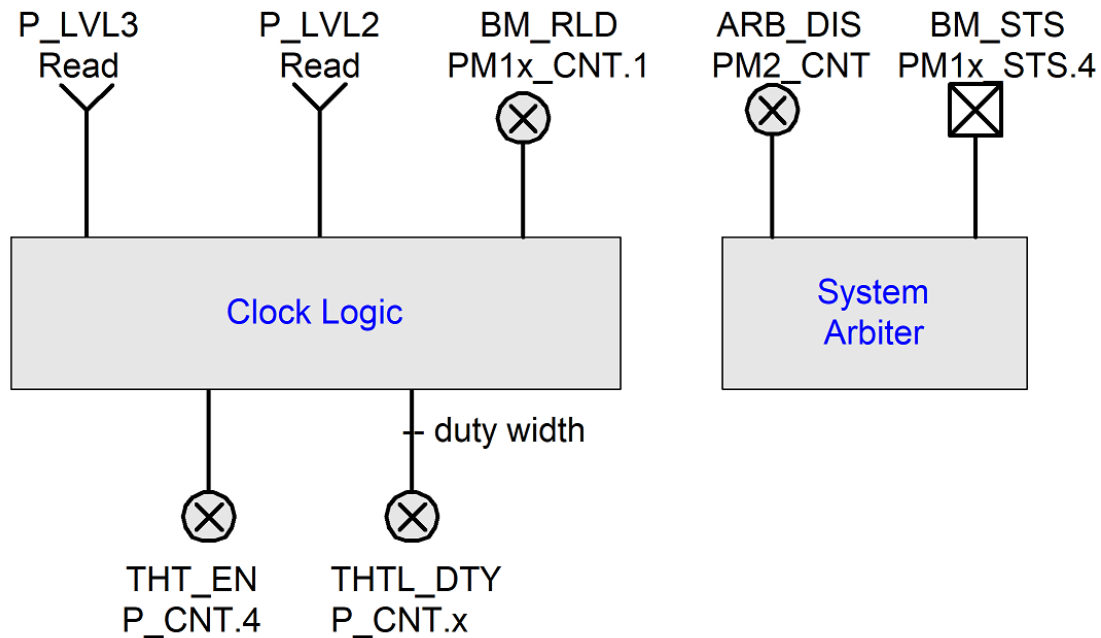

Fig. 8.5: ACPI Clock Logic (One per Processor)

8.1.3 Processor Power State C2

This processor power state is optionally supported by the system. If present, the state offers improved power savings over the C1 state and is entered by using the P_LVL2 command register for the local processor or an alternative mechanism as indicated by the _CST object. The worst-case hardware latency for this state is declared in the FADT and OSPM can use this information to determine when the C1 state should be used instead of the C2 state. Aside from putting the processor in a power state, this state has no other software-visible effects. OSPM assumes the C2 power state has lower power and higher exit latency than the C1 power state.

The C2 power state is an optional ACPI clock state that needs chipset hardware support. This clock logic consists of an interface that can be manipulated to cause the processor complex to precisely transition into a C2 power state. In a C2 power state, the processor is assumed capable of keeping its caches coherent; for example, bus master and multiprocessor activity can take place without corrupting cache context.

The C2 state puts the processor into a low-power state optimized around multiprocessor and bus master systems. OSPM will cause an idle processor complex to enter a C2 state if there are bus masters or Multiple processor activity (which will prevent OSPM from placing the processor complex into the C3 state). The processor complex is able to snoop bus master or multiprocessor CPU accesses to memory while in the C2 state.

The hardware can exit this state for any reason, but must always exit this state whenever an interrupt is to be presented to the processor.

8.1.4 Processor Power State C3

This processor power state is optionally supported by the system. If present, the state offers improved power savings over the C1 and C2 state and is entered by using the P_LVL3 command register for the local processor or an alternative mechanism as indicated by the `_CST` object. The worst-case hardware latency for this state is declared in the FADT, and OSPM can use this information to determine when the C1 or C2 state should be used instead of the C3 state. While in the C3 state, the processor's caches maintain state but the processor is not required to snoop bus master or multiprocessor CPU accesses to memory.

The hardware can exit this state for any reason, but must always exit this state when an interrupt is to be presented to the processor or when `BM_RLD` is set and a bus master is attempting to gain access to memory.

OSPM is responsible for ensuring that the caches maintain coherency. In a uniprocessor environment, this can be done by using the `PM2_CNT.ARB_DIS` bus master arbitration disable register to ensure bus master cycles do not occur while in the C3 state. In a multiprocessor environment, the processors' caches can be flushed and invalidated such that no dynamic information remains in the caches before entering the C3 state.

There are two mechanisms for supporting the C3 power state:

- Having OSPM flush and invalidate the caches prior to entering the C3 state.
- Providing hardware mechanisms to prevent masters from writing to memory (uniprocessor-only support).

In the first case, OSPM will flush the system caches prior to entering the C3 state. As there is normally much latency associated with flushing processor caches, OSPM is likely to only support this in multiprocessor platforms for idle processors. Flushing of the cache is accomplished through one of the defined ACPI mechanisms (described below in *Flushing Caches*).

In uniprocessor-only platforms that provide the needed hardware functionality (defined in this section), OSPM will attempt to place the platform into a mode that will prevent system bus masters from writing into memory while the processor is in the C3 state. This is accomplished by disabling bus masters prior to entering a C3 power state. Upon a bus master requesting an access, the CPU will awaken from the C3 state and re-enable bus master accesses.

OSPM uses the `BM_STS` bit to determine the power state to enter when considering a transition to or from the C2/C3 power state. The `BM_STS` is an optional bit that indicates when bus masters are active. OSPM uses this bit to determine the policy between the C2 and C3 power states: a lot of bus master activity demotes the CPU power state to the C2 (or C1 if C2 is not supported), no bus master activity promotes the CPU power state to the C3 power state. OSPM keeps a running history of the `BM_STS` bit to determine CPU power state policy.

The last hardware feature used in the C3 power state is the `BM_RLD` bit. This bit determines if the Cx power state is exited as a result of bus master requests. If set, then the Cx power state is exited upon a request from a bus master. If reset, the power state is not exited upon bus master requests. In the C3 state, bus master requests need to transition the CPU back to the C0 state (as the system is capable of maintaining cache coherency), but such a transition is not needed for the C2 state. OSPM can optionally set this bit when using a C3 power state, and clear it when using a C1 or C2 power state.

8.1.5 Additional Processor Power States

ACPI introduced optional processor power states beyond C3 starting in ACPI 2.0. These power states, C4... Cn, are conveyed to OSPM through the `_CST` object defined in *_CST (C States)*. These additional power states are characterized by equivalent operational semantics to the C1 through C3 power states, as defined in the previous sections, but with different entry/exit latencies and power savings. See *_CST (C States)* for more information.

8.2 Flushing Caches

To support the C3 power state without using the ARB_DIS feature, the hardware must provide functionality to flush and invalidate the processors' caches (for an IA processor, this would be the WBINVD instruction). To support the S1, S2 or S3 sleeping states, the hardware must provide functionality to flush the platform caches. Flushing of caches is supported by one of the following mechanisms:

- Processor instruction to write back and invalidate system caches (WBINVD instruction for IA processors).
- Processor instruction to write back but not invalidate system caches (WBINVD instruction for IA processors and some chipsets with partial support; that is, they don't invalidate the caches).

The ACPI specification expects all platforms to support the local CPU instruction for flushing system caches (with support in both the CPU and chipset), and provides some limited "best effort" support for systems that don't currently meet this capability. The method used by the platform is indicated through the appropriate FADT fields and flags indicated in this section.

ACPI specifies parameters in the FADT that describe the system's cache capabilities. If the platform properly supports the processor's write back and invalidate instruction (WBINVD for IA processors), then this support is indicated to OSPM by setting the WBINVD flag in the FADT.

If the platform supports neither of the first two flushing options, then OSPM can attempt to manually flush the cache if it meets the following criteria:

- A cache-enabled sequential read of contiguous physical memory of not more than 2 MB will flush the platform caches.
- There are two additional FADT fields needed to support manual flushing of the caches:
- FLUSH_SIZE, typically twice the size of the largest cache in the system.
- FLUSH_STRIDE, typically the smallest cache line size in the system.

8.3 Power, Performance, and Throttling State Dependencies

Cost and complexity trade-off considerations have driven into the platform control dependencies between logical processors when entering power, performance, and throttling states. These dependencies exist in various forms in multi-processor, multi-threaded processor, and multi-core processor-based platforms. These dependencies may also be hierarchical. For example, a multi-processor system consisting of processors containing multiple cores containing multiple threads may have various dependencies as a result of the hardware implementation.

Unless OSPM is aware of the dependency between the logical processors, it might lead to scenarios where one logical processor is implicitly transitioned to a power, performance, or throttling state when it is unwarranted, leading to incorrect / non-optimal system behavior. Given knowledge of the dependencies, OSPM can coordinate the transitions between logical processors, choosing to initiate the transition when doing so does not lead to incorrect or non-optimal system behavior. This OSPM coordination is referred to as Software (SW) Coordination. Alternately, it might be possible for the underlying hardware to coordinate the state transition requests on multiple logical processors, causing the processors to transition to the target state when the transition is guaranteed to not lead to incorrect or non-optimal system behavior. This scenario is referred to as Hardware (HW) coordination. When hardware coordinates transitions, OSPM continues to initiate state transitions as it would if there were no dependencies. However, in this case it is required that hardware provide OSPM with a means to determine actual state residency so that correct / optimal control policy can be realized.

Platforms containing logical processors with cross-processor dependencies in the power, performance, or throttling state control areas use ACPI defined interfaces to group logical processors into what is referred to as a dependency domain. The Coordination Type characteristic for a domain specifies whether OSPM or underlying hardware is responsible for the coordination. When OSPM coordinates, the platform may require that OSPM transition ALL (0xFC)

or ANY ONE (0xFD) of the processors belonging to the domain into a particular target state. OSPM may choose at its discretion to perform coordination even though the underlying hardware supports hardware coordination. In this case, OSPM must transition all logical processors in the dependency domain to the particular target state.

Table 8.1: C-state/T-state/P-state Coordination Types

Value	Description
0xFC	SW_ALL: The OSPM coordinates the state for all processors in the domain by making the same state request on the control interface of each processor in the domain. ALL refers to the requirement that all processors in the domain must agree on the requested state for the domain to enter that state.
0xFD	SW_ANY: The OSPM coordinates the state for all processors in the domain by making a state request on the control interface of only one processor in the domain. ANY refers to the hardware requirement for all processors in the domain to transition to the last requested state on any processor in the domain.
0xFE	HW_ALL: As the OSPM requests a state transition on the control interface of any processor in the domain, hardware coordinates the state for all processors in the domain and transitions all processors in the domain to the coordinated state. ALL refers to the requirement for hardware maintaining coordination as OSPM makes independent state requests on any processor in the domain. Unlike SW_ALL, OSPM can make different state requests for processors in the domain, while hardware determines the resulting state for all processors in the domain. Note: The hardware coordination policy is implementation-defined.

There are no dependencies implied between a processor's C-states, P-states or T-states. Hence, for example it is possible to use the same dependency domain number for specifying dependencies between P-states among one set of processors and C-states among another set of processors without any dependencies being implied between the P-State transitions on a processor in the first set and C-state transitions on a processor in the second set.

8.4 Declaring Processors

Each processor in the system must be declared in the ACPI namespace in the _SB scope. A **Device** definition for a processor is declared using the ACPI0007 hardware identifier (HID). Processor configuration information is provided exclusively by objects in the processor device's object list.

When the platform uses the APIC interrupt model, UID object values under a processor device are used to associate processor devices with entries in the MADT.

Processor-specific objects may be declared within the processor device's scope. These objects serve multiple purposes including processor performance state control. Other ACPI-defined device-related objects are also allowed under the processor device's scope (for example, the unique identifier object _UID mentioned above).

With device-like characteristics attributed to processors, it is implied that a processor device driver will be loaded by OSPM to, at a minimum, process device notifications. OSPM will enumerate processors in the system using the ACPI Namespace, processor-specific native identification instructions, and the _HID method.

For more information on the declaration of the processor device object, see *Device (Declare Device Package)*. Processor-specific child objects are described in the following sections.

ACPI 6.0 introduces the notion of processor containers. Processor containers are declared using the *Processor Container Device*. A processor container can be used to describe a collection of associated processors that share common resources, such as shared caches, and which have power states that affect the processors in the collection. For more information see *Processor Container Device*.

8.4.1 Processor Power State Control

ACPI defines multiple processor power state (C state) control interfaces. These are:

1. The Processor Register Block's (P_BLK's) P_LVL2 and P_LVL3 registers coupled with FADT P_LVLx_LAT values and
2. The _CST object in the processor's object list.
3. The _LPI objects for processors and processor containers.

P_BLK based C state controls are described in *ACPI Hardware Specification*. _CST based C state controls expand the functionality of the P_BLK based controls allowing the number and type of C states to be dynamic and accommodate CPU architecture specific C state entry and exit mechanisms as indicated by registers defined using the Functional Fixed Hardware address space.

_CST is an optional object that provides:

- The Processor Register Block's (P_BLK's) P_LVL2 and P_LVL3 registers coupled with FADT P_LVLx_LAT values.
- The _CST object in the processor's object list.

ACPI 6.0 introduces _LPI, the low power idle state object. _LPI provides more detailed power state information and can describe idle states at multiple levels of hierarchy in conjunction with Processor Containers. See *_LPI (Low Power Idle States)* for details.

8.4.1.1 _CST (C States)

_CST is an optional object that provides an alternative method to declare the supported processor power states (C States). Values provided by the _CST object override P_LVLx values in P_BLK and P_LVLx_LAT values in the FADT. The _CST object allows the number of processor power states to be expanded beyond C1, C2, and C3 to an arbitrary number of power states. The entry semantics for these expanded states, (in other words), the considerations for entering these states, are conveyed to OSPM by the C state Type field and correspond to the entry semantics for C1 C2 and C3 as described in [Section 8.1.2](#) through [Section 8.1.4](#). _CST defines ascending C-states characterized by lower power and higher entry/exit latency.

Arguments:

None

Return Value:

A variable-length Package containing a list of C-state information **Packages** as described below

Return Value Information

_CST returns a variable-length **Package** that contains the following elements:

- Count An **Integer** that contains the number of CState sub-packages that follow
- CStates[] A list of **Count** CState sub-packages

```
Package {
    Count                // Integer
    CStates[0]          // Package
    ...
    CStates[Count-1]    // Package
}
```

Each fixed-length Cstate sub-Package contains the elements described below:

```

Package {
    Register          // Buffer (Resource Descriptor)
    Type              // Integer (BYTE)
    Latency           // Integer (WORD)
    Power             // Integer (DWORD)
}
    
```

Table 8.2: Cstate Package Values

Element	Object Type	Description
Register	Buffer	Contains a Resource Descriptor with a single Register() descriptor that describes the register that OSPM must read to place the processor in the corresponding C state.
Type	Integer (BYTE)	The C State type (1=C1, 2=C2, 3=C3). This field conveys the semantics to be used by OSPM when entering/exiting the C state. Zero is not a valid value.
Latency	Integer (WORD)	The worst-case latency to enter and exit the C State (in microseconds). There are no latency restrictions.
Power	Integer (DWORD)	The average power consumption of the processor when in the corresponding C State (in milliwatts).

The platform must expose a `_CST` object for either all or none of its processors. If the `_CST` object exists, OSPM uses the C state information specified in the `_CST` object in lieu of `P_LVL2` and `P_LVL3` registers defined in `P_BLK` and the `P_LVLx_LAT` values defined in the `FADT`. Also notice that if the `_CST` object exists and the `_PTC` object does not exist, OSPM will use the Processor Control Register defined in `P_BLK` and the `C_State_Register` registers in the `_CST` object.

The platform may change the number or type of C States available for OSPM use dynamically by issuing a **Notify** event on the processor object with a notification value of `0x81`. This will cause OSPM to re-evaluate any `_CST` object residing under the processor object notified. For example, the platform might notify OSPM that the number of supported C States has changed as a result of an asynchronous AC insertion / removal event.

The platform must specify unique `C_State_Register` addresses for all entries within a given `_CST` object.

`_CST` eliminates the ACPI 1.0 restriction that all processors must have C State parity. With `_CST`, each processor can have its own characteristics independent of other processors. For example, processor 0 can support C1, C2 and C3, while processor 1 supports only C1.

The fields in the processor structure remain for backward compatibility.

Example

```

Processor (
    \_SB.CPU0,          // Processor Name
    1,                  // ACPI Processor number
    0x120,              // PBlk system IO address
    6                   // PBlkLen
)
{
    Name(_CST, Package()
    {
        4, // There are four C-states defined here with three semantics
        // The third and fourth C-states defined have the same C3 entry semantics
        Package() {ResourceTemplate() {Register(FixedHW, 0, 0, 0)}, 1, 20, 1000},
        Package() {ResourceTemplate() {Register(SystemIO, 8, 0, 0x161)}, 2, 40, 750},
        Package() {ResourceTemplate() {Register(SystemIO, 8, 0, 0x162)}, 3, 60, 500},
        Package() {ResourceTemplate() {Register(SystemIO, 8, 0, 0x163)}, 3, 100, 250}
    }
}
    
```

(continues on next page)

(continued from previous page)

```
)
}
```

Notice in the example above that OSPM should anticipate the possibility of a `_CST` object providing more than one entry with the same `C_State_Type` value. In this case OSPM must decide which `C_State_Register` it will use to enter that C state.

Example

This is an example usage of the `_CST` object using the typical values as defined in ACPI 1.0.

```
Processor (
  \_SB.CPU0,          // Processor Name
  1,                  // ACPI Processor number
  0x120,              // PBLK system IO address
  6 )                 // PBLK Len
{
  Name(_CST, Package()
  {
    2,                // There are two C-states defined here - C2 and C3
    Package() {ResourceTemplate() {Register(SystemIO, 8, 0, 0x124)}, 2, 2, 750},
    Package() {ResourceTemplate() {Register(SystemIO, 8, 0, 0x125)}, 3, 65, 500}
  })
}
```

The platform will issue a **Notify** (`_SB.CPU0, 0x81`) to inform OSPM to re-evaluate this object when the number of available processor power states changes.

8.4.1.2 `_CSD` (C-State Dependency)

This optional object provides C-state control cross logical processor dependency information to OSPM. The `_CSD` object evaluates to a packaged list of information that correlates with the C-state information returned by the `_CST` object. Each packaged list entry identifies the C-state for which the dependency is being specified (as an index into the `_CST` object list), a dependency domain number for that C-state, the coordination type for that C-state and the number of logical processors belonging to the domain for the particular C-state. It is possible that a particular C-state may belong to multiple domains. That is, it is possible to have multiple entries in the `_CSD` list with the same `CStateIndex` value.

Arguments:

None

Return Value:

A variable-length `Package` containing a list of C-state dependency `Packages` as described below.

Return Value Information

```
Package {
  CStateDependency[0]    // Package
  ...
  CStateDependency[n]    // Package
}
```

Each `CstateDependency` sub-`Package` contains the elements described below:

```
Package {
    NumEntries          // Integer
    Revision            // Integer (BYTE)
    Domain              // Integer (DWORD)
    CoordType           // Integer (DWORD)
    NumProcessors       // Integer (DWORD)
    Index              // Integer (DWORD)
}
```

Table 8.3: C-State Dependency Package Values

Element	Object Type	Description
NumEntries	Integer	The number of entries in the CStateDependency package including this field. Current value is 6.
Revision	Integer (BYTE)	The revision number of the CStateDependency package format. Current value is 0.
Domain	Integer (DWORD)	The dependency domain number to which this C state entry belongs.
CoordType	Integer (DWORD)	See Table 8.1 for supported C-state coordination types.
Num Processors	Integer (DWORD)	The number of processors belonging to the domain for the particular C-state. OSPM will not start performing power state transitions to a particular C-state until this number of processors belonging to the same domain for the particular C-state have been detected and started.
Index	Integer (DWORD)	Indicates the index of the C-State entry in the _CST object for which the dependency applies.

Given that the number or type of available C States may change dynamically, ACPI supports Notify events on the processor object, with Notify events of type 0x81 causing OSPM to re-evaluate any _CST objects residing under the particular processor object notified. On receipt of Notify events of type 0x81, OSPM should re-evaluate any present _CSD objects also.

Example

This is an example usage of the _CSD structure in a Processor structure in the namespace. The example represents a two processor configuration. The C1-type state can be independently entered on each processor. For the C2-type state, there exists dependence between the two processors, such that one processor transitioning to the C2-type state, causes the other processor to transition to the C2-type state. A similar dependence exists for the C3-type state. OSPM will be required to coordinate the C2 and C3 transitions between the two processors. Also OSPM can initiate a transition on either processor to cause both to transition to the common target C-state.

```
Processor (
    \_SB.CPU0,          // Processor Name
    1,                  // ACPI Processor number
    0x120,              // PBlk system IO address
    6 )                 // PBlkLen
{
    Name (_CST, Package()
    {
        3,              // There are three C-states defined here with_
        ↪three semantics
        Package() {ResourceTemplate() {Register(FixedHW, 0, 0, 0)}, 1, 20, 1000},
        Package() {ResourceTemplate() {Register(SystemIO, 8, 0, 0x161)}, 2, 40, 750},
        Package() {ResourceTemplate() {Register(SystemIO, 8, 0, 0x162)}, 3, 60, 500}
    })
}
```

(continues on next page)

(continued from previous page)

```

Name (_CSD, Package()
{
    Package() {6, 0, 0, 0xFD, 2, 1} , // 6 entries, Revision 0, Domain 0, OSPM Coordinate
                                        // Initiate on Any Proc, 2 Procs, Index 1 (C2-type)
    Package() {6, 0, 0, 0xFD, 2, 2} // 6 entries, Revision 0, Domain 0, OSPM Coordinate
                                        // Initiate on Any Proc, 2 Procs, Index 2 (C3-type)
})
}
Processor (
    \_SB.CPU1, // Processor Name
    2, // ACPI Processor number
    , // PBlk system IO address
    ) // PBlkLen
{
Name (_CST, Package()
{
    3, // There are three C-states defined here with three semantics
    Package() {ResourceTemplate() {Register(FixedHW, 0, 0, 0)}, 1, 20, 1000},
    Package() {ResourceTemplate() {Register(SystemIO, 8, 0, 0x161)}, 2, 40, 750},
    Package() {ResourceTemplate() {Register(SystemIO, 8, 0, 0x162)}, 3, 60, 500}
})
Name (_CSD, Package()
{
    Package() {6, 0, 0, 0xFD, 2, 1}, // 6 entries, Revision 0, Domain 0, OSPM Coordinate
                                        // Initiate on any Proc, 2 Procs, Index 1 (C2-type)
    Package() {6, 0, 0, 0xFD, 2, 2} // 6 entries, Revision 0, Domain 0, OSPM Coordinate
                                        // Initiate on any Proc, 2 Procs, Index 2 (C3-type)
})
}
}

```

When the platform issues a **Notify** (_SB.CPU0, 0x81) to inform OSPM to re-evaluate _CST when the number of available processor power states changes, OSPM should also evaluate _CSD.

8.4.2 Processor Hierarchy

It is very typical for computing platforms to have a multitude of processors that share common resources, such as caches, and which have common power states that affect groups of processors. These are arranged in a hierarchical manner. For example, a system may contain a set of NUMA nodes, each with a number of sockets, which may contain multiple groups of processors, each of which may contain individual processor cores, each of which may contain multiple hardware threads. Different architectures use different terminology to denominate logically associated processors, but terms such as package, cluster, module, and socket are typical examples. ACPI uses the term processor container to describe a group of associated processors. Processors are said to belong to a container if they are associated in some way, such as a shared cache or a low power mode which affects them all.

The figure above depicts an example system, which comprises a system level processor container, which in turn contains two cluster processor containers, each of which contains two processors. The overall collection is called the processor hierarchy and standard tree terminology is used to refer to different parts of it. For example, an individual processor or container is called a node, the nodes which reside within a processor container are called children of that parent, etc. This example is symmetric but that is not a requirement. For example, a system may contain a different number of processors in different containers or an asymmetric hierarchy where one side of the topology tree is deeper than another. Also note that while this example includes a single top level processor container encompassing all processors, this is not a requirement. It is legal for a system to be described using a collection of trees. (*See Note below*)

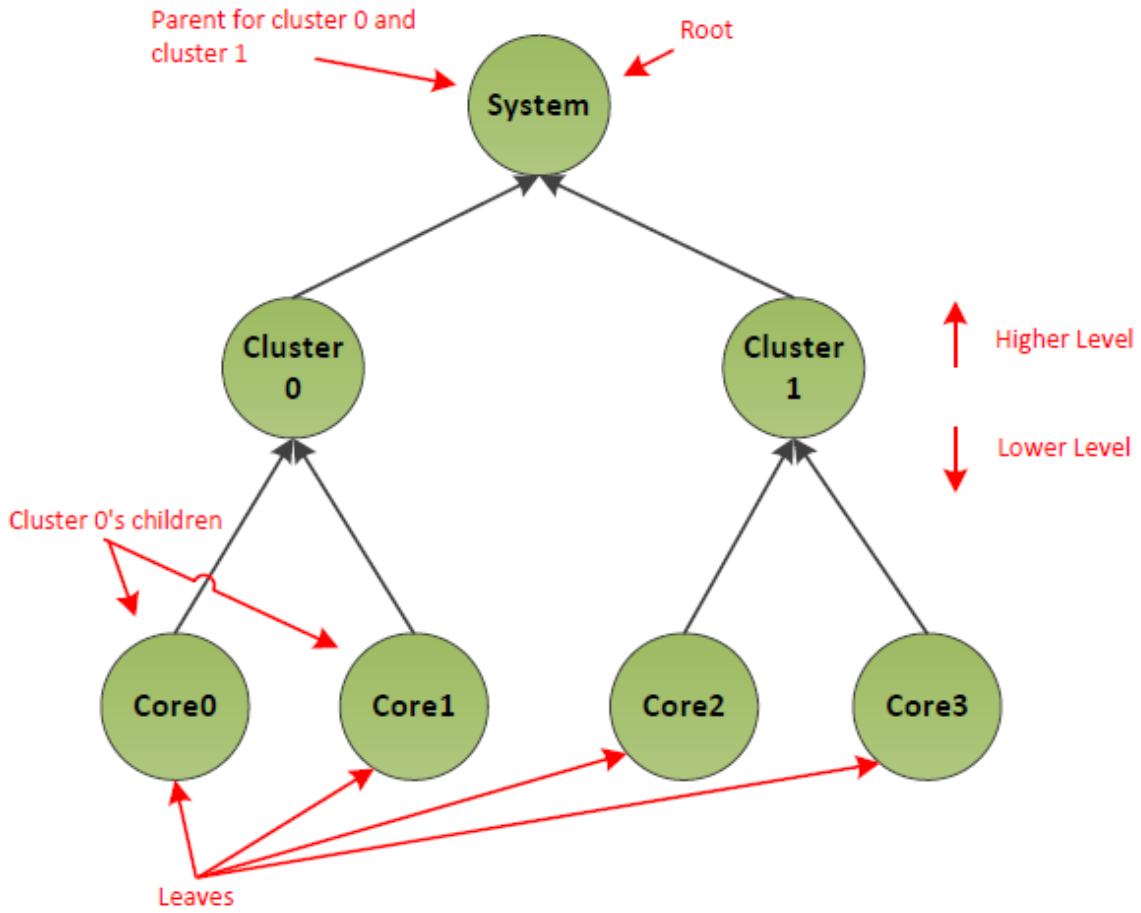

Fig. 8.6: Processor Hierarchy

Note: The processor hierarchy can be used to describe a number of different characteristics of system topology. The main example is shared power states, see the Low Power Idle states in *Lower Power Idle States* for details.

8.4.2.1 Processor Container Device

This optional device is a container object that acts much like a bus node in a namespace. It may contain child objects that are either processor devices or other processor containers. This allows representing hierarchical processor topologies. Each processor container or processor in the hierarchy is herein referred to as a node. The processor container device is declared using the hardware identifier (_HID) ACPI0010.

To aid support of operating systems which do not parse processor containers, a container can carry a Compatible ID (_CID) of PNP0A05, which represents a generic container device (see *Device Class-Specific Objects*)

A processor container declaration must supply a _UID method returning an ID that is unique in the processor container hierarchy. A processor container must contain either other processor containers or other processor devices declared within its scope. In addition, a processor container may also contain the following methods in its scope:

Table 8.4: **Processor Container Device Objects**

Object	Description
_LPI	Declares local power states for the hierarchy node represented by the processor container
_RDI	Declares power resource dependencies that affect system level power states
_STA	Determines the status of a processor container. See Device Class-Specific Objects.

_LPI may be present under a processor device, and is described in *_LPI (Low Power Idle States)*. RDI can only be present under a singular top level processor container object, and is described below.

ACPI allows the definition of more than one root level processor container. In other words, it is possible to define multiple top level containers. For example, in a NUMA system if there are no idle states or other objects that need to be encapsulated at the system level, multiple NUMA-node level processor containers may be defined at the top level of the hierarchy.

Processor Container Device objects are only valid for implementations conforming to ACPI 6.0 or higher. A platform can ascertain whether an operating system supports parsing of processor container objects via the _OSC method (see *Platform-Wide OSPM Capabilities*).

8.4.3 Lower Power Idle States

ACPI 6.0 introduces Lower Power Idle states (LPI). This extends the specification to allow expression of idle states that, like C-states, are selected by the OSPM when a processor goes idle, but which may affect more than one processor, and may affect other system components. LPI extensions in the specification leverage the processor container device, and in this way can express which parts of the system are affected by a given LPI state.

LPI states are defined via the following objects:

- _LPI objects define the states themselves, and may be declared inside a processor or a processor container device
- _RDI allows expressing constraints on LPI usage borne out of device usage

8.4.3.1 Hierarchical Idle States

Processor containers (*Processor Container Device*) can be used in conjunction with `_LPI` (*_LPI (Low Power Idle States)*) to describe idle states in a hierarchical manner. Within the processor hierarchy, each node has low power states that are specific to that node. ACPI refers to states that are specific to a node in the hierarchy as Local Power States. For example in the system depicted in *Power states for processor hierarchy*, the local power states of CPU0 are clock gate, retention and power down.

When the OS running on a given processor detects there is no more work to schedule on that processor, it needs to select an idle state. The state may affect more than just that processor. A processor going idle could be the last one in the system, or in a processor container, and therefore may select a power state what affects multiple processors. In order to select such a state, the OS needs to choose a local power state for each affected level in the processor hierarchy.

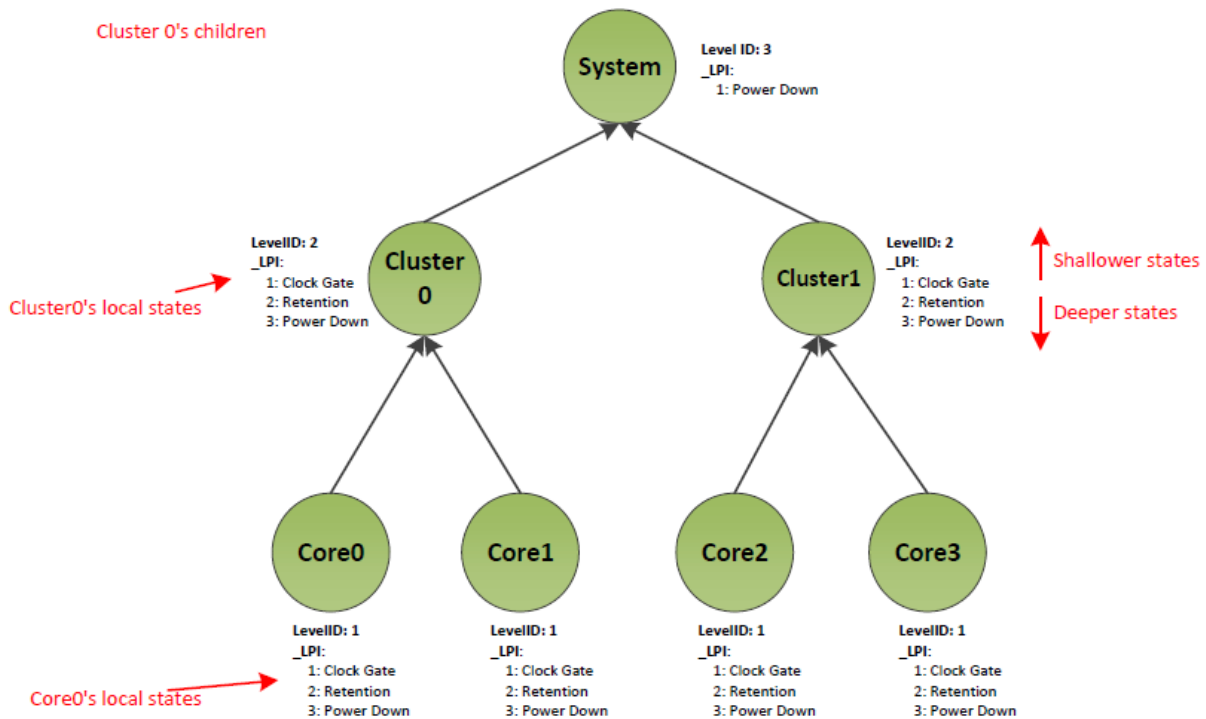

Fig. 8.7: Power states for processor hierarchy

Consider a situation where Core 0 is the last active core depicted in the example system, *Power states for processor hierarchy*. It may put the system into the lowest possible idle state. To do so, the OS chooses local state 3 (Power Down) for Core 0, local state 3 (Power Down) for Cluster 0, and local state 1 (Power Down) for the system. However, most HW architectures only support a single power state request from the OS to the platform. That is, it is not possible to make a separate local power state request per hierarchy node to the platform. Therefore, the OS must combine the per level local power states into a single Composite power state. The platform then acts on the Composite power state request.

A platform can only support a limited set of Composite power states, and not every combination of Local Power states across levels is valid. The valid power states in our example system are depicted in the following table.

Table 8.5: Valid Local State Combinations in preceding example system

System Level Processor Container	Cluster level Processor Container	Processor
Running	Running	Clock Gated
Running	Running	Retention
Running	Running	Power Down
Running	Clock Gated	Clock Gated
Running	Clock Gated	Retention
Running	Clock Gated	Power Down
Running	Retention	Retention
Running	Retention	Power Down
Running	Power Down	Power Down
Power Down	Power Down	Power Down

8.4.3.2 Idle State Coordination

With hierarchical idle states, multiple processors affect the idle state for any non-leaf hierarchy node. Taking our example system in *Power states for processor hierarchy*, for cluster 0 to enter a low power state, both Core 0 and Core 1 must be idle. In addition, the power state selection done for Core 0 and Core 1 as they go idle has bearing on the state that can be used for Cluster 0. This requires coordination of idle state requests between the two processors. ACPI supports two different coordination schemes (detailed in subsections following):

- Platform coordinated
- OS initiated.

The OS and the platform can handshake on support for OS Initiated Idle or Platform Coordinated Idle using the `_OSC` method as described in *Platform-Wide OSPM Capabilities*. Note that an Architecture specific command may be required to enter OS Initiated mode, in which case please refer to architecture specific documentation. (For PSCI documentation see <http://uefi.org/acpi> under the heading “PSCI Specification”; for ARM FFH documentation, see <http://uefi.org/acpi> under the heading “ARM FFH Specification”.)

8.4.3.2.1 Platform Coordinated

With the Platform Coordinated scheme, the platform is responsible for coordination of idle states across processors. OSPM makes a request for all levels of hierarchy from each processor meaning that each processor makes a vote by requesting a local power state for itself, its parent, its parent’s parent, etc. (In some cases, the vote for a particular hierarchy level may be implicit - see the autopromotion discussion below for more details). When choosing idle states at higher levels, the OSPM on a processor may opt to keep a higher level node in a running state - this is still a vote for that node which the platform must respect. The vote expressed by the OSPM sets out the constraints on the local power state that the platform may choose for processor, and any parent nodes affected by the vote. In particular the vote expresses that the platform must not enter:

1. A deeper (lower power) local state than the requested one.
2. A local power state with a higher wake up latency than the requested one.
3. A local power state with power resource dependencies that the requested state does not have.

The platform looks across the votes for each hierarchy node from all underlying cores and chooses the deepest local state which satisfies all of the constraints associated with all of the votes. Normally, this just means taking the shallowest state that one of the cores voted for, since shallower states have lower wakeup latencies, lower minimum residencies, and fewer power resource dependencies. However, this may not always be the true, as state depth and latencies do not always increase together. For the sake of efficiency, the platform should generally not enter a power state with a higher minimum residency than the requested one. However, this is not a strict functional requirement.

The platform may resolve to a state with higher minimum residency if it believes that is the most efficient choice based on the specific states and circumstances.

Using the above example in *Power states for processor hierarchy*, a simple flow would look like this:

- Core0 goes idle - OS requests Core0 Power Down, Cluster0 Retention
- Platform receives Core0 requests - place Core0 in the Power Down state
- Core1 goes idle - OS requests Core1 Power Down, Cluster0 Power Down
- Platform receives Core1 request - puts Core1 in the Power Down state, and takes shallowest vote for Cluster0, thus placing it into the Retention state

If the OSPM wanted to request power states beyond the cluster level, then Core0 and Core1 would both vote for an idle state at System level too, and the platform would resolve the final state selection across their votes and votes from any other processors under the System hierarchy via the method described above.

As mentioned above, certain platforms support a mechanism called autopromotion where the votes for higher level states may be implicit rather than explicit. In this scheme, the platform provides OSPM with commands to request idle states at a lower level of the processor hierarchy which automatically imply a specific idle state request at the respective higher level of the hierarchy. There is no command to explicitly request entry into the higher level state, only the implicit request based on the lower level state.

For example, if the platform illustrated in *Power states for processor hierarchy* uses autopromotion for the Cluster0 Clock Gated state, neither Core0 nor Core1 can explicitly request it. However, a core level Clock Gate request from either Core0 or Core1 would imply a Cluster0 Clock Gate request. Therefore, if both cores request core clock gating (or deeper), Cluster0 will be clock gated automatically by the platform. Additional details on how autopromotion is supported by ACPI can be found in *Entry Method and Composition*.

8.4.3.2.2 OS Initiated

In the OS Initiated coordination scheme, OSPM only requests an idle state for a particular hierarchy node when the last underlying processor goes to sleep. Obviously a processor always selects an idle state for itself, but idle states for higher level hierarchy nodes like clusters are only selected when the last processor in the cluster goes idle. The platform only considers the most recent request for a particular node when deciding on its idle state.

The main motivations for OS Initiated coordination are:

1. Avoid overhead of OSPM evaluating selection for higher level idle states which will not be used since other processors are still awake
2. Allow OSPM to make higher level idle state selections based on the latest information by taking only the most recent request for a particular node and ignoring requests from processors which went to sleep in the past (and may have been based on information which is now stale)

Using the above example in a simple flow would look like the following.

Table 8.6: OS Initiated Flow

Step		OS View of power states	Platform view of power states
0:	Cores 0 and 1 are both awake and running code	Core0: Running Core1: Running Cluster0: Running	Core0: Running Core1: Running Cluster0: Running
1	OS on Core0 requests Core0 PowerDown	Core0: PowerDown Core1: Running Cluster0: Running	Core0: Running Core1: Running Cluster0: Running

continues on next page

Table 8.6 – continued from previous page

Step		OS View of power states	Platform view of power states
2	Platform observes request and places Core0 into power down	Core0: PowerDown Core1: Running Cluster0: Running	Core0: PowerDown Core1: Running Cluster0: Running
3	OS on Core1 requests Core1 PowerDown and Cluster0 PowerDown	Core0: PowerDown Core1: PowerDown Cluster0: PowerDown	Core0: PowerDown Core1: Running Cluster0: Running
4	Platform observes requests for Core1 and Cluster0 and processes them	Core0: PowerDown Core1: PowerDown Cluster0: PowerDown	Core0: PowerDown Core1: PowerDown Cluster0: PowerDown

Note that Core1 is making a cluster decision which affects both Core0 and Core1 so OSPM should consider expected sleep duration, wake up latency requirements, device dependencies, etc. for both cores and not just Core1 when requesting the cluster state.

The platform is still responsible for ensuring functional correctness. For example, if Core0 wakes back up, the cluster state requested by Core1 in the above example should be exited or the entry into the state should be aborted. OSPM has no responsibility to guarantee that the last core down is also the first core up, or that a core does not wake up just as another is requesting a higher level sleep state.

8.4.3.2.2.1 OS Initiated Request Semantics

With OS Initiated coordination, the ordering of requests from different cores is critically important since the platform acts upon the latest one. If the platform does not process requests in the order the OS intended then it may put the platform into the wrong state. Consider this scenario in our example system in *Power states for processor hierarchy*, as shown in the following table.

Table 8.7: Example of incorrect platform state in OS Initiated Request without Dependency Check

Step		OS View of power states	Platform view of power states
0:	Core0 in PowerDown, and Core1 is running	Core0: PowerDown Core1: Running Cluster0: Running	Core0: PowerDown Core1: Running Cluster0: Running
1	Core1 goes idle – the OSPM requests Core1 PowerDown and Cluster0 Retention	Core0: PowerDown Core1: PowerDown Cluster0: Retention	Core0: PowerDown Core1: Running Cluster0: Running
2	Core0 receives an interrupt and wakes up into platform	Core0: PowerDown Core1: PowerDown Cluster0: Retention	Core0: Running Core1: Running Cluster0: Running
3	Core0 moves into OSPM and starts processing interrupt	Core0: Running Core1: PowerDown Cluster0: Running	Core0: Running Core1: Running Cluster0: Running
4	Core0 goes idle and OSPM request Core0 Power Down, Cluster0 Power Down	Core0: PowerDown Core1: PowerDown Cluster0: PowerDown	Core0: Running Core1: Running Cluster0: Running
5	Core0's idle request "passes" Core1's request. Platform puts Core0 to Power Down but ignores cluster request since Core1 is still running	Core0: PowerDown Core1: PowerDown Cluster0: PowerDown	Core0: PowerDown Core1: Running Cluster0: Running

continues on next page

Table 8.7 – continued from previous page

Step		OS View of power states	Platform view of power states
6	Core1's request is observed by the platform. Platform puts Core1 to Power Down and Cluster0 to retention.	Core0: PowerDown Core1: PowerDown Cluster0: PowerDown!! (See Note below)	Core0: PowerDown Core1: PowerDown Cluster0: Retention!! (See Note below)

Note: In the last row of the table above, the Cluster0 values are mismatched.

The key issue here is the race condition between the requests from the two cores; there is no guarantee that they reach the platform in the same order the OS made them. It is not expected to be common, but Core0's request could "pass" Core1's for a variety of potential reasons - lower frequency, different cache behavior, handling of some non-OS visible event, etc. This sequence of events results in the platform incorrectly acting on the stale Cluster0 request from Core1 rather than the latest request from Core0. The net result is that Cluster0 is left in the wrong state until the next wakeup.

To address such race conditions and ensure that the platform and OS have a consistent view of the request ordering, OS Initiated idle state request semantics are enhanced to include a hierarchical dependency check. When the platform receives a request, it is responsible for checking whether the requesting core is really the last core down in the requested domain and rejecting the request if not. Note that even if OSPM and the platform are behaving correctly, they may not always agree on the state of the system due to various races. For example, the platform may see a core waking up before OSPM, and therefore see that core as running, whilst the OSPM still sees it as sleeping. The platform can start treating a particular core as being in a low power state, for the sake of the dependency check, once it has seen the core's request (so that it can be correctly ordered versus other OS requests). The platform must start treating a core as running before returning control to the OS after it wakes up from an idle state.

With this dependency check, the above example would change as follows:

Table 8.8: OS Initiated Request Semantics with Dependency Check

Step:		OS View of power states	Platform view of power states
0-4:	Same as above	Core0: PowerDown Core1: PowerDown Cluster0: PowerDown	Core0: Running Core1: Running Cluster0: Running
5	Core0's idle request "passes" Core1's request. Platform rejects Core0's request since it includes Cluster0 but Core1 is still awake.	Core0: PowerDown Core1: PowerDown Cluster0: PowerDown	Core0: Running Core1: Running Cluster0: Running
6	Core1's request is observed by the platform. Platform rejects Core1's request since it includes Cluster0 but Core0 is still awake.	Core0: PowerDown Core1: PowerDown Cluster0: PowerDown	Core0: Running Core1: Running Cluster0: Running
7	OS resumes on Core0	Core0: Running Core1: PowerDown Cluster0: Running	Core0: Running Core1: Running Cluster0: Running
8	OS resumes on Core1	Core0: Running Core1: Running Cluster0: Running	Core0: Running Core1: Running Cluster0: Running

Once control is returned to the OS, it can handle as it sees fit - likely just re-evaluating the idle state on both cores. When requests are received out of order, some overhead is introduced by rejecting the command and forcing the OS to

re-evaluate, but this is expected to be rare. Requests sent by the OS should be seen by the platform in the same order the vast majority of the time, and in this case, the idle command will proceed as normal.

It is possible that the OS may choose to keep a particular hierarchy node running even if all CPUs underneath it are asleep. This gives rise to another potential corner case - see below.

Table 8.9: Example of incorrect platform state in OS Initiated Request without Hierarchy Parameter

Step		OS View of power states	Platform view of power states
0:	Core0 in PowerDown, and Core1 is running	Core0: PowerDown Core1: Running Cluster0: Running	Core0: PowerDown Core1: Running Cluster0: Running
1	Core1 goes idle – the OSPM OS requests Core1 PowerDown and Cluster0 Retention	Core0: PowerDown Core1: PowerDown Cluster0: Retention	Core0: PowerDown Core1: Running Cluster0: Running
2	Core0 receives an interrupt and wakes up into platform	Core0: PowerDown Core1: PowerDown Cluster0: Retention	Core0: Running Core1: Running Cluster0: Running
3	Core0 moves into OSPM and starts processing interrupt	Core0: Running Core1: PowerDown Cluster0: Running	Core0: Running Core1: Running Cluster0: Running
4	Core0 goes idle and OSPM request Core0 Power Down and requests Cluster0 to stay running	Core0: PowerDown Core1: PowerDown Cluster0: Running	Core0: Running Core1: Running Cluster0: Running
5	Core0's idle request "passes" Core1's request. Platform puts Core0 to PowerDown. Even though the OS made a request for the cluster to run, Platform does not know to reject Core0's request since it doesn't include a Cluster idle state	Core0: PowerDown Core1: PowerDown Cluster0: Running	Core0: PowerDown Core1: Running Cluster0: Running
6	Core1's request is observed by the platform. Platform puts Core1 to Power Down and Cluster0 to retention.	Core0: PowerDown Core1: PowerDown Cluster0: Running!! (See Note, below)	Core0: PowerDown Core1: PowerDown Cluster0: Retention!! (See Note below)

Note: In the last row of the table above, the Cluster0 values are mismatched.

The fundamental issue is that the platform cannot infer what hierarchy level a request is for, based on what levels are being placed into a low power mode. To mitigate this, each idle state command must include a hierarchy parameter specifying the highest level hierarchy node for which the OS is making a request in addition to the normal idle state identifier. Even if the OS does not want some higher level hierarchy node to enter an idle state, it should indicate if the core is the last core down for that node. This allows the platform to understand the OS's view of the state of the hierarchy and ensure ordering of requests even if the OS requests a particular node to stay running.

This enhancement is illustrated in the following table.

Table 8.10: OS Initiated Request Semantics with Hierarchy Parameter

Step		OS View of power states	Platform view of power states
0:	Core0 in PowerDown, and Core1 is running	Core0: PowerDown Core1: Running Cluster0: Running	Core0: PowerDown Core1: Running Cluster0: Running
1	Core1 goes idle – the OSPM OS requests Core1 PowerDown and Cluster0 Retention and identifies itself as last down in Cluster0	Core0: PowerDown Core1: PowerDown Cluster0: Retention	Core0: PowerDown Core1: Running Cluster0: Running
2	Core0 receives an interrupt and wakes up into platform	Core0: PowerDown Core1: PowerDown Cluster0: Retention	Core0: Running Core1: Running Cluster0: Running
3	Core0 moves into OSPM and starts processing interrupt	Core0: Running Core1: PowerDown Cluster0: Running	Core0: Running Core1: Running Cluster0: Running
4	Core0 goes idle and OSPM request Core0 Power Down and requests Cluster0 to stay running and identifies itself as last down in Cluster0	Core0: PowerDown Core1: PowerDown Cluster0: Running	Core0: Running Core1: Running Cluster0: Running
5	Core0's idle request "passes" Core1's request. Platform rejects Core0's request since it is a request for Cluster0 but Core1 is still awake.	Core0: PowerDown Core1: PowerDown Cluster0: PowerDown	Core0: Running Core1: Running Cluster0: Running
6	Core1's request is observed by the platform. Platform rejects Core1's request since it is a request for Cluster0 but Core0 is still awake.	Core0: PowerDown Core1: PowerDown Cluster0: PowerDown	Core0: Running Core1: Running Cluster0: Running
7	OS resumes on Core0	Core0: Running Core1: PowerDown Cluster0: Running	Core0: Running Core1: Running Cluster0: Running
8	OS resumes on Core1	Core0: Running Core1: Running Cluster0: Running	Core0: Running Core1: Running Cluster0: Running

As before, once control is returned to the OS, it can handle as it sees fit - likely just re-requesting the idle state on both cores.

8.4.3.3 _LPI (Low Power Idle States)

_LPI is an optional object that provides a method to describe Low Power Idle states that defines the local power states for each node in a hierarchical processor topology. The OSPM uses the _LPI object to select a local power state for each level of processor hierarchy in the system. These local state selections are then used to produce a composite power state request that is presented to the platform by the OSPM.

This object may be used inside a Processor Container or a processor declaration. _LPI takes the following format:

Arguments:

None

Return Value:

A variable-length **Package** containing the local power states for the parent Processor or Processor Container device as described in the table below. _LPI evaluation returns the following format:

```
Package {
    Revision,           // Integer (WORD)
    LevelID,           // Integer (QWORD)
    Count,             // Integer (WORD)
    LPI[1],            // Package
    ...
    LPI[N]              // Package
}
```

Table 8.11: Local Power States for the Parent Processor or Processor Container

Element	Object Type	Description
Revision	Integer (WORD)	The revision number of the <code>_LPI</code> object. Current revision is 0.
LevelID	Integer (QWORD)	A platform defined number that identifies the level of hierarchy of the processor node to which the LPI states apply. This is used in composition of IDs for OS Initiated states described in Entry Method and Composition. In a platform that only supports platform coordinated mode, this field must be 0.
Count	Integer (WORD)	The count of following LPI packages.
LPI[1]	Package	A Package containing the definition of LPI state 1.
LPI[N]	Package	A Package containing the definition of LPI state N.

Each LPI sub-Package contains the elements described below:

```
Package() {
    Min Residency,           // Integer (DWORD)
    Worst case wakeup latency, // Integer (DWORD)
    Flags,                   // Integer (DWORD)
    Arch. Context Lost Flags, // Integer (DWORD)
    Residency Counter Frequency, // Integer (DWORD)
    Enabled Parent State,    // Integer (DWORD)
    Entry Method,            // Buffer (ResourceDescriptor) or
                            // Integer (QWORD)
    Residency Counter Register // Buffer (ResourceDescriptor)
    Usage Counter Register    // Buffer (ResourceDescriptor)
    State Name                 // String (ASCIIIZ)
}
```

Table 8.12: Extended LPI Fields

Element	Object Type	Description
Min Residency	Integer (DWORD)	Minimum Residency - time in microseconds after which a state becomes more energy efficient than any shallower state. See <i>Power, Minimum Residency, and Worst Case Wakeup Latency</i> .
Worst case wakeup latency	Integer (DWORD)	Worst case time in microseconds from a wake interrupt being asserted to the return to a running state of the owning hierarchy node (processor or processor container). See <i>Power, Minimum Residency, and Worst Case Wakeup Latency</i> .
Flags	Integer (DWORD)	Valid flags are described in <i>Flags for LPI states</i> .

continues on next page

Table 8.12 – continued from previous page

Element	Object Type	Description
Arch. Context Lost Flags	Integer (DWORD)	Architecture specific context loss flags. These flags may be used by a processor architecture to indicate processor context that may be lost by the power state and must be handled by OSPM. See <i>Architecture Specific Context Loss Flags</i> for more details.
Residency Counter Frequency	Integer (DWORD)	Residency counter frequency in cycles-per-second (Hz). Value 0 indicates that counter runs at an architectural-specific frequency. Valid only if a Residency Counter Register is defined.
Enabled Parent State	Integer (DWORD)	Every shallower power state in the parent is also enabled. 0 implies that no local idle states may be entered at the parent node.
Entry Method	Buffer or Integer (QWORD)	This may contain a resource descriptor or an integer. A Resource Descriptor with a single Register() descriptor may be used to describe the register that must be read in order to enter the power state. Alternatively, an integer may be provided in which case the integer would be used in composing the final Register Value that must be used to enter this state. This composition process is described below in <i>Entry Method and Composition</i> .
Residency Counter Register	Buffer	Optional residency counter register which provides the amount of time the owning hierarchy node has been in this local power state. The time is provided in a frequency denoted by the Residency counter frequency field (see above). The register is optional. If the platform does not support it, then the following NULL register descriptor should be used: ResourceTemplate() {Register {(SystemMemory, 0, 0, 0, 0)}} .
Usage Counter Register	Buffer	Optional register that provides the number of times the owning hierarchy node has been in this local power state. If the platform does not support this register, then the following NULL register descriptor should be used: ResourceTemplate() {Register {(SystemMemory, 0, 0, 0, 0)}}
State Name	String (ASCIIZ)	String containing a human-readable identifier of this LPI state. This element is optional and an empty string (a null character) should be used if this is not supported.

Table 8.13: Flags for LPI states

Element	Bits	Description
Enabled	0	1 if the power state is enabled for use 0 if the power state is disabled

It is not required that all processors or processor containers include `_LPI` objects. However, if a processor container includes an `_LPI` object, then all children processors or processor containers must have `_LPI` objects.

The following sections describe the more complex properties of LPI in more detail, as well as rules governing wakeup for LPI states.

8.4.3.3.1 Disabling a State

When a local state is disabled by clearing the Enabled bit in the Flags field, any deeper states for that node are *not* renumbered. This allows other properties which rely on indexing into the state list for that node (Enabled Parent State for example) to not change.

Disabled states should not be requested by the OS and values returned by Residency/Usage Counter Registers are undefined.

8.4.3.3.2 Enabled Parent State

As mentioned above, LPI represent local states, which must be combined into a composite state. However not every combination is possible. Consider the example system described in *Power states for processor hierarchy*. In this system it would not be possible to simultaneously select clock gating as local state for Core0 and power down as local state for Cluster0. As Core0 is physically in Cluster0, power gating the cluster would imply power gating the core. The correct combinations of local states for this example system are described in *Valid Local State Combinations in preceding example system*. LPI states support enumeration of the correct combinations through the Enabled Parent State (EPS) property.

LPI States are 1-indexed. Much like C and S states, LPI0 is considered to be a running state. For a given LPI, the EPS is a 1-based index into the processor containers' _LPI states. The index points at the deepest local power state of the parent processor that the given LPI state enables. Every shallower power state in the parent is also enabled. Taking the system described in Fig. 8.7, the states and EPS value for the states is described in Table 8.14 below.

Table 8.14: Enabled Parent State values for example system

Category / Bit Value	State	Enabled Parent State
System Level ProcessorContainer LPI States		
0	Running	N/A
1	Power Down	0
Cluster Level ProcessorContainer LPI States		
0	Running	N/A
1	Clock Gating	0 – System must be running if cluster is clock gated
2	Retention	0 – System must be running if cluster is in retention
3	Power Down	1 – System may be in power down if cluster is in power down
Core Level ProcessorContainer LPI States		
0	Running	N/A
1	Clock Gating	1 – Cluster may be clock gated or running of core is clock gated
2	Retention	2 – Cluster may running, or clock gated, or in retention if core is in retention
3	Power Down	3 – All states at cluster level are supported if the core is powered down

8.4.3.3.3 Power, Minimum Residency, and Worst Case Wakeup Latency

Power is not included in `_LPI` since relative power of different states (along with minimum residency to comprehend transition energy), and not absolute power, drive OSPM idle state decisions. To correctly convey relative power, local states in `_LPI` must be declared in power consumption order. That is, the local states for a particular hierarchy node must be listed from highest power (shallowest) to lowest power (deepest).

The worst case wakeup latency (WCWL) for a particular local state is the longest time from when a wake interrupt is asserted, to when the hierarchy node can return to execution. Generally, the WCWL will be the idle state's exit latency plus some portion of its entry latency. How much of the entry flow is included depends on where (and if) the platform supports checking for pending wake events and aborting the idle state entry. For any given power state there will be a "point of no return" after which the entry into the power state cannot be reversed. This is illustrated in *Worst case wakeup latency* below. The WCWL must include the time period from the point of no return to the time at which a wake up interrupt can be handled.

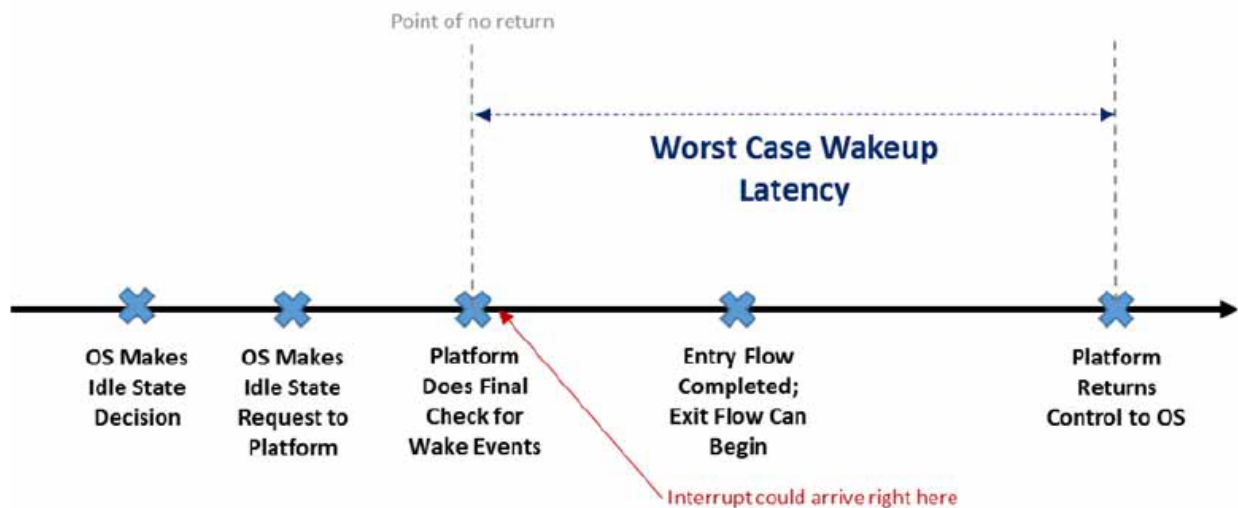

Fig. 8.8: Worst case wakeup latency

Note that other worst case paths could end up determining the WCWL, but what is described above is expected to be the most common. For example, there could be another period between the OS making the idle request and the point of no return where the platform does not check for wake up events, and which is longer than the time taken to enter and exit the power state. In that case that period would become the worst case wakeup latency.

Minimum residency (MR) is the time after which a state becomes more energy efficient than any shallower state. This parameter answers the fundamental question: how long does the hierarchy node need to stay in the idle state to overcome the energy cost of transitioning in/out, and make choosing that state a net win relative to shallower alternatives? Note that this also includes comparing against not entering an idle state and keeping the node running. This is illustrated in *Energy of states A, B and C versus sleep duration*, which shows the energy associated with three different state choices as a function of the sleep duration. Note that State A's MR relative to keeping the node running is not pictured.

Generally, minimum residency and worst case wakeup latency will be larger for deeper states, however this may not always be the case. Taking a different example to the above, consider two system level states, StateY and StateZ, with similar entry overhead but where StateZ saves more power than StateY. An abstract state list might look like:

```
StateX: MR = 100 us
StateY: MR = 1000 us
StateZ: MR = 800 us, power resource A must be OFF
```

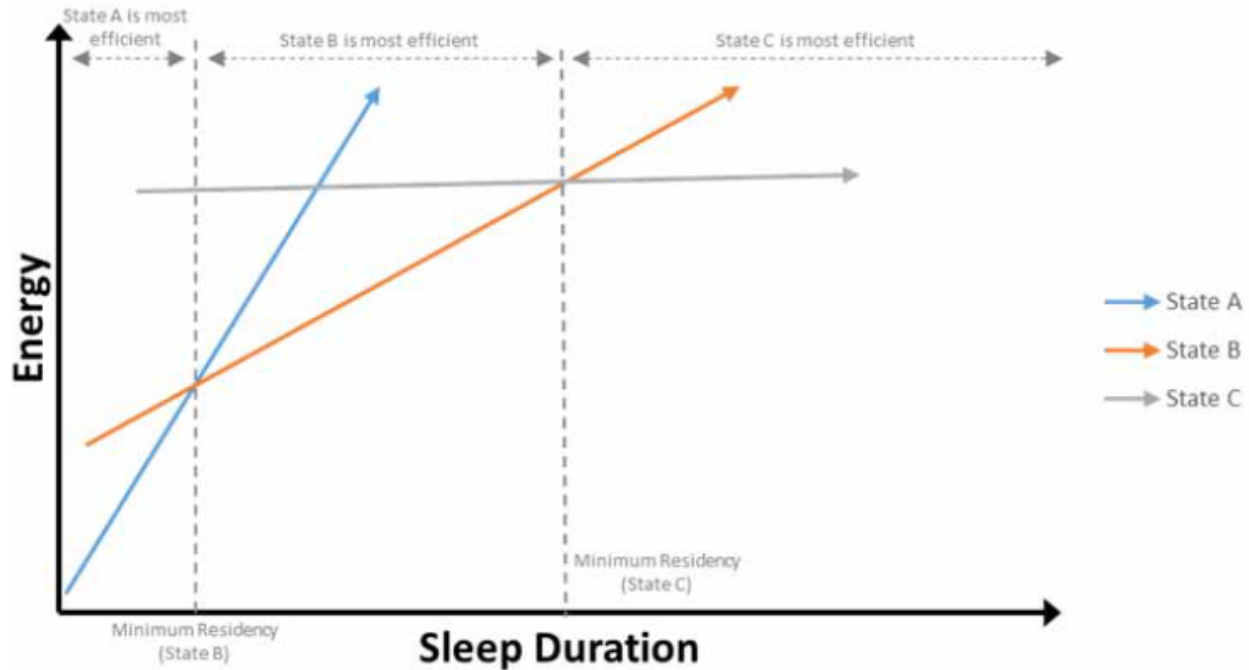

Fig. 8.9: Energy of states A,B and C versus sleep duration

From an energy perspective, StateZ is always preferred, but in this example, StateZ is only available when certain device dependencies are met. This makes StateY attractive when the dependencies cannot be met. Despite being the deeper (lower power) state, StateZ has a lower MR than StateY since the entry overheads are similar and StateZ's lower power more quickly amortizes the transition cost. Although the crossover, which sets MR, should generally be versus the next shallowest state, MR is defined relative to any shallower (higher power) state to deal with cases like this. In this case, StateZ's MR is set by the crossover with StateX since StateZ (if allowed based on device dependencies) is always preferred to StateY. To achieve the lowest energy, OSPM must select the deepest (lowest power) state for which all entry constraints are satisfied and should not assume that deeper states are not viable just because a shallower state's WCWL/MR threshold was not met.

Since WCWL may be used by OSPM to restrict idle state selection and guarantee response times to critical interrupts, it should be set conservatively (erring on the high side) so that OSPM is not surprised with worse than specified interrupt response time. On the other hand, MR helps OSPM make efficient decisions. If MR is inaccurate in a certain scenario and OSPM chooses a state which is deeper or shallower than optimal for a particular idle period, there may be some wasted energy but the system will not be functionally broken. This is not to say that MR doesn't matter -energy efficiency is important - just that the platform may choose to optimize MR based on the typical case rather than the worst case.

8.4.3.3.3.1 Minimum Residency and Worst Case Wakeup Latency Combination Across Hierarchy Levels

The WCWL in `_LPI` is for a particular local state. When evaluating composite state choices versus system latency tolerance as part of idle state selection, OSPM will add wakeup latencies across hierarchy levels. For example, if a system has core powerdown with WCWL = 50 us and cluster powerdown with WCWL = 20 us then the core powerdown + cluster powerdown composite state latency is calculated as 70 us.

MRs defined in `_LPI` apply to a particular hierarchy node. The implicit assumption is that each hierarchy node represents an independent power manageable domain and can be considered separately. For example, assume that a cluster retention state is legal if the underlying cores are in core powerdown or core retention. The MR for cluster

retention is based on the energy cost of taking shared logic outside of the cores in and out of retention versus the steady state power savings achieved in that shared logic while in that state. The key is that the specific state chosen at the core level does not fundamentally affect the cluster level decision since it is tied to properties of shared logic outside the core. The energy cost of entering/exiting the cluster state and the power savings it provides are independent of whether the core is in retention or powerdown. Based on this, MRs are considered independent per level in ACPI. That is, when comparing MR for different states to expected sleep duration for a particular node, OSPM uses the MRs defined in that node's `_LPI` as is with no adjustment based on states at lower levels of hierarchy (though of course the state must be legal based on the lower level state's Enabled Parent State property).

8.4.3.3.2 Known Limitations with Minimum Residency and Worst Case Wakeup Latency

Note that the WCWL and MR parameters are not perfect. For example, they do not scale with frequency, voltage, temperature, and various other factors which may affect them. Nor are the rules for how they combine across levels perfect. For example, cluster level MRs may move slightly based on core state choice since the entry latency of the core state will delay entry into the cluster state, derating the expected sleep duration. The cluster level MR can be adjusted to comprehend this, but if multiple core level states with different entry latencies enable the same cluster state, then its MR cannot perfectly comprehend them all. With that said, this set of parameters and combination scheme is believed to strike a good balance between simplicity/usability and accuracy.

8.4.3.3.4 Entry Method and Composition

The OSPM combines Local LPI states to create an overall composite power state. Each LPI state provides an entry method field. These fields, for the selected local power states, are combined to create the entry method register that must be read in order to enter a given composite power state.

To derive the appropriate register address from the local states' entry methods, the following approach is used:

1. Local states for Processors always declare a register based entry method. This provides a base register.
2. Higher levels may use an integer or a register. If an Integer is used, then its value must be added to the base register obtained in step 1. If a register is used, then this becomes the new base register, overriding any previous value. Note that in this case, the selected LPI must imply specific local LPI selections for all lower level nodes.
3. In OS Initiated mode it is also necessary for the OSPM to tell the platform on which hierarchy level the calling processor is the last to go idle. This is done by adding the Level ID property of the hierarchy node's LPI to the base register.

The basic composition algorithm for entry state is shown in the pseudo-code below for a platform coordinated system:

```

Reg = SelectedLocalState(CurrentProcessor).EntryMethod
WCWL = SelectedLocalState(CurrentProcessor).WCWL
MR = SelectedLocalState(CurrentProcessor).MR

for level = Parent(CurrentProcessor) to system
    LocalState = SelectedLocalState(level)
    If LocalState == Run
        break
    EM = LocalState.EntryMethod
    WCWL = WCWL + LocalState.WCWL
    MR = LocalState.MR
    If IsInteger(EM)
        Reg.Addr = Reg.Addr + ZeroExtend(EM)
    Else
        // Entry method here overrides any previous method
        Reg = EM

```

(continues on next page)

(continued from previous page)

```
CompositeState.EntryMethod = Reg
CompositeState.WCWL=WCWL
CompositeState.MR=MR
```

In OS Initiated mode it is also necessary for the OSPM to tell the platform on which hierarchy level the calling processor is the last to go idle and request a power state. To do this, the algorithm above is modified as follows:

```
Reg = SelectedLocalState(CurrentProcessor).EntryMethod
WCWL = SelectedLocalState(CurrentProcessor).WCWL
MR = SelectedLocalState(CurrentProcessor).MR

RegDecided = False
                // Retrieve Level Index from Processor's \_LPI object
LastLevel = GetLevelIDofLevel(CurrentProcessor)

for level = Parent(CurrentProcessor) to system
    LocalState = SelectedLocalState(level)

    If LocalState == Run
        break
    EM = LocalState.EntryMethod
    WCWL = WCWL+ LocalState.WCWL

    EM = LocalState.EntryMethod
    If IsInteger(EM)
        Reg.Addr = Reg.Addr+ZeroExtend(EM)
    Else
        // Entry method is register
        Reg = EM

If IsProcessorLastInLevel(CurrentProcessor,level)
    // If calling processor is last one to go idle in
    // current level, retrieve Level Index from
    // the container's \_LPI object
    LastLevel = GetLevelIDofLevel(level)

Reg.Addr = Reg.Addr+LastLevel
CompositeState.EntryMethod = Reg
CompositeState.WCWL=WCWL
CompositeState.MR=MR
```

In a platform coordinated system, it is possible for an LPI belonging to a hierarchy node above the processor level to use an integer value of zero as its entry method. Since entry method composition is done by addition, this results in the entry command for that state being the same as for a composite state which only includes its children. An entry value of 0 essentially identifies a state as “autopromotable.” This means that the OS does not explicitly request entry into this state, but that the platform can automatically enter it when all children have entered states which allow the parent state based on their EPS properties. OSPM should follow normal composition procedure for other parameters (worst case wakeup latency, minimum residency, etc.) when including composite states involving autopromotable local states.

This is described in the following example:

```
Device (SYSM) {
    // System level states
    Name (_HID, "ACPI0010")
    Name (_UID, 0)
    Name (_LPI,
        Package() {
```

(continues on next page)

(continued from previous page)

```

0,          // Version
0,          // Level ID
1,          // Count

Package () {          // Power gating state for system
    900,        // Min residency (uS)
    400,        // Wake latency (uS)
    0,          // Enabled Parent State
    ...        // (skipped fields) . . .
    ResourceTemplate () {
        Register (FFH, 0x20, 0x00, 0x00000000DECEA5ED, 0x3)
    },
    ...        // (skipped fields) . . .
}
)

Device (CLU0) {          // Package0 state
    Name (_HID, "ACPI0010")
    Name (_UID, 1)
    Name (_LPI,
        Package () {
            0,          // Version
            0,          // Level ID
            2,          // Count
            Package () {          // Retention state for Cluster
                40,        // Min residency (uS)
                20,        // Wake latency (uS)
                ...        // (skipped fields) . . .
                0,          // System must be running
                0,          // Integer Entry method
                ...        // (skipped fields) . . .
            },
            Package () {          // Power Gating state for Cluster
                100,       // Min residency (uS)
                80,        // Wake latency (uS)
                ...        // (skipped fields) . . .
                1,          // System may power down
                0x1020000, // Integer Entry method
                ...        // (skipped fields) . . .
            }
        }
    )
    Name (PLPI,
        Package () {
            0,          // Version
            0,          // Level ID
            2,          // Count
            Package () {          // Retention state for CPU
                40,        // Min residency (uS)
                20,        // Wake latency (uS)
                ...        // (skipped fields) . . .
                1,          // Parent node can be
                // in retention or running
            ResourceTemplate () {
                Register (FFH,

```

(continues on next page)

(continued from previous page)

```

        0x20,0x00,
        0x000000000000DEAF,0x3),
    }
    ...          // (skipped fields) . . .
},
Package () {   // Power Gating state for CPU
100,          // Min residency (uS)
80,          // Wake latency (uS)
...          // (skipped fields) . . .
2,          // Parent node can be in any state
ResourceTemplate () {
    // Register Entry method
    Register (FFH,
        0x20,0x00,
        0x000000000000DEAD,0x3),
    }
    ...          // (skipped fields) . . .
}
}
)
Device (CPU0) { // Core0
    Name (_HID, "ACPI0007")
    Method (_LPI, 0, NotSerialized)
    {
        return (PLPI)
    }
}
Device (CPU1) { // Core1
    Name (_HID, "ACPI0007")
    Method (_LPI, 0, NotSerialized)
    {
        return (PLPI)
    }
}
} // end of NOD0
Device (CLU1) { // Package1 state
    Name (_HID, "ACPI0010")
    Name (_UID, 2)
    ....
}
} // End of SYM

```

In the example above, the OSPM on CPU0 and CPU1 would be able to select the following composite states:

Table 8.15: Entry method example

Core LPI	Cluster LPI	System LPI	Composite State Entry Method
<i>Retention Register: 0xDEAF</i>	<i>Run</i>	<i>Run</i>	<i>Core Retention Register: 0xDEAF</i>
<i>Power Down Register 0xDEAD</i>	<i>Run</i>	<i>Run</i>	<i>Core Power Down Register: 0xDEAD</i>
<i>Retention Register: 0xDEAF</i>	<i>Retention Integer: 0x0</i>	<i>Run</i>	<i>Core Retain Retention Register 0xDEAF+0x0 = 0xDEAF</i>
<i>Power Down Register: 0xDEAD</i>	<i>Retention Integer: 0x0</i>	<i>Run</i>	<i>Core Power Down Retention Register 0xDEAD+0x102000 0 = 0xDEAD</i>

continues on next page

Table 8.15 – continued from previous page

Core LPI	Cluster LPI	System LPI	Composite State Entry Method
<i>Power Down Register: 0xDEAD</i>	<i>Power Down Integer: 0x1020000</i>	<i>Run</i>	<i>Core Power Down Power Down Register 0xDEAD+0x102000 0 = 0x102DEAD</i>
<i>Power Down Register: 0xDEAD</i>	<i>Power Down Integer: 0x1020000</i>	<i>Power Down Register : 0xDECEA5ED</i>	<i>System Power Down Register 0xDECEA5ED</i>

As can be seen in the example, the cluster level retention state defines the integer value of 0 as its entry method. By virtue of composition, this means that the entry methods for the composite states Core Power Down and Core Power Down|Cluster Retention are the same (FFH register 0xDEAD). Similarly the composite states for Core Retention and Core Retention|Cluster Retention are the same (FFH register 0xDEAF). Consequently, if both CPU0 and CPU1 are in either Power Down or Power Retention, then the platform may enter cluster CLU0 into Retention.

The example also shows how a register based entry method at a high level overrides entry method definitions of lower levels. As pointed above this is only possible if the selected LPI implies specific LPIs at all lower levels. In this example the System Power Down LPI, entered through FFH register 0xDECEA5ED, implies Power Down LPIs at core and cluster level since based on EPS, no other core/cluster local states could enable System Power Down.

8.4.3.3.5 Architecture Specific Context Loss Flags

For Intel based systems the value of this flags register is 0.

For ARM based systems please refer to links to ACPI-Related Documents (<http://uefi.org/acpi>) under the heading “ARM FFH Specification”.

8.4.3.3.6 Residency and Entry Counter Registers

LPI state descriptions may optionally provide Residency and Usage Count registers to allow the OSPM to gather statistics about the platform usage of a given local state. Both registers provide running counts of their respective statistics. To measure a statistic over some time window, OSPM should sample at the beginning and end and calculate the delta. Whether the counters restart from 0 on various flavors of reset/S-state exit is implementation defined so OSPM should resynchronize its baseline on any reset or Sx exit.

The registers are optional, and if the feature is not present the platform must use a NULL register of the following form:

```
ResourceTemplate() {Register {(SystemMemory, 0, 0, 0, 0)}}
```

The Usage Count register counts how many times the local state has been used. Whether it counts entries or exits is implementation defined.

The Residency register counts how long the hierarchy node has been in the given LPI state, at a rate given by LPI's Residency Counter Frequency field. A frequency of 0 indicates that the counter runs at an architecture-specific frequency. Whether the Residency counter runs continuously while in a local state or updates only on exit is implementation defined. If OSPM wants to guarantee that the reading for a particular state is current, it should read from that processor itself (or one of the underlying child processors in the case of a higher level idle state).

8.4.3.3.7 Wake from LPI States

With `_LPI`, the platform can describe deep S0-idle states which may turn off fundamental resources like bus clocks, interrupt controllers, etc. so special care must be taken to ensure that the platform can be woken from these states. This section describes handling for device initiated wakes. There are other wake sources such as timers, which are described elsewhere.

For device wakes, the requirement is that OSPM must not enter any LPI state that would prevent a device enabled for wake from waking the system. This means not entering any LPI state for which any Power Resource listed in `_RDI` (see the `_RDI` section *`_RDI (Resource Dependencies for Idle)`*) is required to be ON. Note that on a platform coordinated system, the OSPM may choose to enter an `_LPI` state even if there are resources listed in its companion RDI that are still on. However, if the OSPM has already enabled a device for wake, and ensured the power resources needed for wake are on, the platform will demote the LPI state to one where said resources remain on.

The wake device uses the standard `_PRx` and `_PRW` methods to describe power resources it requires to be ON based on its D-state and wake enabled status. This further implies that any device enabled for wake which depends on a resource which may be turned off as part of an LPI state must describe that dependency via `_PRx/_PRW => _RDI => _LPI`.

This is illustrated in the following example:

```
PowerResource(PWRA,0,0) {...}
PowerResource(PWRB,0,0) {...}
PowerResource(PWRC,0,0) {...}
PowerResource(PWRD,0,0) {...}
PowerResource(PWRE,0,1) {...}

Device (FOO) {
    Name(_S0W, 4) //Device in D3Cold can wake system from S0-idle
    Name(_PR0,Package(){PWRA, PWRB, PWRC})
    Name(_PR2,Package(){PWRA, PWRB})
    Name(_PR3,Package(){PWRA})
    Name(_PRE,Package(){PWRD})
    Name(_PRW,Package(){0, 0, PWRD}) // PWRD must be ON for FOO to wake system
}

Device (BAR) {
    Name(_S0W, 3) // Device in D3Hot can wake system from S0-idle
    Name(_PR0,Package(){PWRA, PWRB})
    Name(_PR3,Package(){PWRC})
    Name(_PRW,Package(){PWRC}) // PWRC must be ON for BAR to wake system
}

Device (BAH) {
    Name(_S0W, 0) // This device can only wake the system from
                // S0-idle if it is in D0
    Name(_PR0,Package(){PWRA, PWRB, PWRC})
}

Device (SYM) {
    Name(_RDI,
        Package() {
            0, // Version
            Package(){} // Local State 1 is Shallow;
                    // Devices FOO, BAR and BAH can wake
                    // the system if enabled for wake
            Package(){PWRA, PWRB} // RDI for Local State 2. State is deeper
                    // Device BAH cannot wake the system if this
                    // state is used, as it needs PWRA and PWRB
        }
    )
}
```

(continues on next page)

(continued from previous page)

```

Package() {PWRA, PWRB, PWRC} // to be able to wake the system
// RDI for Local State 3.
// Devices BAH and BAR cannot wake
// the system, BAH needs PWRA, PWRB
// and PWRC, and BAR needs PWRC
// for all devices
Package() {PWRA, PWRB, PWRC, PWRD} // None of the devices listed
// above could wake the system
})
...

```

The example above declares a set of power resources (PWRA/B/C/D). Additionally, it has four system level local states that have the following dependencies:

- LPI 1: Has no power resources dependencies
- LPI 2: Requires PWRA and PWRB to be off
- LPI 3: Requires PWRA, PWRB and PWRC to be off
- LPI 4: Requires all of the power resources in the example to be off

Device BAH can only wake the system if it is in the D0 state. To be in D0 it requires PWRA, PWRB and PWRC to be on. Therefore device BAH could only wake the system from LPI 1. If this device is enabled for wake, then the platform must not enter LPI 2 or deeper.

Device BAR can wake the system in whilst it is in any device state other than D3Cold. However, to do so, it requires PWRC to be on. Therefore it can only wake the system from LPI 1 or LPI 2. If this device is enabled for wake, then the platform must not enter LPI 3 or deeper.

Device FOO can wake the system whilst it is in any device state. However to do so, it requires PWRD to be on. Therefore it can only wake the system from LPI 1 or LPI 2 or LPI 3. If this device is enabled for wake, then the platform must not enter LPI 4.

8.4.3.3.8 Default Idle State

The shallowest idle state for each leaf node in the hierarchy is the “default” idle state for that processor and is assumed to always be enterable. The worst case wakeup latency and minimum residency for this state must be low enough that OSPM need not consider them when deciding whether to use it. Aside from putting the processor in a power state, this state has no other software-visible effects. For example, it does not lose any context that OSPM must save/restore or have any *device dependencies*.

8.4.3.4 _RDI (Resource Dependencies for Idle)

Some platforms may have power resources that are shared between devices and processors. Abstractly, these resources are managed in two stages. First, the OS does normal power resource reference counting to detect when all device dependencies have been satisfied and the resource may be power managed from the device perspective. Then, when the processors also go idle, the OS requests entry into specific LPI states and the platform physically power manages the resources as part of the transition. The dependency between the power resources and the LPI state is described in `_RDI`.

`_RDI` objects may only be present at the root processor container that describes the processor hierarchy of the system. `_RDI` is not supported in a system that has more than one root node. `_RDI` is valid only in a singular top level container which encompasses all processors in the system.

The OSPM will ignore `_RDI` objects that are present at any node other than the root node. This simplification avoids complicated races between processors in one part of the hierarchy choosing idle states with resource dependencies while another processor is changing device states/power resources.

Arguments:

None

Return Value:

A variable-length Package containing the resource dependencies with the following format:

Return Value Information

```
Package {
    Revision,    // Integer (WORD)
    RDI[1],     // Package
    ...
    RDI[N]      // Package
}
```

Table 8.16: `_RDI` package return values

Element	Object Type	Description
Revision	Integer (WORD)	The revision number of the <code>_RDI</code> object. Current revision is 0.
RDI[1]	Package	A variable length Package containing the power resource dependencies of system level power state 1.
RDI[N]	Package	A variable length Package containing the power resource dependencies of system level power state N.

Each `RDI[x]` sub-Package contains a variable number of References to power resources:

```
Package {
    Resource[0], // Object Reference to a Power Resource Object
    ...
    Resource[M] // Object Reference to a Power Resource Object
}
```

The **Package** contains as many RDI packages as there are system level power states in the root processor container node's `_LPI` object. The indexing of LPI power states in this `_LPI` object matches the indexing of the RDI packages in the `_RDI` object. Thus the *n*th LPI state at the system level has resource dependencies listed in the *n*th RDI. Each RDI package returns a list of the power resource objects (passive or standard power resources) that must be in an OFF state to allow the platform to enter the LPI state. If a system level LPI does not have any resource dependencies, the corresponding RDI should be an empty **Package**.

Both traditional and passive power resources can be listed as dependencies in `_RDI`. For traditional power resources, OSPM should ensure that the resource is OFF before requesting a dependent LPI state. For passive power resources, there are no `_ON/_OFF/_STA` methods so the only requirement is to check that the reference count is 0 before requesting a dependent LPI state.

OSPM requirements for ordering between device/power resource transitions and power resource dependent LPI states differ based on the coordination scheme.

In a platform coordinated system the platform must guarantee correctness and demote the requested power state to one that will satisfy the resource and processor dependencies. OSPM may use the dependency info in `_RDI` as it sees fit, and may select a dependent LPI state even if resources remain ON.

In an OS initiated system, OSPM must guarantee that all power resources are off (or reference counts are 0, for passive power resources) before requesting a dependent LPI state.

_RDI Example

The following ASL describes a system that uses `_RDI` to describe the dependencies between three power resources and system level power states:

```

PowerResource(PWRA,0,0) {           // power rail local to DEVA
    Method(_ON) {...}              // active power resource (_OFF turns rail off)
    Method(_OFF) {...}
    Method(_STA) {...}
}

PowerResource(PWRB,0,0) {           // power rail shared between DEVB and the processor
    Method(_ON) {...}              // active power resource (_OFF drives platform vote)
    Method(_OFF) {...}
    Method(_STA) {...}
}

PowerResource(PWRC,0,0) {}          // clock rail shared between DEVC and the processor
                                     // passive power resource

Device (DEVA) {
    Name(_PR0,Package() {PWRA})
}

Device (DEVB) {
    Name(_PR0,Package() {PWRB})
}

Device (DEVC) {
    Name(_PR0,Package() {PWRC})
}

Device (SYM) {
    Name(_RDI,
        Package() {
            0,                       // Revision
            Package() {}             // Local State 1 has no power resource
                                     // dependencies
            Package() {PWRA}         // Local State 2 cannot be entered if DEVA
                                     // is in D0 due to PWRA
            Package() {PWRA, PWRB, PWRC} // Local State 3 cannot be entered if
                                     // DEVA is in D0 (due to PWRA), DEVB is in
                                     // D0 (due to PWRB) or DEVC is in D0
                                     // (due to PWRC)
        })
    ...
}

```

OSPM will turn the traditional power resource (PWRA) ON or OFF by waiting for the reference count to reach 0 (meaning DEVA has left D0) and running the `_OFF` method. Similarly, PWRB is turned ON or OFF based on the state of DEVB. Note that because the CPUs require the shared power rail to be ON while they are running, PWRB's `_ON` and `_OFF` drive a vote rather than the physical HW controls for the power rail. In this case, `_STA` reflects the status of the vote rather than the physical state of PWRB.

OSPM guarantees ordering between PWRA/PWRB's `_ON` and `_OFF` transitions and DEVA/DEVB's D-state transitions. That is, PWRA can only be turned OFF after DEVA has left D0, and must be turned ON before transitioning DEVA to D0. However, the OS requirements for ordering between power resource transitions and power resource dependent LPI states differ based on the coordination scheme.

In a platform coordinated system, OSPM may or may not track the power state of PWRA before selecting local state 2 or 3. The platform must independently guarantee that PWRA is OFF before entering local state 2 or 3, and must

demote to a shallower state if OSPM selects local state 2 or 3 when PWRA is still on. Note that because OSPM is required to correctly sequence power resource transitions with device power transitions, the platform does not need to check the state of DEVA; it can rely on the state of PWRA to infer that DEVA is in an appropriate D-state.

Similarly, OSPM may or may not track the state of PWRB and PWRC before selecting local state 3, and the platform must independently guarantee that PWRB is off before entering either state. Because PWRC is a passive power resource, the platform does not know when the reference count on the power resource reaches 0 and instead must track DEVC's state itself. Unless the platform has other mechanisms to track the state of DEVC, PWRC should be defined as a traditional power resource so that the platform can use its `_ON` and `_OFF` methods to guarantee correctness of operation.

In an OS initiated system, OSPM is required to guarantee that PWRA is OFF before selecting either local state 2 or 3. OSPM may meet this guarantee by waiting until it believes a processor is the last man down in the system, before checking the state of PWRA, and only selecting local state 2 or 3 in this case. If the processor was the last man down, then the request to enter local state 2 or 3 is legal and the platform can honor it. If another processor woke up in the meantime and turned PWRA on, then this becomes a race between processors which is addressed in the OS Initiated Request Semantics section (*OS Initiated Request Semantics*). Similarly, OSPM must guarantee PWRB is off and PWRC's reference count is 0 before selecting local state 3.

In an OS initiated system, because OSPM guarantees that power resources are in their correct states before selecting system power states, the platform should use passive power resources unless there is additional runtime power savings to turning a power resource OFF. On a platform that only supports OS Initiated transitions, PWRB should be defined as a passive power resource because it is shared with processors and can only be turned off when the system power state is entered.

8.4.3.5 Compatibility

In order to support older operating systems which do not support the new idle management infrastructure, the `_OSC` method can be used to detect whether the OSPM supports parsing processor containers and objects associated with LPIs and (`_LPI`, `_RDI`). This is described in *Rules for Evaluating _OSC*.

A platform may choose to expose both `_CST` and `_LPI` for backward compatibility with operating systems which do not support `_LPI`. In this case, if OSPM supports `_LPI`, then it should be used in preference to `_CST`. At run time only one idle state methodology should be used across the entire processor hierarchy - `_LPI` or `_CST`, but not a mixture of both.

8.4.4 Processor Throttling Controls

ACPI defines two processor throttling (T state) control interfaces. These are:

- The Processor Register Block's (P_BLK's) P_CNT register.
- The combined `_PTC`, `_TSS`, and `_TPC` objects in the processor's object list.

P_BLK based throttling state controls are described in *ACPI Hardware Specification*. Combined `_PTC`, `_TSS`, and `_TPC` based throttling state controls expand the functionality of the P_BLK based control allowing the number of T states to be dynamic and accommodate CPU architecture specific T state control mechanisms as indicated by registers defined using the Functional Fixed Hardware address space. While platform definition of the `_PTC`, `_TSS`, and `_TPC` objects is optional, all three objects must exist under a processor for OSPM to successfully perform processor throttling via these controls.

8.4.4.1 _PTC (Processor Throttling Control)

_PTC is an optional object that defines a processor throttling control interface alternative to the I/O address spaced-based P_BLK throttling control register (P_CNT) described in *ACPI Hardware Specification*

OSPM performs processor throttling control by writing the Control field value for the target throttling state (T-state), retrieved from the Throttling Supported States object (_TSS), to the Throttling Control Register (THROTTLE_CTRL) defined by the _PTC object. OSPM may select any processor throttling state indicated as available by the value returned by the _TPC control method.

Success or failure of the processor throttling state transition is determined by reading the Throttling Status Register (THROTTLE_STATUS) to determine the processor’s current throttling state. If the transition was successful, the value read from THROTTLE_STATUS will match the “Status” field in the _TSS entry that corresponds to the targeted processor throttling state.

Arguments:

None

Return Value:

A Package as described below

Return Value Information

```
Package
{
    ControlRegister    // Buffer (Resource Descriptor)
    StatusRegister    // Buffer (Resource Descriptor)
}
```

Table 8.17: _PTC Package Values

Element	Object Type	Description
Control Register	Buffer	Contains a Resource Descriptor with a single Register() descriptor that describes the throttling control register.
Status Register	Buffer	Contains a Resource Descriptor with a single Register() descriptor that describes the throttling status register.

The platform must expose a _PTC object for either all or none of its processors. Notice that if the _PTC object exists, the specified register is used instead of the P_CNT register specified in the Processor term. Also notice that if the _PTC object exists and the _CST object does not exist, OSPM will use the processor control register from the _PTC object and the P_LVLx registers from the P_BLK.

Example

This is an example usage of the _PTC object in a Processor object list:

```
Processor (
    \_SB.CPU0,           // Processor Name
    1,                   // ACPI Processor number
    0x120,               // PBlk system IO address
    6 )                 // PBlkLen
{
    Name(_PTC, Package () // Processor Throttling Control object
    {
        ResourceTemplate() {Register(FFixedHW, 0, 0, 0)}, // Throttling_CTRL
        ResourceTemplate() {Register(FFixedHW, 0, 0, 0)} // Throttling_STATUS
    })
    // End of \_PTC object
```

(continues on next page)

(continued from previous page)

```
} // End of Object List
```

Example

This is an example usage of the `_PTC` object using the values defined in ACPI 1.0. This is an illustrative example to demonstrate the mechanism with well-known values.

```
Processor (
    \_SB.CPU0,           // Processor Name
    1,                  // ACPI Processor number
    0x120,              // PBLK system IO address
    6 )                // PBLK Len
{
    // Object List
    Name(_PTC, Package () // Processor Throttling Control object -
        // 32 bit wide IO space-based register at the <p_blk> address
    {
        ResourceTemplate() {Register(SystemIO, 32, 0, 0x120)}, // Throttling_CTRL
        ResourceTemplate() {Register(SystemIO, 32, 0, 0x120)} // Throttling_STATUS
    }) // End of \_PTC object
} // End of Object List
```

8.4.4.2 _TSS (Throttling Supported States)

This optional object indicates to OSPM the number of supported processor throttling states that a platform supports. This object evaluates to a packaged list of information about available throttling states including percentage of maximum internal CPU core frequency, maximum power dissipation, control register values needed to transition between throttling states, and status register values that allow OSPM to verify throttling state transition status after any OS-initiated transition change request. The list is sorted in descending order by power dissipation. As a result, the zeroth entry describes the highest performance throttling state (no throttling applied) and the 'nth' entry describes the lowest performance throttling state (maximum throttling applied).

When providing the `_TSS`, the platform must supply a `_TSS` entry whose Percent field value is 100. This provides a means for OSPM to disable throttling and achieve maximum performance.

Arguments:

None

Return Value:

A variable-length **Package** containing a list of Tstate sub-packages as described below.

Return Value Information

```
Package {
    TState [0] // Package - Throttling state 0
    ....
    TState [n] // Package - Throttling state n
}
```

Each Tstate **sub-Package** contains the elements described below.

```
Package {
    Percent // Integer (DWORD)
    Power // Integer (DWORD)
    Latency // Integer (DWORD)
    Control // Integer (DWORD)
```

(continues on next page)

(continued from previous page)

```

    Status      // Integer (DWORD)
}
    
```

Table 8.18: TState Package Values

Element	Object Type	Description
Percent	Integer (DWORD)	Indicates the percent of the core CPU operating frequency that will be available when this throttling state is invoked. The range for this field is 1-100. This percentage applies independent of the processor's performance state (P-state). That is, this throttling state will invoke the percentage of maximum frequency indicated by this field as applied to the CoreFrequency field of the _PSS entry corresponding to the P-state for which the processor is currently resident.
Power	Integer (DWORD)	Indicates the throttling state's maximum power dissipation (in milliWatts). OSPM ignores this field on platforms the support P-states, which provide power dissipation information via the _PSS object.
Latency	Integer (DWORD)	Indicates the worst-case latency in microseconds that the CPU is unavailable during a transition from any throttling state to this throttling state.
Control	Integer (DWORD)	Indicates the value to be written to the Processor Control Register (THROTTLE_CTRL) in order to initiate a transition to this throttling state.
Status	Integer (DWORD)	Indicates the value that OSPM will compare to a value read from the Throttle Status Register (THROTTLE_STATUS) to ensure that the transition to the throttling state was successful. OSPM may always place the CPU in the lowest power throttling state, but additional states are only available when indicated by the _TPC control method. A value of zero indicates the transition to the Throttling state is asynchronous, and as such no status value comparison is required.

8.4.4.3 _TPC (Throttling Present Capabilities)

This optional object is a method that dynamically indicates to OSPM the number of throttling states currently supported by the platform. This method returns a number that indicates the _TSS entry number of the highest power throttling state that OSPM can use at a given time. OSPM may choose the corresponding state entry in the _TSS as indicated by the value returned by the _TPC method or any lower power (higher numbered) state entry in the _TSS.

Arguments:

None

Return Value:

An **Integer** containing the number of states supported:

- 0 - states 0 ... nth state available (all states available)
- 1 - state 1 ... nth state available
- 2 - state 2 ... nth state available
- ...
- n* - state *n* available only

In order to support dynamic changes of _TPC object, Notify events on the processor object of type 0x82 will cause OSPM to reevaluate any _TPC object in the processor's object list. This allows AML code to notify OSPM when the number of supported throttling states may have changed as a result of an asynchronous event. OSPM ignores _TPC Notify events on platforms that support P-states unless the platform has limited OSPM's use of P-states to the lowest power P-state. OSPM may choose to disregard any platform conveyed T-state limits when the platform enables OSPM usage of other than the lowest power P-state.

8.4.4.4 _TSD (T-State Dependency)

This optional object provides T-state control cross logical processor dependency information to OSPM. The _TSD object evaluates to a packaged list containing a single entry that expresses the T-state control dependency among a set of logical processors.

Arguments:

None

Return Value:

A Package containing a single entry consisting of a T-state dependency Package as described below.

Return Value Information

```

Package {
    TStateDependency[0]    // Package
}

The TStateDependency sub-Package contains the elements described below:
Package {
    NumEntries            // Integer
    Revision              // Integer (BYTE)
    Domain                // Integer (DWORD)
    CoordType            // Integer (DWORD)
    NumProcessors        // Integer (DWORD)
}
    
```

Table 8.19: T-State Dependency Package Values

Element	Object Type	Description
NumEntries	Integer	The number of entries in the TStateDependency package including this field. Current value is 5.
Revision	Integer (BYTE)	The revision number of the TStateDependency package format. Current value is 0.
Domain	Integer (DWORD)	The dependency domain number to which this T state entry belongs.
CoordType	Integer (DWORD)	See Table 8.1 for supported T-state coordination types.
Num Processors	Integer (DWORD)	The number of processors belonging to the domain for this logical processor's T-states. OSPM will not start performing power state transitions to a particular T-state until this number of processors belonging to the same domain have been detected and started.

Example

This is an example usage of the _TSD structure in a Processor structure in the namespace. The example represents a two processor configuration with three T-states per processor. For all T-states, there exists dependence between the two processors, such that one processor transitioning to a particular T-state, causes the other processor to transition to the same T-state. OSPM will be required to coordinate the T-state transitions between the two processors and can initiate a transition on either processor to cause both to transition to the common target T-state.

```

Processor (
    \_SB.CPU0,           // Processor Name
    1,                  // ACPI Processor number
    0x120,              // PBlk system IO address
    6)                 // PBlkLen
    
```

(continues on next page)

(continued from previous page)

```

{
    //Object List

    Name(_PTC, Package () // Processor Throttling Control object -
    // 32 bit wide IO space-based register at the <p_blk> address
    {
        ResourceTemplate(){Register(SystemIO, 32, 0, 0x120)}, // Throttling_CTRL
        ResourceTemplate(){Register(SystemIO, 32, 0, 0x120)} // Throttling_STATUS
    }) // End of \_PTC object

    Name (_TSS, Package())
    {
        Package () {
            0x64, // Frequency Percentage (100%, Throttling OFF state)
            0x0, // Power
            0x0, // Transition Latency
            0x7, // Control THT_EN:0 THTL_DTY:111
            0x0, // Status
        }

        Package () {
            0x58, // Frequency Percentage (87.5%)
            0x0, // Power
            0x0, // Transition Latency
            0xF, // Control THT_EN:1 THTL_DTY:111
            0x0, // Status
        }

        Package () {
            0x4B, // Frequency Percentage (75%)
            0x0, // Power
            0x0, // Transition Latency
            0xE, // Control THT_EN:1 THTL_DTY:110
            0x0, // Status
        }
    })

    Name (_TSD, Package())
    {
        Package(){5, 0, 0, 0xFD, 2} // 5 entries, Revision 0, Domain 0,
        // OSPM Coordinate, 2 Procs
    }) // End of \_TSD object

    Method (_TPC, 0) // Throttling Present Capabilities method
    {
        If (\_SB.AC)
        {
            Return(0) // All Throttle States are available for use.
        }
        Else
        {
            Return(2) // Throttle States 0 an 1 won't be used.
        }
    } // End of \_TPC method
} // End of processor object list

Processor (
    \_SB.CPU1, // Processor Name

```

(continues on next page)

(continued from previous page)

```

2,                // ACPI Processor number
,                // PBlk system IO address
)                // PBlkLen
{ //Object List

Name(_PTC, Package () // Processor Throttling Control object -
                        // 32 bit wide IO space-based register at the
                        // <p_blk> address
{
ResourceTemplate(){Register(SystemIO, 32, 0, 0x120)}, // Throttling_CTRL
ResourceTemplate(){Register(SystemIO, 32, 0, 0x120)} // Throttling_STATUS
}) // End of \_PTC object

Name (_TSS, Package()
{
Package () {
0x64,          // Frequency Percentage (100%, Throttling OFF state)
0x0,          // Power
0x0,          // Transition Latency
0x7,          // Control THT_EN:0 THTL_DTY:111
0x0,          // Status
}

Package () {
0x58,          // Frequency Percentage (87.5%)
0x0,          // Power
0x0,          // Transition Latency
0xF,          // Control THT_EN:1 THTL_DTY:111
0x0,          // Status
}\'

Package () {
0x4B,          // Frequency Percentage (75%)
0x0,          // Power
0x0,          // Transition Latency
0xE,          // Control THT_EN:1 THTL_DTY:110
0x0,          // Status
}
})

Name (_TSD, Package()
{
Package(){5, 0, 0, 0xFD, 2} // 5 entries, Revision 0, Domain 0,
                          // OSPM Coordinate, 2 Procs
}) // End of \_TSD object

Method (_TPC, 0) // Throttling Present Capabilities method
{
If (\_SB.AC)
{
Return(0) // All Throttle States are available for use.
}
Else
{
Return(2) // Throttle States 0 an 1 won't be used.
}
}

```

(continues on next page)

(continued from previous page)

```

    }
} // End of \_TPC method
} // End of processor object list

```

8.4.4.5 _TDL (T-state Depth Limit)

This optional object evaluates to the _TSS entry number of the lowest power throttling state that OSPM may use. _TDL enables the platform to limit the amount of performance reduction that OSPM may invoke using processor throttling controls in an attempt to alleviate an adverse thermal condition. OSPM may choose the corresponding state entry in the _TSS as indicated by the value returned by the _TDL object or a higher performance (lower numbered) state entry in the _TSS down to and including the _TSS entry number returned by the _TPC object or the first entry in the table (if _TPC is not implemented). The value returned by the _TDL object must be greater than or equal to the value returned by the _TPC object or the corresponding value to the last entry in the _TSS if _TPC is not implemented. In the event of a conflict between the values returned by the evaluation of the _TDL and _TPC objects, OSPM gives precedence to the _TPC object, limiting power consumption.

Arguments:

None

Return Value:

An Integer containing the Throttling Depth Limit _TSS entry number:

- 0 - throttling disabled.
- 1 - state 1 is the lowest power T-state available.
- 2 - state 2 is the lowest power T-state available.
- ...
- n - state n is the lowest power T-state available.

In order for the platform to dynamically indicate the limit of performance reduction that is available for OSPM use, Notify events on the processor object of type 0x82 will cause OSPM to reevaluate any _TDL object in the processor's object list. This allows AML code to notify OSPM when the number of supported throttling states may have changed as a result of an asynchronous event. OSPM ignores _TDL Notify events on platforms that support P-states unless the platform has limited OSPM's use of P-states to the lowest power P-state. OSPM may choose to disregard any platform conveyed T-state depth limits when the platform enables OSPM usage of other than the lowest power P-state.

8.4.5 Processor Performance Control

Processor performance control is implemented through three optional objects whose presence indicates to OSPM that the platform and CPU are capable of supporting multiple performance states. The platform must supply all three objects if processor performance control is implemented. The platform must expose processor performance control objects for either all or none of its processors. The processor performance control objects define the supported processor performance states, allow the processor to be placed in a specific performance state, and report the number of performance states currently available on the system.

In a multiprocessing environment, all CPUs must support the same number of performance states and each processor performance state must have identical performance and power-consumption parameters. Performance objects must be present under each processor object in the system for OSPM to utilize this feature.

Processor performance control objects include the '_PCT' package, '_PSS' package, and the '_PPC' method as detailed below.

8.4.5.1 _PCT (Performance Control)

This optional object declares an interface that allows OSPM to transition the processor into a performance state. OSPM performs processor performance transitions by writing the performance state-specific control value to a Performance Control Register (PERF_CTRL).

OSPM may select a processor performance state as indicated by the performance state value returned by the _PPC method, or any lower power (higher numbered) state. The control value to write is contained in the corresponding _PSS entry’s “Control” field.

Success or failure of the processor performance transition is determined by reading a Performance Status Register (PERF_STATUS) to determine the processor’s current performance state. If the transition was successful, the value read from PERF_STATUS will match the “Status” field in the _PSS entry that corresponds to the desired processor performance state.

Arguments:

None

Return Value:

A Package as described below

Return Value Information

```
Package
{
    ControlRegister      // Buffer (Resource Descriptor)
    StatusRegister      // Buffer (Resource Descriptor)
}
```

Table 8.20: _PCT Package Values

Element	Object Type	Description
Control Register	Buffer	Contains a Resource Descriptor with a single Register() descriptor that describes the performance control register.
Status Register	Buffer	Contains a Resource Descriptor with a single Register() descriptor that describes the performance status register.

Example

```
Name (_PCT, Package()
{
    ResourceTemplate() {Perf_Ctrl_Register}, //Generic Register Descriptor
    ResourceTemplate() {Perf_Status_Register} //Generic Register Descriptor
}) // End of \_PCT
```

8.4.5.2 _PSS (Performance Supported States)

This optional object indicates to OSPM the number of supported processor performance states that any given system can support. This object evaluates to a packaged list of information about available performance states including internal CPU core frequency, typical power dissipation, control register values needed to transition between performance states, and status register values that allow OSPM to verify performance transition status after any OS-initiated transition change request. The list is sorted in descending order by typical power dissipation. As a result, the zeroth entry describes the highest performance state and the ‘nth’ entry describes the lowest performance state.

Arguments:

None

Return Value:

A variable-length Package containing a list of Pstate sub-packages as described below

Return Value Information

```
Package {
    PState [0]           // Package - Performance state 0
    ....
    PState [n]          // Package - Performance state n
}
```

Each Pstate sub-Package contains the elements described below:

```
Package {
    CoreFrequency       // Integer (DWORD)
    Power               // Integer (DWORD)
    Latency             // Integer (DWORD)
    BusMasterLatency   // Integer (DWORD)
    Control             // Integer (DWORD)
    Status              // Integer (DWORD)
}
```

Table 8.21: PState Package Values

Element	Object Type	Description
Core Frequency	Integer (DWORD)	Indicates the core CPU operating frequency (in MHz).
Power	Integer (DWORD)	Indicates the performance state’s maximum power dissipation (in milliwatts).
Latency	Integer (DWORD)	Indicates the worst-case latency in microseconds that the CPU is unavailable during a transition from any performance state to this performance state.
Bus Master Latency	Integer (DWORD)	Indicates the worst-case latency in microseconds that Bus Masters are prevented from accessing memory during a transition from any performance state to this performance state.
Control	Integer (DWORD)	Indicates the value to be written to the Performance Control Register (PERF_CTRL) in order to initiate a transition to the performance state.
Status	Integer (DWORD)	Indicates the value that OSPM will compare to a value read from the Performance Status Register (PERF_STATUS) to ensure that the transition to the performance state was successful. OSPM may always place the CPU in the lowest power state, but additional states are only available when indicated by the _PPC method.

8.4.5.3 _PPC (Performance Present Capabilities)

This optional object is a method that dynamically indicates to OSPM the number of performance states currently supported by the platform. This method returns a number that indicates the _PSS entry number of the highest performance state that OSPM can use at a given time. OSPM may choose the corresponding state entry in the _PSS as indicated by the value returned by the _PPC method or any lower power (higher numbered) state entry in the _PSS.

Arguments:

None

Return Value:

An Integer containing the range of states supported

0 - States 0 through nth state are available (all states available)

1 - States 1 through nth state are available

2 - States 2 through nth state are available

...

n - State *n* is available only

In order to support dynamic changes of _PPC object, Notify events on the processor object are allowed. Notify events of type 0x80 will cause OSPM to reevaluate any _PPC objects residing under the particular processor object notified. This allows AML code to notify OSPM when the number of supported states may have changed as a result of an asynchronous event (AC insertion/removal, docked, undocked, and so on).

8.4.5.3.1 OSPM _OST Evaluation

When processing of the _PPC object evaluation completes, OSPM evaluates the _OST object, if present under the Processor device, to convey _PPC evaluation status to the platform. _OST arguments specific to _PPC evaluation are described below.

Arguments: (2)

Arg0 - Source Event (Integer) : 0x80 Arg1 - Status Code (Integer) : see below

Return Value:

None

Argument Information:

Arg1 - Status Code 0: Success - OSPM is now using the performance states specified 1: Failure - OSPM has not changed the number of performance states in use.

8.4.5.4 Processor Performance Control Example

This is an example of processor performance control objects in a processor object list.

In this example, a uniprocessor platform that has processor performance capabilities with support for three performance states as follows:

1. 500 MHz (8.2W) supported at any time
2. 600 MHz (14.9W) supported only when AC powered
3. 650 MHz (21.5W) supported only when docked

It takes no more than 500 microseconds to transition from one performance state to any other performance state. During a performance transition, bus masters are unable to access memory for a maximum of 300 microseconds. The PERF_CTRL and PERF_STATUS registers are implemented as Functional Fixed Hardware.

The following ASL objects are implemented within the system:

_SB.DOCK: Evaluates to 1 if system is docked, zero otherwise.

_SB.AC: Evaluates to 1 if AC is connected, zero otherwise.

```

Processor (
  \_SB.CPU0,           // Processor Name
  1,                   // ACPI Processor number
  0x120,               // PBlk system IO address
  6 )                 // PBlkLen
{
  Name(_PCT, Package () // Performance Control object
  {
    ResourceTemplate() {Register(FFixedHW, 0, 0, 0)}, // PERF_CTRL
    ResourceTemplate() {Register(FFixedHW, 0, 0, 0)} // PERF_STATUS
  }) // End of _PCT object

  Name (_PSS, Package ()
  {
    Package() {650, 21500, 500, 300, 0x00, 0x08}, // Performance State zero (P0)
    Package() {600, 14900, 500, 300, 0x01, 0x05}, // Performance State one (P1)
    Package() {500, 8200, 500, 300, 0x02, 0x06} // Performance State two (P2)
  }) // End of _PSS object

  Method (_PPC, 0) // Performance Present Capabilities method
  {
    If (\_SB.DOCK)
    {
      Return(0) // All _PSS states available (650, 600, 500).
    }
    If (\_SB.AC)
    {
      Return(1) // States 1 and 2 available (600, 500).
    }
    Else
    {
      Return(2) // State 2 available (500)
    }
  } // End of _PPC method
} // End of processor object list

```

The platform will issue a Notify(_SB.CPU0, 0x80) to inform OSPM to re-evaluate this object when the number of available processor performance states changes.

8.4.5.5 _PSD (P-State Dependency)

This optional object provides performance control, P-state or CPPC, logical processor dependency information to OSPM. The _PSD object evaluates to a packaged list containing a single entry that expresses the performance control dependency among a set of logical processors.

Arguments:

None

Return Value:

A Package with a single entry consisting of a P-state dependency Package as described below.

Return Value Information

```
Package {
    PStateDependency[0]    // Package
}
```

The PStateDependency sub-Package contains the elements described below:

```
Package {
    NumEntries             // Integer
    Revision               // Integer (BYTE)
    Domain                 // Integer (DWORD)
    CoordType              // Integer (DWORD)
    NumProcessors         // Integer (DWORD)
}
```

Table 8.22: P-State Dependency Package Values

Element	Object Type	Description
NumEntries	Integer	The number of entries in the PStateDependency package including this field. Current value is 5.
Revision	Integer (BYTE)	The revision number of the PStateDependency package format. Current value is 0.
Domain	Integer (DWORD)	The dependency domain number to which this P state entry belongs.
CoordType	Integer (DWORD)	See Table 8.1 for supported P-state coordination types.
Num Processors	Integer (DWORD)	The number of processors belonging to the domain for this logical processor's P-states. OSPM will not start performing power state transitions to a particular P-state until this number of processors belonging to the same domain have been detected and started.

Example

This is an example usage of the _PSD structure in a Processor structure in the namespace. The example represents a two processor configuration with three performance states per processor. For all performance states, there exists dependence between the two processors, such that one processor transitioning to a particular performance state, causes the other processor to transition to the same performance state. OSPM will be required to coordinate the P-state transitions between the two processors and can initiate a transition on either processor to cause both to transition to the common target P-state.

```
Processor (
    \_SB.CPU0,           // Processor Name
```

(continues on next page)

(continued from previous page)

```

1,                // ACPI Processor number
0x120,           // PBlk system IO address
6 )             // PBlkLen
{
  Name(_PCT, Package () // Performance Control object
  {
    ResourceTemplate() {Register(FFixedHW, 0, 0, 0)}, // PERF_CTRL
    ResourceTemplate() {Register(FFixedHW, 0, 0, 0)} // PERF_STATUS
  }) // End of \_PCT object

  Name (_PSS, Package()
  {
    Package() {650, 21500, 500, 300, 0x00, 0x08}, // Performance State zero (P0)
    Package() {600, 14900, 500, 300, 0x01, 0x05}, // Performance State one (P1)
    Package() {500, 8200, 500, 300, 0x02, 0x06} // Performance State two (P2)
  }) // End of \_PSS object

  Method (_PPC, 0) // Performance Present Capabilities method
  {
  } // End of \_PPC method

  Name (_PSD, Package()
  {
    Package() {5, 0, 0, 0xFD, 2} // 5 entries, Revision 0, Domain 0, OSPM
    // Coordinate, Initiate on any Proc, 2 Procs
  }) // End of \_PSD object
} // End of processor object list

Processor (
  \_SB.CPU1, // Processor Name
  2, // ACPI Processor number
  , // PBlk system IO address
  ) // PBlkLen
{
  Name(_PCT, Package () // Performance Control object
  {
    ResourceTemplate() {Register(FFixedHW, 0, 0, 0)}, // PERF_CTRL
    ResourceTemplate() {Register(FFixedHW, 0, 0, 0)} // PERF_STATUS
  }) // End of \_PCT object

  Name (_PSS, Package()
  {
    Package() {650, 21500, 500, 300, 0x00, 0x08}, // Performance State zero (P0)
    Package() {600, 14900, 500, 300, 0x01, 0x05}, // Performance State one (P1)
    Package() {500, 8200, 500, 300, 0x02, 0x06} // Performance State two (P2)
  }) // End of \_PSS object

  Method (_PPC, 0) // Performance Present Capabilities method
  {
  } // End of \_PPC method

  Name (_PSD, Package()
  {
    Package() {5, 0, 0, 0xFD, 2} // 5 entries, Revision 0, Domain 0, OSPM
    // Coordinate, Initiate on any Proc, 2 Procs
  }) // End of \_PSD object
} // End of processor object list

```

8.4.5.6 _PDL (P-state Depth Limit)

This optional object evaluates to the _PSS entry number of the lowest performance P-state that OSPM may use when performing passive thermal control. OSPM may choose the corresponding state entry in the _PSS as indicated by the value returned by the _PDL object or a higher performance (lower numbered) state entry in the _PSS down to and including the _PSS entry number returned by the _PPC object or the first entry in the table (if _PPC is not implemented). The value returned by the _PDL object must be greater than or equal to the value returned by the _PPC object or the corresponding value to the last entry in the _PSS if _PPC is not implemented. In the event of a conflict between the values returned by the evaluation of the _PDL and _PPC objects, OSPM gives precedence to the _PPC object, limiting power consumption.

Arguments:

None

Return Value:

An Integer containing the P-state Depth Limit _PSS entry number:

0 - P0 is the only P-state available for OSPM use

1 - state 1 is the lowest power P-state available

2 - state 2 is the lowest power P-state available

...

n - state *n* is the lowest power P-state available

In order for the platform to dynamically indicate a change in the P-state depth limit, Notify events on the processor object of type 0x80 will cause OSPM to reevaluate any _PDL object in the processor's object list. This allows AML code to notify OSPM when the number of supported performance states may have changed as a result of an asynchronous event.

8.4.6 Collaborative Processor Performance Control

Collaborative processor performance control defines an abstracted and flexible mechanism for OSPM to collaborate with an entity in the platform to manage the performance of a logical processor. In this scheme, the platform entity is responsible for creating and maintaining a performance definition that backs a continuous, abstract, unit-less performance scale. During runtime, OSPM requests desired performance on this abstract scale and the platform entity is responsible for translating the OSPM performance requests into actual hardware performance states. The platform may also support the ability to autonomously select a performance level appropriate to the current workload. In this case, OSPM conveys information to the platform that guides the platform's performance level selection.

Prior processor performance controls (P-states and T-states) have described their effect on processor performance in terms of processor frequency. While processor frequency is a rough approximation of the speed at which the processor completes work, workload performance isn't guaranteed to scale with frequency. Therefore, rather than prescribe a specific metric for processor performance, Collaborative Processor Performance Control leaves the definition of the exact performance metric to the platform. The platform may choose to use a single metric such as processor frequency, or it may choose to blend multiple hardware metrics to create a synthetic measure of performance. In this way the platform is free to deliver the OSPM requested performance level without necessarily delivering a specific processor frequency. OSPM must make no assumption about the exact meaning of the performance values presented by the platform, or how they may correlate to specific hardware metrics like processor frequency.

Platforms must use the same performance scale for all processors in the system. On platforms with heterogeneous processors, the performance characteristics of all processors may not be identical. In this case, the platform must synthesize a performance scale that adjusts for differences in processors, such that any two processors running the same workload at the same performance level will complete in approximately the same time. The platform should expose

different capabilities for different classes of processors, so as to accurately reflect the performance characteristics of each processor.

The control mechanisms are abstracted by the `_CPC` object method, which describes how to control and monitor processor performance in a generic manner. The register methods may be implemented in the Platform Communications Channel (PCC) interface (see *Platform Communications Channel (PCC)*). This provides sufficient flexibility that the entity OSPM communicates with may be the processor itself, the platform chipset, or a separate entity (e.g., a BMC).

In order to provide backward compatibility with existing tools that report processor performance as frequencies, the `_CPC` object can optionally provide processor frequency range values for use by the OS. If these frequency values are provided, the restrictions on `_CPC` information usage still remain: the OSPM must make no assumption about the exact meaning of the performance values presented by the platform, and all functional decisions and interaction with the platform still happen using the abstract performance scale. The frequency values are only contained in the `_CPC` object to allow the OS to present performance data in a simple frequency range, when frequency is not discoverable from the platform via another mechanism.

8.4.6.1 `_CPC` (Continuous Performance Control)

This optional object declares an interface that allows OSPM to transition the processor into a performance state based on a continuous range of allowable values. OSPM writes the desired performance value to the Desired Performance Register, and the platform maps the desired performance to an internal performance state.. If supported by the platform, OSPM may alternatively enable autonomous performance level selection while specifying minimum and maximum performance requirements.

Optional `_CPC` package fields that are not supported by the platform should be encoded as follows:

- Integer fields: Integer 0
- Register fields: the following NULL register descriptor should be used:

```
ResourceTemplate() {Register {(SystemMemory, 0, 0, 0, 0)}}
```

Arguments:

None

Return Value:

A Package containing the performance control information.

The performance control package contains the elements described below:

```
Package
{
    NumEntries,                // Integer
    Revision,                  // Integer
    HighestPerformance,        // Integer or Buffer (Resource Descriptor)
    NominalPerformance,        // Integer or Buffer (Resource Descriptor)
    LowestNonlinearPerformance, // Integer or Buffer (Resource Descriptor)
    LowestPerformance,         // Integer or Buffer (Resource Descriptor)
    GuaranteedPerformanceRegister, // Buffer (Resource Descriptor)
    DesiredPerformanceRegister , // Buffer (Resource Descriptor)
    MinimumPerformanceRegister , // Buffer (Resource Descriptor)
    MaximumPerformanceRegister , // Buffer (Resource Descriptor)
    PerformanceReductionToleranceRegister, // Buffer (Resource Descriptor)
    TimeWindowRegister,        // Buffer (Resource Descriptor)
    CounterWraparoundTime,     // Integer or Buffer (Resource Descriptor)
    ReferencePerformanceCounterRegister, // Buffer (Resource Descriptor)
    DeliveredPerformanceCounterRegister, // Buffer (Resource Descriptor)
}
```

(continues on next page)

(continued from previous page)

```

PerformanceLimitedRegister, // Buffer (Resource Descriptor)
CPPCEnableRegister // Buffer (Resource Descriptor)
AutonomousSelectionEnable, // Integer or Buffer (Resource Descriptor)
AutonomousActivityWindowRegister, // Buffer (Resource Descriptor)
EnergyPerformancePreferenceRegister, // Buffer (Resource Descriptor)
ReferencePerformance // Integer or Buffer (Resource Descriptor)
LowestFrequency, // Integer or Buffer (Resource Descriptor)
NominalFrequency // Integer or Buffer (Resource Descriptor)
}
    
```

Table 8.23: Continuous Performance Control Package Values

Element	Object Type	Description
NumEntries	Integer	The number of entries in the _CPC package, including this one. Current value is 23.
Revision	Integer (BYTE)	The revision number of the _CPC package format. Current value is 3.
Highest Performance	Integer (DWORD) or Buffer	Indicates the highest level of performance the processor is theoretically capable of achieving, given ideal operating conditions. If this element is an Integer, OSPM reads the integer value directly. If this element is a Buffer, it must contain a Resource Descriptor with a single Register() to read the value from.
Nominal Performance	Integer (DWORD) or Buffer	Indicates the highest sustained performance level of the processor. If this element is an Integer, OSPM reads the integer value directly. If this element is a Buffer, it must contain a Resource Descriptor with a single Register() to read the value from.
Lowest Nonlinear Performance	Integer (DWORD) or Buffer	Indicates the lowest performance level of the processor with non-linear power savings. If this element is an Integer, OSPM reads the integer value directly. If this element is a Buffer, it must contain a Resource Descriptor with a single Register() to read the value from.
Lowest Performance	Integer (DWORD) or Buffer	Indicates the lowest performance level of the processor. If this element is an Integer, OSPM reads the integer value directly. If this element is a Buffer, it must contain a Resource Descriptor with a single Register() to read the value from.
Guaranteed Performance Register	Buffer	Optional. If supported, contains a resource descriptor with a single Register() descriptor that describes the register to read the current guaranteed performance from. See the section “Performance Limiting” for more details.
Desired Performance Register	Buffer	Contains a resource descriptor with a single Register() descriptor that describes the register to write the desired performance level. This register is optional when OSPM indicates support for CPPC2 in the platform-wide _OSC capabilities and the Autonomous Selection Enable register is Integer 1

continues on next page

Table 8.23 – continued from previous page

Element	Object Type	Description
Minimum Performance Register	Buffer	Optional. If supported, contains a resource descriptor with a single Register() descriptor that describes the register to write the minimum allowable performance level to. The value 0 is equivalent to Lowest Performance (no limit).
Maximum Performance Register	Buffer	Optional. If supported, contains a resource descriptor with a single Register() descriptor that describes the register to write the maximum allowable performance level to. All 1s is equivalent to Highest Performance (no limit).
Performance Reduction Tolerance Register	Buffer	Optional. If supported, contains a resource descriptor with a single Register() descriptor that describes the register to write the performance reduction tolerance.
Time Window Register	Buffer	Optional. If supported, contains a resource descriptor with a single Register() descriptor that describes the register to write the nominal length of time (in ms) between successive reads of the platform’s delivered performance register. See the section “Time Window Register” for more details.
Counter Wraparound Time	Integer (DWORD) or Buffer	Optional. If supported, indicates the minimum time to counter wraparound, in seconds. If this element is an Integer, OSPM reads the integer value directly. If this element is a Buffer (and supported), it must contain a Resource Descriptor with a single Register() to read the value from.
Reference Performance Counter Register	Buffer	Contains a resource descriptor with a single Register() descriptor that describes the register to read a counter that accumulates at a rate proportional the reference performance of the processor.
Delivered Performance Counter Register	Buffer	Contains a resource descriptor with a single Register() descriptor that describes the register to read a counter that accumulates at a rate proportional to the delivered performance of the processor.
Performance Limited Register	Buffer	Contains a resource descriptor with a single Register() descriptor that describes the register to read to determine if performance was limited. A nonzero value indicates performance was limited. This register is sticky, and will remain set until reset or OSPM clears it by writing 0. See the section “Performance Limiting” for more details.
CPPC EnableRegister	Buffer	Optional. If supported, contains a resource descriptor with a single Register() descriptor that describes a register to which OSPM writes a One to enable CPPC on this processor. Before this register is set, the processor will be controlled by legacy mechanisms (ACPI P-states, firmware, etc.).

continues on next page

Table 8.23 – continued from previous page

Element	Object Type	Description
Autonomous Selection Enable	Integer (DWORD) or Buffer	Optional. If supported, contains a resource descriptor with a single Register() descriptor that describes a register to which OSPM writes a One to enable autonomous performance level selection. Platforms that exclusively support Autonomous Selection must populate this field as an Integer with a value of 1.
AutonomousActivity-WindowRegister	Buffer	Optional. If supported, contains a resource descriptor with a single Register() descriptor that describes a register to which OSPM writes a time value that indicates a moving utilization sensitivity window for the autonomous selection policy.
EnergyPerformance-PreferenceRegister	Buffer	Optional. If supported, contains a resource descriptor with a single Register() descriptor that describes a register to which OSPM writes a value to control the Energy vs. Performance preference of the platform's energy efficiency and performance optimization policies when Autonomous Selection is enabled
Reference Performance	Integer (DWORD) or Buffer	Optional. If supported, indicates the performance level at which the Reference Performance Counter accumulates. If not supported, The Reference Performance Counter accumulates at the Nominal performance level. If this element is an Integer, OSPM reads the integer value directly. If this element is a Buffer (and supported), it must contain a Resource Descriptor with a single Register() to read the value from
Lowest Frequency	Integer (DWORD) or Buffer	Optional. If supported, indicates the lowest frequency for this processor in MHz. It should correspond roughly to the Lowest Performance value, but is not guaranteed to have any precise correlation. This value should only be used for the purpose of reporting processor performance in absolute frequency rather than on an abstract scale, and not for functional decisions or platform communication. If this element is an Integer, OSPM reads the integer value directly. If this element is a Buffer (and supported), it must contain a Resource Descriptor with a single Register() to read the value from.
Nominal Frequency	Integer (DWORD) or Buffer	Optional. If supported, indicates the nominal frequency for this processor in MHz. It should correspond roughly to the Nominal Performance value, but is not guaranteed to have any precise correlation. This value should only be used for the purpose of reporting processor performance in absolute frequency rather than on an abstract scale, and not for functional decisions or platform communication. If this element is an Integer, OSPM reads the integer value directly. If this element is a Buffer (and supported), it must contain a Resource Descriptor with a single Register() to read the value from.

The `_CPC` object provides OSPM with platform-specific performance capabilities / thresholds and control registers that OSPM uses to control the platform's processor performance settings. These are described in the following sections. While the platform may specify register sizes within an allowable range, the size of the capabilities / thresholds registers must be compatible with the size of the control registers. If the platform supports CPPC, the `_CPC` object

must exist under all processor objects. That is, OSPM is not expected to support mixed mode (CPPC & legacy PSS, _PCT, _PPC) operation.

Starting with ACPI Specification 6.2, all _CPC registers can be in PCC, System Memory, System IO, or Functional Fixed Hardware address spaces. OSPM support for this more flexible register space scheme is indicated by the “Flexible Address Space for CPPC Registers” _OSC bit.

8.4.6.1.1 Performance Capabilities / Thresholds

Performance-based controls operate on a continuous range of processor performance levels, not discrete processor states. As a result, platform capabilities and OSPM requests are specified in terms of performance thresholds. *Platform performance thresholds* outlines the static performance thresholds of the platform and the dynamic guaranteed performance threshold.

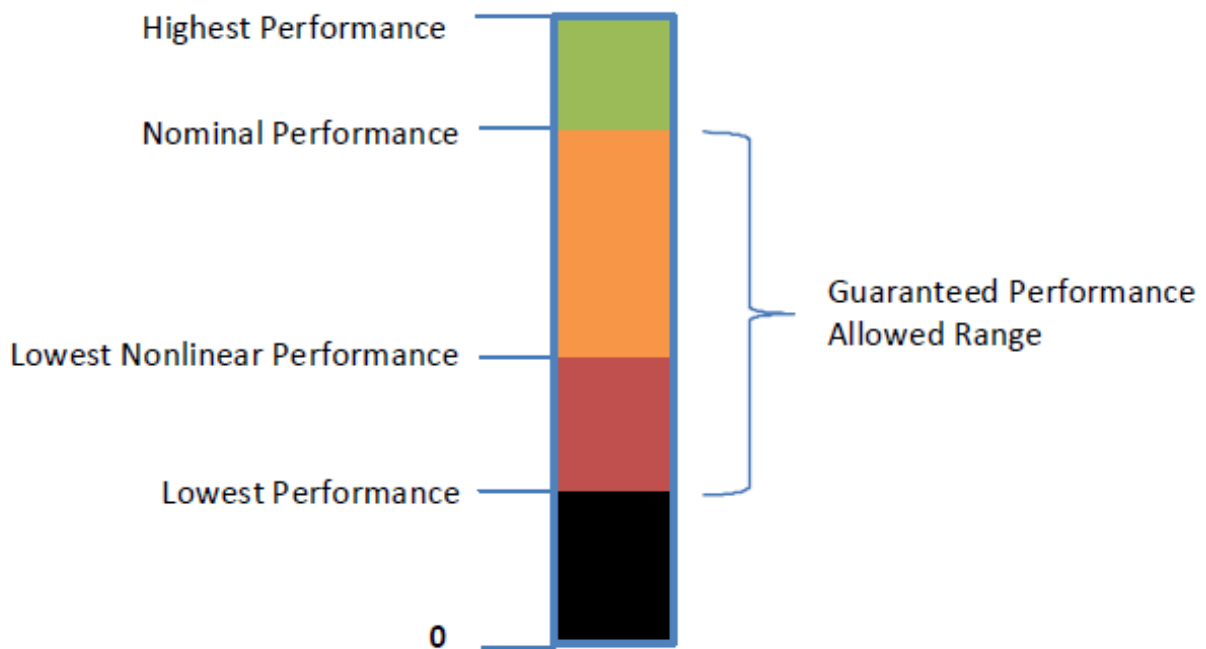

Fig. 8.10: Platform performance thresholds

Note: Not all performance levels need be unique. A platform’s nominal performance level may also be its highest performance level, for example.*

8.4.6.1.1.1 Highest Performance

```
Register or DWORD Attribute: Read
Size: 8-32 bits
```

Highest performance is the absolute maximum performance an individual processor may reach, assuming ideal conditions. This performance level may not be sustainable for long durations, and may only be achievable if other platform components are in a specific state; for example, it may require other processors be in an idle state.

Notify events of type 0x85 to the processor device object cause OSPM to re-evaluate the Highest Performance Register, but only when it is encoded as a buffer. Note: OSPM will not re-evaluate the `_CPC` object as a result of the notification.

8.4.6.1.1.2 Nominal Performance

Register	<code>or</code>	DWORD	Attribute:	Read
Size:				8-32 bits

Nominal Performance is the maximum sustained performance level of the processor, assuming ideal operating conditions. In absence of an external constraint (power, thermal, etc.) this is the performance level the platform is expected to be able to maintain continuously. All processors are expected to be able to sustain their nominal performance state simultaneously.

8.4.6.1.1.3 Reference Performance

Optional Register	<code>or</code>	DWORD	Attribute:	Read
Size:				8-32 bits

If supported by the platform, Reference Performance is the rate at which the Reference Performance Counter increments. If not implemented (or zero), the Reference Performance Counter increments at a rate corresponding to the Nominal Performance level.

8.4.6.1.1.4 Lowest Nonlinear Performance

Register	<code>or</code>	DWORD	Attribute:	Read
Size:				8-32 bits

Lowest Nonlinear Performance is the lowest performance level at which nonlinear power savings are achieved, for example, due to the combined effects of voltage and frequency scaling. Above this threshold, lower performance levels should be generally more energy efficient than higher performance levels. In traditional terms, this represents the P-state range of performance levels.

This register effectively conveys the most efficient performance level to OSPM.

8.4.6.1.1.5 Lowest Performance

Register	<code>or</code>	DWORD	Attribute:	Read
Size:				8-32 bits

Lowest Performance is the absolute lowest performance level of the platform. Selecting a performance level lower than the lowest nonlinear performance level may actually cause an efficiency penalty, but should reduce the instantaneous power consumption of the processor. In traditional terms, this represents the T-state range of performance levels.

8.4.6.1.1.6 Guaranteed Performance Register

Optional Attribute:	Read
Size:	8–32 bits

Guaranteed Performance Register conveys to OSPM a Guaranteed Performance level, which is the current maximum sustained performance level of a processor, taking into account all known external constraints (power budgeting, thermal constraints, AC vs DC power source, etc.). All processors are expected to be able to sustain their guaranteed performance levels simultaneously. The guaranteed performance level is required to fall in the range [Lowest Performance, Nominal performance], inclusive.

If this register is not implemented, OSPM assumes guaranteed performance is always equal to nominal performance.

Notify events of type 0x83 to the processor device object will cause OSPM to re-evaluate the Guaranteed Performance Register. Changes to guaranteed performance should not be more frequent than once per second. If the platform is not able to guarantee a given performance level for a sustained period of time (greater than one second), it should guarantee a lower performance level and opportunistically enter the higher performance level as requested by OSPM and allowed by current operating conditions.

8.4.6.1.1.7 Lowest Frequency and Nominal Frequency

Optional Register or DWORD Attribute:	Read
Size:	32 bits

If supported by the platform, Lowest Frequency and Nominal Frequency values convey are the lowest and nominal CPU frequencies of the platform, respectively, in megahertz (MHz). They should correspond roughly to Lowest Performance and Nominal Performance on the CPPC abstract performance scale but precise correlation is not guaranteed. See *Lowest Performance* and *Nominal Performance* for more details.

These values should not be used for functional decision making or platform communication which are based on the CPPC abstract performance scale. They are only intended to enable CPPC platforms to be backwards compatible with OSs that report performance as CPU frequencies. The OS should use Lowest Frequency/Performance and Nominal Frequency/Performance as anchor points to create a linear mapping of CPPC abstract performance to CPU frequency, interpolating between Lowest and Nominal, and extrapolating from Nominal to Highest. Note that this mapping is not guaranteed to be accurate since CPPC abstract performance is not required to be based purely on CPU frequency, but it is better than no data if the OS must report performance as CPU frequency. Platforms should provide these values when they must work with OSs which need to report CPU frequency, and there is no alternate mechanism to discover this information.

8.4.6.1.2 Performance Controls

Under CPPC, OSPM has several performance settings it may use in conjunction to control/influence the performance of the platform. These control inputs are outlined in the following figure.

OSPM may select any performance value within the continuous range of values supported by the platform. Internally, the platform may implement a small number of discrete performance states and may not be capable of operating at the exact performance level desired by OSPM. If a platform-internal state does not exist that matches OSPM's desired performance level, the platform should round desired performance as follows:

- If OSPM has selected a desired performance level greater than or equal to guaranteed performance, the platform may round up or down. The result of rounding must not be less than guaranteed performance.
- If OSPM has selected a desired performance level less than guaranteed performance and a maximum performance level not less than guaranteed performance, the platform must round up.

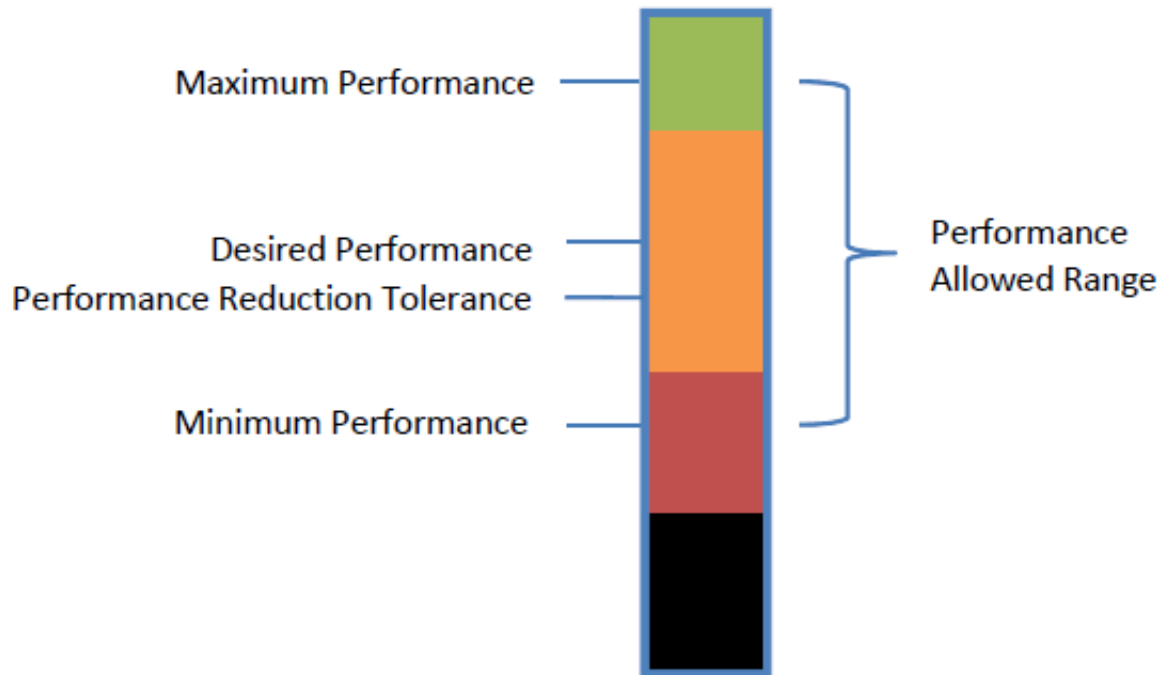

Fig. 8.11: OSPM performance controls

If OSPM has selected both desired performance level and maximum performance level less than guaranteed performance, the platform must round up if rounding up does not violate the maximum performance level. Otherwise, round down. OSPM must tolerate the platform rounding down if it chooses to set the maximum performance level less than guaranteed performance. This approach favors performance, except in the case where performance has been limited due to a platform or OSPM constraint.

When Autonomous Selection is enabled, OSPM limits the processor's performance selection by writing appropriate constraining values to the Minimum and Maximum Performance registers. Setting Minimum and Maximum to the same value effectively disables Autonomous selection.

Note: When processors are within the same dependency domain, Maximum performance may only be actually limited when allowed by hardware coordination.

8.4.6.1.2.1 Maximum Performance Register

Optional Attribute:	Read/Write
Size:	8-32 bits

Maximum Performance Register conveys the maximum performance level at which the platform may run. Maximum performance may be set to any performance value in the range [Lowest Performance, Highest Performance], inclusive.

The value written to the Maximum Performance Register conveys a request to limit maximum performance for the purpose of energy efficiency or thermal control and the platform limits its performance accordingly as possible. However, the platform may exceed the requested limit in the event it is necessitated by internal package optimization. For Example, hardware coordination among multiple logical processors with interdependencies.

OSPM's use of this register to limit performance for the purpose of thermal control must comprehend multiple logical processors with interdependencies. i.e. the same value must be written to all processors within a domain to achieve the desired result.

The platform must implement either both the Minimum Performance and Maximum Performance registers or neither register. If neither register is implemented and Autonomous Selection is disabled, the platform must always deliver the desired performance.

8.4.6.1.2.2 Minimum Performance Register

Optional Attribute:	Read/Write
Size:	8-32 bits

The Minimum Performance Register allows OSPM to convey the minimum performance level at which the platform may run. Minimum performance may be set to any performance value in the range [Lowest Performance, Highest Performance], inclusive but must be set to a value that is less than or equal to that specified by the Maximum Performance Register.

In the presence of a physical constraint, for example a thermal excursion, the platform may not be able to successfully maintain minimum performance in accordance with that set via the Minimum Performance Register. In this case, the platform issues a Notify event of type 0x84 to the processor device object and sets the Minimum_Excursion bit within the Performance Limited Register.

The platform must implement either both the Minimum Performance and Maximum Performance registers or neither register. If neither register is implemented and Autonomous Selection is disabled, the platform must always deliver the desired performance.

8.4.6.1.2.3 Desired Performance Register

Optional Attribute (depending on Autonomous Selection support):	Read/Write
Size:	8-32 bits

When Autonomous Selection is disabled, the Desired Performance Register is required and conveys the performance level OSPM is requesting from the platform. Desired performance may be set to any performance value in the range [Minimum Performance, Maximum Performance], inclusive. Desired performance may take one of two meanings, depending on whether the desired performance is above or below the guaranteed performance level.

- Below the guaranteed performance level, desired performance expresses the average performance level the platform must provide subject to the Performance Reduction Tolerance.
- Above the guaranteed performance level, the platform must provide the guaranteed performance level. The platform should attempt to provide up to the desired performance level, if current operating conditions allow for it, but it is not required to do so

When Autonomous Selection is enabled, it is not necessary for OSPM to assess processor workload performance demand and convey a corresponding performance delivery request to the platform via the Desired Register. If the Desired Performance Register exists, OSPM may provide an explicit performance requirement hint to the platform by writing a non-zero value. In this case, the delivered performance is not bounded by the Performance Reduction Tolerance Register, however, OSPM can influence the delivered performance by writing appropriate values to the Energy Performance Preference Register. Writing a zero value to the Desired Performance Register or the non-existence of the Desired Performance Register causes the platform to autonomously select a performance level appropriate to the current workload.

Note: The Desired Performance Register is optional only when OSPM indicates support for CPPC2 in the platform-wide _OSC capabilities and the Autonomous Selection Enable field is encoded as an Integer with a value of 1.*

8.4.6.1.2.4 Performance Reduction Tolerance Register

Optional Attribute:	Read/Write
Size:	8–32 bits

The Performance Reduction Tolerance Register is used by OSPM to convey the deviation below the Desired Performance that is tolerable. It is expressed by OSPM as an absolute value on the performance scale. Performance Tolerance must be less than or equal to the Desired Performance. If the platform supports the Time Window Register, the Performance Reduction Tolerance conveys the minimal performance value that may be delivered on average over the Time Window. If this register is not implemented, the platform must assume Performance Reduction Tolerance = Desired Performance.

When Autonomous Selection is enabled, values written to the Performance Reduction Tolerance Register are ignored.

8.4.6.1.2.5 Time Window Register

Optional Attribute:	Read/Write
Size:	8–32 bits
Units:	milliseconds

When Autonomous Selection is not enabled, OSPM may write a value to the Time Window Register to indicate a time window over which the platform must provide the desired performance level (subject to the Performance Reduction Tolerance). OSPM sets the time window when electing a new desired performance. The time window represents the minimum time duration for OSPM's evaluation of the platform's delivered performance (see *Performance Counters* "Performance Counters" for details on how OSPM computes delivered performance). If OSPM evaluates delivered performance over an interval smaller than the specified time window, it has no expectations of the performance delivered by the platform. For any evaluation interval equal to or greater than the time window, the platform must deliver the OSPM desired performance within the specified tolerance bound.

If OSPM specifies a time window of zero or if the platform does not support the time window register, the platform must deliver performance within the bounds of Performance Reduction Tolerance irrespective of the duration of the evaluation interval.

When Autonomous Selection is enabled, values written to the Time Window Register are ignored. Reads of the Time Window register indicate minimum length of time (in ms) between successive reads of the platform's performance counters. If the Time Window register is not supported then there is no minimum time requirement between successive reads of the platform's performance counters.

8.4.6.1.3 Performance Feedback

The platform provides performance feedback via set of performance counters, and a performance limited indicator.

8.4.6.1.3.1 Performance Counters

To determine the actual performance level delivered over time, OSPM may read a set of performance counters from the Reference Performance Counter Register and the Delivered Performance Counter Register.

OSPM calculates the delivered performance over a given time period by taking a beginning and ending snapshot of both the reference and delivered performance counters, and calculating:

The delivered performance should always fall in the range [Lowest Performance, Highest Performance], inclusive. OSPM may use the delivered performance counters as a feedback mechanism to refine the desired performance state it selects.

$$\text{delivered performance} = \text{reference performance} \times \frac{\Delta \text{delivered performance counter}}{\Delta \text{reference performance counter}}$$

When Autonomous Selection is not enabled, there are constraints that govern how and when the performance delivered by the platform may deviate from the OSPM Desired Performance. Corresponding to OSPM setting a Desired Performance: at any time after that, the following constraints on delivered performance apply

- Delivered performance can be higher than the OSPM requested desired performance if the platform is able to deliver the higher performance at same or lower energy than if it were delivering the desired performance.
- Delivered performance may be higher or lower than the OSPM desired performance if the platform has discrete performance states and needed to round down performance to the nearest supported performance level in accordance to the algorithm prescribed in the OSPM controls section.
- Delivered performance may be lower than the OSPM desired performance if the platform's efficiency optimizations caused the delivered performance to be less than desired performance. However, the delivered performance should never be lower than the OSPM specified Performance Reduction Tolerance. The Performance Reduction Tolerance provides a bound to the platform on how aggressive it can be when optimizing performance delivery. The platform should not perform any optimization that would cause delivered performance to be lower than the OSPM specified Performance Reduction Tolerance.

Reference Performance Counter Register

Attribute:	Read
Size:	32 or 64 bits

The Reference Performance Counter Register counts at a fixed rate any time the processor is active. It is not affected by changes to Desired Performance, processor throttling, etc. If Reference Performance is supported, the Reference Performance Counter accumulates at a rate corresponding to the Reference Performance level. Otherwise, the Reference Performance Counter accumulates at the Nominal performance level.

Delivered Performance Counter Register:

Attribute:	Read
Size:	32 or 64 bits

The Delivered Performance Counter Register increments any time the processor is active, at a rate proportional to the current performance level, taking into account changes to Desired Performance. When the processor is operating at its reference performance level, the delivered performance counter must increment at the same rate as the reference performance counter.

Counter Wraparound Time:

Optional Register or DWORD	Attribute:	Read
Size:		32 or 64 bits
Units:		seconds

Counter Wraparound Time provides a means for the platform to specify a rollover time for the Reference/Delivered performance counters. If greater than this time period elapses between OSPM querying the feedback counters, the counters may wrap without OSPM being able to detect that they have done so.

If not implemented (or zero), the performance counters are assumed to never wrap during the lifetime of the platform.

8.4.6.1.3.2 Performance Limited Register

Attribute:	Read/Write
Size:	>=2 bit(s)

In the event that the platform constrains the delivered performance to less than the minimum performance or the desired performance (or, less than the guaranteed performance, if desired performance is greater than guaranteed performance) due to an unpredictable event, the platform sets the performance limited indicator to a non-zero value. This indicates to OSPM that an unpredictable event has limited processor performance, and the delivered performance may be less than desired / minimum performance. If the platform does not support signaling performance limited events, this register is permitted to always return zero when read.

Table 8.24: Performance Limited Register Status Bits

Bit	Name	Description
0	Desired_Excursion	Set when Delivered Performance has been constrained to less than Desired Performance (or, less than the guaranteed performance, if desired performance is greater than guaranteed performance). This bit is not utilized when Autonomous Selection is enabled.
1	Minimum_Excursion	Set when Delivered Performance has been constrained to less than Minimum Performance
2-n	Reserved	Reserved

Bits within the Performance Limited Register are sticky, and will remain non-zero until OSPM clears the bit. The platform should only issue a Notify when Minimum Excursion transitions from 0 to 1 to avoid repeated events when there is sustained or recurring limiting but OSPM has not cleared the previous indication.

Note: All accesses to the Performance Limited Register must be made using interlocked operations, by both accessing entities.*

The performance limited register should only be used to report short term, unpredictable events (e.g., PROCHOT being asserted). If the platform is capable of identifying longer term, predictable events that limit processor performance, it should use the guaranteed performance register to notify OSPM of this limitation. Changes to guaranteed performance should not be more frequent than once per second. If the platform is not able to guarantee a given performance level for a sustained period of time (greater than one second), it should guarantee a lower performance level and opportunistically enter the higher performance level as requested by OSPM and allowed by current operating conditions.

8.4.6.1.4 CPPC Enable Register

Optional Attribute:	Read/Write
Size:	>=1 bit(s)

If supported by the platform, OSPM writes a one to this register to enable CPPC on this processor.

If not implemented, OSPM assumes the platform always has CPPC enabled.

8.4.6.1.5 Autonomous Selection Enable Register

Optional Register	or	DWORD	Attribute:	Read/Write
Size:				>=1 bit(s)

If supported by the platform, OSPM writes a one to this register to enable Autonomous Performance Level Selection on this processor. CPPC must be enabled via the CPPC Enable Register to enable Autonomous Performance Level Selection. Platforms that exclusively support Autonomous Selection must populate this field as an Integer with a value of 1.

When Autonomous Selection is enabled, the platform is responsible for selecting performance states. OSPM is not required to assess processor workload performance demand and convey a corresponding performance delivery request to the platform via the Desired Performance Register.

8.4.6.1.6 Autonomous Activity Window Register

Optional Attribute:	Read/Write
Size:	10 bit(s)
Units:	Bits 06:00 - Significand, Bits 09:07 - Exponent, Base_Time_Unit = 1E-6 seconds (1_
	↔microsecond)

If supported by the platform, OSPM may write a time value (10^3 -bit exp * 7-bit mantissa in 1μsec units: 1us to 1270 sec) to this field to indicate a moving utilization sensitivity window to the platform's autonomous selection policy. Combined with the Energy Performance Preference Register value, the Activity Window influences the rate of performance increase / decrease of the platform's autonomous selection policy. OSPM writes a zero value to this register to enable the platform to determine an appropriate Activity Window depending on the workload.

Writes to this register only have meaning when Autonomous Selection is enabled.

8.4.6.1.7 Energy Performance Preference Register

Optional Attribute:	Read/Write
Size:	4-8 bit(s)

If supported by the platform, OSPM may write a range of values from 0 (performance preference) to 0xFF (energy efficiency preference) that influences the rate of performance increase /decrease and the result of the hardware's energy efficiency and performance optimization policies. This provides a means for OSPM to limit the energy efficiency impact of the platform's performance-related optimizations / control policy and the performance impact of the platform's energy efficiency-related optimizations / control policy.

Writes to this register only have meaning when Autonomous Selection is enabled.

8.4.6.1.8 OSPM Control Policy

8.4.6.1.8.1 In-Band Thermal Control

A processor using performance controls may be listed in a thermal zone's `_PSL` list. If it is and the thermal zone engages passive cooling as a result of passing the `_PSV` threshold, OSPM will apply the $\Delta P[\%]$ to modify the value in the desired performance register. Any time that passive cooling is engaged, OSPM must also set the maximum performance register equal to the desired performance register, to enforce the platform does not exceed the desired performance opportunistically.

Note: In System-on-Chip-based platforms where the SoC is comprised of multiple device components in addition to the processor, OSPM's use of the Desired and Maximum registers for thermal control may not produce an optimal result because of SoC device interaction. The use of proprietary package level thermal controls (if they exist) may produce more optimal results.

8.4.6.1.9 Using PCC Registers

If the PCC register space is used, then all PCC registers for all processors in the same performance domain (as defined by `_PSD`), must be defined to be in the same subspace. If `_PSD` is not used, the restriction applies to all registers within a given `_CPC` object.

OSPM will write registers by filling in the register value and issuing a PCC write command. It may also read static registers, counters, and the performance limited register by issuing a read command (see Table 8.25).

To amortize the cost of PCC transactions, OSPM should read or write all PCC registers via a single read or write command when possible.

Table 8.25: PCC Command Codes Used by Collaborative Processor Performance Control

Command	Description
0x00	Read registers. Executed to request the platform update all registers for all enabled processors with their current value.
0x01	Write registers. Executed to notify the platform one or more read/write registers for an enabled processor has been updated.
0x02-0xFF	All other values are reserved.

8.4.6.1.10 Relationship to other ACPI-defined Objects and Notifications

If `_CPC` is present, its use supersedes the use of the following existing ACPI objects:

- The `P_BLK P_CNT` register
- `_PTC`
- `_TSS`
- `_TPC`
- `_TSD`
- `_TDL`
- `_PCT`
- `_PSS`

- `_PPC`
- `_PDL`
- Notify 0x80 on the processor device
- Notify 0x82 on the processor device

The `_PSD` object may be used to specify domain dependencies between processors. On a system with heterogeneous processors, all processors within a single domain must have the same performance capabilities.

8.4.6.1.11 `_CPC` Implementation Example

This example shows a two processor implementation of the `_CPC` interface via the PCC interface, in PCC subspace 2. This implementation uses registers to describe the processor's capabilities, and does not support the Minimum Performance, Maximum Performance, or Time Window registers.

```
Processor (\_SB.CPU0, 1, 0, 0)
{
  Name(_CPC, Package()
  {
    21, // NumEntries
    2, // Revision
    ResourceTemplate() {Register(PCC, 32, 0, 0x120, 2)},
      // Highest Performance
    ResourceTemplate() {Register(PCC, 32, 0, 0x124, 2)},
      // Nominal Performance
    ResourceTemplate() {Register(PCC, 32, 0, 0x128, 2)},
      // Lowest Nonlinear Performance
    ResourceTemplate() {Register(PCC, 32, 0, 0x12C, 2)},
      // Lowest Performance
    ResourceTemplate() {Register(PCC, 32, 0, 0x130, 2)},
      // Guaranteed Performance Register
    ResourceTemplate() {Register(PCC, 32, 0, 0x110, 2)},
      // Desired Performance Register
    ResourceTemplate() {Register(SystemMemory, 0, 0, 0, 0)},
      // Minimum Performance Register
    ResourceTemplate() {Register(SystemMemory, 0, 0, 0, 0)},
      // Maximum Performance Register
    ResourceTemplate() {Register(SystemMemory, 0, 0, 0, 0)},
      // Performance Reduction Tolerance Register
    ResourceTemplate() {Register(SystemMemory, 0, 0, 0, 0)},
      // Time Window Register
    ResourceTemplate() {Register(PCC, 8, 0, 0x11B, 2)},
      // Counter Wraparound Time
    ResourceTemplate() {Register(PCC, 32, 0, 0x114, 2)},
      // Reference Performance Counter Register
    ResourceTemplate() {Register(PCC, 32, 0, 0x116, 2)},
      // Delivered Performance Counter Register
    ResourceTemplate() {Register(PCC, 8, 0, 0x11A, 2)},
      // Performance Limited Register
    ResourceTemplate() {Register(PCC, 1, 0, 0x100, 2)},
      // CPPC Enable Register
    ResourceTemplate() {Register(SystemMemory, 0, 0, 0, 0)},
      // Autonomous Selection Enable
    ResourceTemplate() {Register(SystemMemory, 0, 0, 0, 0)},
      // Autonomous Activity Window Register
    ResourceTemplate() {Register(SystemMemory, 0, 0, 0, 0)},
```

(continues on next page)

(continued from previous page)

```

        // Energy Performance Preference Register
        ResourceTemplate() {Register(SystemMemory, 0, 0, 0, 0)}
        // Reference Performance
    })
}

Processor (\_SB.CPU1, 2, 0, 0)
{
    Name(_CPC, Package()
    {
        21, // NumEntries
        2, // Revision
        ResourceTemplate() {Register(PCC, 32, 0, 0x220, 2)},
            // Highest Performance
        ResourceTemplate() {Register(PCC, 32, 0, 0x224, 2)},
            // Nominal Performance
        ResourceTemplate() {Register(PCC, 32, 0, 0x228, 2)},
            // Lowest Nonlinear Performance
        ResourceTemplate() {Register(PCC, 32, 0, 0x22C, 2)},
            // Lowest Performance
        ResourceTemplate() {Register(PCC, 32, 0, 0x230, 2)},
            // Guaranteed Performance Register
        ResourceTemplate() {Register(PCC, 32, 0, 0x210, 2)},
            // Desired Performance Register
        ResourceTemplate() {Register(SystemMemory, 0, 0, 0, 0)},
            // Minimum Performance Register
        ResourceTemplate() {Register(SystemMemory, 0, 0, 0, 0)},
            // Maximum Performance Register
        ResourceTemplate() {Register(SystemMemory, 0, 0, 0, 0)},
            // Performance Reduction Tolerance Register
        ResourceTemplate() {Register(SystemMemory, 0, 0, 0, 0)},
            // Time Window Register
        ResourceTemplate() {Register(PCC, 8, 0, 0x21B, 2)},
            // Counter Wraparound Time
        ResourceTemplate() {Register(PCC, 32, 0, 0x214, 2)},
            // Reference Performance Counter Register
        ResourceTemplate() {Register(PCC, 32, 0, 0x216, 2)},
            // Delivered Performance Counter Register
        ResourceTemplate() {Register(PCC, 8, 0, 0x21A, 2)},
            // Performance Limited Register
        ResourceTemplate() {Register(PCC, 1, 0, 0x200, 2)},
            // CPPC Enable Register
        ResourceTemplate() {Register(SystemMemory, 0, 0, 0, 0)},
            // Autonomous Selection Enable
        ResourceTemplate() {Register(SystemMemory, 0, 0, 0, 0)},
            // Autonomous Activity Window Register
        ResourceTemplate() {Register(SystemMemory, 0, 0, 0, 0)},
            // Energy Performance Preference Register
        ResourceTemplate() {Register(SystemMemory, 0, 0, 0, 0)}
            // Reference Performance
    })
}

```

8.4.7 _PPE (Polling for Platform Errors)

This optional object, when present, is evaluated by OSPM to determine if the processor should be polled to retrieve corrected platform error information. This object augments /overrides information provided in the CPEP, if supplied. See *Corrected Platform Error Polling Table (CPEP)*.

Arguments:

None

Return Value:

An Integer containing the recommended polling interval in milliseconds.

0 - OSPM should not poll this processor.

Other values - OSPM should poll this processor at \leq the specified interval.

OSPM evaluates the _PPE object during processor object initialization and Bus Check notification processing.

8.5 Processor Aggregator Device

The following section describes the definition and operation of the optional Processor Aggregator device. The Processor Aggregator Device provides a control point that enables the platform to perform specific processor configuration and control that applies to all processors in the platform.

The Plug and Play ID of the Processor Aggregator Device is ACPI000C.

Table 8.26: Processor Aggregator Device Objects

Object	Description
_PUR	Requests a number of logical processors to be placed in an idle state

8.5.1 Logical Processor Idling

In order to reduce the platform's power consumption, the platform may direct OSPM to remove a logical processor from the operating system scheduler's list of processors where non-processor affinitized work is dispatched. This capability is known as Logical Processor Idling and provides a means to reduce platform power consumption without undergoing processor ejection / insertion processing overhead. Interrupts directed to a logical processor and processor affinitized workloads will impede the effectiveness of logical processor idling in reducing power consumption as OSPM is not expected to re-target this work when a logical processor is idled.

8.5.1.1 _PUR (Processor Utilization Request)

The _PUR object is an optional object that may be declared under the Processor Aggregator Device and provides a means for the platform to indicate to OSPM the number of logical processors to be idled. OSPM evaluates the _PUR object as a result of the processing of a Notify event on the Processor Aggregator device object of type 0x80.

Arguments:

None

Return Value:

A Package as described below.

Return Value Information

```

Package
{
    RevisionID // Integer: Current value is 1
    NumProcessors // Integer
}

```

The NumProcessors package element conveys the number of logical processors that the platform wants OSPM to idle. This number is an absolute value. OSPM increments or decrements the number of logical processors placed in the idle state to equal the NumProcessors value as possible. A NumProcessors value of zero causes OSPM to place all logical processor in the active state as possible.

OSPM uses internal logical processor to physical core and package topology knowledge to idle logical processors successively in an order that maximizes power reduction benefit from idling requests. For example, all SMT threads constituting logical processors on a single processing core should be idled to allow the core to enter a low power state before idling SMT threads constituting logical processors on another core.

8.5.2 OSPM _OST Evaluation

When processing of the _PUR object evaluation completes, OSPM evaluates the _OST object, if present under the Processor Aggregator device, to convey _PUR evaluation status to the platform. _OST arguments specific to _PUR evaluation are described below.

Arguments: (3)

Arg0 - Source Event (Integer) : 0x80

Arg1 - Status Code (Integer) : see below

Arg2 - Idled Procs (Buffer) : see below

Return Value:

None

Argument Information:

Arg1 - Status Code:

0 -success - OSPM idled the number of logical processors indicated by the value of Arg2

1: no action was performed

Arg2 - A 4-byte buffer that represents a DWORD that is the number of logical processors that are now idled)

The platform may request a number of logical processors to be idled that exceeds the available number of logical processors that can be idled from an OSPM context for the following reasons:

- The requested number is larger than the number of logical processors currently defined.
- Not all the defined logical processors were online by the OS (for example. for licensing reasons)

Logical processors critical to OS function (for example, the BSP) cannot be idled.

ACPI-DEFINED DEVICES AND DEVICE-SPECIFIC OBJECTS

This chapter describes ACPI defined devices and device-specific objects, plus the system status indicator objects declared under the `_SI` scope in the ACPI Namespace.

9.1 Device Object Name Collision

Devices containing both `_HID` and `_CID` may have device specific control methods pertaining to both the device ID in the `_HID` and the device ID in the `_CID`. These device specific control methods are defined by the device owner (a standard body or a vendor or a group of vendor partners). Since these object names are not controlled by a central authority, there is a likelihood that the names of objects will conflict between two defining parties. The `_DSM` object described in the next section solves this conflict.

9.1.1 `_DSM` (Device Specific Method)

This optional object is a control method that enables devices to provide device specific control functions that are consumed by the device driver.

Arguments: (4)

- Arg0 - A Buffer containing a UUID
- Arg1 - An Integer containing the Revision ID
- Arg2 - An Integer containing the Function Index
- Arg3 - A Package that contains function-specific arguments

Return Value:

If Function Index = 0, a Buffer containing a function index bitfield. Otherwise, the return value and type depends on the UUID and revision ID (see below).

Argument Information:

- Arg0: UUID - A Buffer containing the 16-byte UUID (see *Universally Unique Identifiers (UUIDs)*)
- Arg1: Revision ID - the function's revision. This revision is specific to the UUID.
- Arg2: Function Index - Represents a specific function whose meaning is specific to the UUID and Revision ID. Function indices should start with 1. Function number zero is a query function (see the special return code defined below).
- Arg3: Function Arguments - a package containing the parameters for the function specified by the UUID, Revision ID and Function Index.

Successive revisions of Function Arguments must be backward compatible with earlier revisions. New UUIDs may also be created by OEMs and IHVs for custom devices and other interface or device governing bodies (e.g. the PCI SIG), as long as the UUID is different from other published UUIDs. Only the issuer of a UUID can authorize a new Function Index, Revision ID or Function Argument for that UUID.

Return Value Information:

If Function Index is zero, the return is a buffer containing one bit for each function index, starting with zero. Bit 0 indicates whether there is support for any functions other than function 0 for the specified UUID and Revision ID. If set to zero, no functions are supported (other than function zero) for the specified UUID and Revision ID. If set to one, at least one additional function is supported. For all other bits in the buffer, a bit is set to zero to indicate if that function index is not supported for the specific UUID and Revision ID. (For example, bit 1 set to 0 indicates that function index 1 is not supported for the specific UUID and Revision ID.)

If the bit representing a particular function index would lie outside of the buffer, it should be assumed to be 0 (that is, not supported).

If Function Index is non-zero, the return is any data object. The type and meaning of the returned data object depends on the UUID, Revision ID, Function Index, and Function Arguments.

Note: For backward compatibility `_DSM` requires that each Revision ID support all of the functions defined by all previous Revision IDs for the same UUID.*

Implementation Note

Since the purpose of the `_DSM` method is to avoid the namespace collision, the implementation of this method shall not use any other method or data object which is not defined in this specification unless its driver and usage is completely under the control of the platform vendor.

Example:

```
// _DSM - Device Specific Method
//
// Arg0: UUID Unique function identifier
// Arg1: Integer Revision Level
// Arg2: Integer Function Index (0 = Return Supported Functions)
// Arg3: Package Parameters
Function(_DSM, {IntObj, BuffObj}, {BuffObj, IntObj, IntObj, PkgObj})
{
    //
    // Switch based on which unique function identifier was passed in
    //
    switch(Arg0)
    {
        //
        // First function identifier
        //
        case(ToUUID("893f00a6-660c-494e-bcfd-3043f4fb67c0"))
        {
            switch(Arg2)
            {
                //
                // Function 0: Return supported functions, based on revision
                //
                case(0)
                {
                    switch(Arg1)
                    {
```

(continues on next page)

(continued from previous page)

```

// revision 0: functions 1-4 are supported
case(0) {return (Buffer() {0x1F})}
// revision 1: functions 1-5 are supported
case(1) {return (Buffer() {0x3F})}
}
// revision 2+: functions 1-7 are supported
return (Buffer() {0xFF})
}
//
// Function 1:
//
case(1)
{
... function 1 code ...
Return(Zero)
}
//
// Function 2:
//
case(2)
{
... function 2 code ...
Return(Buffer() {0x00})
}
case(3) { ... function 3 code ...}
case(4) { ... function 4 code ...}
case(5) { if (LLess(Arg1,1) BreakPoint; ... function 5 code ... }
case(6) { if (LLess(Arg1,2) BreakPoint; ... function 6 code ... )
case(7) { if (LLess(Arg1,3) BreakPoint; ... function 7 code ... )
default {BreakPoint }
}
}
//
// Second function identifier
//
case(ToUUID("107ededd-d381-4fd7-8da9-08e9a6c79644"))
{
//
// Function 0: Return supported functions (there is only one revision)
//
if (LEqual(Arg2,Zero))
return (Buffer() {0x3}) // only one function supported
//
// Function 1
//
if (LEqual(Arg2,One))
{
... function 1 code ...
Return(Unicode("text"))
}
//
// Function 2+: Runtime Error
//
else
BreakPoint;
}
}

```

(continues on next page)

(continued from previous page)

```

//
// If not one of the UUIDs we recognize, then return a buffer
// with bit 0 set to 0 indicating no functions supported.
//
return(Buffer() {0})
}

```

9.2 _SI System Indicators

ACPI provides an interface for a variety of simple and icon-style indicators on a system. All indicator controls are in the _SI portion of the namespace. The following table lists all defined system indicators. (Notice that there are also per-device indicators specified for battery devices).

Table 9.1: System Indicator Control Methods

Object	Description
_SST	System status indicator
_MSG	Messages waiting indicator
_BLT	Battery Level Threshold

9.2.1 _SST (System Status)

This optional object is a control method that OSPM invokes to set the system status indicator as desired.

Arguments:(1)

Arg0 - An Integer containing the system status indicator identifier:

- 0 - No system state indication. Indicator off
- 1 - Working
- 2 - Waking
- 3 - Sleeping. Used to indicate system state S1, S2, or S3
- 4 - Sleeping with context saved to non-volatile storage

Return Value:

None

9.2.2 _MSG (Message)

This control method sets the system's message-waiting status indicator.

Arguments:(1)

Arg0 - An Integer containing the number of waiting messages

Return Value:

None

9.2.3 _BLT (Battery Level Threshold)

This optional control method is used by OSPM to indicate to the platform the user's preference for various battery level thresholds. This method allows platform battery indicators to be synchronized with OSPM provided battery notification levels. Note that if _BLT is implemented on a multi-battery system, it is required that the power unit for all batteries must be the same (see Section 10.2 for more details on battery levels).

Arguments:(3)

Arg0 - An Integer containing the preferred threshold for the battery warning level

Arg1 - An Integer containing the preferred threshold for the battery low level

Arg2 - An Integer containing the preferred threshold for the battery wake level

Return Value:

None

Additional Information

The battery warning level in the range 0x00000001 - 0x7FFFFFFF (in units of mWh or mAh, depending on the Power Units value) is the user's preference for battery warning. If the level specified is less than the design capacity of warning, it may be ignored by the platform so that the platform can ensure a successful wake on low battery.

The battery low level in the range 0x00000001 - 0x7FFFFFFF (in units of mWh or mAh, depending on the Power Units value) is the user's preference for battery low. If this level is less than the design capacity of low, it may be ignored by the platform.

The battery wake level in the range 0x00000001 - 0x7FFFFFFF (in units of mWh or mAh, depending on the Power Units value) is the user's preference for battery wake. If this level is less than the platform's current wake on low battery level, it may be ignored by the platform. If the platform does not support a configurable wake on low battery level, this may be ignored by the platform.

9.3 Ambient Light Sensor Device

The following section illustrates the operation and definition of the control method-based Ambient Light Sensor (ALS) device.

The ambient light sensor device can optionally support power management objects (e.g. _PS0, _PS3) to allow the OS to manage the device's power consumption.

The Plug and Play ID of an ACPI control method ambient light sensor device is ACPI0008.

Table 9.2: Control Method Ambient Light Sensor Device

Object	Description
_ALI	The current ambient light illuminance reading in lux (lumen per square meter). [Required]
_ALC	The current ambient light color chromaticity reading, specified using x and y coordinates per the CIE Yxy color model. [Optional]
_ALT	The current ambient light color temperature reading in degrees Kelvin. [Optional]
_ALR	Returns a set of ambient light illuminance to display brightness mappings that can be used by an OS to calibrate its ambient light policy. [Required]
_ALP	Ambient light sensor polling frequency in tenths of seconds. [Optional]

9.3.1 Overview

This definition provides a standard interface by which the OS may query properties of the ambient light environment the system is currently operating in, as well as the ability to detect meaningful changes in these values when the environment changes. Two ambient light properties are currently supported by this interface: illuminance and color.

Ambient light illuminance readings are obtained via the `_ALI` method. Illuminance readings indicate the amount of light incident upon (falling on) a specified surface area. Values are specified in lux (lumen per square meter) and give an indication of how “bright” the environment is. For example, an overcast day is roughly 1000 lux, a typical office environment 300-400 lux, and a dimly-lit conference room around 10 lux.

A possible use of ambient light illuminance data by the OS is to automatically adjust the brightness (or luminance) of the display device - e.g. increase display luminance in brightly-lit environments and decrease display luminance in dimly-lit environments. Note that Luminance is a measure of light radiated (reflected, transmitted, or emitted) by a surface, and is typically measured in nits. The `_ALR` method provides a set of ambient light illuminance to display luminance mappings that can be used by an OS to calibrate its policy for a given platform configuration.

Ambient light color readings are obtained via the `_ALT` and/or `_ALC` methods. Two methods are defined to allow varying types/complexities of ambient light sensor hardware to be used. `_ALT` returns color temperature readings in degrees Kelvin. Color temperature values correlate a light source to a standard black body radiator and give an indication of the type of light source present in a given environment (e.g. daylight, fluorescent, incandescent). `ALC` returns color chromaticity readings per the CIE Y_{xy} color model. Chromaticity x and y coordinates provide a more straightforward indication of ambient light color characteristics. Note that the CIE Y_{xy} color model is defined by the International Commission on Illumination (abbreviated as CIE from its French title Commission Internationale de l’Eclairage) and is based on human perception instead of absolute color.

A possible use of ambient light color data by the OS is to automatically adjust the color of displayed images depending on the environment the images are being viewed in. This may be especially important for reflective/transflective displays where the type of ambient light may have a large impact on the colors perceived by the user.

9.3.2 `_ALI` (Ambient Light Illuminance)

This control method returns the current ambient light illuminance reading in lux (lumen per square meter). Expected values range from ~1 lux for a dark room, ~300 lux for a typical office environment, and 10,000+ lux for daytime outdoor environments - although readings may vary depending on the location of the sensor to the light source. Special values are reserved to indicate out of range conditions (see below).

Arguments:

None

Return Value:

An Integer containing the ambient light brightness in lux (lumens per square meter)

0 - The current reading is below the supported range or sensitivity of the sensor.

Ones (-1) - The current reading is above the supported range or sensitivity of the sensor.

Other values - The current ambient light brightness in lux (lumens per square meter)

9.3.3 **_ALT (Ambient Light Temperature)**

This optional control method returns the current ambient light color temperature reading in degrees Kelvin (°K). Lower color temperatures imply warmer light (emphasis on yellow and red); higher color temperatures imply a colder light (emphasis on blue). This value can be used to gauge various properties of the lighting environment - for example, the type of light source. Expected values range from ~1500°K for candlelight, ~3000°K for a 200-Watt incandescent bulb, and ~5500°K for full sunlight on a summer day - although readings may vary depending on the location of the sensor to the light source. Special values are reserved to indicate out of range conditions (see below).

Arguments:

None

Return Value:

An Integer containing the ambient light temperature in degrees Kelvin

0 - The current reading is below the supported range or sensitivity of the sensor

Ones (-1) - The current reading is above the supported range or sensitivity of the sensor

Other values - The current ambient light temperature in degrees Kelvin

9.3.4 **_ALC (Ambient Light Color Chromaticity)**

This optional control method returns the current ambient light color chromaticity readings per the CIE Yxy color model. The x and y (chromaticity) coordinates are specified using a fixed 10-4 notation due to the lack of floating point values in ACPI. Valid values are within the range 0 (0x0000) through 1 (0x2710). A single 32-bit integer value is used, where the x coordinate is stored in the high word and the y coordinate in the low word. For example, the value 0x0C370CDA would be used to specify the white point for the CIE Standard Illuminant D65 (a standard representation of average daylight) with x = 0.3127 and y = 0.3290. Special values are reserved to indicate out of range conditions (see below).

Arguments:

None

Return Value:

An Integer containing the ambient light temperature in degrees Kelvin

0 - The current reading is below the supported range or sensitivity of the sensor

Ones (-1) - The current reading is above the supported range or sensitivity of the sensor

Other values - The current ambient light color chromaticity x and y coordinate values, per the CIE Yxy color model

9.3.5 **_ALR (Ambient Light Response)**

This object evaluates to a package of ambient light illuminance to display luminance mappings that can be used by an OS to calibrate its ambient light policy for a given sensor configuration. The OS can use this information to extrapolate an ALS response curve - noting that these values may be treated differently depending on the OS implementation but should be used in some form to calibrate ALS policy.

Arguments:

None

Return Value:

A variable-length Package containing a list of luminance mapping Packages. Each mapping package consists of two Integers.

The return data is specified as a package of packages, where each tuple (inner package) consists of the pair of Integer values of the form:

```
{<display luminance adjustment>, <ambient light illuminance>}
```

Package elements should be listed in monotonically increasing order based upon the ambient light illuminance value (the Y-coordinate on the graph) to simplify parsing by the OS.

Ambient light illuminance values are specified in lux (lumens per square meter). Display luminance (or brightness) adjustment values are specified using relative percentages in order to simplify the means by which these adjustments are applied in lieu of changes to the user's display brightness preference. A value of 100 is used to indicate no (0%) display brightness adjustment given the lack of signed data types in ACPI. Values less than 100 indicate a negative adjustment (dimming); values greater than 100 indicate a positive adjustment (brightening). For example, a display brightness adjustment value of 75 would be interpreted as a -25% adjustment, and a value of 110 as a +10% adjustment.

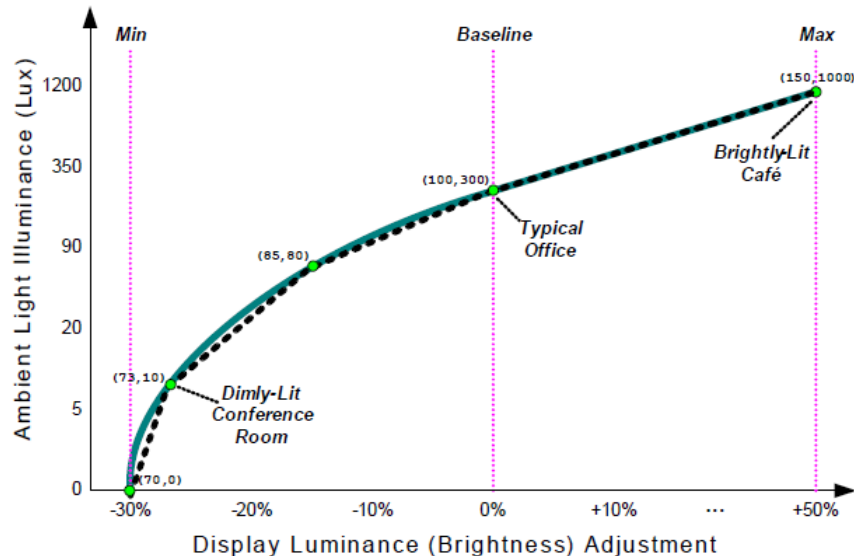

Fig. 9.1: A five-point ALS Response Curve

The figure above illustrates the use of five points to approximate an example response curve, where the dotted line represents an approximation of the desired response (solid curve). Extrapolation of the values between these points is OS-specific - although for the purposes of this example we'll assume a piecewise linear approximation. The ALS response curve (`_ALR`) would be specified as follows:

```
Name (_ALR, Package () {
  Package {70, 0}, // Min ( -30% adjust at 0 lux)
  Package {73, 10}, // ( -27% adjust at 10 lux)
  Package {85, 80}, // ( -15% adjust at 80 lux)
  Package {100, 300}, // Baseline ( 0% adjust at 300 lux)
  Package {150, 1000} // Max ( +50% adjust at 1000 lux)
})
```

Within this data set exist three points of particular interest: baseline, min, and max. The baseline value represents an ambient light illuminance value (in lux) for the environment where this system is most likely to be used. When

the system is operating in this ambient environment the ALS policy will apply no (0%) adjustment to the default display brightness setting. For example, given a system with a 300 lux baseline, operating in a typical office ambient environment (~300 lux), configured with a default display brightness setting of 50% (e.g. 60 nits), the ALS policy would apply no backlight adjustment, resulting in an absolute display brightness setting of 60 nits.

Min and max are used to indicate cutoff points in order to prevent an over-zealous response by the ALS policy and to influence the policy's mode of operation. For example, the min and max points from the figure above would be specified as (70,0) and (150,1000) respectively - where min indicates a maximum negative adjustment of 30% and max represents a maximum positive adjustment of 50%. Using a large display brightness adjustment for max allows an ALS response that approaches a fully-bright display (100% absolute) in very bright ambient environments regardless of the user's display brightness preference. Using a small value for max (e.g. 0% @ 300 lux) would influence the ALS policy to limit the use of this technology solely as a power-saving feature (never brighten the display). Conversely, setting min to a 0% adjustment instructs ALS policy to brighten but never dim.

A minimum of two data points are required in the return package, interpreted as min and max. Note that the baseline value does not have to be explicitly stated; it can be derived from the response curve. Addition elements can be provided to fine-tune the response between these-points. The following figure illustrates the use of two data points to achieve a response similar to (but simpler than) that described in the five-point ALS response curve example.

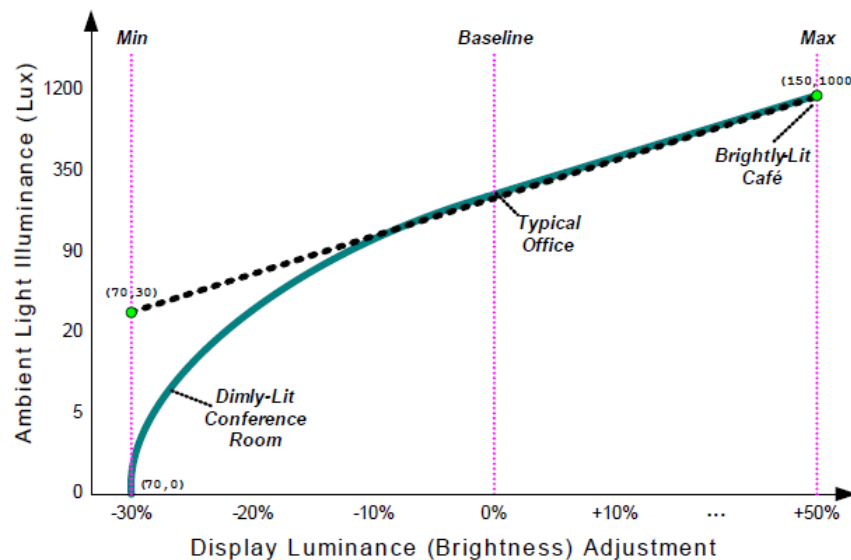

Fig. 9.2: A two-point ALS Response Curve

This example lacks an explicit baseline and includes a min with an ambient light value above 0 lux. The baseline can easily be extrapolated by ALS Policy (e.g. 0% adjustment at ~400 lux). All ambient light brightness settings below min (20 lux) would be treated in a similar fashion by ALS policy (e.g. -30% adjustment). This two-point response curve would be modeled as:

```
Name(_ALR, Package() {
    Package{70, 30}, // Min (-30% adjust at 30 lux)
    Package{150, 1000} // Max (+50% adjust at 1000 lux)
})
```

This model can be used to convey a wide range of ambient light to display brightness responses. For example, a transfective display - a technology where illumination of the display can be achieved by reflecting available ambient light, but also augmented in dimly-lit environments with a backlight - could be modeled as illustrated in the following figure.

This three-point approximation would result in an ALS response that allows the backlight to increase as the ambient

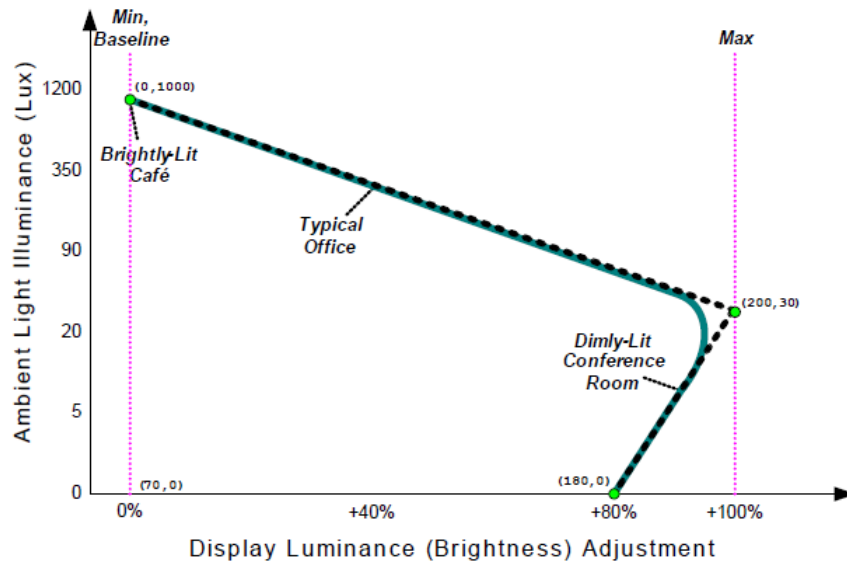

Fig. 9.3: Example Response Curve for a Transflective Display

lighting decreases. In this example, no backlight adjustment is needed in bright environments (1000+ lux), maximum backlight may be needed in dim environments (~30 lux), but a lower backlight setting may be used in a very-dark room (~0 lux) - resulting in an elbow around 30 lux. This response would be modeled in `_ALR` as follows:

```
Name(_ALR, Package() {
    Package{180, 0} ( +80% adjust at 0 lux)
    Package{200, 30}, // Max (+100% adjust at 30 lux)
    Package{0, 1000}, // Min ( 0% adjust at 1,000 lux)
})
```

Note the ordering of package elements: monotonically increasing from the lowest ambient light value (0 lux) to the highest ambient light value (1000 lux).

The transflective display example also highlights the need for non-zero values for the user's display brightness preference - which we'll refer to as the reference display brightness value. This requirement is derived from the model's use of relative adjustments. For example, applying any adjustment to a 0% reference display brightness value always results in a 0% absolute display brightness setting. Likewise, using a very small reference display brightness (e.g. 5%) results in a muted response (e.g. +30% of 5% = 6.5% absolute). The solution is to apply a reasonably large value (e.g. 50%) as the reference display brightness setting - even in the case where no backlight is applied. This allows relative adjustments to be applied in a meaningful fashion while conveying to the user that the display is still usable (via reflected light) under typical ambient conditions.

The OS derives the user's display brightness preference (this reference value) either from the Brightness Control Levels (`_BCL`) object or another OS-specific mechanism (see [Section 9.3.8](#)).

9.3.6 `_ALP` (Ambient Light Polling)

This optional object evaluates to a recommended polling frequency (in tenths of seconds) for this ambient light sensor. A value of zero - or the absence of this object when other ALS objects are defined - indicates that OSPM does not need to poll the sensor in order to detect meaningful changes in ambient light (the hardware is capable of generating asynchronous notifications).

The use of polling is allowed but strongly discouraged by this specification. OEMs should design systems that asynchronously notify OSPM whenever a meaningful change in the ambient light occurs—relieving the OS of the overhead associated with polling.

This value is specified as tenths of seconds. For example, a value of 10 would be used to indicate a 1 second polling frequency. As this is a recommended value, OSPM will consider other factors when determining the actual polling frequency to use.

Arguments:

None

Return Value:

An Integer containing the recommended polling frequency in tenths of seconds

0 - Polling by the host OS is not required

Other - The recommended polling frequency in tenths of seconds

9.3.7 Ambient Light Sensor Events

To communicate meaningful changes in ALS illuminance to OSPM, AML code should issue a `Notify(als_device, 0x80)` whenever the lux reading changes more than 10% (from the last reading that resulted in a notification). OSPM receives this notification and evaluates the `_ALI` control method to determine the current ambient light status. The OS then adjusts the display brightness based upon its ALS policy (derived from `_ALR`).

The definition of what constitutes a meaningful change is left to the system integrator, but should be at a level of granularity that provides an appropriate response without overly taxing the system with unnecessary interrupts. For example, an ALS configuration may be tuned to generate events for all changes in ambient light illuminance that result in a minimum $\pm 5\%$ display brightness response (as defined by `_ALR`).

To communicate meaningful changes in ALS color temperature to OSPM, AML code should issue a `Notify(als_device, 0x81)` whenever the lux reading changes more than 10% (from the last reading that resulted in a notification). OSPM receives this notification and evaluates the `_ALT` and `_ALC` control method to determine the current ambient light color temperature.

To communicate meaningful changes in ALS response to OSPM, AML code should issue a `Notify(als_device, 0x82)` whenever the set of points used to convey ambient light response has changed. OSPM receives this notification and evaluates the `_ALR` object to determine the current response points.

9.3.8 Relationship to Backlight Control Methods

The Brightness Control Levels (`_BCL`) method - described in section 0 - can be used to indicate user-selectable display brightness levels. The information provided by this method indicates the available display brightness settings, the recommended default brightness settings for AC and DC operation, and the absolute maximum and minimum brightness settings. These values indirectly influence the operation of the OSPM's ALS policy.

Display brightness adjustments produced by ALS policy are relative to the current user backlight setting, and the resulting absolute value must be mapped (rounded) to one of the levels specified in `_BCL`. This introduces the requirement for fine-grain display brightness control in order to achieve a responsive ALS system - which typically materializes as a need for additional entries in the `_BCL` list in order to provide reasonable resolution to the OS (e.g. 3-10% granularity). Note that user brightness controls (e.g. hotkeys) are not required to make use of all levels specified in `_BCL`.

9.4 Control Method Lid Device

Platforms containing lids convey lid status (open / closed) to OSPM using a Control Method Lid Device.

To implement a control method lid device, AML code should issue a `Notify(lid_device, 0x80)` for the device whenever the lid status has changed. The `_LID` control method for the lid device must be implemented to report the current state of the lid as either opened or closed.

The lid device can support `_PRW` and `_PSW` methods to select the wake functions for the lid when the lid transitions from closed to opened.

The Plug and Play ID of an ACPI control method lid device is `PNP0C0D`.

Table 9.3: Control Method Lid Device

Object	Description
<code>_LID</code>	Returns the current status of the lid.

9.4.1 `_LID`

Evaluates to the current status of the lid.

Arguments:

None

Return Value:

An Integer containing the current lid status:

0 - The lid is closed
Non-zero - The lid is open

9.5 Control Method Power and Sleep Button Devices

The system's power or sleep button can either be implemented using the fixed register space as defined in *Console Buttons* or implemented in AML code as a control method power button device. In either case, the power button override function or similar unconditional system power or reset functionality is still implemented in external hardware.

To implement a control method power-button or sleep-button device, implement AML code that delivers two types of notifications concerning the device. The first is `Notify(Object, 0x80)` to signal that the button was pressed while the system was in the S0 state to indicate that the user wants the machine to transition from S0 to some sleeping state. The other notification is `Notify(Object, 0x2)` to signal that the button was pressed while the system was in an S1 to S4 state and to cause the system to wake. When the button is used to wake the system, the wake notification (`Notify(Object, 0x2)`) must occur after OSPM actually wakes, and a button-pressed notification (`Notify(Object, 0x80)`) must not occur.

The Wake Notification indicates that the system is awake because the user pressed the button and therefore a complete system resume should occur (for example, turn on the display immediately, and so on).

9.6 Generic Container Device

A generic container device is a bridge that does not require a special OS driver because the bridge does not provide or require any features not described within the normal ACPI device functions. The resources the bridge requires are specified via normal ACPI resource mechanisms. Device enumeration for child devices is supported via ACPI namespace device enumeration and OS drivers require no other features of the bus. Such a bridge device is identified with the Plug and Play ID of PNP0A05 or PNP0A06.

A generic bus bridge device is typically used for integrated bridges that have no other means of controlling them and that have a set of well-known devices behind them. For example, a portable computer can have a "generic bus bridge" known as an EIO bus that bridges to some number of Super-I/O devices. The bridged resources are likely to be positively decoded as either a function of the bridge or the integrated devices. In this example, a generic bus bridge device would be used to declare the bridge then child devices would be declared below the bridge; representing the integrated Super-I/O devices.

9.7 ATA Controller Devices

There are two types of ATA Controllers: IDE controllers (also known as ATA controllers) and Serial ATA (SATA) controllers. IDE controllers are those using the traditional IDE programming interface, and may support Parallel ATA (P-ATA) or SATA connections. SATA controllers may be designed to operate in emulation mode only, native mode only, or they may be designed to support both native and non-native SATA modes. Regardless of the mode supported, SATA controllers are designed to work solely with drives supporting the Serial ATA physical interface. As described below, SATA controllers are treated similarly but not identically to traditional IDE controllers.

Platforms that contain controllers that support native and non-native SATA modes must take steps to ensure the proper objects are placed in the namespace for the mode in which they are operating.

Table 9.4: ATA Specific Objects

Object	Description	Controller Type
<code>_GTF</code>	Optional object that returns the ATA task file needed to re-initialize the drive to boot up defaults.	Both
<code>_GTM</code>	Optional object that returns the IDE controller timing information.	IDE-only
<code>_STM</code>	Optional control method that sets the IDE controller's transfer timing settings.	IDE-only

continues on next page

Table 9.4 – continued from previous page

Object	Description	Controller Type
_SDD	Optional control method that informs the platform of the type of device attached to a port.	SATA-only

9.7.1 Objects for Both ATA and SATA Controllers

9.7.1.1 _GTF (Get Task File)

This optional object returns a buffer containing the ATA commands used to restore the drive to boot up defaults (that is, the state of the drive after POST). The returned buffer is an array with each element in the array consisting of seven 8-bit register values (56 bits) corresponding to ATA task registers 1F1 thru 1F7. Each entry in the array defines a command to the drive.

Arguments:

None

Return Value:

A Buffer containing a byte stream of ATA commands for the drive

This object may appear under SATA port device objects or under IDE channel objects.

ATA task file array definition:

- Seven register values for command 1
 - Reg values: (1F1, 1F2, 1F3, 1F4, 1F5, 1F6, 1F7)
- Seven register values for command 2
 - Reg values: (1F1, 1F2, 1F3, 1F4, 1F5, 1F6, 1F7)
- Seven register values for command 3
 - Reg values: (1F1, 1F2, 1F3, 1F4, 1F5, 1F6, 1F7)
- Etc.

After powering up the drive, OSPM will send these commands to the drive, in the order specified. On SATA HBAs, OSPM evaluates _SDD before evaluating _GTF. The IDE driver may modify some of the feature commands or append its own to better tune the drive for OSPM features before sending the commands to the drive.

This Control Method is listed under each drive device object. OSPM must evaluate the _STM object or the _SDD object before evaluating the _GTF object.

Example of the return from _GTF:

```
Method(_GTF, 0x0, NotSerialized)
{
    Return(GTF0)
}
Name(GTF0, Buffer(0x1c)
{
    0x03, 0x00, 0x00, 0x00, 0x00, 0xa0, 0xef, 0x03, 0x00, 0x00, 0x00, 0x00,
    0xa0, 0xef, 0x00, 0x10, 0x00, 0x00, 0x00, 0xa0, 0xc6, 0x00, 0x00, 0x00,
    0x00, 0x00, 0xa0, 0x91
})
```

9.7.2 IDE Controller Device

Most device drivers can save and restore the registers of their device. For IDE controllers and drives, this is not true because there are several drive settings for which ATA does not provide mechanisms to read. Further, there is no industry standard for setting timing information for IDE controllers. Because of this, ACPI interface mechanisms are necessary to provide the operating system information about the current settings for the drive and channel, and for setting the timing for the channel.

OSPM and the IDE driver will follow these steps when powering off the IDE subsystem:

1. The IDE driver will call the `_GTM` control method to get the current transfer timing settings for the IDE channel. This includes information about DMA and PIO modes.
2. The IDE driver will call the standard OS services to power down the drives and channel.
3. As a result, OSPM will execute the appropriate `_PS3` methods and turn off unneeded power resources.

To power on the IDE subsystem, OSPM and the IDE driver will follow these steps:

1. The IDE driver will call the standard OS services to turn on the drives and channel.
2. As a result, OSPM will execute the appropriate `_PS0` methods and turn on required power resources.
3. The IDE driver will call the `_STM` control method passing in transfer timing settings for the channel, as well as the ATA drive ID block for each drive on the channel. The `_STM` control method will configure the IDE channel based on this information.
4. For each drive on the IDE channel, the IDE driver will run the `_GTF` to determine the ATA commands required to reinitialize each drive to boot up defaults.
5. The IDE driver will finish initializing the drives by sending these ATA commands to the drives, possibly modifying or adding commands to suit the features supported by the operating system.

The following shows the namespace for these objects:

```

\_SB                                // System bus
  PCI0                              // PCI bus
    IDE1                             // First IDE channel
      _ADR                          // Indicates address of the channel on the PCI bus
      _GTM                          // Control method to get current IDE channel settings
      _STM                          // Control method to set current IDE channel settings
      _PR0                          // Power resources needed for D0 power state
      DRV1                          // Drive 0
        _ADR                        // Indicates address of master IDE device
        _GTF                        // Control method to get task file
      DRV2                          // Drive 1
        _ADR                        // Indicates address of slave IDE device
        _GTF                        // Control method to get task file
    IDE2                             // Second IDE channel
      _ADR                          // Indicates address of the channel on the PCI bus
      _GTM                          // Control method to get current IDE channel settings
      _STM                          // Control method to set current IDE channel settings
      _PR0                          // Power resources needed for D0 power state
      DRV1                          // Drive 0
        _ADR                        // Indicates address of master IDE device
        _GTF                        // Control method to get task file
      DRV2                          // Drive 1
        _ADR                        // Indicates address of slave IDE device
        _GTF                        // Control method to get task file

```

The sequential order of operations is as follows:

Powering down

- Call `_GTM`.
- Power down drive (calls `_PS3` method and turns off power planes).

Powering up

- Power up drive (calls `_PS0` method if present and turns on power planes).
- Call `_STM` passing info from `_GTM` (possibly modified), with ID data from each drive.
- Initialize the channel.
- May modify the results of `_GTF`.
- For each drive:
 - Call `_GTF`.
 - Execute task file (possibly modified).

9.7.2.1 IDE Controller-specific Objects

9.7.2.1.1 `_GTM` (Get Timing Mode)

This Control Method exists under each channel device object and returns the current settings for the IDE channel.

Arguments:

None

Return Value:

A Buffer containing the current IDE channel timing information block as described in the *GTM Method Result Codes* table below.

`_GTM` returns a buffer with the following format

```
Buffer () {
    PIO Speed 0 //DWORD
    DMA Speed 0 //DWORD
    PIO Speed 1 //DWORD
    DMA Speed 1 //DWORD
    Flags      //DWORD
}
```

Table 9.5: **GTM Method Result Codes**

Field	Format	Description
PIO Speed 0	DWORD	The PIO bus-cycle timing for drive 0 in nanoseconds. 0xFFFFFFFF indicates that this mode is not supported by the channel. If the chipset cannot set timing parameters independently for each drive, this field represents the timing for both drives.
DMA Speed 0	DWORD	The DMA bus-cycle for drive 0 timing in nanoseconds. If bit 0 of the Flags register is set, this DMA timing is for UltraDMA mode, otherwise the timing is for multi-word DMA mode. 0xFFFFFFFF indicates that this mode is not supported by the channel. If the chipset cannot set timing parameters independently for each drive, this field represents the timing for both drives.

continues on next page

Table 9.5 – continued from previous page

Field	Format	Description
PIO Speed 1	DWORD	The PIO bus-cycle timing for drive 1 in nanoseconds. 0xFFFFFFFF indicates that this mode is not supported by the channel. If the chipset cannot set timing parameters independently for each drive, this field must be 0xFFFFFFFF.
DMA Speed 1	DWORD	The DMA bus-cycle timing for drive 1 in nanoseconds. If bit 0 of the Flags register is set, this DMA timing is for UltraDMA mode, otherwise the timing is for multi-word DMA mode. 0xFFFFFFFF indicates that this mode is not supported by the channel. If the chipset cannot set timing parameters independently for each drive, this field must be 0xFFFFFFFF.
Flags	DWORD	Mode flags Bit [0]: 1 indicates using UltraDMA on drive 0 Bit [1]: 1 indicates IOChannelReady is used on drive 0 Bit [2]: 1 indicates using UltraDMA on drive 1 Bit [3]: 1 indicates IOChannelReady is used on drive 1 Bit [4]: 1 indicates chipset can set timing independently for each drive Bits [31:5]: reserved (must be 0)

9.7.2.1.2 _STM (Set Timing Mode)

This Control Method sets the IDE channel’s transfer timings to the setting requested. The AML code is required to convert and set the nanoseconds timing to the appropriate transfer mode settings for the IDE controller. _STM may also make adjustments so that _GTF control methods return the correct commands for the current channel settings.

This control method takes three arguments: Channel timing information (as described in Table 9-6), and the ATA drive ID block for each drive on the channel. The channel timing information is not guaranteed to be the same values as returned by _GTM; the OS may tune these values as needed.

Arguments:(3)

- Arg0 - A Buffer containing a channel timing information block (described in Table 9-6)
- Arg1 - A Buffer containing the ATA drive ID block for channel 0
- Arg2 - A Buffer containing the ATA drive ID block for channel 1

Return Value:

None

The ATA drive ID block is the raw data returned by the Identify Drive ATA command, which has the command code “0ECh.” The _STM control method is responsible for correcting for drives that misreport their timing information.

9.7.3 Serial ATA (SATA) Controller Device

9.7.3.1 Definitions

HBA Host Bus Adapter

Native SATA aware Refers to system software (platform firmware, option ROM, operating system, etc) that comprehends a particular SATA HBA implementation and understands its programming interface and power management behavior.

Non-native SATA aware Refers to system software (platform firmware, option ROM, operating system, etc) that does not comprehend a particular SATA HBA implementation and does not understand its programming interface or power management behavior. Typically, non-native SATA aware software will use a SATA HBA’s emulation interface (e.g. task file registers) to control the HBA and access its devices.

Emulation mode Optional mode supported by a SATA HBA. Allows non-native SATA aware software to access SATA devices via traditional task file registers.

Native mode Optional mode supported by a SATA HBA. Allows native SATA aware software to access SATA devices via registers that are specific to the HBA.

Hybrid Device Refers to a SATA HBA that implements both an emulation and a native programming interface.

9.7.3.2 Overview

A SATA HBA differs from an IDE controller in a number of ways. First, it can save its complete device context. Second, it replaces IDE channels, which may support up to 2 attached devices, with ports, which support only a single attached device, unless a port multiplier is present. See the SATA spec at “Links to ACPI-Related Documents” (<http://uefi.org/acpi>) under the heading “SATA Specification” for more information. Finally, SATA does not require timing information from the platform, allowing a simplification in how SATA controllers are represented in ACPI. (`_GTM` and `_STM` are replaced by the simpler `_SDD` method.)

All ports, even those attached off a port multiplier, are represented as children directly under the SATA controller device. This is practical because the SATA specification does not allow a port multiplier to be attached to a port multiplier. Each port’s `_ADR` indicates to which root port they are connected, as well as the port multiplier location, if applicable (see Table 6.2)

Since this specification only covers the configuration of motherboard devices, it is also the case that the control methods defined in this section cannot be used to send taskfiles to devices attached via either an add-in SATA HBA, or attached via a motherboard SATA HBA, if used with a port multiplier that is not also on the motherboard.

The following shows an example SATA namespace:

```

\_SB - System bus
  PCI0 - PCI bus
    SATA - SATA Controller device
      ADR - Indicates address of the controller on the PCI bus
      PR0 - Power resources needed for D0 power state
      PRT0 - Port 0 device
        _ADR - Indicates physical port and port multiplier topology
        _SDD - Identify information for drive attached to this port
        _GTF - Control method to get task file
      PRTn - Port n device
        _ADR - Indicates physical port and port multiplier topology
        _SDD - Identify information for drive attached to this port
        _GTF - Control method to get task file
  
```

9.7.3.3 SATA controller-specific control methods

In order to ensure proper interaction between OSPM, the firmware, and devices attached to the SATA controller, it is a requirement that OSPM execute the `_SDD` and `_GTF` control methods when certain events occur. OSPM’s response to events must be as follows:

COMRESET, Initial OS load, device insertion, HBA D3 to D0 transition, asynchronous loss of signal:

1. OSPM sends IDENTIFY DEVICE or IDENTIFY PACKET DEVICE command to the attached device.
2. OS executes `_SDD`. `_SDD` control method requires 1 argument that consists of the data block received from an attached device as a result of a host issued IDENTIFY DEVICE or IDENTIFY PACKET DEVICE command.
3. After the `_SDD` method completes, the OS executes the `_GTF` method. Using the task file information provided by `_GTF`, the OS then sends the `_GTF` taskfiles to the attached device.

Device removal and HBA D0 to D3 transition:

1. No OSPM action required.

9.7.3.3.1 _SDD (Set Device Data)

This optional object is a control method that conveys to the platform the type of device connected to the port. The _SDD object may exist under a SATA port device object. The platform typically uses the information conveyed by the _SDD object to construct the values returned by the _GTF object.

OSPM conveys to the platform the ATA drive ID block, which is the raw data returned by the Identify (Packet) Device, ATA command (command code “0ech.”). Please see the ATA/ATAPI-6 specification for more details.

Arguments:(1)

Arg0 - A Buffer containing an ATA drive identify block, contents described by the ATA specification

Return Value:

None

9.8 Floppy Controller Device Objects

9.8.1 _FDE (Floppy Disk Enumerate)

Enumerating devices attached to a floppy disk controller is a time-consuming function. In order to speed up the process of floppy enumeration, ACPI defines an optional enumeration object that is defined directly under the device object for the floppy disk controller. It returns a buffer of five 32-bit values. The first four values are Boolean values indicating the presence or absence of the four floppy drives that are potentially attached to the controller. A non-zero value indicates that the floppy device is present. The fifth value returned indicates the presence or absence of a tape controller. Definitions of the tape presence value can be found in *Tape Presence*.

Arguments:

None

Return Value:

A Buffer containing a floppy drive information block, as described below:

```
Buffer () {
    Floppy 0 // Boolean DWORD
    Floppy 1 // Boolean DWORD
    Floppy 2 // Boolean DWORD
    Floppy 3 // Boolean DWORD
    Tape // DWORD - See the Tape Presence table below
}
```

Table 9.6: **Tape Presence**

Value	Description
0	Device presence is unknown or unavailable
1	Device is present
2	Device is never present
>2	<i>Reserved</i>

9.8.2 _FDI (Floppy Disk Information)

This object returns information about a floppy disk drive. This information is the same as that returned by the INT 13 Function 08H on IA-PCs.

Arguments:

None

Return Value:

A Package containing the floppy disk information as a list of Integers:

```
Package {
  Drive Number // Integer (BYTE)
  Device Type // Integer (BYTE)
  Maximum Cylinder Number // Integer (WORD)
  Maximum Sector Number // Integer (WORD)
  Maximum Head Number // Integer (WORD)
  disk_specify_1 // Integer (BYTE)
  disk_specify_2 // Integer (BYTE)
  disk_motor_wait // Integer (BYTE)
  disk_sector_siz // Integer (BYTE)
  disk_eot // Integer (BYTE)
  disk_rw_gap // Integer (BYTE)
  disk_dtl // Integer (BYTE)
  disk_fmt_gap // Integer (BYTE)
  disk_fill // Integer (BYTE)
  disk_head_sttl // Integer (BYTE)
  disk_motor_strt // Integer (BYTE)
}
```

Table 9.7: ACPI Floppy Drive Information

Package Element	Element Object Type	Actual Valid Data Width
00 - Drive Number	Integer	BYTE
01 - Device Type	Integer	BYTE
02 - Maximum Cylinder Number	Integer	WORD
03 - Maximum Sector Number	Integer	WORD
04 - Maximum Head Number	Integer	WORD
05 - Disk_specify_1	Integer	BYTE
06 - Disk_specify_2	Integer	BYTE
07 - Disk_motor_wait	Integer	BYTE
08 - Disk_sector_siz	Integer	BYTE
09 - Disk_eot	Integer	BYTE
10 - Disk_rw_gap	Integer	BYTE
11 - Disk_dtl	Integer	BYTE
12 - Disk_fmt_gap	Integer	BYTE
13 - Disk_fill	Integer	BYTE
14 - Disk_head_sttl	Integer	BYTE
15 - Disk_motor_strt	Integer	BYTE

9.8.3 _FDM (Floppy Disk Drive Mode)

This control method switches the mode (300 RPM or 360 RPM) of all floppy disk drives attached to this controller. If this control method is implemented, the platform must reset the mode of all drives to 300RPM mode after a Dx to D0 transition of the controller.

Arguments:(1)

Arg0 - An Integer containing the new drive mode

0 - Set the mode of all drives to 300 RPM mode

1 - Set the mode of all drives to 360 RPM mode

Return Value:

None

9.9 GPE Block Device

The GPE Block device is an optional device that allows a system designer to describe GPE blocks beyond the two that are described in the FADT. Control methods associated with the GPE pins of GPE block devices exist as children of the GPE Block device, not within the _GPE namespace. Because GPE block devices are meant as an extension to the GPE blocks defined in the FADT, and that portion of the FADT is to be ignored in hardware-reduced ACPI, GPE block devices are not supported in hardware-reduced ACPI.

A GPE Block device consumes I/O or memory address space, as specified by its _PRS or _CRS child objects. The interrupt vector used by the GPE block does not need to be the same as the SCI_INT field. The interrupt used by the GPE block device is specified in the _CRS and _PRS methods associated with the GPE block. The _CRS of a GPE Block device may only specify a single register address range, either I/O or memory. This range contains two registers: the GPE status and enable registers. Each register's length is defined as half of the length of the _CRS-defined register address range.

A GPE Block device must have a _HID or a _CID of "ACPI0006."

Note: A system designer must describe the GPE block necessary to bootstrap the system in the FADT as a GPE0/GPE1 block. GPE Block devices cannot be used to implement these GPE inputs.*

A GPE Block Device must contain the _Lxx, _Exx, _Wxx, _CRS, _PRS, and _SRS methods required to use and program that block.

To represent the GPE block associated with the FADT, the system designer should include in the namespace a Device object with the ACPI0006 _HID that contains no _CRS, _PRS, _SRS, _Lxx, _Exx, or _Wxx methods. OSPM assumes that the first such ACPI0006 device is the GPE Block Device that is associated with the FADT GPEs. (See the example below).

```
// ASL example of a standard GPE block device

Device(\_SB.PCI0.GPE1) {
    Name(_HID, "ACPI0006")
    Name(_UID, 2)
    Name(_CRS, Buffer () {
        IO(Decode16, FC00, FC03, 4, 4,)
        IRQ( Level, ActiveHigh, Shared,) { 5 }
    })
}
```

(continues on next page)

(continued from previous page)

```

Method(_L02) { ... }
Method(_E07) { ... }
Method(_W04) { ... }
}

// ASL example of a GPE block device that refers to the FADT GPEs.
// Cannot contain any \_Lxx, \_Exx, \_Wxx, \_CRS, \_PRS, or. \_SRS methods.
Device(\_SB.PCI0.GPE0) {
    Name(_HID, "ACPI0006")
    Name(_UID, 1)
}

```

Notice that it is legal to replace the I/O descriptors with Memory descriptors if the register is memory mapped.

If the system must run any GPEs to bootstrap the system (for example, when Embedded Controller events are required), the associated block of GPEs must be described in the FADT. This register block is not relocatable and will always be available for the life of the operating system boot.

A GPE block associated with the ACPI0006 _HID can be stopped, ejected, reprogrammed, and so on. The system can also have multiple such GPE blocks.

9.9.1 Matching Control Methods for Events in a GPE Block Device

When a GPE Device raises an interrupt, OSPM executes a corresponding control method (see *Queuing the matching control method for execution*). These control methods for GPE Devices (of the form _Lxx, _Exx, and _Wxx) are not within the _GPE namespace. They are children of the GPE Block device.

For example:

```

Device(GPE5) {
    Name(_HID, "ACPI0006")
    Method(_L02) { ... }
    Method(_E07) { ... }
    Method(_W04) { ... }
}

```

9.10 Module Device

This optional device is a container object that acts as a bus node in a namespace. It may contain child objects that are devices or buses. The module device is declared using the ACPI0004 hardware identifier (HID).

If the module device contains a _CRS object, the bus described by this object is assumed to have these resources available for consumption by its child devices. If a _CRS object is present, any resources not produced in the module device's _CRS object may not be allocated to child devices.

Providing a _CRS object is undesirable in some module devices. For example, consider a module device used to describe an add-in board containing multiple host bridges without any shared resource decoding logic. In this case the resource ranges available to the host bridges are not controlled by any entity residing on the add-in board, implying that a _CRS object in the associated module device would not describe any real feature of the underlying hardware. A module device must contain a _CRS object if the device contains any PCI host bridge devices.

To account for cases like this, the system designer may optionally omit the module device's _CRS object. If no _CRS object is present, OSPM will assume that the module device is a simple container object that does not produce the

resources consumed by its child devices. In this case, OSPM will assign resources to the child devices as if they were direct children of the module device's parent object.

For an example with a module device `_CRS` object present, consider a Module Device containing three child memory devices. If the `_CRS` object for the Module Device contains memory from 2 GB through 6 GB, then the child memory devices may only be assigned addresses within this range.

Example:

```

Device (\_SB.NOD0) {
    Name (_HID, "ACPI0004")          // Module device
    Name (_UID, 0)
    Name (_PRS, ResourceTemplate() {
        WordIO (
            ResourceProducer,
            MinFixed,                // \_MIF
            MaxFixed,,,              // \_MAF
            0x0000,                  // \_GRA
            0x0000,                  // \_MIN
            0x7FFF,                  // \_MAX
            0x0,                     // \_TRA
            0x8000)                  // \_LEN
        DWordMemory (
            ResourceProducer,,       // For Main Memory + PCI
            MinNotFixed,             // _MIF
            MaxNotFixed,             // _MAF
            Cacheable,               // _MEM
            ReadWrite,               // _RW
            0x0FFFFFFFF,             // _GRA
            0x40000000,              // _MIN
            0x7FFFFFFFF,             // _MAX
            0x0,                     // _TRA
            0x00000000)              // _LEN
    })
    Method (_SRS, 1) { ... }
    Method (_CRS, 0) { ... }

    Device (MEM0) {                 // Main Memory (256MB module)
        Name (_HID, EISAID("PNP0C80"))
        Name (_UID, 0)
        Method (_STA, 0) {           // If memory not present --> Return(0x00),
                                    // Else if memory is disabled --> Return(0x0D),
                                    // Else --> Return(0x0F)
        }
        Name (_PRS, ResourceTemplate () {
            DWordMemory (,,,,
                Cacheable,          // _MEM
                ReadWrite,          // _RW
                0x0FFFFFFFF,         // _GRA
                0x40000000,         // _MIN
                0x7FFFFFFFF,         // _MAX
                0x0,                 // _TRA
                0x10000000)         // _LEN
            })
        Method (_CRS, 0) { ... }
        Method (_SRS, 1) { ... }
        Method (_DIS, 0) { ... }
    }
}

```

(continues on next page)

(continued from previous page)

```

Device (MEM1) {
    // Main Memory (512MB module)
    Name (_HID, EISAID("PNP0C80"))
    Name (_UID, 1)
    Method (_STA, 0) {
        // If memory not present --> Return(0x00)
        // Else if memory is disabled --> Return(0x0D)
        // Else --> Return(0x0F)
    }
    Name (_PRS, ResourceTemplate () {
        DWordMemory (,,,
            Cacheable, // _MEM
            ReadWrite, // _RW
            0x1FFFFFFF, // _GRA
            0x40000000, // _MIN
            0x7FFFFFFF, // _MAX
            0x0, // _TRA
            0x20000000) // _LEN
        })
        Method (_CRS, 0) { ... }
        Method (_SRS, 1) { ... }
        Method (_DIS, 0) { ... }
    }
Device (PCI0) { // PCI Root Bridge
    Name (_HID, EISAID("PNP0A03"))
    Name (_UID, 0)
    Name (_BBN, 0x00)
    Name (_PRS, ResourceTemplate () {
        WordBusNumber (
            ResourceProducer,
            MinFixed, // _MIF
            MaxFixed,, // _MAF
            0x00, // _GRA
            0x00, // _MIN
            0x7F, // _MAX
            0x0, // _TRA
            0x80) // _LEN
        WordIO (
            ResourceProducer,
            MinFixed, // _MIF
            MaxFixed,,, // _MAF
            0x0000, // _GRA
            0x0000, // _MIN
            0x0CF7, // _MAX
            0x0, // _TRA
            0x0CF8) // _LEN
        WordIO (
            ResourceProducer,
            MinFixed, // _MIF
            MaxFixed,,, // _MAF
            0x0000, // _GRA
            0x0D00, // _MIN
            0x7FFF, // _MAX
            0x0, // _TRA
            0x7300) // _LEN
        DWordMemory (
            ResourceProducer,,
            MinNotFixed, // _MIF

```

(continues on next page)

(continued from previous page)

```

        MaxNotFixed,    // _MAF
        NonCacheable,  // _MEM
        ReadWrite,     // _RW
        0xFFFFFFFF,    // _GRA
        0x40000000,    // _MIN
        0x7FFFFFFF,    // _MAX
        0x0,           // _TRA
        0x00000000)    // _LEN
    })
    Method (_CRS, 0) { ... }
    Method (_SRS, 1) { ... }
}
}

```

9.11 Memory Devices

Memory devices allow a platform to convey dynamic properties of memory to OSPM and are required when a platform supports the addition or removal of memory while the system is active or when the platform supports memory bandwidth monitoring and reporting (see [Section 9.11.2](#)). Memory devices may describe exactly the same physical memory that the System Address Map interfaces describe (see [Section 15](#)). They do not describe how that memory is, or has been, used. If a region of physical memory is marked in the System Address Map interface as `AddressRangeReserved` or `AddressRangeNVS` and it is also described in a memory device, then it is the responsibility of the OS to guarantee that the memory device is never disabled.

It is not necessary to describe all memory in the system with memory devices if there is some memory in the system that is static in nature. If, for instance, the memory that is used for the first 16 MB of system RAM cannot be ejected, inserted, or disabled, that memory may only be represented by the System Address Map interfaces. But if memory can be ejected, inserted, or disabled, or if the platform supports memory bandwidth monitoring and reporting, the memory must be represented by a memory device.

9.11.1 Address Decoding

Memory devices must provide a `_CRS` object that describes the physical address space that the memory decodes. If the memory can decode alternative ranges in physical address space, the devices may also provide `_PRS`, `_SRS` and `_DIS` objects. Other device objects may also apply if the device can be ejected.

9.11.2 Memory Bandwidth Monitoring and Reporting

During platform operation, an adverse condition external to the platform may arise whose remedy requires a reduction in the platform's available memory bandwidth. For example, a server management controller's detection of an adverse thermal condition or the need to reduce the total power consumption of platforms in the data center to stay within acceptable limits. Providing OSPM with knowledge of a platform induced reduction of memory bandwidth enables OSPM to provide more robust handling of the condition. The following sections describe objects OSPM uses to configure platform-based memory bandwidth monitoring and to ascertain available memory bandwidth when the platform performs memory bandwidth throttling.

9.11.2.1 **_MBM (Memory Bandwidth Monitoring Data)**

The optional **_MBM** object provides memory bandwidth monitoring information for the memory device.

Arguments:

None

Return Value:

A Package containing memory device status information as described in the *MBM Package Details* below.

Return Value Information:

_MBM evaluation returns a package of the following format:

```
Package () {
    Revision, // Integer
    WindowSize, // Integer DWORD
    SamplingInterval, // Integer DWORD
    MaximumBandwidth, // Integer DWORD
    AverageBandwidth, // Integer DWORD
    LowBandwidth, // Integer DWORD
    LowNotificationThreshold, // Integer DWORD
    HighNotificationThreshold // Integer DWORD
}
```

Table 9.8: **MBM Package Details**

Field	Format	Description
Revision	Integer	Current revision is: 0
Window Size	Integer (DWORD)	This field indicates the size of the averaging window (in seconds) that the platform uses to report average bandwidth.
Sampling Interval	Integer (DWORD)	This field indicates the sampling interval (in seconds) that the platform uses to record bandwidth during the averaging window.
Maximum Bandwidth	Integer (DWORD)	This field indicates the maximum memory bandwidth (in megabytes per second) for the memory described by this memory device.
Average Bandwidth	Integer (DWORD)	This field indicates the moving average memory bandwidth (in percent) for the averaging window.
Low Bandwidth	Integer (DWORD)	This field indicates the lowest memory bandwidth (in percent) recorded for the averaging window.
Low Notification Threshold	Integer (DWORD)	The platform to issues a Notify (0x80) on the memory device when the moving average memory bandwidth value (in percent) falls below the value indicated by this field.
High Notification Threshold	Integer (DWORD)	The platform to issues a Notify (0x81) on the memory device when the moving average memory bandwidth value (in percent) increases to or exceeds the value indicated by this field.

9.11.2.2 _MSM (Memory Set Monitoring)

This optional object sets the memory bandwidth monitoring parameters described in Section 9.11.2.1 above.

Arguments(4)

Arg0 - WindowSize (Integer(DWORD)): indicates the window size in seconds.

Arg1 - SamplingInterval (Integer(DWORD)): indicates the sampling interval in seconds.

Arg2 - LowNotificationThreshold (Integer(DWORD)): indicates the low notification threshold in percent. Must be <= HighNotificationThreshold.

Arg3 - HighNotificationThreshold (Integer(DWORD)): indicates the high notification threshold in percent. Must be >= LowNotificationThreshold.

Return Value

An Integer (DWORD) containing a bit encoded result code as follows:

0x00000000 - Succeeded to set all memory bandwidth monitoring parameters.

Non-Zero - At least one memory bandwidth monitoring parameter value could not be set as follows:

Table 9.9: MSM Result Encoding

Bits	Definition
0	If clear indicates WindowSize was set successfully. If set, indicates invalid WindowSize argument.
1	If clear indicates SamplingInterval was set successfully. If set, indicates invalid SamplingInterval argument.
2	If clear indicates LowNotificationThreshold was set successfully. If set, indicates invalid LowNotificationThreshold argument.
3	If clear indicates HighNotificationThreshold was set successfully. If set, indicates invalid HighNotificationThreshold argument.
31:4	Reserved (must be 0)

9.11.3 _OSC Definition for Memory Device

OSPM evaluates _OSC under the Memory Device to convey OSPM capabilities to the platform. Argument definitions are as follows

Arguments(4)

Arg0 - UUID (Buffer): 03B19910-F473-11DD-87AF-0800200C9A66

Arg1 - Revision ID (Integer): 1

Arg2 - Count of Entries in Arg3 (Integer): 2

Arg3 - DWORD capabilities (Buffer):

- First DWORD: Described in Section 6.2.10
- Second DWORD: See Section 6.4.3.5.2.

Return Value

A Buffer containing platform capabilities

Table 9.10: Memory Device _OSC Capabilities DWORD number 2

Bits	Field Name	Definition
0	Memory Bandwidth Change Notifications	This bit is set if OSPM supports the processing of memory bandwidth change notifications. If the platform supports the ability to issue a notification when Memory Bandwidth changes, it may only do so after _OSC has been evaluated with this bit set. _OSC evaluation with this bit clear will cause the platform to cease issuing notifications if previously enabled.
31:1		Reserved (must be 0)

Return Value Information

Capabilities Buffer (Buffer) - The platform acknowledges the Capabilities Buffer by returning a buffer of DWORDs of the same length. Set bits indicate acknowledgement and cleared bits indicate that the platform does not support the capability.

9.11.4 Example: Memory Device

```
Scope (\_SB){
    Device (MEM0) {
        Name (_HID, EISAID ("PNP0C80"))
        Name (_CRS, ResourceTemplate () {
            QWordMemory
                ResourceConsumer,
                ,
                MinFixed,
                MaxFixed,
                Cacheable,
                ReadWrite,
                0xFFFFFFFF,
                0x10000000,
                0x30000000,
                0,
                ,, )
        }
    }
}
```

9.12 _UPC (USB Port Capabilities)

This optional object is a method that allows the platform to communicate to the operating system, certain USB port capabilities that are not provided for through current USB host bus adaptor specifications (e.g. UHCI, OHCI and EHCI). If implemented by the platform, this object will be present for each USB port (child) on a given USB host bus adaptor; operating system software can examine these characteristics at boot time in order to gain knowledge about the system’s USB topology, available USB ports, etc. This method is applicable to USB root hub ports as well as ports that are implemented through integrated USB hubs.

Arguments

None

Return Value

A Package as described below

Return Value Information

```

Package {
    Connectable          // Integer (BYTE)
    Type                 // Integer (BYTE)
    Reserved0            // Integer
    Reserved1            // Integer
}
    
```

Table 9.11: UPC Return Package Values

Element	Object Type	Description
Connectable	Integer (BYTE)	If this value is non-zero, then the port is connectable. If this value is zero, then the port is not connectable.
Type	Integer (BYTE)	Specifies the host connector type. It is ignored by OSPM if the port is not user visible: 0x00: Type 'A' connector 0x01: Mini-AB connector 0x02: ExpressCard 0x03: USB 3 Standard-A connector 0x04: USB 3 Standard-B connector 0x05: USB 3 Micro-B connector 0x06: USB 3 Micro-AB connector 0x07: USB 3 Power-B connector 0x08: USB-C connector - USB2-only 0x09: USB-C connector - USB2 and SS with Switch 0x0A: USB-C connector - USB2 and SS without Switch 0x0B- 0xFE: <i>Reserved</i> 0xFF: Proprietary connector
USB-C Port Capabilities	Integer	Fields in this entry are valid only for a USB-C port (values 0x08, 0x09, or 0x0A) described by the the host connector Type (above): - Bits [1:0]: Retimer Count- number of retimer devices present on the board between the Host Router and this Port (connector) The maximum value is 2 (10b). If present, the retimer devices apply to USB4, USB 3, and any Alternate Modes supported. - Bit [2]: PCI Express Tunneling supported. This bit is valid only for ports that support USB4 or TBT3. If PCI Express Tunneling for USB4 is not supported via the USB4 _OSC mechanism, then the value of this bit is indeterminate. - Bit [3]: DisplayPort Alternative Mode (DP Alt Mode) supported. This bit is required to be set for ports that support USB4 or Thunderbolt™ 3. - Bit [4]: USB4 Supported. - Bit [5] Thunderbolt™ 3 Alternate Mode (TBT3) supported. All other bits Reserved and set to zero (0).
Reserved1	Integer	This value is reserved for future use and must be zero.

Additional Notes:

The definition of a connectable port is dependent on the implementation of the USB port within a particular platform. For example:

- If a USB port is user visible (as indicated by the `_PLD` object) and connectable, then an end user can freely connect and disconnect USB devices to the USB port.
- If a USB port is not user visible and is connectable, then an end user cannot freely connect and disconnect USB devices to the USB port. A USB device that is directly “hard-wired” to a USB port is an example of a USB port that is not user visible and is connectable.
- If a USB port is not user visible and is not connectable, then the USB port is physically implemented by the USB host controller, but is not being used by the platform and therefore cannot be accessed by an end user.

A USB port cannot be specified as both visible and not connectable.

The pins of a Type-C connector support one USB2 signal pair (D+/D-) and two SuperSpeed signal pairs (SSTXp1/SSTXn1 and SSRXp2/SSRXn2). The use of two SS signal pairs allows the CC wire and USB SuperSpeed data bus wires to be used for signaling within the cable track without regard to the orientation and twist of the cable.

Type C connector - USB2 USB2-only receptacles

These only implement the USB2 signal pair, and do not implement the SS signal pairs.

Type C connector - USB2 and SS with Switch receptacles

These implement the USB2 signal pair, and a Functional Switch with a physical Multiplexer that is used to dynamically connect one of the two receptacle SuperSpeed signal pairs to a single USB Host Controller port as function of the Type-C plug orientation.

Type C connector - USB2 and SS *without* Switch receptacles

These implement the USB2 signal pair and a Functional Switch by connecting each receptacle SuperSpeed signal pair to a separate USB Host Controller port.

Note: See the USB Type-C Specification at <https://www.usb.org/documents> for more information.

Example

The following is an example of a port characteristics object implemented for a USB host controller’s root hub where:

- Three Ports are implemented; Port 1 is not user visible/not connectable and Ports 2 and 3 are user visible and connectable.
- Port 2 is located on the back panel
- Port 3 has an integrated 2 port hub. Note that because this port hosts an integrated hub, it is therefore not shareable with another host controller (e.g. If the integrated hub is a USB2.0 hub, the port can never be shared with a USB1.1 companion controller).
- The ports available through the embedded hub are located on the front panel and are adjacent to one another.

```
//
// Root hub device for this host controller.
// This controller implements 3 root hub ports.
//
Device( RHUB) {
    Name( \_ADR, 0x00000000)           // Value of 0 is reserved for root HUB
    //
    // Root hub, port 1
    //
    Device( PRT1) {
        // Address object for port 1. This value must be 1.
        Name( \_ADR, 0x00000001)
        // USB port capabilities object. This object returns the system
```

(continues on next page)

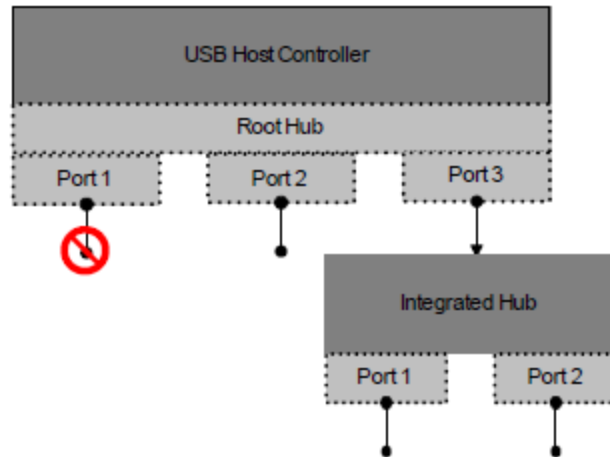

Fig. 9.4: USB ports

(continued from previous page)

```

// specific USB port configuration information for port number 1
// Because this port is not connectable it is assumed to be not visible.
// Therefore a \_PLD descriptor is not required.
Name( \_UPC, Package(){
    0x00, // Port is not connectable
    0xFF, // Connector type (N/A for non-visible ports)
    0x00000000, // Reserved 0 - must be zero
    0x00000000}) // Reserved 1 - must be zero
} // Device( PRT1)
//
// Root Hub, Port 2
//
Device( PRT2) {
    // Address object for port 2. This value must be 2
    Name(_ADR, 0x00000002)
    Name( \_UPC, Package(){
        0xFF, // Port is connectable
        0x00, // Connector type - Type 'A'
        0x00000000, // Reserved 0 - must be zero
        0x00000000}) // Reserved 1 - must be zero
    // provide physical port location info
    Name( \_PLD, Package(1) {
        Buffer(0x14) {
            0x82,0x00,0x00,0x00, // Revision 2, Ignore color
            // Color (ignored), width and height not
            0x00,0x00,0x00,0x00, // required as this is a standard USB 'A' type
            // connector
            0x69,0x0c,0x00,0x00, // User visible, Back panel, Vertical
            // Center, shape = vert. rectangle
            0x03,0x00,0x00,0x00, // ejectable, requires OPSPM eject assistance
            0xFF,0xFF,0xFF,0xFF}) // Vert. and Horiz. Offsets not supplied
    } // Device( PRT2)
//
// Root Hub, Port 3
//
Device( PRT3) { // This device is the integrated USB hub.

```

(continues on next page)

(continued from previous page)

```

// Address object for port 3. This value must be 3
Name(_ADR, 0x00000003)
// Because this port is not connectable it is assumed to be not visible.
// Therefore a \_PLD descriptor is not required.
Name( \_UPC, Package(){
    0xFF, // Port is connectable
    0xFF, // Connector type (N/A for non-visible ports)
    0x00000000, // Reserved 0 - must be zero
    0x00000000}) // Reserved 1 - must be zero
//
// Integrated hub, port 1
//
Device( PRT1) {
// Address object for the port. Because the port is implemented on
// integrated hub port #1, this value must be 1
Name( \_ADR, 0x00000001)
// USB port characteristics object. This object returns the system
// specific USB port configuration information for integrated hub port
// number 1
Name( \_UPC, Package(){
    0xFF, // Port is connectable
    0x00, // Connector type - Type 'A'
    0x00000000, // Reserved 0 - must be zero
    0x00000000}) // Reserved 1 - must be zero
// provide physical port location info
Name( \_PLD, Package(1) {
    Buffer(0x14) {
        0x82,0x00,0x00,0x00,, // Revision 2, Ignore color
// Color (ignored), width and height not
        0x00,0x00,0x00,0x00, // required as this is a standard USB 'A' type
// connector
        0xa1,0x10,0x00,0x00, // User visible, front panel, Vertical
// lower, horz. Left, shape = horz. rectangle
        0x03,0x00,0x00,0x00, // ejectable, requires OPSPM eject assistance
        0xFF,0xFF,0xFF,0xFF}) // Vert. and Horiz. Offsets not supplied
    } // Device( PRT1)
//
// Integrated hub, port 2
//
Device( PRT2) { // Address object for the port. Because the port
// is implemented on integrated hub port #2,
// this value must be 2
    Name( \_ADR, 0x00000002) // USB port characteristics object. This object
// returns the system-specific USB port_
↪configuration // information for integrated hub port number 2
    Name( \_UPC, Package(){
        0xFF, // Port is connectable
        0x00, // Connector type - Type 'A'
        0x00000000, // Reserved 0 - must be zero
        0x00000000}) // Reserved 1 - must be zero
    Name( \_PLD, Package(1) {
        Buffer(0x14) {
            0x82,0x00,0x00,0x00, // Revision 2, Ignore color
// Color (ignored), width and height not
            0x00,0x00,0x00,0x00, // required as this is a standard USB 'A' type

```

(continues on next page)

(continued from previous page)

```

                                // connector
0xa1,0x12,0x00,0x00, // User visible, front panel, Vertical
                                // lower, horz. right, shape = horz. rectangle
0x03,0x00,0x00,0x00, // ejectable, requires OPM eject assistance
0xFF,0xFF,0xFF,0xFF) // Vert. and Horiz. Offsets not supplied
    }                                // Device( PRT2)
  }                                // Device( PRT3)
}                                  // Device( RHUB)

```

9.12.1 USB 2.0 Host Controllers and _UPC and _PLD

Platforms implementing USB2.0 host controllers that consist of one or more USB1.1 compliant companion controllers (e.g. UHCI or OHCI) must implement a _UPC and a _PLD object for each port USB port that can be routed between the EHCI host controller and its associated companion controller. This is required because a USB Port Capabilities object implemented for a port that is a child of an EHCI host controller may not be available if the OPM disables the parent host controller. For example, if root port 1 on an EHCI host controller is routable to root port 1 on its companion controller, then the namespace must provide a _UPC and a _PLD object under each host controller's associated port 1 child object.

Example

```

Scope(\_SB) {
  ...
  Device(PCI0) {
    ...
                                // Host controller (EHCI)
  Device( USB0) {
                                // PCI device#/Function# for this HC. Encoded as specified in_
↳the ACPI
                                // specification
  Name(_ADR, 0xyyyyyzzzz)
                                // Root hub device for this HC #1.
  Device(RHUB) {
  Name(_ADR, 0x00000000) // must be zero for USB root hub
                                // Root hub, port 1
  Device(PRT1) {
  Name(_ADR, 0x00000001)
                                // USB port configuration object. This object returns the system
                                // specific USB port configuration information for port number 1
                                // Must match the \_UPC declaration for USB1.RHUB.PRT1 as it is_
↳this
                                // host controller's companion
  Name( \_UPC, Package(){
    0xFF, // Port is connectable
    0x00, // Connector type - Type 'A'
    0x00000000, // Reserved 0 - must be zero
    0x00000000} // Reserved 1 - must be zero

                                // provide physical port location info for port 1
                                // Must match the \_UPC declaration for USB1.RHUB.PRT1 as it is_
↳this
                                // host controller's companion
    Name( \_PLD, Package(1) {
      Buffer(0x14) {

```

(continues on next page)

(continued from previous page)

```

0x82,0x00,0x00,0x00, // Revision 2, Ignore color
                      // Color (ignored), width and height not
0x00,0x00,0x00,0x00, // required as this is a standard USB 'A'
                      // type connector

0xa1,0x10,0x00,0x00, // User visible, front panel, Vertical
                      // lower, horz. Left, shape = horz. Rect.
0x03,0x00,0x00,0x00, // ejectable, needs OPSM eject assistance
                      0xFF,0xFF,0xFF,0xFF}} // Vert. and Horiz. Offsets not supplied
}
// Device( PRT1)
//
// Define other ports, control methods, etc
...
...
} // Device( RHUB)
} // Device( USB0)

// Companion Host controller (OHCI or UHCI)
Device( USB1) {
// PCI device#/Function# for this HC. Encoded as specified in
→the ACPI
// specification
Name(_ADR, 0xyyyzzzz)
// Root hub device for this HC #1.
Device(RHUB) {
Name(_ADR, 0x00000000) // must be zero for USB root hub
// Root hub, port 1
Device(PRT1) {
Name(_ADR, 0x00000001)
// USB port configuration object. This object returns the system
// specific USB port configuration information for port number 1
// Must match the \_UPC declaration for USB0.RHUB.PRT1 as this
→host
// controller is a companion to the EHCI host controller
// provide physical port location info for port 1
Name( \_UPC, Package(){
0xFF, // Port is connectable
0x00, // Connector type - Type 'A'
0x00000000, // Reserved 0 - must be zero
0x00000000}) // Reserved 1 - must be zero

// Must match the \_PLD declaration for USB0.RHUB.PRT1 as this
→host
// controller is a companion to the EHCI host controller
Name( \_PLD, Package(1) {
Buffer( 0x14) {
0x82,0x00,0x00,0x00, // Revision 2, Ignore color
// Color (ignored), width and height not
0x00,0x00,0x00,0x00, // required as this is a standard USB 'A'
// type connector

0xa1,0x10,0x00,0x00, // User visible, front panel, Vertical
// lower, horz. Left, shape = horz. Rect.
0x03,0x00,0x00,0x00, // ejectable, requires OPSM eject assistance
0xFF,0xFF,0xFF,0xFF}} // Vert. and Horiz. Offsets not supplied
} // Device( PRT1)

```

(continues on next page)

(continued from previous page)

```

        //
        // Define other ports, control methods, etc
...
...
}          // Device( RHUB)
}          // Device( USB1)
}          // Device( PCI0)
}          // Scope( \_SB)

```

9.12.2 SuperSpeed USB Port and Connector Mapping

This also applies to USB 3.x host controllers. They may have USB 2.0 companion controllers with the switching capability and without, or Low/Full/High-speed ports in conjunction with SuperSpeed ports on the same Root Hub. Each USB port implementing `_UPC` and a `_PLD` as a child of the xHCI controller will indicate to OSPM which Super Speed USB and ports are electrically connected to the same connector as Low/Full/High-Speed USB ports on the same or other controllers.

9.12.3 USB4 Port and USB-C Connector Mapping

USB-C connectors support multiple electrical protocols, including SuperSpeed USB, DisplayPort Alternative Mode, Thunderbolt™ 3, and USB4. The `_PLD` objects within the port Device scope for each connected controller port (e.g. SS USB, DP, PCIe) that are routed to the same USB connector must return the same value, even if no connector is user-accessible. USB4 tunnels other protocols based on the USB4 specification: SS USB and DP are required; PCI Express is optional. The `_UPC` object describes to OSPM whether PCIe is tunneled on that port or not.

```

Scope (\_SB)
{
    Device (PLDS)      // Device container for board-specific _PLD objects
    {
        Name (_HID, EISAID ("PNP0A05") )
        Name (_UID, "_PLD Object Container")

        Name(PLD0, Package () { // USB-C Connector, Left Panel
            ToPLD(
                PLD_Revision = 2,
                PLD_IgnoreColor = 1,
                PLD_Width = 8,
                PLD_Height = 3,
                PLD_UserVisible = 1,
                PLD_Panel = "LEFT",
                PLD_HorizontalPosition = "CENTER",
                PLD_VerticalPosition = "CENTER",
                PLD_Shape = "OVAL",
                PLD_Ejectable = 1,
                PLD_EjectRequired = 1
            )
        })

        Name(PLD1, Package () { // USB-C Connector, Right Panel
            ToPLD(
                PLD_Revision = 2,
                PLD_IgnoreColor = 1,
                PLD_Width = 8,

```

(continues on next page)

(continued from previous page)

```

        PLD_Height = 3,
        PLD_UserVisible = 1,
        PLD_Panel = "RIGHT",
        PLD_HorizontalPosition = "CENTER",
        PLD_VerticalPosition = "CENTER",
        PLD_Shape = "OVAL",
        PLD_Ejectable = 1,
        PLD_EjectRequired = 1
    )
})

Name (PLDP, Package () { // Mini DisplayPort connector, Right Panel
    ToPLD(
        PLD_Revision = 2,
        PLD_IgnoreColor = 1,
        PLD_Width = 8,
        PLD_Height = 5,
        PLD_UserVisible = 1,
        PLD_Panel = "RIGHT",
        PLD_HorizontalPosition = "RIGHT",
        PLD_VerticalPosition = "CENTER",
        PLD_Shape = "HORIZONTALTRAPEZOID",
        PLD_Ejectable = 1,

    )
}) // End PLDP
} // End PLDS

Device (UPCS) // Device container for board-specific _UPC objects
{
    Name (_HID, EISAID ("PNP0A05") )
    Name (_UID, "_UPC Object Container")

    Name (UPC0, Package () { // Left USB-C connector properties
        1, // Connectable
        9, // USB-C, USB 2 and SS, no switch
        0x0D, // Retimers: 1; PCIe Tunneling, DP AltMode, USB4
        0 // Reserved
    })

    Name (UPC1, Package () { // Right USB-C connector properties
        1, // Connectable
        9, // USB-C, USB 2 and SS, no switch
        0x0C, // Retimers: 0; PCIe Tunneling, DP AltMode, USB4
        0 // Reserved
    })
} // End UPCS
}

```

```

Scope(\_SB.HB0) // PCI Express Host Bus
{
    Device (XHC0) // XHCI controller 0
    {
        Name (_ADR, 0x00030000) // Dev3, Fn0

        Device (RHUB) // USB Root Hub
    }
}

```

(continues on next page)

(continued from previous page)

```

{
    Name (_ADR, 0)
    Device (PRT1)    // Port 1 on Root Hub, Low/Full/High Speed
    {
        Name (_ADR, 1)
        Method (_PLD, 0) { Return (\_SB.PLDS.PLD0) } // Left USB-C Connector
        Method (_UPC, 0) { Return (\_SB.UPCS.UPC0) } // USB Capabilities
    }
    Device (PRT2)    // Port 2 on Root Hub, Low/Full/High Speed
    {
        Name (_ADR, 2)
        Method (_PLD, 0) { Return (\_SB.PLDS.PLD1) } // Right USB-C Connector
        Method (_UPC, 0) { Return (\_SB.UPCS.UPC1) } // USB Capabilities
    }
    Device (PRT3)    // Port 3 on Root Hub, SuperSpeed
    {
        Name (_ADR, 3)
        Method (_PLD, 0) { Return (\_SB.PLDS.PLD0) } // Left USB-C Connector
        Method (_UPC, 0) { Return (\_SB.UPCS.UPC0) } // USB Capabilities
    }
    Device (PRT4)    // Port 4 on Root Hub, SuperSpeed
    {
        Name (_ADR, 4)
        Method (_PLD, 0) { Return (\_SB.PLDS.PLD1) } // Right USB-C Connector
        Method (_UPC, 0) { Return (\_SB.UPCS.UPC1) } // USB Capabilities
    }
    Device (PRT5)    // Port 5 on Root Hub, SuperSpeed Tunneled over USB4
    {
        Name (_ADR, 5)
        Method (_PLD, 0) { Return (\_SB.PLDS.PLD0) } // Left USB-C Connector
        Method (_UPC, 0) { Return (\_SB.UPCS.UPC0) } // USB Capabilities
    }
    Device (PRT6)    // Port 2 on Root Hub, SuperSpeed Tunneled over USB4
    {
        Name (_ADR, 6)
        Method (_PLD, 0) { Return (\_SB.PLDS.PLD1) } // Right USB-C Connector
        Method (_UPC, 0) { Return (\_SB.UPCS.UPC1) } // USB Capabilities
    }
}

}

Device (PRP0)    // PCI Express Root Port 0
{
    Name (_ADR, 0x00050000) // Dev5, Fn0

    // Describe routing to Left USB-C connector, USB4 Tunneling
    Method (_PLD){ Return (\_SB.PLDS.PLD0) }
}

Device (PRP1)    // PCI Express Root Port 1
{
    Name (_ADR, 0x00050001) // Dev5, Fn1

    // Describe routing to Right USB-C connector, USB4 Tunneling
    Method (_PLD, 0) { Return (\_SB.PLDS.PLD1) }
}

```

(continues on next page)

(continued from previous page)

```

Device(GFX)      // Graphics Controller
{
    Name(_ADR, 0x00080000) // Dev8, Fn0
    // ...
    Device(DPR)      // Mini DisplayPort Right Connector
    {
        Name(_ADR, 0)
        Method (_PLD, 0) { Return (\_SB.PLDS.PLDP) }
    }
    Device(UCAL)     // USB-C DP AltMode Left
    {
        Name(_ADR, 1)
        Method (_PLD, 0) { Return (\_SB.PLDS.PLD0) }
    }
    Device(UCAR)     // USB-C DP AltMode Right
    {
        Name(_ADR, 2)
        Method (_PLD, 0) { Return (\_SB.PLDS.PLD1) }
    }
    Device(UCNL)     // USB-C Native USB4 Left
    {
        Name(_ADR, 3)
        Method (_PLD, 0) { Return (\_SB.PLDS.PLD0) }
    }
    Device(UCNR)     // USB-C Native USB4 Right
    {
        Name(_ADR, 4)
        Method (_PLD, 0) { Return (\_SB.PLDS.PLD1) }
    }
}

Device(PDC0) // USB-C PD Controller (UCSI 0)
{
    Name(_HID, EISAID ("PNPOCA0") )
    Name(_UID, 0)
    Method (_PLD, 0) { Return (\_SB.PLDS.PLD0) } // Left USB-C connector
}

Device(PDC1) // USB-C PD Controller (UCSI 1)
{
    Name(_HID, EISAID ("PNPOCA0") )
    Name(_UID, 1)
    Method (_PLD, 0) { Return (\_SB.PLDS.PLD1) } // Right USB-C connector
}
}

```

9.13 _PDO (USB Power Data Object)

Location:

This object is provided within the scope of a Device representing a USB-C connector.

Arguments:

None

Return Value:

A Package as follows:

```
Package {
    Revision,          // Integer (WORD)
    Flags,            // Integer (DWORD)
    SourcePDOList,    // Package
    SinkPDOList       // Package
}
```

The Revision field describes the revision of the USB PD Specification upon which the `_`
`↪``PDOList` entries are defined.

The Revision field is encoded as an integer, where the MSB is the major version, and `_`
`↪`the LSB is the minor version.

For example, the PD 3.1 specification is represented as the value 0x0301.

The Flags integer is encoded as follows:

Bits [2:0]: Preferred Power Role:

000b: Power Source Only

001b: Power Sink Only

010b: Dual Role Power - with a preference to be a Source

011b: Dual Role Power - with a preference to be a Sink

100b: Dual Role Power with no Source/Sink preference

101b-111b: Reserved

Bit[3]: PPS Supported:

If set, this USB-C connector supports Programable Power Supply (PPS) as specified `_`
`↪`in the USB PD Specification.

All other bits: Reserved, and must be 0.

The SourcePDOList and SinkPDOList are defined as follows:

```
Package {
    PDO[0],          // Integer (DWORD)
    ...
    PDO[N]          // Integer (DWORD)
}
```

If the USB-C connector does not support either Source or Sink power role, the corresponding SourcePDOList or SinkPDOList may be omitted. However, if `_PDO` is implemented, it's required to have at least one entry in either of them. Each entry in the list of PDOs is a 32-bit Integer. The encoding for these entries is defined in the USB Power Delivery Specification.

Here is a sample:

```
Device(UCM0) {USB Connector Manager device
    Device(CON0) // USB-C connector 0 {
        ...
```

(continues on next page)

(continued from previous page)

```

...
Name(_PDO, Package() {
    0x0301,          // USB PD Spec Revision
    0x0000000A,     // 0011b- PPS Not Supported, Dual Role Power, Prefers to be a
↳Sink
    Package() {    // SourcePDOList
        0x2C2F012C // Fixed Supply Source PDO
    },
    Package() {    // SinkPDOList
        0x3503C12C // Fixed Supply Sink PDO
    }
})
}
}

```

9.14 PC/AT RTC/CMOS Devices

Most computers contain an RTC device which also contains battery-backed RAM represented as a linear array of bytes. There is a standard mechanism for accessing the first 64 bytes of non-volatile RAM in devices that are compatible with the Motorola RTC/CMOS device that was in the IBM PC/AT. Newer devices usually contain at least 128 bytes of battery-backed RAM. New PNP IDs were assigned for these devices.

Certain bytes within the battery-backed RAM have pre-defined values. In particular, the time, date, month, year, century, alarm time and RTC periodic interrupt are read-only.

9.14.1 PC/AT-compatible RTC/CMOS Devices (PNP0B00)

The standard PC/AT-compatible RTC/CMOS device is denoted by the PnP ID PNP0B00. If an ACPI platform uses a device that is compatible with this device, it may describe this in its ACPI namespace. ASL may then read and write this as a linear 64-byte array. If PNP0B00 is used, ASL and ACPI operating systems may not assume that any extensions to the CMOS exist.

Note: This means that the CENTURY field in the *Fixed ACPI Description Table* may only contain values between 0 and 63.

Example:

The following is an example of how this device could be described:

```

Device (RTC0) {
    Name(_HID, EISAID("PNP0B00"))
    Name(_FIX, Package(1) { EISAID("PNP0B00") } )
    Name(_CRS, ResourceTemplate() {
        IO(Decode16, 0x70, 0x70, 0x1, 0x2)
    })

    OperationRegion(CMS1, SystemCMOS, 0, 0x40)

    Field(CMS1, ByteAcc, NoLock, Preserve) {
        CM00, 8,
        , 256,
    }
}

```

(continues on next page)

(continued from previous page)

```

    CM01, 8,
    CM02, 16,
    , 216,
    CM03, 8
  }
}

```

9.14.2 Intel PIIX4-compatible RTC/CMOS Devices (PNP0B01)

The Intel PIIX4 contains an RTC/CMOS device that is compatible with the one in the PC/AT. But it contains 256 bytes of non-volatile RAM. The first 64 bytes are accessed via the same mechanism as the 64 bytes in the PC/AT. The upper 192 bytes are accessed through an interface that is only used on Intel chips. (See the [Intel® 82371AB PIIX4 specification](#) for details.)

Any platform containing this device or one that is compatible with it may use the PNP ID PNP0B01. This will allow an ACPI-compatible OS to recognize the RTC/CMOS device as using the programming interface of the PIIX4. Thus, the array of bytes that ASL can read and write with this device is 256 bytes long.

Note: This also means that the CENTURY field in the *Fixed ACPI Description Table* may contain values between 0 and 255.

Example:

This is an example of how this device could be described:

```

Device (RTC0) {
    Name(_HID, EISAID("PNP0B01"))

    Name (_FIX, Package(1) {
        EISAID("PNP0B01")
    })

    Name(_CRS, ResourceTemplate() {
        IO(Decode16, 0x70, 0x70, 0x1, 0x2)
        IO(Decode16, 0x72, 0x72, 0x1, 0x2)
    })
    OperationRegion(CMS1, SystemCMOS, 0, 0x100)

    Field(CMS1, ByteAcc, NoLock, Preserve) {
        AccessAs(ByteAcc, 0),
        CM00, 8,
        , 256,
        CM01, 8,
        CM02, 16,
        , 224,
        CM03, 8,
        , 184,
        CENT, 8
    }
}

```

9.14.3 Dallas Semiconductor-compatible RTC/CMOS Devices (PNP0B02)

Dallas Semiconductor RTC/CMOS devices are compatible with the one in the PC/AT, but they contain 256 bytes of non-volatile RAM or more. The first 64 bytes are accessed via the same mechanism as the 64 bytes in the PC/AT. The upper bytes are accessed through an interface that is only used on Dallas Semiconductor chips.

Any platform containing this device or one that is compatible with it may use the PNP ID PNP0B02. This will allow an ACPI-compatible OS to recognize the RTC/CMOS device as using the Dallas Semiconductor programming interface. Thus, the array of bytes that ASL can read and write with this device is 256 bytes long.

Description of these devices is similar to the PIIX4 example above, and the CENTURY field of the FADT may also contain values between 0 and 255.

9.15 User Presence Detection Device

The following section illustrates the operation and definition of the control method-based User Presence Detection (UPD) device.

The user presence detection device can optionally support power management objects (e.g. _PS0, _PS3) to allow the OS to manage the device's power consumption.

The Plug and Play ID of an ACPI control method user presence detection device is ACPI000F.

Table 9.12: User Presence Detection Device

Object	Description
_UPD	The current user presence detection reading. [Required]
_UPP	User presence detection polling frequency in tenths of seconds. [Optional]

9.15.1 _UPD (User Presence Detect)

This control method returns the user presence detection reading, indicating whether or not the user is currently present from the perspective of this sensor. Three states are currently defined for UPD sensor readings: absent, present, and unknown, represented by the values 0x00, 0x01, and 0xFF respectively. The unknown state is used to convey that the sensor is currently unable to determine user presence due to some environmental or other transient factor. All other values are reserved.

Arguments:

None

Return Value:

An Integer containing the user presence code:

0x00 - Absent: A user is not currently detected by this sensor.

0x01 - Present: A user is currently detected by this sensor.

0xFF - Unknown: The sensor is currently unable to determine if a user is present or absent.

9.15.2 _UPP (User Presence Polling)

This optional object evaluates to a recommended polling frequency (in tenths of seconds) for this user presence sensor. A value of zero - or the absence of this object when other UPD objects are defined - indicates that the OS does not need to poll the sensor in order to detect meaningful changes in user presence (the hardware is capable of generating asynchronous notifications).

Arguments:

None

Return Value:

An Integer containing the recommended polling frequency in tenths of seconds. A value of zero indicates that polling is not required.

The use of polling is allowed but strongly discouraged by this specification. OEMs should design systems that asynchronously notify OSPM whenever a meaningful change in user presence occurs—relieving the OS of the overhead associated with polling.

This value is specified as tenths of seconds. For example, a value of 10 would be used to indicate a 1 second polling frequency. As this is a recommended value, OSPM will consider other factors when determining the actual polling frequency to use.

9.15.3 User Presence Sensor Events

To communicate changes in user presence to OSPM, AML code should issue a `Notify(upd_device, 0x80)` whenever a change in user presence has occurred. The OS receives this notification and calls the `_UPD` control method to determine the current user presence status.

UPD notifications should be generated whenever a transition occurs between one of the user presence states (absent, present, or unknown) - but at a level of granularity that provides an appropriate response without overly taxing the system with unnecessary interrupts.

9.16 I/O APIC Device

This optional device describes a discrete I/O APIC device that is not bus enumerated (e.g., as a PCI device). Describing such a device in the ACPI namespace is only necessary if hot plug of this device is supported. If hot plug of this device is not supported, an MADT I/O APIC entry is sufficient to describe this device.

An I/O APIC device is an I/O unit that complies with either of the APIC interrupt models supported by ACPI. These interrupt models are described in [Section 5.2.12.3](#) and [Section 5.2.12.9](#).

If the device is an I/O unit that complies with the APIC interrupt model, it is declared using the `ACPI000A` identifier. If this device is an I/O unit that complies with the SAPIC interrupt model, it is declared using the `ACPI000B` identifier. If this device complies with both the APIC and SAPIC interrupt models (`I/OxAPIC`), it is declared using the `ACPI0009` identifier.

An I/O APIC device declared using any of the above identifiers must contain a `_GSB` object to report its *`_GSB` (Global System Interrupt Base)*. It must also contain a `_CRS` object that reports the base address of the I/O APIC device. The `_CRS` object is required to contain only one resource, a memory resource pointing to the I/O APIC register base.

Note: Because the `_CRS` and `_GSB` methods provide sufficient information, it is not necessary to provide `_MAT` under an I/O APIC device.

For an I/O APIC device that is described both in the MADT and in the namespace, the base address described in the MADT entry must be the same as the base address in the IO APIC device `_CRS` at boot time. OSPM must use the information from the MADT until such a time as the `_CRS` and `_GSB` methods in the namespace device can be processed. At this point OSPM must ignore the MADT entry.

9.17 Time and Alarm Device

The following sections define the operation and definition of the optional control method-based Time and Alarm device, which provides a hardware independent abstraction and a more robust alternative to the Real Time Clock (RTC) (See *PC/AT RTC/CMOS Devices*.)

The time capabilities of the time and alarm device maintain the time of day information across platform power transitions, and keep track of time even when the platform is turned off. It is expected that the time on the platform will be consistent when different firmware interfaces are used to query the platform time. For example, a UEFI call to get the time should return the same time as if the OSPM used the time and alarm device at the same point in time.

The Time and Alarm device can optionally support power management objects (e.g. `_PS0`, `_PS3`) to allow the OS to manage the device’s power consumption.

The Time and Alarm device must support control method `_PRW` for being enabled to wake up the system. It might support `_DSW` or `_PSW` to provide the functionality to enable or disable the device’s ability to wake a sleep system. On Hardware-reduced ACPI platforms, `_PRW` is only required if the device depends on ACPI-defined power resources. `_PRW`’s *GPEInfo* structure is ignored by OSPM. For enabling Wakeup, `_DSW` and `_SxW` are used, and the wakeup event is signaled by the GPIO-signaled ACPI event mechanism (see Section 5.6.5).

The Plug and Play ID of the Time and Wake Alarm device is `ACPI000E`.

Table 9.13: Time and Alarm Device

Object	Description
<code>_GCP</code>	Get the capabilities of the time and alarm device
<code>_GRT</code>	Get the Real time
<code>_SRT</code>	Set the Real time
<code>_GWS</code>	Get Wake status
<code>_CWS</code>	Clear Wake Status
<code>_STP</code>	Sets expired timer wake policy for the specified timer.
<code>_STV</code>	Sets the value in the specified timer.
<code>_TIP</code>	Returns the current expired timer policy setting of the specified timer.
<code>_TIV</code>	Returns the remaining time of the specified timer.

9.17.1 Overview

The Time and Alarm device provides an alternative to the real time clock (RTC), which is defined as a fixed feature hardware device. The wake timers allow the system to transition from the S3 (or optionally S4/S5) state to S0 state after a time period elapses. In comparison with the Real Time Clock (RTC) Alarm, the Time and Alarm device provides a larger scale of flexibility in the operation of the wake timers, and allows the implementation of the time source to be abstracted from the OSPM.

Time and Alarm device provides the OSPM with a firmware abstraction of time and alarm services that can be applicable to a variety of hardware designs. The methods for setting and getting real time provide an alternative to the (RTC).

Time and Alarm devices that implement AC/DC wake service contain two programmable timers that can be configured to wake the system depending on the platform’s current power source (AC or DC) when the timers expire. The

two timers, which are referred to as the AC timer and the DC timer, are independent in that they are individually programmable and applicable without interfering each other. Each of the timers can be programmed with the number of seconds to elapse from the time the timer is programmed until a wake is requested. When a timer expires, the Time and Alarm device decides whether to wake the system based on the current power source. If the current power source is consistent with the timer type that expired, a wake signal will be asserted. Otherwise, the wake signal will not be asserted.

Time and Alarm devices that implement the AC only (power independent) wake contain one programmable timer that can be configured to wake up the system regardless of the platform's power source when the timer expires. To simplify the programming interface the AC wake will use the AC timer portion of the AC/DC wake; writes to the DC timer when AC only wake is supported will be ignored.

To simplify the programming interface for the time and alarm device, timer expiration events will persist. This means that if the OSPM programs a wake timer that expires before the OSPM completes the transition into S3 (or S4/S5 if supported) the time and alarm device will wake the system immediately after the OSPM completes the transition. Fig. 9.6 illustrates this behavior.

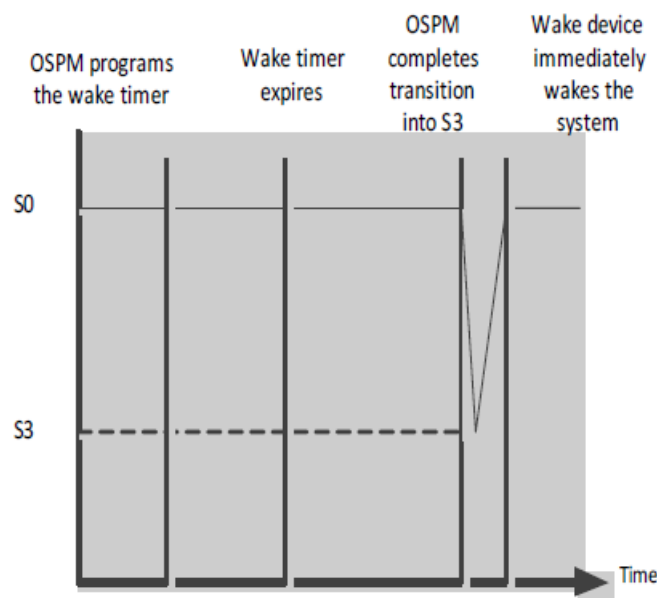

Fig. 9.5: Persistence of expired timer events

The time and alarm device will provide the OSPM with an interface to query the status of the wake timers and discover what timers have expired. This interface enables the OSPM to discover the wake source. The status of wake timers can be reset by setting the wake alarm; the OSPM may clear the alarm status using the clear wake status method. All expired wake timer must be cleared if the OSPM requires the platform to stay in S3 (S4/S5), otherwise the expired timers will immediately wake up the system.

For the AC/DC wake services, and in case the current power source is inconsistent with the timer type that expires, an expired timer wake policy value, in units of seconds, is defined that enables the time and alarm device to wake the system when the power source corresponding to the expired timer becomes active (wake either immediately, after some time period, or never). The expired timer wake policy is applicable only on devices that support AC/DC wake and only when the timer expires and the power source is not consistent with the timer type. The expired timer policy is applied in conjunction with expired timer persistence described earlier.

For example, if a mobile platform programs the AC timer to be 2 hours long and DC timer to be 4 hours long and then transitions from the S0 state to S3 state at 1:00 AM, the AC timer is set to expire at 3:00 AM and the DC timer is set to expire at 5:00 AM. For the AC Timer, a expired timer wake policy value is programmed as 60 seconds.

If the platform is unplugged from AC power at 1:40 AM and remains unplugged, the Time and Alarm Device will not wake up the system at 3:00 AM. If the platform remains on DC power until 5:00 AM when the DC timer expires, a wake signal will then be asserted. The following graph illustrates the above example.

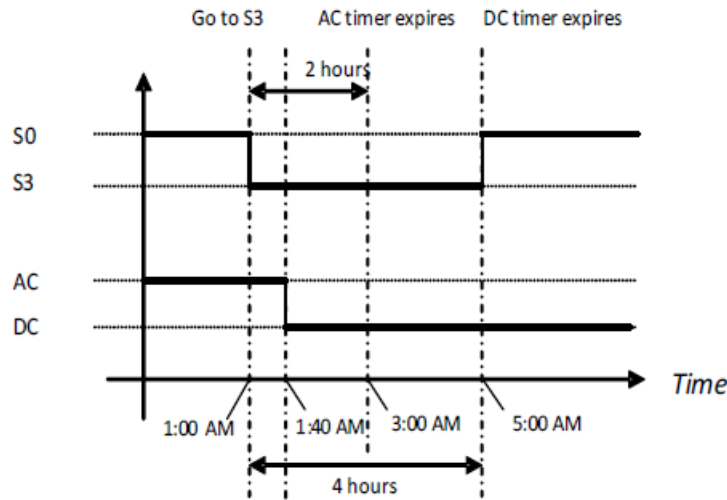

Fig. 9.6: System transitions with WakeAlarm — Timer

If the AC power is plugged in again at 4:00 AM, then the system will be woken up at 4:01 AM due to the AC expired timer wake policy value setting. The following graph illustrates this.

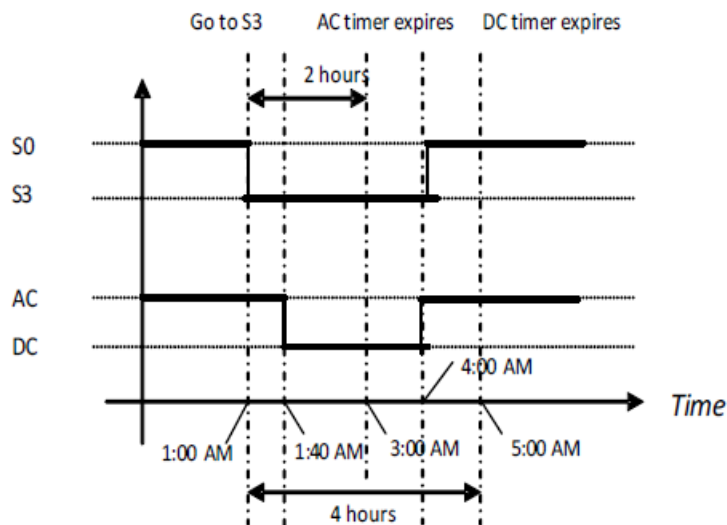

Fig. 9.7: System transitions with WakeAlarm — Policy

The Time and Alarm device can support a range of services, the OSPM evaluates the `_GCP` object to get the supported capabilities of the device. If the capabilities indicate that the device supports time services, the OSPM evaluates the `_GRT` and `_SRT` objects to get and set time respectively.

If alarm services are supported by the device, the OSPM evaluates the `_STV` object to program both the AC and DC timer values. The values, which are in units of seconds, indicate the elapsed time before the timer expires. OSPM evaluates the `_TIV` object to read the current AC and DC timer values (seconds remaining until expiration).

OSPM evaluates the `_STP` object to set timer policies for both the AC and DC timers OSPM reads the current timer

policy by evaluating the `_TIP` object, which return policy settings for both the AC and DC timer.

The OSPM evaluates the `_GWS` object to identify expired timers that may have waked the platform. The OSPM must evaluate the `_CWS` object to clear any expired timer events that can prevent the system from performing a sleep transition according the expired timer wake policy, and the expired timer persistence described above.

The Time and Alarm device, if implemented with wake support, must support waking up the system from S3. Waking from S4/S5 support is optional.

9.17.2 `_GCP` (Get Capability)

This object is required and provides the OSPM with a bit mask of the device capabilities. The device can implement the time function in addition to the wake function. The capabilities bitmask will indicate to the OSPM what support is implemented. If the platform implements both AC and DC timers then it is capable of waking up based on the power source.

Arguments:(0)

Return Value:

A 32-bit integer containing a result bitmask as follows:

Bit [0] - 1 = AC wake implemented, 0 = not supported

Bit [1] - 1 = DC wake implemented, 0 = not supported

Bit [2] - 1 = Get/Set real time features implemented, 0 = not supported

Bit [3] - 1 = Real time accuracy in milliseconds, 0 = Real time accuracy in seconds

Bit [4] - 1 = `_GWS` returns correct values for wakes from S4/S5 caused by timer. 0 = not supported

Bit [5] - 1 = Wake supported from S4 on AC, 0 = Wake not supported from S4 on AC

Bit [6] - 1 = Wake supported from S5 on AC, 0 = Wake not supported from S5 on AC

Bit [7] - 1 = Wake supported from S4 on DC, 0 = Wake not supported from S4 on DC

Bit [8] - 1 = Wake supported from S5 on DC, 0 = Wake not supported from S5 on DC

Bit [9] to Bit [31] are reserved and must be 0.

Note: The following rules apply for the `_GCP` returned value:

- If wake on DC is supported (bit 1), then wake from AC (bit 0) must be supported
- If wake on AC from S5 is supported (bit 6), then wake on AC from S4 must be supported (bit 5)
- If wake on AC from S4 is supported (bit 5), then wake on AC must be supported (bit 0)
- If wake on DC from S5 is supported (bit 8), then wake on DC from S4 must be supported (bit 7)
- If wake on DC from S4 is supported (bit 7), then wake on DC must be supported (bit 1)
- If wake on DC from S4 is supported (bit 7), then wake on AC from S4 must be supported (bit 5)
- If wake on DC from S5 is supported (bit 8), then wake on AC from S5 must be supported (bit 6)
- If wake from S4/S5 is supported (bits 5-8), then `_GWS` must be supported (bit 4)

9.17.3 _GRT (Get Real Time)

This object is required if the capabilities bit 2 is set to 1. The OSPM can use this object to get time. The return value is a buffer containing the time information as described below.

Arguments: (0)

Return Value:

A buffer containing the time information, in the following format:

```
Buffer() {
WORD Year;                // 1900 - 9999
BYTE Month;               // 1 - 12
BYTE Day;                 // 1 - 31
BYTE Hour;                // 0 - 23
BYTE Minute;              // 0 - 59
BYTE Second;              // 0 - 59
BYTE Valid;               // 0 - Time is not valid (request failed); 1 - Time is_
↳valid
WORD milliseconds,        // 1-1000
WORD TimeZone;           // -1440 to 1440 or 2047 (unspecified)
BYTE Daylight;
BYTE Pad2[3];             // Reserved, must be zero
}
```

9.17.4 _SRT (Set Real Time)

This object is required if the capabilities bit 2 is set to 1. The OSPM can use this object to set the time. The argument is a buffer containing the time information, as defined above.

Arguments: (1)

A buffer containing the time information, in the following format:

```
Buffer() {
WORD Year;                // 1900 - 9999
BYTE Month;               // 1 - 12
BYTE Day;                 // 1 - 31
BYTE Hour;                // 0 - 23
BYTE Minute;              // 0 - 59
BYTE Second;              // 0 - 59
BYTE Pad1;
WORD milliseconds,        // 1-1000
WORD TimeZone;           // -1440 to 1440 or 2047 (unspecified)
BYTE Daylight;
BYTE Pad2[3];             // Reserved, must be zero
}
```

Return Value:

An Integer:

0 - success 0xFFFFFFFF- Failed

Note:

Time is maintained using a battery backed time device (e.g. a real time clock).

The time will always be local time; the time zone value can be used to determine the offset from UTC.

Time zone field is the number of minutes that the local time lags behind the UTC time. (i.e. time zone = UTC - local time). The time zone is in 2's complement format.

Time zone value of 2047, means that time zone value is not specified, and no relation to UTC can be inferred.

Daylight is a bitmask containing the daylight savings time information for the time, as follows:

Bit [0]: 1 = the time is affected by daylight savings time, 0= time is not affected by daylight savings. This value does not indicate that the time has been adjusted for daylight savings time. It indicates only that it should be adjusted when the time enters daylight savings time.

Bit [1]: 1= the time has been adjusted for daylight savings time, 0= the time hasn't been adjusted for daylight savings.

All other bits must be zero.

When entering daylight saving time, if the time is affected, but hasn't been adjusted (DST = 1), use the new calculation:

- The date/time should be increased by the appropriate amount.
- The TimeZone should be decreased by the appropriate amount (EX: +480 changes to +420 when moving from PST to PDT).
- The Daylight value changes to 3.

When exiting daylight saving time, if the time is affected and has been adjusted (DST = 3), use the new calculation:

- The date/time should be decreased by the appropriate amount.
- The TimeZone should be increased by the appropriate amount.
- The Daylight value changes to 1.

9.17.5 **_GWS (Get Wake alarm status)**

This object is required if the capabilities bit 0 is set to 1. It enables the OSPM to read the status of wake alarms. Expired wake timers will wake the platform even if the transition to a sleep state was completed after the wake timer has expired. This method enables the OSPM to retrieve the status of wake timers and clear any of them if needed.

Arguments: (1)

Arg0 - Timer Identifier (Integer (DWORD)): indicates the timer to be cleared:

0x00000000 - AC Timer

0x00000001 - DC Timer

Return Value:

An Integer (DWORD) containing current expired timers in bit field

Bit [0]- 1 = timer expired, 0 = timer did not expired

Bit [1]- 1= timer caused a platform wake, 0 = timer did not cause a platform wake

Bit [31:2] reserved and should be 0.

9.17.6 **_CWS (Clear Wake alarm status)**

This object is required if the capabilities bit 0 is set to 1. It enables the OSPM to clear the status of wake alarms. Expired wake timers will wake the platform even if the transition to a sleep state was completed after the wake timer has expired. This method enables the OSPM to clear the status of expired wake timers.

Arguments:(1)

Arg0 - Timer Identifier (Integer (DWORD)): indicates the timer to be cleared:

0x00000000 - AC Timer

0x00000001 - DC Timer

Return Value:

An Integer (DWORD) containing current expired timer wake policy:

0x00000000 - Success

0x00000001 - Failure

9.17.7 **_STP (Set Expired Timer Wake Policy)**

This object is required if the capabilities bit 0 is set to 1. It sets the expired timer wake policy. The policy is applied when a corresponding timer expired but the wake signal was not asserted as a result of the power source. The platform accumulates elapsed time on the power source and asserts the wake signal when the elapsed timer on the power source exceeds the expired timer wake policy value. Power source transitions do not reset the expired timer wake policy values. When the Wake Alarm device asserts the wake, the expired timer wake policy values of both the AC timer and DC timer are reset to 0xFFFFFFFF automatically by hardware.

Arguments:(2)

Arg0 - TimerIdentifier (Integer(DWORD)): indicates the timer to be set:

0x00000000 - AC Timer

0x00000001 - DC Timer

Arg1 - ExpiredTimerWakePolicy (Integer(DWORD)): indicates the expired timer wake policy:

0x00000000 - The timer will wake up the system instantly after the power source changes.

0x00000001 - 0xFFFFFFFF: time between the power source changes and the timer wakes up the system (in units of second).

0xFFFFFFFF - The timer will never wake up the system after the power source changes.

Return Value:

An Integer containing a result code as follows:

0x00000000 - Succeeded to set the expired timer wake policy.

0x00000001 - Failed to set the timer policy. Actual timer policy unknown.

9.17.8 **_STV (Set Timer Value)**

This object is required if the capabilities bit 0 is set to 1. It sets the timer to the specified value. As defined in **_TIV**, the value indicates the number of seconds between the time when the timer is programmed and the time when it expires. When the Wake Alarm device asserts the wake signal, the timer value is automatically reset to 0xFFFFFFFF (disabled).

Arguments:(2)

Arg0 - TimerIdentifier (Integer (DWORD)): indicates the timer to be set:

0x00000000 - AC Timer

0x00000001 - DC Timer

Arg1 - TimerValue (Integer): indicates the value to be set.

Return Value:

An Integer containing a result code as follows:

0x00000000 - Succeeded to set timer value.

0x00000001 - Failed to set timer value. Actual timer value unknown.

9.17.9 **_TIP (Expired Timer Wake Policy)**

This object is required if the capabilities bit 0 is set to 1. It returns the current expired timer wake policy setting of the specified timer.

Arguments:(1)

Arg0 - TimerIdentifier (Integer (DWORD)): indicates the timer to be read:

0x00000000 - AC Timer

0x00000001 - DC Timer

Return Value:

An Integer (DWORD) containing current expired timer wake policy:

0x00000000 - The timer will wake up the system instantly after the power source changes

0x00000001 - 0xFFFFFFFF: Time between the power source changes and the timer wakes up the system (in units of seconds)

0xFFFFFFFF - The timer will never wake up the system after the power source changes

9.17.10 **_TIV (Timer Values)**

This object is required if the capabilities bit 0 is set to 1. It returns the remaining time of the specified timer before that expires.

Arguments:(1)

Arg0 - TimerIdentifier (Integer(DWORD)): indicates the timer to be read:

0x00000000 - AC Timer

0x00000001 - DC Timer

Return Value:

An Integer containing the current timer value. A value of 0xFFFFFFFF indicates that the timer is disabled.

9.17.11 ACPI Wakeup Alarm Events

The Wake Alarm, device as a generic hardware, supports control methods `_PSW` and `_PRW` to wake up the system and issues a `Notify(<device>, 0x2)` on the wakeup alarm device.

9.17.12 Relationship to Real Time Clock Alarm

Though both of the devices support wakeup timers to wake up system from sleeping state, they work independently. The Real Time Clock Alarm is defined as a fixed feature hardware whereas Time and Alarm device is defined as a generic hardware and can replace or coexist with the real time clock. OSPM may choose which device to utilize to provide timed wake capability.

9.17.13 Time and Alarm device as a replacement to the RTC

The Time and Alarm device can be an alternative to the RTC on some platforms where the legacy RTC hardware is not available, on these platforms the OSPM can use the Time and Alarm device to obtain time and set wake alarms. For platforms that don't require AC/DC wake service (e.g. a platform that have one power source only) the AC timer can be used to provide all the functions that were traditionally provided by the RTC. Using the capabilities object the Time and Alarm device can provide a scalable range of services to the OSPM.

9.17.14 Relationship to UEFI time source

The Time and Alarm device must be driven from the same time source as UEFI time services. This ensures that the platform has a consistent value of real time (time of day) and wake alarms. The OSPM can interact with this value using either ACPI or UEFI.

- OSPM must use only one runtime interface to configure/query the platform alarm(s); undefined behavior may occur if the two wakeup interfaces are used on the same hardware.
- If OSPM is trying to set an alarm using EFI runtime services, the alarm should be honored regardless of the power source (i.e. if the platform has an independent timer for each power source, they should both be configured with that alarm).

9.17.15 Example ASL code

The following ASL code serves as an example of how the Time and Alarm Device could be implemented. It is beyond the capability and the scope of this specification to provide a complete hardware implementation example.

Example 1: Define an ACPI Wake Alarm device

```
Device(\_SB.AWAK) {
    Name(_HID, "ACPI000E")           //device ID
    Name(_PRW, Package(){...})      //enable or disable to wake up the system
    OperationRegion(CMOP, EmbeddedControl, ...)
    Field(CMOP, ByteAcc, ...){
        // timer status and policies
    }
    Method(_GCP) {
        Return (0x03)                // Both AC and DC alarms are implemented;
```

(continues on next page)

(continued from previous page)

```

}
// Time capability is NOT supported
Method(_STP, 2){
  If(LEqual(Arg0, 0) {
    Store(Arg1, ...) // Set AC timer policy
  }
  Else {
    Store(Arg1, ...) // Set DC timer policy
  }
  Return(0)
}
Method(_TIP, 1){
  If(LEqual(Arg0, 1) {
    Store(..., Local0) // Get DC timer policy
  }
  Else {
    Store(..., Local0) // Get AC timer policy
  }
  Return (Local0)
}
Method(_STV, 2){
  If(LEqual(Arg0, 0) {
    Store(Arg1, ...) // Set AC timer value
  }
  Else {
    Store(Arg1, ...) //Set DC timer value
  }
  Return(0)
}
Method(_TIV, 1){
  If(LEqual(Arg0, 1) {
    Store(..., Local0) //Get DC timer value
  }
  Else {
    Store(..., Local0) //Get AC timer value
  }
  Return (Local0)
}
Method(_GWS, 1){
  If(LEqual(Arg0, 1) {
    Store(..., Local0) //Get DC timer wake status
  }
  Else {
    Store(..., Local0) //Get AC timer wake status
  }
  Return (Local0)
}
Method(_CWS, 2){
  If(LEqual(Arg0, 0) {
    Store(0, ...) //Clear AC Wake status
  }
  Else {
    Store(0, ...) //Clear DC Wake status
  }
  Return(0)
}
} // end of ACPI Wake Alarm device object

```

(continues on next page)

(continued from previous page)

```

Scope(\_GPE) {                                     // Root level event handlers
  Method(_Lxx){
    Store(One, ...)
    Notify(\_SB.AWA, 0x2)                         //notify the OSPM of device wake
  }
} // end of \_GPE scope

```

Example 2: Define an ACPI Real Time device on a HW-Reduced ACPI platform

```

Device(\_SB.I2C1)                                 //The controller used to access the RTC hardware
{
  Name (_HID, ...)
  ...                                             // Other objects required for this I2C controller
  // Track status of SPB OpRegion availability for this controller
  Name(AVBL, 0)
  Method(_REG,2)
  {
    /* 9 is the OpRegion type for SPB. (8 == GPIO, etc) */
    If (Lequal(Arg0, 9))
    1{
      Store(Arg1, ^AVBL)
    }
  }
}
Device(\_SB.TAAD) {                               //The Time and Alarm Device
  Name (_HID, "ACPI000E")
  Scope(\_SB.I2C1)                               //OpRegion declaration must appear under the_
  ↪controller
  {
    OperationRegion(TOP1, GenericSerialBus, 254, 0x100)
    Field(TOP1, BufferAcc, NoLock, Preserve)
    {
      Connection(I2CSerialBusV2(0x4a,,400000,, "\_SB.I2C1",,,,,)),
      //Connection to the controller for the following field accesses
      AccessAs(BufferAcc, AttrWord), //AccessProtocol for the following field(s)
      Y, 8,
      AccessAs(BufferAcc, AttrByte),
      M, 8,
      D, 8,
      H, 8,
      Mi,8,
      S, 8,
      P, 8,
      AccessAs(BufferAcc, AttrWord),
      Ms, 8,
      Tz, 8,
      AccessAs(BufferAcc, AttrByte),
      D1, 8,
      P2, 8
    }
  } // End of Field
} // End of Scope
Method (_GCP, 0x0, NotSerialized)
{
  Return(0x4) //Implements Real Time interface, but no alarms
}
Method(_GRT, 0x0, NotSerialized)
{

```

(continues on next page)

(continued from previous page)

```

If(LNotEqual(\_SB.TC1.AVBL, 1)) // Verify that SPB OpRegion is available
                                // for this access
{
    Return(0)
}
Name(BUFF, Buffer(4){}) // Create SerialBus data buffer as BUFF
CreateByteField(BUFF, 0x00, STAT) // STAT = Status (Byte)
CreateWordField(BUFF, 0x02, DATA) // DATA = Data (Byte)
Name(BUF2, Buffer(0x10){}) // Create buffer to hold the Real Time structure
                                //as BUF2
CreateWordField(BUF2, 0x0, Y) // Year
CreateByteField(BUF2, 0x2, M) // Month
...
CreateByteField(BUF2, 0xc, D1) // D1
CreateByteField(BUF2, 0xd, P2) // Pad2
Store(\_SB.I2C1.Y, BUFF) // Get each member from the OpRegion and store
                                // in the structure

Store(DATA, Y)
Store(\_SB.I2C1.M, BUFF)
Store(DATA, M)
...
Store(\_SB.I2C1.D1, BUFF)
Store(DATA, D1)
Store(\_SB.I2C1.P2, BUFF)
Store(DATA, P2)
Return(BUF2) // Success -> return what was last in buffer
}
Method(_SRT, 0x1, NotSerialized)
{
    Name(BUFF, Buffer(4){}) // Create SerialBus data buffer as BUFF
    CreateByteField(BUFF, 0x00, STAT) // STAT = Status (Byte)
    CreateWordField(BUFF, 0x02, DATA) // DATA = Data (Byte)
    // Verify that SPB OpRegion is available for this access
    If(LNotEqual(\_SB.I2C1.AVBL, 1))
    {
        Return(0)
    }
    CreateWordField(Arg0, 0x0, Y) // Create Fields to access each member of the
                                // input data

    ...
    CreateByteField(Arg0, 0xd, P2)
    Store(Store(Y, \_SB.I2C1.Y), BUFF) // Store each input member into the hardware,
                                // and set the transaction status into BUFF
    If(LEqual(STAT, 0x00)) // transaction was *NOT* successful
    {
        Return(0xFFFFFFFF)
    }
    ...
    Store(Store(P2, \_SB.I2C1.P2), BUFF)
    If(LEqual(STAT, 0x00)) // Transaction was \_NOT_successful
    {
        Return(0xFFFFFFFF)
    }
}
Name(_DEP, Package() {"\_SB.I2C1"}) // Identify the OpRegion dependency for
                                // this device
} // End of Time and Alarm Device definition

```

9.18 Generic Buttons Device

The-Generic-Button device is a standard device for reporting button events via hardware interrupts, and mapping those interrupts to specific usages defined in the Human Interface Device (HID) specification. In order to express the functionality of a button to the OS, two pieces of information are required: Usage of the HID Control, and Usage of the HID Collection that the Control belongs to. A Usage is a combination of a Usage Page and Usage ID. For example, the Volume Up button is identified as the Volume Up Usage (Usage Page 0x0C, Usage Id 0xE9) in the Consumer Control Collection (Usage Page 0x0C, Usage Id 0x01).

The Plug and Play ID of the Generic Button device is ACPI0011.

Note: If the Power button is described using this device, it must also support the Power Button Override feature defined in [Section 4.8.2.2.1.3](#).

Table 9.14: Generic Buttons Device Child Objects

Object	Description
_CRS	Lists the resources consumed by the Generic Button device. Only interrupt resources (GpioInt() and Interrupt()) are valid for this device. Each interrupt listed must signal one distinct button event.
_DSD	Provides a list of HID Button Descriptors, as defined by UUID FA6BD625-9CE8-470D-A2C7-B3CA36C4282E. Only HID 2-state button usages are valid for the descriptors returned for this device.

Note: If there are more HID Button Descriptors returned by _DSD than there are interrupts listed in _CRS, behavior is OS-specific.

9.18.1 Button Interrupts

Interrupts for the Generic Buttons Device are required to be edge-triggered and not level-triggered since there is no interface defined for the driver to quiesce the interrupt line once the interrupt is received. The polarity (ActiveLow/High vs. ActiveBoth) of the interrupt is determined by the Usage Type of the HID Usage associated with the interrupt, as described in the table below.

Table 9.15: Usage Types and Interrupt Polarity

Usage Type	Interrupt Polarity	Explanation
OSC - One Shot Control	ActiveHigh/ ActiveLow	An interrupt should be triggered on a button press. This is for a toggle button. On every such event (interrupt), the Operating System will toggle the internal property of the entity that it controls. Example: Mute button
MC - Momentary Control	ActiveBoth	An interrupt should be triggered on both the button press and release. Example: Left mouse button.
RTC - Re-trigger Control	ActiveBoth	An interrupt should be triggered on both the button press and release. While the button is pressed, the Operating System will repeatedly re-execute the action that it would take when the button is pressed. Example: A Volume Up button when pressed and held, will repeatedly increment the Volume.

continues on next page

Table 9.15 – continued from previous page

Usage Type	Interrupt Polarity	Explanation
OOB - On/Off Control	ActiveHigh/ ActiveLow OR ActiveBoth	ActiveHigh/ActiveLow polarity should be specified if implemented as a button that goes back to its initial state automatically. E.g. A Push Button or a spring-loaded Slider switch. Only one interrupt should be fired for press/release pair. Example: A spring-loaded Wireless Radio Slider Switch. ActiveBoth polarity should be specified if implemented as a button that stays in its state until the user moves it again. E.g. A button that stays in pressed state, or a Slider switch that sticks to its position. Example: Wireless Radio Slider Switch.

9.18.2 Button Usages and Collections

The HID Usage tables have an extensive list of Standardized Usages for various kinds of buttons. Some of the common buttons found on Computing devices and their Usages are listed in the table below.

For the full list, see “HID Usage Tables”, available from “Links to ACPI-Related Documents” (<http://uefi.org/acpi>) under the heading “HID Usage Tables”.

Buttons are grouped under an HID Collection. Several HID Collections are commonly understood by Operating Systems, e.g., Keyboard Collection, Consumer Controls Collection, Wireless Radio Controls Collection, etc.

Table 9.16: Common HID Button Usages

Button	Usage Page / Usage	Usage Type	Interrupt Polarity	Spec Reference
Power	Generic Desktop Page (0x01) System Power Down (0x01)	OSC	ActiveBoth *	USB HID Usage Tables, version 1.2: see https://www.usb.org/hid , under the heading <i>HID Usage Tables</i>
Volume Up	Consumer Page (0x0C) Vol- ume Increment (0xE9)	RTC	ActiveBoth	USB HID Usage Tables, version 1.2: see https://www.usb.org/hid , under the heading <i>HID Usage Tables</i>
Volume Down	Consumer Page (0x0C) Vol- ume Decrement (0xEA)	RTC	ActiveBoth	USB HID Usage Tables, version 1.2: see https://www.usb.org/hid , under the heading <i>HID Usage Tables</i>
Camera Shutter	Camera Control Page (0x90) Camera Shutter (0x21)	OSC	Active High/ Active Low	USB Review Request 49: Camera Controls - see https://www.usb.org/hid , under the heading <i>Approved Usage Table Review Requests</i>
Display Brightness Up	Consumer Page (0x0C) Dis- play Brightness Increment (0x6F)	RTC	ActiveBoth	USB Review Request 41: Display Brightness Controls - see https://www.usb.org/hid , under the heading <i>Approved Usage Table Review Requests</i>

continues on next page

Table 9.16 – continued from previous page

Button	Usage Page / Usage	Usage Type	Interrupt Polarity	Spec Reference
Display Brightness Down	Consumer Page (0x0C) Display Brightness Decrement (0x6F)	RTC	ActiveBoth	USB Review Request 41: Display Brightness Controls - see https://www.usb.org/hid , under the heading <i>Approved Usage Table Review Requests</i>
Wireless Radio Button	Generic Desktop Page (0x01) Wireless Radio Button (0xC6)	OOC	ActiveHigh/ActiveLow	USB Review Request 40: HID Radio On/Off Usages - see https://www.usb.org/hid , under the heading <i>Approved Usage Table Review Requests</i>
Wireless Radio Slider Switch	Generic Desktop Page (0x01) Wireless Radio Slider Switch (0xC8)	OOC	ActiveBoth	USB Review Request 40: HID Radio On/Off Usages - see https://www.usb.org/hid , under the heading <i>Approved Usage Table Review Requests</i>

Note: * The System Power Down Usage (Page:01, ID: 81) has Type OSC, although its interrupt must be ActiveBoth in order to allow drivers to perform functions based on “hold-down” timing. This is an exception to the Usage Type Rules for Interrupt Polarity (see Table 9.15).

9.18.3 Generic Buttons Device Example

```
Device (BTNS)
{
Name (_HID, "ACPI0011")
Name (_CRS, ResourceTemplate() {
    GpioInt(Edge, ActiveBoth...) {pin} //Vol Down
    GpioInt(Edge, ActiveBoth...) {pin} //Vol Up
    GpioInt(Edge, ActiveBoth,...) {pin} //Power (MUST BE ACTIVEBOTH!)
})
Name (_DSD, Package(2) {
    //UUID for HID Button Descriptors:
    //ToUUID("FA6BD625-9CE8-470D-A2C7-B3CA36C4282E"),
    //Data structure for this UUID:
Package() {
    Package(5) {
        0, //Declare a Collection
        1, //Unique ID for this collection
        0, //It is a top-level collection
        0x0c, //Usage Page ("Consumer")
        0x01 //Usage ("Consumer Control")
    },
    Package(5) {
        0, //Declare another Collection
        2, //Unique ID for this collection
        0, //Also a top-level collection
        0x01, // Usage Page ("Generic Desktop")
        0x80 //Usage ("System Control")
    },
}
```

(continues on next page)

(continued from previous page)

```

Package(5) {
    1,          //Declare a Control
    0,          //Interrupt index in \_CRS for Vol Down
    1,          //In the "Consumer Control" collection
    0x0c,       //Usage Page ("Consumer")
    0xEA        //Usage ("Volume Decrement")
},
Package(5) {
    1,          //Declare another Control
    2,          //Interrupt index for the Power Button
    2,          //In the "System Control" collection
    0x01,       //Usage Page ("Generic Desktop")
    0x81        //Usage ("System Power Down")
},
Package(5) {
    1,          //Declare another Control
    1,          //Interrupt index for the Vol Up button
    1,          //In the "Consumer Control" collection
    0x0c,       //Usage Page ("Consumer")
    0xE9        //Usage ("Volume Increment")
},
Package(5) {
    1,          //Another Control
    0xFF,       //No Interrupt for this one... e.g. OS-
                // specific signaling for Rotation Lock
    1,          //In the "Consumer Control" collection
    0x0C,       //Usage Page ("Consumer")
    0x245       //Usage ("AC Rotate")
}
}
})
} // End Device

```

9.19 NVDIMM Devices

9.19.1 Overview

In order to handle NVDIMMs, the OS must first be able to detect and enumerate the NVDIMMs. To facilitate the plug and play discovery of NVDIMM and driver loading, ACPI namespace devices are used.

9.19.2 NVDIMM Root Device

The NVDIMM root device is represented by an ACPI namespace device with an `_HID` of “ACPI0012” (see [Section 6.1.5](#) and [Table 5.205](#)). If the platform supports NVDIMMs, then platform firmware shall report one NVDIMM root device in the SB scope (see [Section 5.3.1](#)). This device allows the OS to trigger enumeration of NVDIMMs through NFIT (see [Table 5.126](#)) at boot time and re-enumeration at root level via the [Section 6.5.9](#) during runtime.

For each NVDIMM present or intended to be supported by platform, platform firmware also exposes an NVDIMM device (see [Section 9.19.3](#)) under the NVDIMM root device.

9.19.3 NVDIMM Device

Each NVDIMM is represented by an ACPI namespace device under the NVDIMM root device (see [Section 9.19.2](#)) with an `_ADR` (see [Section 6.1.1](#)) containing the NFIT Device Handle. The NFIT Device Handle is a 32-bit value. Bit [31] indicates the format of the NFIT Device Handle.

If Bit [31] is clear, then Bits [30:0] are defined as follows:

- Bits [3:0] DIMM number within the memory channel
- Bits [7:4] memory channel number within the memory controller
- Bits [11:8] memory controller ID within the socket
- Bits [15:12] socket ID within the node controller, if any
- Bits [27:16] node controller ID, if any
- Bits [31:28] Reserved

If Bit [31] is set, then Bits [30:0] are defined as follows:

- Bits [30:0] platform unique value assigned by the platform firmware that is consistent across boots when the NVDIMM is in the same physical location but may change if the NVDIMM is in a different physical location.

NOTE: Bit 31 was introduced in ACPI Specification 6.4, so software compliant with previous versions of ACPI might parse the structure as if bit [31] is set to zero.

[Table 5.196](#) defines NVDIMM Device Notification Values for an NVDIMM device.

Information about the Label Storage Area on the NVDIMM is provided by the `_LSI` (see [Section 6.5.10.1](#)) method. The OSPM uses the methods `_LSR` (see [Section 6.5.10.2](#)) and `_LSW` (see [Section 6.5.10.3](#)) to read and write to the Label Storage Area. The format of the Label Storage Area data is defined in UEFI.

9.19.4 Example

An example name space is shown below for a platform containing one NVDIMM:

```
Scope (\_SB){
Device (NVDR)           // NVDIMM root device
{
    Name (_HID, "ACPI0012")
    Method (_STA) {...}
    Method (_FIT) {...}
    Method (_DSM, ...) {
        ...
    }
Device (NVD)           // NVDIMM device
{
    Name(_ADR, h)       //where h is NFIT Device Handle for this NVDIMM
    Method (_DSM, ...) {
        ...
    }
}
}
}
```

9.19.5 Loading NVDIMM drivers

While using ACPI namespace devices allows for OS handling of NVDIMMs in a standard manner, the format of the address ranges described by this scheme may still vary depending on the vendor (or even different NVDIMM version of the vendor). For example, the command and status values supported by a Block Control Window are vendor specific and possibly even vary for a given vendor.

The NVDIMM Control Region Structure (see Section 5.2.26.6) includes a Vendor ID, Device ID, and Revision ID. Because an NVDIMM could be a combination device consisting of different region types (e.g. Persistent Memory and Block), a Region Format Interface Code is also included to indicate the region type as well as the specific implementation within that type. This allows for variability across vendors as well as within vendor offerings.

These fields enable loading of drivers for managing the NVDIMM as well as for handling the address ranges supported by the NVDIMM. The Region Format Interface Code is used to load generic drivers for the following: management driver, persistent memory driver and block driver. A vendor specific driver for each of the above can be loaded by matching on Vendor ID, Device ID and Revision ID (in addition to the Region Format Interface Code).

Region Format Interface Code requirements shall be met by all compliant NVDIMMs. Any Vendor specific extensions are only allowed to extend on top of the Region Format Interface Code requirements.

It is assumed that the OSPM is capable of loading the Region Format Interface Code specific driver or vendor specific drivers based on such discovery. This scheme is as shown in the following figure.

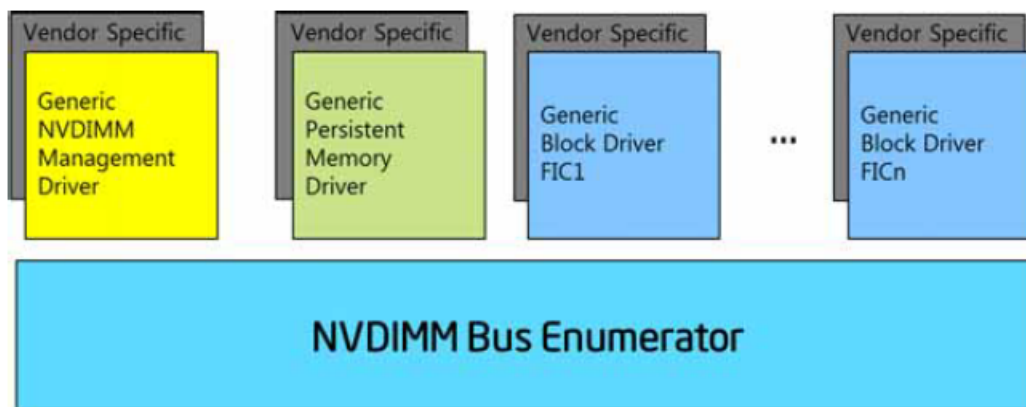

Fig. 9.8: Vendor/Device Specific Driver Loading

The Subsystem Vendor ID, Subsystem Device ID and Subsystem Revision ID fields allow selection of specific solution provider drivers that may span across devices from multiple vendors.

9.19.6 Hot Plug Support

The NVDIMM memory hot plug representation of the ACPI Name Space is described in this section. The NVDR device is the NVDIMM root device, the NVD1 and NVD2 are NVDIMM devices, the MEM0 is memory module device corresponding to the NVD1 and NVD2 devices. The `_FIT` method under NVDR device returns all NFIT entries including the hot added devices.

```
Device (NVDR) // Root device
{
  Name (_HID, "ACPI0012")
  Method (_STA) {...}
  Method (_FIT) {...}
  Method (_DSM, ...) {
```

(continues on next page)

(continued from previous page)

```

...
}
Device (NVD1)                // NVDIMM1
{
    Name (_ADR, h1)           // where h1 is NFIT Device Handle for this NVDIMM1
    Method (_DSM, ...) {
        ...
    }
}
Device (NVD2)                // NVDIMM2
{
    Name (_ADR, h2)           // where h2 is NFIT Device Handle for this NVDIMM2
    Method (_DSM, ...) {
        ...
    }
}
}

Device (MEM0)                // Memory module
{
    Name (_HID, EISAID ("PNP0C80"))
    Method (_STA) {...}
    Method (_CRS) {...}
}

Scope (\_GPE)
{
    Method (_L00) {
        Notify (\_SB.NVDR, 0x80) // Notify to NVDIMM root device
        Notify (\_SB.MEM0, 1)    // Device Check to Memory Module
    }
}
}

```

Hot Plugged memory is indicated to OS using ACPI Name Space device with PNPID of PNP0C80. The NFIT entries created by the hot plug NVDIMM are communicated by the ACPI Name Space device with ACPI0012.

NVDIMM hot add flow:

1. Prior to hot add of the NVDIMM, the corresponding ACPI Name Space devices, NVD1, NVD2 return an address from `_ADR` object (NFIT Device handle) which does not match any entries present in NFIT (either the static or from `_FIT`) indicating that the corresponding NVDIMM is not present. Further ACPI Name Space Device MEM0 returns `_STA` status of 0 indicating that the devices are not present, not enabled and not functioning.
2. On hot add:
 - a. Send Notify 0x80 to NVDR to cause NVDIMM bus driver to enumerate all the devices under the root hierarchy
 - b. NVDIMM bus driver evaluates the `_FIT` method under the NVDR device and identifies the changes to the NVDIMM devices present (by identifying new NFIT Device handles that have been added).
 - c. NVDIMM bus driver now finds matching entries for addresses returned by `_ADR` objects of NVD1 and NVD2 and loads the corresponding drivers.
 - d. Send Notify Device Check to MEM0 to cause re-enumeration of device causing the memory manager to add `_CRS` range to the memory pool.
3. MEM0 will now report all the memory ranges now created and made visible.

9.19.7 NVDIMM Root Device _DSMs

A device specific method (_DSM) for an NVDIMM root device is described below.

9.19.7.1 Input Parameters:

Arg0 - *UUID* (set to 2f10e7a4-9e91-11e4-89d3-123b93f75cba)

Arg1 - *Revision ID* (set to 1)

Arg2 - *Function Index*

Table 9.17: NVDIMM Root Device Function Index

Function Index	Description
0	Query command implemented (see Section 9.1.1)
1	Query Address Range Scrub (ARS) Capabilities (see Section 9.19.7.4)
2	Start Address Range Scrub (ARS) (see Section 9.19.7.5)
3	Query Address Range Scrub (ARS) Status (see Section 9.19.7.6)
4	Clear Uncorrectable Error (see Section 9.19.7.7)
5	Translate SPA
6	Reserved
7	ARS Error Inject
8	ARS Error Inject Clear
9	ARS Error Inject Status Query
0xA	Query ARS Error Inject Capabilities
0xB - 0xFFFF	Reserved

Arg3 - a package containing parameters for the function specified by the *UUID*, *Revision ID*, and *Function Index*. The layout of the package for each command along with the corresponding output is illustrated in the following tables. The input and output package are a list of bytes (Buffer).

9.19.7.2 Address Range Scrubbing (ARS) Overview

ARS allows the platform to communicate memory errors to system software. This capability allows system software to prevent accesses to addresses with uncorrectable errors in memory.

The ARS functions are system scope and are not specific to a single NVDIMM, i.e., they manage all NVDIMMs present in the system.

The **Query ARS Capabilities** function indicates if ARS is supported for an address range and to discover system-wide attributes, such as the maximum amount of data that can be returned from a **Query ARS Status** function and whether the platform provides an asynchronous ACPI notification that a new uncorrectable error has been discovered.

Only one scrub can be in progress system wide at any given time. OSPM should first issue a **Query ARS Status** function and ensure no ARS is in progress before issuing a **Start ARS** function. If a successful status is returned, the extended status of the **Query ARS Status** function indicates to OSPM one of the following:

- An ARS has been completed and ARS results are returned. These results should be processed by OSPM before issuing another **Start ARS** function. When a new address range scrub operation is started, the previous ARS results are lost.
- An ARS is in progress and no ARS results are returned. A **Start ARS** function fails while an ARS is in progress. OSPM should periodically issue **Query ARS Status** functions until the ARS is no longer in progress.

- There has been no ARS since the platform was booted so there are no ARS results returned. A new **Start ARS** function may be issued.
- An ARS stopped prematurely and partial results are returned. If the platform has more data to return than will fit in the Max Query ARS Status Output Buffer Size (see [Section 9.19.7.4](#)). OSPM may issue **Start ARS** and **Query ARS Status** functions in a loop and retrieve all of the ARS Error Records, modifying the ARS Start SPA Address and length with each iteration.

If a **Start ARS** function is issued, the OSPM provides the ARS Start SPA Address and ARS Length for the range to be scrubbed. If the previous ARS stopped prematurely, these fields should be set to the values from the Restart ARS Start SPA Address and Restart ARS Length from the previous **Query ARS Status** output buffer. For any **Start ARS** function, OSPM may optionally set the Flags Bit[0] to indicate to the platform that the ARS is a priority and may cause delays in other processing, such as when booting. The output from a successful **Start ARS** function provides an estimated time for the scrub to complete as a hint to the OSPM regarding when to issue a **Query ARS Status** function.

As indicated in the **Query ARS Capabilities** function output, a platform may issue the asynchronous event notification 0x81 (Unconsumed Uncorrectable Memory Error Detected Notification) when new uncorrectable errors are detected. Upon receiving the notification, the OSPM may decide to issue a **Start ARS** with Flags Bit [1] set to prepare for the retrieval of existing records and issue the **Query ARS Status** function to retrieve the records. The OSPM can pass the entire range of persistent memory as ‘ARS Start SPA Address’ and ‘ARS Length’ for **Start ARS**, even if the persistent memory range is not contiguous. Alternatively, the OSPM may decide to ignore event notification 0x81. If the memory range is accessed before OSPM can process the ARS data, default platform error handling sequences, such as Machine Check, may occur.

Platforms may support the ability for OSPM to clear an error previously reported from an ARS. OSPM should only issue the **Clear Uncorrectable Error** function for a memory address range if that the address range has been retired from further use or if valid error-free data is written to the range before those locations are read. If the **Clear Uncorrectable Error** function is not supported by the platform or if a **Clear Uncorrectable Error** function for an address range fails, the OSPM should continue to prevent accesses to the address ranges.

The ARS related functions use the following convention for the Status and Extended Status fields.

9.19.7.3 Address Range Scrub (ARS) Error Injection Overview

The expected OSPM ARS Error Injection flow is:

1. Inject an error with ARS Error Inject.
2. Optionally and if ARS Unconsumed Uncorrectable Memory Error Detected Notification is supported by the host, system firmware triggers an ACPI NVDIMM root device notification 0x81 for the OSPM.
3. Use Start ARS with Flags Bit[1] set for OSPM acknowledgment of the notification to system firmware and use ARS Query Status to query ARS status.
4. Optionally, use ARS Error Inject Status Query to query the error injected ranges.
5. Use ARS Error Inject Clear to clear the ARS error injected ranges. Until the error is cleared, system firmware will report the error in the ARS Query Status output buffer.

Table 9.18: Status and Extended Status Field Generic Interpretations

Bytes	Field Name	Description
1-0	Status	0 - Success 1 - Function Not Supported 2 - Invalid Input Parameters 3 - Hardware Error 4 - Retry Suggested; it is up to the OSPM regarding the number of retries to perform. 5 - Error - Unknown Reason 6 - Function-Specific Error Code 7 - FFFFh Reserved for errors
3-2	Extended Status	Function Specific

Note: If Status is nonzero, the Output Buffer for all the functions in the *_DSM (Device Specific Method)* is limited to only the Status and Extended Status fields.

9.19.7.4 Function Index 1 - Query ARS Capabilities

This function provides ARS capabilities for a given address range. The format of the input and output for this function is given below.

9.19.7.4.1 Function Input

Table 9.19: Query ARS Capabilities - Input Buffer

Field	Byte Length	Byte Offset	Description
ARS Start SPA Address	8	0	Starting of System Physical Address of ARS
ARS Length	8	8	

9.19.7.4.2 Function Output

Table 9.20: Query ARS Capabilities - Output Buffer

Field	Byte Length	Byte Offset	Description
Status	2	0	Defined in Table 9.18. All other fields in this structure are Reserved if Status is not set to 0 (Success).

continues on next page

Table 9.20 – continued from previous page

Field	Byte Length	Byte Offset	Description
Extended Status	2	2	<p>Bit[0] - If set to 1, indicates scrub of Volatile Memory is supported. Volatile memory is any region that is not marked as Persistent Memory in UEFI or in an ACPI Address Range Type.</p> <p>Bit[1] - If set to 1, indicates scrub of Persistent Memory is supported. Persistent Memory is any region that has one of the following memory range types:</p> <ul style="list-style-type: none"> - UEFI memory type of EfiPersistentMemory - Any UEFI memory type that has the EFI_MEMORY_NV memory attribute set - ACPI Address Range Type of AddressRange PersistentMemory <p>Bits[15:2] - Reserved</p>
Max Query ARS Status Output Buffer Size	4	4	<p>In bytes. Maximum size of buffer (including the Status and Extended Status fields) returned by the Query ARS Status function. This can be used to calculate the maximum number of ARS Error Records that are supported. This value shall be a constant for the platform, independent of the input SPA range. As long as a valid input SPA range is specified, the value returned for this shall always be the same.</p>
Clear Uncorrectable Error Range Length Unit Size	4	8	<p>In bytes.</p> <ul style="list-style-type: none"> - This field describes the uncorrectable error clearing unit size. This value shall be a power of two. - The Clear Uncorrectable Error Range Length argument to the Clear Uncorrectable Errors LSM function shall be an integer multiple of this unit size. - The Query ARS Status ARS Error Record Format “Length” field shall be an integer multiple of this unit size. - The ARS Error Inject SPA Range Length argument to the ARS Error Inject DSM function shall be an integer multiple of this unit size. - This value shall be a constant for the platform, independent of the input SPA range.
Flags	2	12	<p>Bit[0] - Unconsumed Uncorrectable Memory Error Detected Notification flag. If set to 1, indicates platform supports the ACPI NVDIMM Root Device Unconsumed Error Notification (0x81) as described in <i>nvdimm-root-device-notification-values</i>. If set to 0, the platform doesn’t support this notification mechanism.</p> <p>Bit[1] - ARS Stopped Notification flag. If set to 1, indicates the platform supports ARS Stopped Notification (0x82) as described in <i>NVDIMM Root Device Notification Values</i>. If set to 0, the platform does not support this notification.</p> <p>Bit[15-2] - Reserved.</p>

continues on next page

Table 9.20 – continued from previous page

Field	Byte Length	Byte Offset	Description
Reserved	2	14	
Clear Uncorrectable Error Max Range Length	4	16	In bytes. - Allows the platform to report max number of bytes that can be cleared of uncorrectable errors at a time. - This value shall be an integer multiple of the unit size, Query ARS Capabilities Clear Uncorrectable Error Range Length Unit Size
Reserved1	4	20	

9.19.7.5 Function Index 2 - Start ARS

The Start ARS function triggers an Address Range Scrub for the given memory range. Address scrubbing can be done for volatile memory, persistent memory, or both. For the given input ARS Start SPA and length, there may be one or more ranges, including gaps between them for the given Type parameter.

9.19.7.5.1 Function Input

Table 9.21: Start ARS - Input Buffer

Field	Byte Length	Byte Offset	Description
ARS Start SPA Address	8	0	In bytes
ARS Length	8	8	In bytes
Type	2	16	Bit[0] - If set to 1, Scrub Volatile Memory Bit[1] - If set to 1, Scrub Persistent Memory Bits[15:2] Reserved - Note: If the range provided includes both volatile and persistent sub-ranges, only the types indicated here will be scrubbed.
Flags	1	18	Bit[0] - If set to 1 specifies that the platform may cause delays in processing other operations while performing the ARS (e.g., for use during system boot). If set to 0 specifies that the platform shall not cause delays in processing other operations while performing the ARS (e.g., for use during run time). Bit[1]: If set to 1 the firmware shall return data from a previous scrub, if any, without starting a new scrub. If set to 0 firmware shall start a new ARS.
Reserved	5	19	

9.19.7.5.2 Function Output

Table 9.22: Start ARS - Output Buffer

Field	Byte Length	Byte Offset	Description
Status	2	0	6 - ARS already in progress All other values defined in <i>Status and Extended Status Field Generic Interpretations</i>
Extended Status	2	2	Reserved
Estimated Time for Scrub	4	4	In seconds Estimated time to scrub the given address range.

9.19.7.6 Function Index 3 - Query ARS Status

The *Query ARS Status* command allows software to get the status of ARS.

If the platform supports ARS error injection, then it shall also include injected errors as part of its payload.

9.19.7.6.1 Function Input

None

9.19.7.6.2 Function Output

Table 9.23: Query ARS Status - Output Buffer

Field	Byte Length	Byte Offset	Interpretation
Status	2	0	Defined in <i>Status and Extended Status Field Generic Interpretations</i>
Extended Status	2	2	0 - ARS complete 1 - ARS in progress. Any returned ARS data shall be all zeros. 2 - No ARS performed for current boot. Any returned ARS data shall be all zeros. 3 - ARS Stopped Prematurely - This may occur when the implementation reaches the maximum number of errors that can be reported. 4 ..0xFFFF- Reserved. Any returned ARS Data shall be all zeros.
ARS Data	Varies	4	See <i>ARS Data</i> .

The output SPA range return indicates the scope of the ARS scrub for the specified type.

Table 9.24: ARS Data

Field	Byte Length	Byte Offset	Interpretation
Output (Size)	4	0	Size of Output Buffer in bytes, including this field.
Start SPA	8	4	In bytes

continues on next page

Table 9.24 – continued from previous page

Field	Byte Length	Byte Offset	Interpretation
Length	8	12	In bytes ARS performed range is from Start SPA to Start SPA + Length
Restart ARS Start SPA Address	8	20	Starting SPA to restart the ARS if Status is Success and Extended Status was reported as ARS Stopped Prematurely. The value specified here is used without modification as the ARS Start SPA Address when calling Start ARS to continue an ARS that stopped prematurely before completing the requested ARS Length. Note: It is not required to continue an ARS that has stopped prematurely.
Restart ARS Length	8	28	SPA Length to restart the ARS if Status is Success and Extended Status was reported as ARS Stopped Prematurely. The value specified here is used without modification as the ARS Length when calling Start ARS to continue an ARS that stopped prematurely before completing the requested ARS Length.
Type	2	36	Bit[0] - Volatile Memory range if set to 1 Bit[1] - Persistent Memory range if set to 1. If both bit[0] and bit[1] are set, both Persistent Memory and volatile memory are in this range. Bits[15:2] - Reserved
Flags	2	38	Bit[0] - If set to 1, indicates an overflow condition has occurred. This means that more errors were reported in the error log than will fit in the maximum total buffer size of Max Query ARS Status Data Size from the Query ARS Capabilities. The returned Extended Status should be ARS Stopped Prematurely when this bit is set to 1. Bits[15:1] Reserved
Number of Error Records	4	40	Number of ARS Error Record structures reported
ARS Error Records	Varies	44	See the next table below for the the format of the ARS error record.

Table 9.25: ARS Error Record Format

Field	Byte Length	Byte Offset	Description
NFIT Handle	4	0	NFIT Handle indicates the specific NVDIMM at Start SPA of Error Location (offset 8)
Reserved	4	4	Reserved
Start SPA of Error Location	8	8	Start of System Physical Address of the error.

continues on next page

Table 9.25 – continued from previous page

Field	Byte Length	Byte Offset	Description
Length	8	16	Length indicates the consecutive bytes from Start SPA of Error Location that are in error. Due to interleaving, the range covered by Start SPA of Error Location and Length may include addresses that are present in other NVDIMMs in an interleave set. In case of overflow, the address range indicated by Start SPA of Error Location and Length will cover the NVDIMM interleave set that is impacted by the error. The range covered by Start SPA of Error Location and Length may exceed the requested scrub range due to platform limitations.

9.19.7.7 Function Index 4 - Clear Uncorrectable Error

The Clear Uncorrectable Error Function allows system software to clear uncorrectable errors from the NVDIMM based on System Physical Address (SPA). Uncorrectable errors reported by the Query ARS Status function can be cleared utilizing this mechanism.

For each uncorrectable error range length covered by the specified SPA range that contains an uncorrectable error, platform software shall clear the error and may modify the data at those addresses. For each uncorrectable error range length covered by the specified SPA range that does not contain an uncorrectable error, platform software shall do nothing.

The Clear Uncorrectable Error SPA Range Base shall be aligned to the Clear Uncorrectable Error Range Length Unit Size and the Clear Uncorrectable Error Range Length must be an integer multiple of the Clear Uncorrectable Error Range Length Unit Size. The Clear Uncorrectable Error request shall result in an Invalid Parameter error status if these rules are not followed.

Attempting to clear an error with a range length that overruns the end of a region shall result in an Invalid Parameter error status.

Attempting to clear an error with a range length that is greater than the range of uncorrectable errors is not considered a failure.

Attempting to clear an error from an address that does not currently have an uncorrectable error is not considered a failure.

Note: The data contained in the locations that are cleared with this command are indeterminate. Care must be taken when using this command since once the error has been cleared, subsequent reads of those cleared locations will cause silent data corruption if software is unaware that the original contents were lost. Software should only utilize this command if it can guarantee that the locations have been retired from further use or will be written with valid data before the locations are read.

OSPM may call **Clear Uncorrectable Error** on an ARS error range that was injected via the ARS Error Inject function. If the platform supports this, it should ultimately treat it as if the **ARS Error Inject Clear** function was called. If the platform does not support this, it should fail with an Invalid Input Parameter error.

9.19.7.7.1 Function Input

Table 9.26: Clear Uncorrectable Error - Input Buffer

Field	Byte Length	Byte Offset	Description
Clear Uncorrectable Error SPA Range Base	8	0	In bytes Starting location from which to clear the uncorrectable error. This address should be aligned to the Clear Uncorrectable Error Range Length Unit Size reported in the Query ARS Capabilities function (see <i>Function Index 1 - Query ARS Capabilities</i>).
Clear Uncorrectable Error Range Length	8	8	In bytes Length of the region to clear the uncorrectable error from. This length should be an integer multiple of the Clear Uncorrectable Error Range Length Unit Size reported in the Query ARS Capabilities function (see <i>Function Index 1 - Query ARS Capabilities</i>).

9.19.7.7.2 Function Output

Table 9.27: Clear Uncorrectable Error - Output Buffer

Field	Byte Length	Byte Offset	Description
Status	2	0	Defined in <i>Status and Extended Status Field Generic Interpretations</i> .
Extended Status	2	2	Reserved
Reserved	4	4	Reserved
Cleared Uncorrectable Error Range Length	8	8	The range of errors actually cleared by the platform, starting from the requested Clear Uncorrectable Error SPA Range Base. This length shall be an integer multiple of the Clear Uncorrectable Error Range Length Unit Size reported in the Query ARS Capabilities function (see <i>Function Index 1 - Query ARS Capabilities</i> Note: This range length may be smaller than the length requested by the input range length.

9.19.7.8 Function Index 5 - Translate SPA

This command instructs the platform to translate the requested System Physical Address (SPA) in to one or more NVDIMM devices consisting of an NFIT Device Handle and Device Physical Address (DPA) on that device.

- The SPA address to translate must lie within one of the SPA ranges described in the NFIT System Physical Address Range table.
- For non-mirrored interleave sets, the SPA address will translate to a single NVDIMM and single DPA.
- For a HW mirrored interleave set, the Flags Bit[0] - Mirrored SPA Location bit is set and all NVDIMM Devices the SPA translates to are included in the returned NVDIMM Device List.

9.19.7.8.1 Function Input

The following table outlines the expected input payload for this command.

Table 9.28: Translate SPA - Input Payload Format

Field	Byte Length	Byte Offset	Description
SPA	8	0	System Physical Address to translate. This is a byte aligned address and all bits are considered valid. No masking or shifting occurs.

9.19.7.8.2 Function Output

The following tables outline the expected output payload for this command.

Table 9.29: Translate SPA - Output Payload Format

Field	Byte Length	Byte Offset	Description
Status	2	0	Defined in <i>Status and Extended Status Field Generic Interpretations</i> . If the SPA does not lie within one of the SPA ranges described in the NFIT System Physical Address Range table, a status of 2, Invalid Input Parameter, is returned. All other fields in this structure are Reserved if Status is not set to 0 (i.e., Success).
Extended Status	2	2	Extended Status Field (Vendor Defined)
Flags	1	4	Bit[0] - Mirrored SPA Location - If set to 1, indicates the SPA location maps to one or more NVDIMMs that are mirrored together and contributing to a single SPA range. All NVDIMMs currently contributing to the HW Mirror shall be reported and the Number of NVDIMMs shall report all of the devices in the Mirrored SPA range.
Reserved	3	5	Must be 0
Translated Length	8	8	The number of bytes the returned SPA translation applies to. The SPA range defined by the input SPA + output Translated Length - 1 will yield an address translation with a constant Translated NVDIMM Device List containing a constant set of NFIT Device Handles.
Number of NVDIMMs	4	16	The number of NVDIMM devices being returned in the list of Translated NVDIMM Devices. This is typically 1 for a given SPA location but for Mirrored SPA Locations, it is possible to have multiple NVDIMMs that provide the same SPA.
Translated NVDIMM Device List	Varies	20	List of one or more Translated NVDIMM Devices

9.19.7.8.3 Translated NVDIMM Device

Table 9.30: Translate SPA - Translated NVDIMM Device List Output Payload Format

Field	Byte Length	Byte Offset	Description
NFIT Device Handle	4	0	Handle to physical NVDIMM that the SPA maps to. This handle can be utilized to retrieve other NFIT table data that further describes the physical device.
Reserved	4	4	Returned as zero
DPA	8	8	Device Physical Address that the SPA translates to.

9.19.7.9 Function Index 7 - ARS Error Inject

ARS Error Inject allows the injection of an error for the memory range in the defined input payload. Input is a package containing a single buffer, where the buffer is formatted as shown in *ARS Error Inject - Input Format*.

9.19.7.9.1 Input (Arg3)

Table 9.31: ARS Error Inject - Input Format

Field	Byte Length	Byte Offset	Description
ARS Error Inject SPA Range Base	8	0	Starting location from which to inject the error.
ARS Error Inject SPA Range Length	8	8	In bytes Length of the region to inject the error from. If Length makes the range cross NVDIMM SPA ranges, the system firmware implementation may report more than one ARS error record in the output buffer of the ARS Query Status _DSM function.
ARS Error Inject Options	1	16	<p>Bit 0: Unconsumed Uncorrectable Memory Error Detected Notification. Set to 1 Firmware shall notify the OSPM. Set to 0 the notification will not occur.</p> <p>Bit 1: Force Overflow. Set to 1 to trigger a Query ARS Status overflow condition with this range. A value of 0 is ignored. See below for details.</p> <p>Bit 2: Persistent Error. Set to 1 to persist this error across reboots. These are uncorrectable errors injected to specified memory locations. Set to 0 to ensure this error is cleared on reboot.</p> <p>Bits 7-3: Reserved.</p>

OSPM can trigger a Query ARS Status overflow condition by setting the Force Overflow bit (bit 1) in the ARS Error Inject Options in the input structure.

If the Force Overflow bit is set to 0 then the platform may still trigger an overflow condition if necessary (e.g. the number of error records to return from Query ARS Status exceeds Query ARS Status Data Size).

The typical sequence to force an overflow condition is as follows:

1. OSPM calls ARS Error Inject to inject an error for a particular range and sets the following fields in

the input structure:

- a. ARS Error Inject Options bit 0 to 0 so that the Unconsumed Uncorrectable Memory Error Detected notification does not occur for this range.
 - b. ARS Error Inject Options bit 1 set to 1 to indicate system firmware should force an overflow condition when it encounters this range.
2. OSPM injects a second error with ARS Error inject, setting ARS Error Inject Options bit 0 to 1 and clearing bit 1 to 0.
 3. System firmware notifies the OSPM of the new errors with the Unconsumed Uncorrectable Memory Error Detected notification.
 4. OSPM calls Query ARS Status in response to the notification.
 5. When system firmware encounters the first injected range, it sees that ARS Error Inject Options bit 1 was set and sets Flags bit 0 to 1 in the output ARS Data to indicate an overflow condition. System firmware also sets the Restart ARS Start SPA Address and Restart ARS Length accordingly.
 6. OSPM calls Start ARS with the following fields set in the input structure:
 - a. Flags bit 1 set to 1 to indicate it does not want to initiate a new scrub.
 - b. ARS Start SPA Address set to the Restart ARS Start SPA Address from the Query ARS Status output.
 - c. ARS Length set to the Restart ARS Length from the Query ARS Status output.
 7. OSPM calls Query ARS Status.
 8. System firmware returns the second injected range.

When the Persistent Error bit is set, the error range and the ARS Error Inject Options bits should persist across reboots.

9.19.7.9.2 Output

Return Value for this function is a buffer formatted as shown in the table below.

Table 9.32: ARS Error Inject - Output Format

Field	Byte Length	Byte Offset	Description
Status	2	0	Bytes[1-0] 0 - Success 1 - Not Supported. The ARS Error Inject method is not supported by the platform. 2 - Invalid Input Parameters. Platform reports that the SPA range parameters passed to the ARS Error Inject method are invalid or if notification is not supported.
Extended Status	2	2	Reserved

9.19.7.10 Function Index 8 - ARS Error Inject Clear

ARS Error Clear allows the clearing of the injected error state in the persistent memory range in the defined input payload.

9.19.7.10.1 Input (Arg3)

Input is a package containing a single buffer, where the buffer is formatted as shown in the table below.

Table 9.33: ARS Error Inject Clear - Input Format

Field	Byte Length	Byte Offset	Description
ARS Error Inject Clear SPA Range Base	8	0	
ARS Error Inject Clear SPA Range Length	8	8	In bytes

9.19.7.10.2 Output

Return Value for this function is a buffer formatted as shown in the table below.

Table 9.34: ARS Error Inject Clear - Output Format

Field	Byte Length	Byte Offset	Description
Status	2	0	Bytes[1-0] 0 - Success 1 - Not Supported. The ARS Error Inject Clear method is not supported by the platform. 2 - Invalid Input Parameters. Platform reports that the SPA range parameters passed to the ARS Error Inject method are invalid or the specified range does not have an injected error.
Extended Status	2	2	Reserved

9.19.7.11 Function Index 9 - ARS Error Inject Status Query

The maximum buffer size returned by the ARS Error Inject Status Query function is the same as the Max Query ARS Status Output Buffer Size reported by the Query ARS Capabilities function.

This ARS Error Inject Status Query allows the OSPM to list the currently active injected errors in the persistent memory ranges presented in the output buffer payload.

9.19.7.11.1 Input (Arg3)

None.

9.19.7.11.2 Output

Return Value for this function is a buffer, formatted as shown below.

Table 9.35: ARS Error Inject Status Query - Output Format

Field	Byte Length	Byte Offset	Description
Status	2	0	Bytes[1-0] 0 - Success. 1 - Not Supported. The ARS Error Inject Status Query method is not supported by the platform.
Extended Status	2	2	Reserved
Injected Error Record Count	4	4	Number of Error Records in the following array of Error Records. If no ARS injected error, the Injected Error Count field is 0.
ARS Error Inject Status Query Error Records	Varies	8	See the next table below for the format of the ARS Error Inject Status Query Error Record.

Table 9.36: ARS Error Inject Status Query - Error Record Format

Field	Byte Length	Byte Offset	Description
ARS Error Inject Status Query Error Record SPA Range Base	8	0	Starting SPA range of an injected error.
ARS Error Inject Status Query Error Record SPA Range Length	8	8	Length in bytes of the injected error starting at the SPA range.

9.19.7.12 Function Index 0xA - Query ARS Error Inject Capabilities

Query ARS Error Inject Capabilities is used by software to detect the system platforms capabilities related to injecting ARS errors.

9.19.7.12.1 Function Input (Arg3)

None.

9.19.7.12.2 Function Output

Table 9.37: ARS Error Inject Options Support

Field	Byte Length	Byte Offset	Description
Status	2	0	Defined in <i>NVDIMM Root Device Function Index</i>
Extended Status	2	2	Reserved
Platform Support	4	4	Bit 0: Injected ARS Error Persistence. This bit only applies if Bit 2 of the ARS Error Inject Options Support, Persistent Error Support, is 0. If set to 1, all injected ARS errors persist across reboots and the OSPM must explicitly clear them. These are uncorrectable errors injected to specified memory locations. If set to 0, all injected ARS errors are cleared on reboot. Bits 31-1: Reserved
ARS Error Inject Options Support	1	8	Bit 0: Unconsumed Uncorrectable Memory Error Detected Notification Support. If set to 1, indicates system platform supports Bit 0 in the ARS Error Inject Options field in the ARS Error Inject input structure. Bit 1: Force Overflow Support. If set to 1, indicates system platform supports Bit 1 in the ARS Error Inject Options field in the ARS Error Inject input structure. Bit 2: Persistent Error Support. If set to 1, indicates system platform supports Bit 2 in the ARS Error Inject Options field in the ARS Error Inject input structure. Bits 7-3: Reserved

9.19.8 NVDIMM Device Methods

The return status codes for NVDIMM device methods is described in the following table.

Table 9.38: NVDIMM Device Method Return Status Code

Field	Byte Length	Byte Offset	Description
Status	2	0	0 - Success 1 - Not Implemented 2 - Invalid Input Parameters 3 - Hardware Error 4 - Retry Suggested 5 - Error - Unknown Reason 6 - Method Specific Error Code 7 - FFFFh Reserved
Extended Status	2	2	Method Specific

9.19.8.1 _NCH (Get NVDIMM Current Health Information)

This method provides current health information of the NVDIMM device. The platform notifies OSPM by NVDIMM Device NFIT Health Event Notification (see Table 5.196) whenever anything happens that can impact health of NVDIMM device (see Table 9.39). When OSPM receives the notification, it can get the current health information by calling this method. Regardless of health notification, OSPM can call this method at any time to get the current health of the NVDIMM device.

During boot time, the OSPM can call this method to get the current health of NVDIMM device and take appropriate action. During OSPM runtime, if a health problem gets corrected then also the platform shall notify OSPM by the NVDIMM Device NFIT Health Event Notification.

Arguments:

None

Return Value:

A buffer containing the current health information as described below

Return Value Information:

Table 9.39: NCH Return Value

Field	Byte Length	Byte Offset	Description
Status	2	0	See <i>NVDIMM Device Method Return Status Code</i>
Extended Status	2	2	Reserved
Validation Flags	2	4	Bit [0] - Set to 1 to indicate that the Overall Health Status Flags field is valid. This bit is set to 1. Bit [1] - Set to 1 to indicate that the Overall Health Status Attributes field is valid. Bit [2-15] - Reserved

continues on next page

Table 9.39 – continued from previous page

Field	Byte Length	Byte Off-set	Description
Overall Health Status Flags	4	6	<p>Multiple bits may be set as appropriate. A bit set to 0 means the respective health problem does not exist or the bit is not applicable to the NVDIMM. If all bits are 0, the NVDIMM is healthy.</p> <p>Bit [0] - MAINTENANCE NEEDED. This bit is set to 1 to indicate that maintenance is required - e.g. temperature alarm tripped, energy source lifetime alarm tripped.</p> <p>Bit [1] - PERFORMANCE DEGRADED. This bit is set to 1 to indicate that performance is degraded.</p> <p>Bits [2-7] - Reserved Following bits indicate situations where the OSPM should assume write persistency loss but reads still function properly.</p> <p>Bit [8] - WRITE PERSISTENCY LOSS IN EVENT OF POWER LOSS. This bit is set to 1 to indicate that the OSPM should assume that all the writes since last time the NVDIMM was brought online may be lost in event of power loss.</p> <p>Bit [9] - WRITE PERSISTENCY LOSS IN EVENT OF OFFLINE. This bit is set to 1 to indicate that the OSPM should assume that all the writes since last time the NVDIMM was brought online may be lost when any subsequent offline operation is attempted.</p> <p>Bit [10] - WRITE PERSISTENCY LOSS IMMINENT. This bit is set to 1 to indicate that the OSPM should assume that subsequent writes may not persist.</p> <p>Bit [11-15] - Reserved The following bits indicate situations where the OSPM should assume all data loss.</p> <p>Bit [16] - ALL DATA LOSS IN THE EVENT OF POWER LOSS. This bit is set to 1 to indicate that the OSPM should assume that all data may be lost in the event of power loss.</p> <p>Bit [17] - ALL DATA LOSS IN THE EVENT OF OFFLINE. This bit is set to 1 to indicate that the OSPM should assume that all data may be lost when any subsequent offline operation is attempted.</p> <p>Bit [18] - ALL DATA LOSS IMMINENT. This bit is set to 1 to indicate that the OSPM should assume that subsequent reads may fail or return invalid data and subsequent writes may not persist.</p> <p>Bit [19-31] - Reserved</p>
Overall Health Status Attributes	4	10	<p>Bit [0] - PERMANENT HEALTH CONDITION - This bit is set to 1 to indicate that the health problem(s) reported in Overall Health Status Flags are permanent. If all the bits of Overall Health Status Flags are 0's, then NVDIMM is healthy and this bit shall be ignored by OSPM.</p> <p>Bit [1-31] - Reserved</p>
Reserved	50	14	Reserved

Note: These fields do not track data loss during the previous shutdown or any failures during boot time. If the condition that caused those failures still exists when _NCH method is called, then platform shall reflect appropriately in the fields of this method.

9.19.8.2 **_NBS (Get NVDIMM Boot Status)**

This method provides information about NVDIMM device’s status at boot time. The information provided by this method is updated by the platform during boot and remains unchanged during runtime.

Arguments:

None

Return Value:

A buffer containing device boot status information as described below

Return Value Information:

Table 9.40: **_NBS Return Value**

Field	Byte Length	Byte Offset	Description
Status	2	0	See Table 9.38
Extended Status	2	2	Reserved
Validation Flags	2	4	Bit [0] - Set to 1 to indicate that Data Loss Count field is valid. This bit is set to 1. Bit [1-15] - Reserved
Data Loss Count	4	6	A monotonically increasing counter which is incremented whenever the NVDIMM device fails to save and/or flush data to the persistent media. This also includes any data corruption or loss which is not signaled to the OSPM by any other architected means. This counter is intended for the OSPM to compare against one previously saved by the OSPM in determining the possibility of catastrophic data loss. For example, since data loss counter is monotonically increasing, OSPM can detect data loss if another OSPM was booted on the machine between the shutdown and boot of the original OSPM.
Reserved	54	10	Reserved

9.19.8.3 **_NIC (Get NVDIMM Health Error Injection Capabilities)**

This method reports health error injection capabilities that are supported by the platform. The health errors mentioned in table 9-320 are same as those mentioned in the *_NCH method*.

Arguments:

None

Return Value:

See Table 9.41 below.

Table 9.41: **_NIC Output Buffer**

Field	Byte Length	Byte Offset	Description
Status	2	0	See Table 9.38
Extended Status	2	2	Reserved

continues on next page

Table 9.41 – continued from previous page

Field	Byte Length	Byte Offset	Description
Health Error Injection Capabilities	4	4	<p>A bit is set to 1 if the respective health error injection is supported, otherwise the bit is set to 0:</p> <p>Bit [0] - MAINTENANCE NEEDED</p> <p>Bit [1] - PERFORMANCE DEGRADED</p> <p>Bits [2-7] - Reserved</p> <p>Bit [8] - WRITE PERSISTENCY LOSS IN EVENT OF POWER LOSS</p> <p>Bit [9] - WRITE PERSISTENCY LOSS IN EVENT OF OFFLINE</p> <p>Bit [10] - WRITE PERSISTENCY LOSS IMMINENT</p> <p>Bit [11-15] - Reserved</p> <p>Bit [16] - ALL DATA LOSS IN THE EVENT OF POWER LOSS</p> <p>Bit [17] - ALL DATA LOSS IN THE EVENT OF OFFLINE</p> <p>Bit [18] - ALL DATA LOSS IMMINENT</p> <p>Bits [19-31] - Reserved</p>
Overall Health Status Attributes Capabilities	4	8	<p>Bit [0] - PERMANENT HEALTH CONDITION. This bit is set to 1 if permanent health errors can be injected, otherwise the bit is set to 0.</p> <p>Bit [1-31] - Reserved</p>
Reserved	52	12	

9.19.8.4 _NIH (NVDIMM Inject/Clear Health Errors)

This method has two modes: Inject mode and Clear mode. The OSPM should use this method for health error injection only after verifying that the NVDIMM device has no real health errors.

In Inject mode, the OSPM can request the platform to:

- inject one or more health errors
- set one or more “Overall Health Status Attributes”

The OSPM can request either or both the items mentioned above in a single call. Unless errors are cleared, the platform shall accumulate the injected errors and attributes through subsequent calls of this method.

If a platform can inject at least one error or set at least one attribute, then the platform shall send NVDIMM Device Health Event Notification if supported (see [Table 5.196](#)). The OSPM can call `_NCH` (see [Table 9.39](#)) and the platform shall report the currently injected errors and attributes in the return buffer.

If a platform can inject only a subset of OSPM requested errors or set only a subset of OSPM requested attributes, then the platform shall return an output buffer with Status set to 6 (see [Table 9.38](#)) and Extended Status set to 1 (see [Table 9.43](#)). At that time, the OSPM can call the `_NIG` method (see [Section 9.19.8.5](#)) to get currently injected errors. If the OSPM requests to inject errors which is already injected, then the platform shall return Success. If the OSPM requests to inject an error or set an attribute which is not supported by method `_NIC`, then that method shall return output buffer with Status set to 2 (see [Table 9.38](#)).

The impact of the injected errors on fields reported by the method `_NCH`, NVDIMM State Flags of NVDIMM Region Mapping Structure (see [Section 5.2.26.3](#)) and on fields reported by NVDIMM device method `_NBS` (see [Section 9.19.8.2](#)) after a reset is implementation specific.

In Clear mode, the OSPM can request the platform to:

- clear one or more currently injected errors
- clear one or more “Overall Health Status Attributes” of currently injected error(s)
- The OSPM can request either or both the items mentioned above in a single call.

If a platform can clear at least one error or one attribute, then it shall send NVDIMM Device Health Event Notification (see Table 5.196) if supported. The OSPM can call `_NCH` (see Table 9.39) and the platform shall report any remaining injected errors and the attributes in the return buffer.

If a platform can clear only a subset of OSPM requested errors and attributes, then the platform shall return an output buffer with Status set to 6 (see Table 9.38) and Extended Status set to 1 (see: numref: nih-output-buffer). At that time, the OSPM can call `_NIG` method (see Section 9.19.8.5) to get currently injected errors. If the OSPM requests to clear error(s) which are not currently injected or requests to clear attribute(s) which are not currently set, then the platform shall return Success. If the OSPM requests to clear an error or clear an attribute which is not supported by method `_NIC`, then this method shall return output buffer with Status set to 2 (see Table 9.38).

One implementation of the health error injection is to emulate at firmware level without injecting any errors in real hardware.

Arguments:

Table 9.42: `_NIH` Input Buffer

Field	Byte Length	Byte Offset	Description
Mode	1	0	0 - Reserved 1 - Inject error(s) 2 - Clear error(s) 3 - 255 - Reserved
Reserved	3	1	Reserved
Overall Health Status Errors	4	4	These bits are used to inject/clear health error(s) reported by <code>_NIC</code> method (see Section 9.19.8.4). If Mode is set to 1, a bit is set to 1 to inject the respective error. OSPM can set one or more error bits to 1. If Mode is set to 2, a bit is set to 1 to clear the respective error. OSPM can set one or more error bits to 1 (see below). Bit [0] - MAINTENANCE NEEDED Bit [1] - PERFORMANCE DEGRADED Bit [2-7] - Reserved Bit [8] - WRITE PERSISTENCY LOSS IN EVENT OF POWER LOSS Bit [9] - WRITE PERSISTENCY LOSS IN EVENT OF OFFLINE Bit [10] - WRITE PERSISTENCY LOSS IMMINENT Bit [11-15] - Reserved Bit [16] - ALL DATA LOSS IN THE EVENT OF POWER LOSS Bit [17] - ALL DATA LOSS IN THE EVENT OF OFFLINE Bit [18] - ALL DATA LOSS IMMINENT Bit [19-31] - Reserved

continues on next page

Table 9.42 – continued from previous page

Field	Byte Length	Byte Offset	Description
Overall Health Status Attributes	4	8	Bit [0] - PERMANENT HEALTH CONDITION. If Mode is set to 1, this bit is set to 1 to inject health errors as permanent errors, otherwise the bit is set to 0. If Mode is set to 2, this bit is set to 1 to clear the “Permanent Health Condition” of the injected errors. Bit [1-31] - Reserved
Reserved	52	12	Reserved

Return Value:

Table 9.43: **_NIH Output Buffer**

Field	Byte Length	Byte Offset	Description
Status	2	0	Set :ref: <i>nvdimm-device-method-return-status-code</i>
Extended Status	2	2	0 - Reserved 1 - If Mode is 1, only a subset of requested errors is injected or only a subset of requested attributes is set. If Mode is 2, only a subset of requested errors is cleared or only a subset of requested attributes is cleared. 2 - FFFFh Reserved

9.19.8.5 **_NIG (Get NVDIMM Inject Health Error Status)**

This method reports currently active health errors and their error attributes that are injected by NVDIMM device method `_NIH`.

Arguments:

None

Return Value:

Table 9.44: **_NIG Output Buffer**

Field	Byte Length	Byte Offset	Description
Status	2	0	See <i>NVDIMM Device Method Return Status Code</i>
Extended Status	2	2	Reserved
Validation Flags	2	4	Bit [0] - Set to 1 to indicate that the Injected Overall Health Status Flags field is valid. This bit is set to 1. Bit [1] - Set to 1 to indicate that the <i>Overall Health Status Attributes of Injected Errors</i> field is valid. Bit [2-15] - Reserved

continues on next page

Table 9.44 – continued from previous page

Field	Byte Length	Byte Offset	Description
Injected Overall Health Status Errors	4	6	<p>If a bit is set to 1 then the respective error is currently injected:</p> <p>Bit [0] - MAINTENANCE NEEDED</p> <p>Bit [1] - PERFORMANCE DEGRADED</p> <p>Bit [2-7] - Reserved</p> <p>Bit [8] - WRITE PERSISTENCY LOSS IN EVENT OF POWER LOSS</p> <p>Bit [9] - WRITE PERSISTENCY LOSS IN EVENT OF OFFLINE</p> <p>Bit [10] - WRITE PERSISTENCY LOSS IMMINENT</p> <p>Bit [11-15] - Reserved</p> <p>Bit [16] - ALL DATA LOSS IN THE EVENT OF POWER LOSS</p> <p>Bit [17] - ALL DATA LOSS IN THE EVENT OF OFFLINE</p> <p>Bit [18] - ALL DATA LOSS IMMINENT</p> <p>Bit [19-31] - Reserved</p>
Overall Health Status Attributes of Injected Errors	4	10	<p>Bit [0] - PERMANENT HEALTH CONDITION. This bit is set to 1 to indicate that the injected error(s) are permanent health error(s), otherwise the bit is set to 0.</p> <p>Bit [1-31] - Reserved</p>
Reserved	50	14	Reserved

POWER SOURCE AND POWER METER DEVICES

This section specifies the battery, AC adapter, and power source device objects OSPM uses to manage power resources, as well as the power meter device objects OSPM uses to measure power consumption.

A battery device is required to either have a Smart Battery subsystem or a Control Method Battery interface as described in this section. OSPM is required to be able to connect and manage a battery on either of these interfaces. This section describes these interfaces.

In the case of a compatible ACPI Smart Battery Table, the Definition Block needs to include a Bus/Device package for the SMB-HC. This will install an OS-specific driver for the SMBus, which in turn will locate the components of the Smart Battery subsystem. In addition to the battery or batteries, the Smart Battery subsystem includes a charger and a manager device to handle subsystems with multiple batteries.

The Smart Battery System Manager is one implementation of a manager device that is capable of arbitrating among the available power sources (AC power and batteries) for a system. It provides a superset of the Smart Battery Selector functionality, such as safely responding to power events (AC versus battery power), inserting and removing batteries and notifying the OS of all such changes. Additionally, the Smart Battery System Manager is capable of handling configurations including simultaneous charging and discharging of multiple batteries. Unlike the Smart Battery Selector that shares responsibility for configuring the battery system with OSPM, the Smart Battery System Manager alone controls the safe configuration of the battery system and simply issues status changes to OSPM when the configuration changes. Smart Battery System Manager is the recommended solution for handling multiple-battery systems.

A Power Meter device is the logical representation of a platform sensor that measures the power consumption of one or more devices in the system. A basic platform implementation implements interfaces that query the current power consumption and get the currently configured power consumption hardware limit, while more advance power meter device implementations provide interfaces that support OSPM configurable power consumption trip points that trigger SCI events, or enable configuration of the underlying hardware to enforce a hard limit on the maximum amount of power that can be consumed.

10.1 Smart Battery Subsystems

The Smart Battery subsystem is defined by the:

- System Management Bus Specification (SMBS)
- Smart Battery Data Specification (SBDS)
- Smart Battery Charger Specification (SBCS)
- Smart Battery System Manager Specification (SBSM)
- Smart Battery Selector Specification (SBSS)

An ACPI-compatible Smart Battery subsystem consists of:

- An SMB-HC (CPU to SMB-HC) interface

- At least one Smart Battery
- A Smart Battery Charger
- Either a Smart Battery System Manager or a Smart Battery Selector if more than one Smart Battery is supported

In such a subsystem, a standard way of communicating with a Smart Battery and Smart Battery Charger is through the SMBus physical protocols. The Smart Battery System Manager or Smart Battery Selector provides event notification (battery insertion/removal, and so on) and charger SMBus routing capability for any Smart Battery subsystem. A typical Smart Battery subsystem is illustrated below:

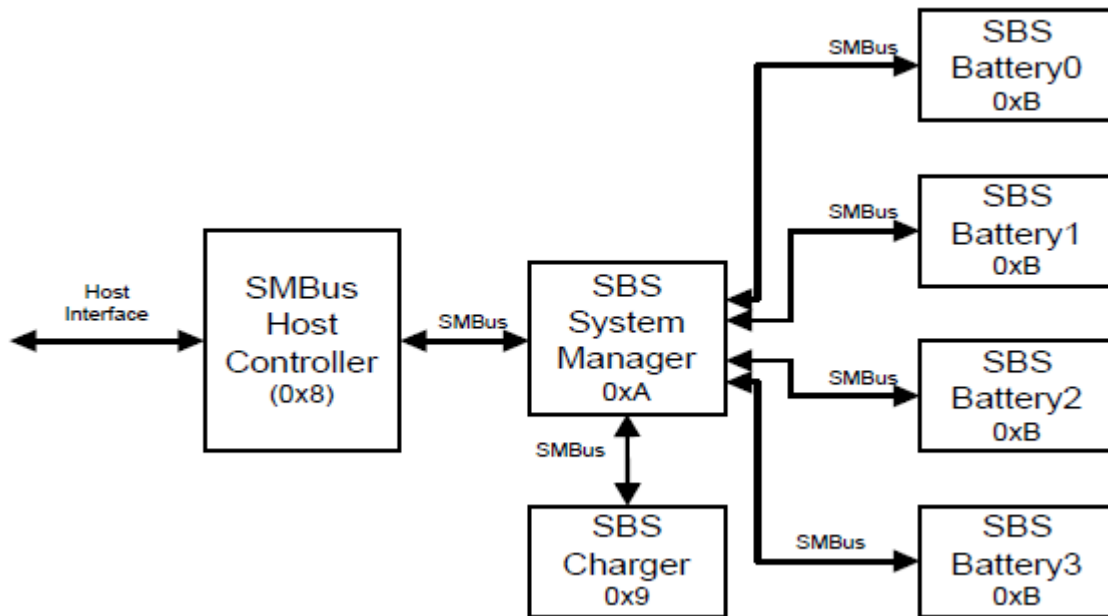

Fig. 10.1: Typical Smart Battery Subsystem (SBS)

SMBus defines a fixed 7-bit slave address per device. This means that all batteries in the system have the same address (defined to be 0xB). The slave addresses associated with Smart Battery subsystem components are shown in the following table.

Table 10.1: Example SMBus Device Slave Addresses

SMBus Device Description	SMBus Slave Address (A0-A6)
SMBus Host Slave Interface	0x8
Smart Battery Charger/Charger Selector or Charger System Manager	0x9
Smart Battery System Manager or Smart Battery Selector	0xA
Smart Battery	0xB

Each SMBus device has up to 256 registers that are addressed through the SMBus protocol's Command value. SMBus devices are addressed by providing the slave address with the desired register's Command value. Each SMBus register can have non-linear registers; that is, command register 1 can have a 32-byte string, while command register 2 can have a byte, and command register 3 can have a word.

The SMBus host slave interface provides a standard mechanism for the host CPU to generate SMBus protocol commands that are required to communicate with SMBus devices (in other words, the Smart Battery components). ACPI defines such an SMB-HC that resides in embedded controller address space; however, an OS can support any SMB-HC that has a native SMB-HC device driver.

- Event notification for battery insertion and removal

- Event notification for AC power connected or disconnected
- Status of which Smart Battery is communicating with the SMB-HC
- Status of which Smart Battery(s) are powering the system
- Status of which Smart Battery(s) are connected to the charger
- Status of which Smart Batteries are present in the system
- Event notification when the Smart Battery System Manager switches from one power source to another
- Hardware-switching to an alternate Smart Battery when the Smart Battery supplying power runs low
- Hardware switching between battery-powered and AC-powered powered operation

The Smart Battery System Manager function can reside in a standalone SMBus slave device (Smart Battery System Manager that responds to the 0xA slave address), may be present within a smart charger device (Smart Battery Charger that responds to the 0x9 slave address), or may be combined within the embedded controller (that responds to the 0xA slave address). If both a Smart Battery Charger and a standalone Smart Battery System Manager are present in the same Smart Battery subsystem, then the driver assumes that the standalone Smart Battery System Manager is wired to the batteries.

The Smart Battery charger is an SMBus device that provides a standard programming model to control the charging of Smart Batteries present in a Smart Battery subsystem. For single battery systems, the Smart Battery Charger is also responsible for notifying the system of the battery and AC status.

The Smart Battery provides intelligent chemistry-independent power to the system. The Smart Battery is capable of informing the Smart Battery charger of its charging requirements (which provides chemistry independence) and providing battery status and alarm features needed for platform battery management.

10.1.1 ACPI Smart Battery Status Change Notification Requirements

The Smart Battery System Manager, the Smart Battery Selector, and the Smart Battery Charger each have an optional mechanism for notifying the system that the battery configuration or AC status has changed. ACPI requires that this interrupt mechanism be through the SMBus Alarm Notify mechanism.

For systems using an embedded controller as the SMBus host, a battery system device issues a status change notification by either mastering the SMBus to send the notification directly to the SMBus host, or by emulating it in the embedded controller. In either case, the process is the same. After the notification is received or emulated, the embedded controller asserts an SCI. The source of the SCI is identified by a GPE that indicates the SCI was caused by the embedded controller. The embedded controller's status register alarm bit is set, indicating that the SMBus host received an alarm message. The Alarm Address Register contains the address of the SMBus device that originated the alarm and the Alarm Data Registers contain the contents of that device's status register.

10.1.1.1 Smart Battery Charger

This requires a Smart Battery Charger, on a battery or AC status change, to generate an SMBus Alarm Notify. The contents of the Smart Battery Charger's ChargerStatus() command register (0x13) is placed in the embedded controller's Alarm Data Registers, the Smart Battery Charger's slave address (*See Note Below*) (0x09) is placed in the embedded controller's Alarm Address Register and the EC's Status Register's Alarm bit is set. The embedded controller then asserts an SCI.

Note: The 1.0 SMBus protocol specification is ambiguous about the definition of the "slave address" written into the command field of the host controller. In this case, the slave address is actually the combination of the 7-bit slave address and the Write protocol bit. Therefore, bit 0 of the initiating device's slave address is aligned to bit 1 of the

host controller's slave command register, bit 1 of the slave address is aligned to bit 2 of the controller's slave command register, and so on.

10.1.1.2 Smart Battery Charger with optional System Manager or Selector

A Smart Battery Charger that contains the optional System Manager or Selector function (as indicated by the ChargerSpecInfo() command register, 0x11, bit 4) is required to generate an SMBus Alarm Notify on a battery or AC status change. The content of the Smart Battery Charger with an optional System Manager, the BatterySystemState() command register (0x21) (or in the case of an optional Selector, the SelectorState() (0x01)), is placed in the EC's Alarm Data Registers, the Smart Battery Charger's slave address (0x09) is placed in the embedded controller's Alarm Address Register, and the embedded controller's Status Register's Alarm bit is set. The embedded controller then asserts an SCI.

10.1.1.3 Smart Battery System Manager

The Smart Battery System Manager is required to generate an SMBus Alarm Notify on a battery or AC status change. The content of the Smart Battery System Manager's BatterySystemState() command register (0x01) is placed in the EC's Alarm Data Registers, the Smart Battery System Manager's slave address (0x0A) is placed in the EC's Alarm Address Register, and the embedded controller's Status Register's Alarm bit is set. The embedded controller then asserts an SCI.

10.1.1.4 Smart Battery Selector

The requirements for the Smart Battery Selector are the same as the requirements for the Smart Battery System Manager, with the exception that the contents of the SelectorState() command register (0x01) are used instead of BatterySystemState(). The Smart Battery Selector is a subset of the Smart Battery System Manager and does not have the added support for simultaneous charge/discharge of multiple batteries. The System Manager is the preferred implementation.

10.1.2 Smart Battery Objects

The Smart Battery subsystem requires a number of objects to define its interface. These are summarized below:

Table 10.2: Smart Battery Objects

Object	Description
_HID	This is the hardware ID named object that contains a string. For Smart Battery subsystems, this object returns the value of "ACPI0002." This identifies the Smart Battery subsystem to the Smart Battery driver.
_SBS	This is the Smart Battery named object that contains a DWORD. This named object returns the configuration of the Smart Battery.

10.1.3 _SBS (Smart Battery Subsystem)

The _SBS control method returns the configuration of the Smart Battery subsystem. This named object returns a DWORD value with a number from 0 to 4. If the number of batteries is greater than 0, then the Smart Battery driver assumes that a Smart Battery System Manager or Smart Battery Selector is present. If 0, then the Smart Battery driver assumes a single Smart Battery and neither a Smart Battery System Manager nor Smart Battery Selector is present.

Arguments:

None

Return Value:

The DWORD returned by _SBS is an Integer containing the Smart Battery subsystem configuration:

- 0 - Maximum of one Smart Battery and no Smart Battery System Manager or Smart Battery Selector.
- 1 - Maximum of one Smart Battery and a Smart Battery System Manager or Smart Battery Selector.
- 2 - Maximum of two Smart Batteries and a Smart Battery System Manager or Smart Battery Selector.
- 3 - Maximum of three Smart Batteries and a Smart Battery System Manager or Smart Battery Selector.
- 4 - Maximum of four Smart Batteries and a Smart Battery System Manager or Smart Battery Selector.

The maximum number of batteries is for the entire system. Therefore, if the platform is capable of supporting four batteries, but only two are normally present in the system, then this field should return 4. Notice that a value of 0 indicates a maximum support of one battery and there is no Smart Battery System Manager or Smart Battery Selector present in the system

As the SMBus is not an enumerable bus, all devices on the bus must be declared in the ACPI name-space. As the Smart Battery driver understands Smart Battery, Smart Battery Charger, and Smart Battery System Manager or Smart Battery Selector; only a single device needs to be declared per Smart Battery subsystem. The driver gets information about the subsystem through the hardware ID (which defines a Smart Battery subsystem) and the number of Smart Batteries supported on this subsystem (_SBS named object). The ACPI Smart Battery table indicates the energy levels of the platform at which the system should warn the user and then enter a sleeping state. The Smart Battery driver then reflects these as threshold alarms for the Smart Batteries.

A Smart Battery device declaration in the ACPI namespace requires the _GLK object if potentially contentious accesses to device resources are performed by non-OS code. See *_GLK (Global Lock)* for details about the _GLK object.

10.1.3.1 Example: Single Smart Battery Subsystem

This section illustrates how to define a Smart Battery subsystem containing a single Smart Battery and charger. The platform implementation is illustrated below:

In this example, the platform is using an SMB-HC that resides within the embedded controller and meets the ACPI standard for an embedded controller interface and SMB-HC interface. The embedded controller interface sits at system I/O port addresses 0x62 and 0x66. The SMB-HC is at base address 0x80 within embedded controller address space (as defined by the ACPI embedded controller specification) and responds to events on query value 0x30.

In this example the Smart Battery subsystem only supports a single Smart Battery. The ASL code for describing this interface is shown below:

```
Device (EC0) {
    Name (_HID, EISAID("PNP0C09"))
    Name (_CRS,
        ResourceTemplate () {
            IO (Decode16, 0x62, 0x62, 0, 1), // port 0x62 and 0x66
        }
    )
}
```

(continues on next page)

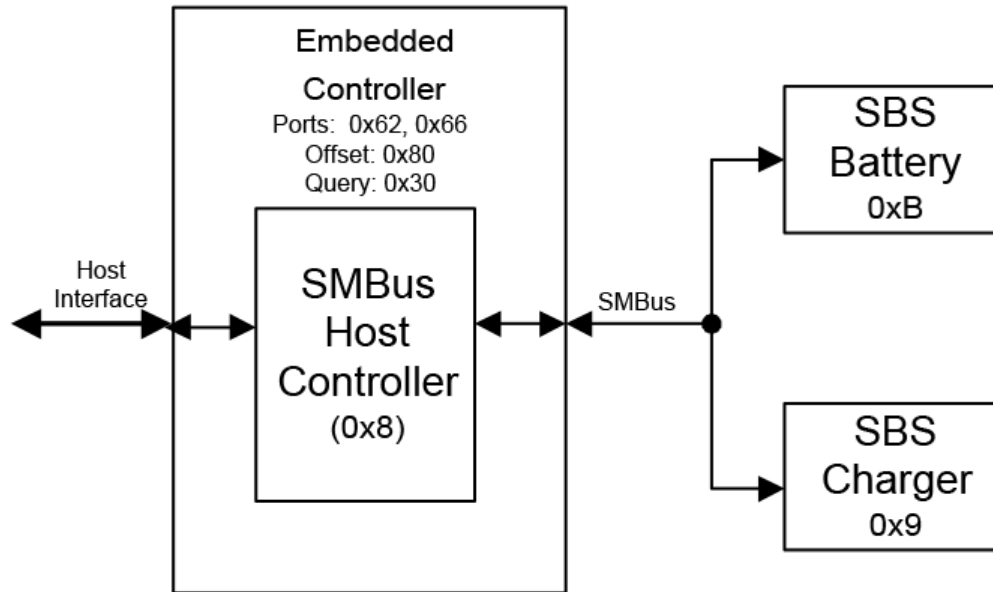

Fig. 10.2: Single Smart Battery Subsystem

(continued from previous page)

```

        IO (Decode16, 0x66, 0x66, 0, 1)
    }
)
Name (_GPE, 0)
Device (SMB0) {
    Name (_HID, "ACPI0001")           // Smart Battery Host Controller
    Name (_EC, 0x8030)               // EC offset (0x80), Query (0x30)
    Device (SBS0) {                  // Smart Battery Subsystem
        Name (_HID, "ACPI0002")      // Smart Battery Subsystem ID
        Name (_SBS, 0x1)            // Indicates support for one battery
    }
    // end of SBS0
}
// end of SMB0
}
// end of EC

```

10.1.3.2 Multiple Smart Battery Subsystem: Example

This section illustrates how to define a Smart Battery subsystem that contains three Smart Batteries, a Smart Battery System Manager, and a Smart Battery Charger. The platform implementation is illustrated below:

In this example, the platform is using an SMB-HC that resides within the embedded controller and meets the ACPI standard for an embedded controller interface and SMB-HC interface. The embedded controller interface sits at system I/O port addresses 0x100 and 0x101. The SMB-HC resides at base address 0x90 within embedded controller address space (as defined by the ACPI embedded controller specification) and responds to events on query value 0x31.

In this example the Smart Battery subsystem supports three Smart Batteries. The Smart Battery Charger and Smart Battery System Manager reside within the embedded controller, meet the Smart Battery System Manager and Smart Battery Charger interface specification, and respond to their 7-bit addresses (0xA and 0x9 respectively). The ASL code for describing this interface is shown below:

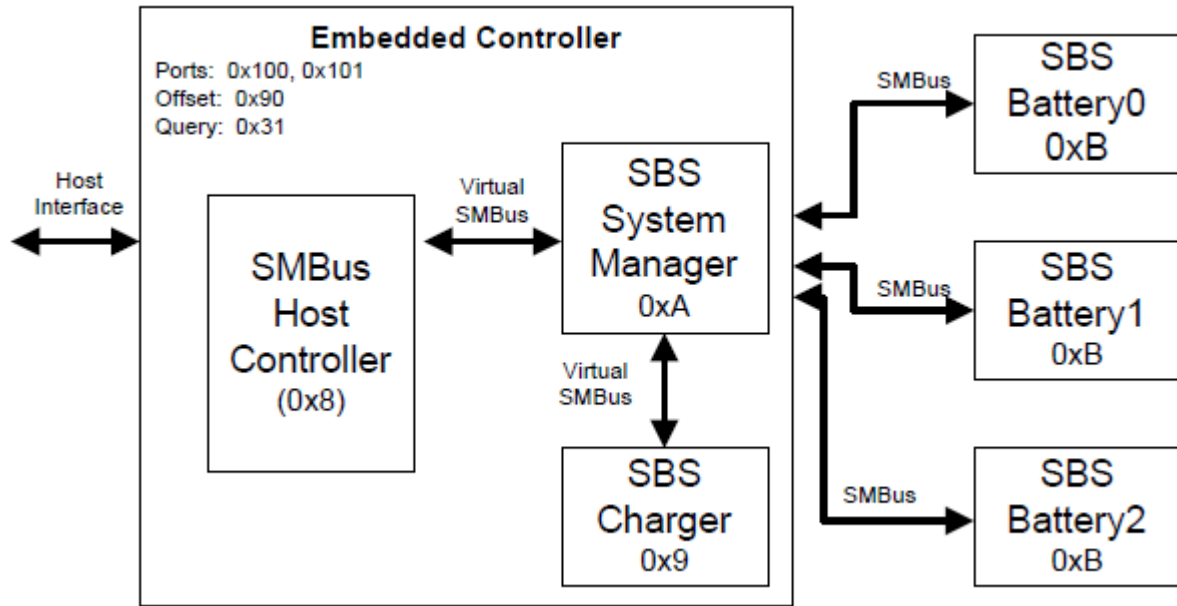

Fig. 10.3: Smart Battery Subsystem

```

Device (EC1) {
Name (_HID, EISAID("PNP0C09"))
    Name (_CRS,
        ResourceTemplate () {
            // port 0x100 and 0x101
            IO(Decode16, 0x100, 0x100, 0, 2)
        }
    )
    Name (_GPE, 1)
    Device (SMB1) {
        Name (_HID, "ACPI0001")
        Name (_EC, 0x9031)
        Device (SBS1){
            Name (_HID, "ACPI0002")
            Name (_SBS, 0x3)
        }
    }
}
    // Smart Battery Host Controller
    // EC offset (0x90), Query (0x31)
    // Smart Battery Subsystem
    // Smart Battery Subsystem ID
    // Indicates support for three batteries
    // end of SBS1
    // end of SMB1
    // end of EC
    
```

10.2 Control Method Batteries

The following section illustrates the operation and definition of the Control Method Battery.

The Hardware ID for a Control Method Battery is **PNP0C0A**.

10.2.1 Battery Events

The AML code handling an SCI for a battery event notifies the system of which battery's status may have changed. The OS uses the `_BST` control method to determine the current status of the batteries and what action, if any, should be taken (for more information about the `_BST` control method, see *Battery Control Methods*). The typical action is to notify applications monitoring the battery status to provide the user with an up-to-date display of the system battery state. But in some cases, the action may involve generating an alert or even forcing a system into a sleeping state. In any case, any changes in battery status should generate an SCI in a timely manner to keep the system power state UI consistent with the actual state of the system battery (or batteries).

Unlike most other devices, when a battery is inserted or removed from the system, the device itself (the battery bay) is still considered to be present in the system. For most systems, the `_STA` for this device will always return a value with bits 0-3 set and will toggle bit 4 to indicate the actual presence of a battery (see [Section 7.2.4](#)). When this insertion or removal occurs, the AML code handler for this event should issue a `Notify(battery_device, 0x81)` to indicate that the static battery information has changed. For systems that have battery slots in a docking station or batteries that cannot be surprise-removed, it may be beneficial or necessary to indicate that the entire device has been removed. In this case, the standard methods and notifications described in *Device Insertion, Removal, and Status Objects* should be used.

When the present state of the battery has changed or when the trip point set by the `_BTP` control method is reached or crossed, the hardware will assert a general purpose event. The AML code handler for this event issues a `Notify(battery_device, 0x80)` on the battery device. This notification is also sent when the Status Flags returned from `_BMD` change.

In the case where the remaining battery capacity becomes critically low, the AML code handler issues a `Notify(battery_device, 0x80)` and reports the battery critical flag in the `_BST` object. The OS performs an emergency

shutdown. For a full description of the critical battery state, see *Low Battery Levels*.

Sometimes the value to be returned from `_BST` or `_BIF` will be temporarily unknown. In this case, the method may return the value `0xFFFFFFFF` as a placeholder. When the value becomes known, the appropriate notification (`0x80` for `_BST` or `0x81` for `BIF`) should be issued, in like manner to any other change in the data returned by these methods. This will cause OSPM to re-evaluate the method—obtaining the correct data value.

When one or more of the status flags returned by the `_BMD` control method change, AML code issues a `Notify(battery_device, 0x82)` on the battery device unless this change occurs during a call to `_BMC` and the value of the status flags in `_BMD` match the value passed in to `_BMC`. If the value of the status bits cannot be set to reflect the action requested by the executing `_BMC`, the AML code will issue this notification. For example, calling `_BMC` with bit 0 set to initiate a calibration cycle while AC power is not available will cause AML to issue a `Notify(battery_device, 0x82)`.

A user can program peak power delivery thresholds in the `_BPT` control method for each battery. When a threshold is crossed, the platform firmware such as the embedded controller will assert an SCI interrupt. The AML event handler for this interrupt issues a `Notify(<battery_device>, 0x83)` on the battery device.

10.2.2 Battery Control Methods

The Control Method Battery is a battery with an AML code interface between the battery and the host PC. The battery interface is completely accessed by AML code control methods, allowing the OEM to use any type of battery and any kind of communication interface supported by ACPI. OSPM requires accurate battery data to perform optimal power management policy and to provide the end user with a meaningful estimation of remaining battery life. As such, control methods that return battery information should calculate this information rather than return hard coded data.

A Control Method Battery is described as a device object. Each device object supporting the Control Method Battery interface contains the following additional control methods. When there are two or more batteries in the system, each battery will have an independent device object in the namespace.

Table 10.3: **Battery Control Methods**

Object	Description
<code>_BCT</code>	Returns battery estimated charging time.
<code>_BIF</code>	Returns static information about a battery (in other words, model number, serial number, design voltage, and so on).
<code>_BIX</code>	Returns extended static information about a battery (in other words, model number, serial number, design voltage, and so on).
<code>_BMA</code>	Sets the averaging interval of the battery capacity measurement, in milliseconds.
<code>_BMC</code>	Control calibration and charging.
<code>_BMD</code>	Returns battery information related to battery recalibration and charging control.
<code>_BMS</code>	Sets the sampling time of the battery capacity measurement, in milliseconds.
<code>_BPC</code>	Returns static variables that are associated with system power characteristics on the battery path and power threshold support settings.
<code>_BPS</code>	Returns the power delivery capabilities of the battery at the present time.
<code>_BPT</code>	Control method to set a Battery Power Threshold.
<code>_BST</code>	Returns the current battery status (in other words, dynamic information about the battery, such as whether the battery is currently charging or discharging, an estimate of the remaining battery capacity, and so on).
<code>_BTH</code>	Communicates battery thermal throttle limit set by battery thermal zone.
<code>_BTM</code>	Returns battery estimated runtime at the present average rate of drain, or the runtime at a specified rate.
<code>_BTP</code>	Sets the Battery Trip point, which generates an SCI when battery capacity reaches the specified point.

continues on next page

Table 10.3 – continued from previous page

Object	Description
_OSC	OSPM Capabilities conveyance for batteries.
_PCL	List of pointers to the device objects representing devices powered by the battery - see Section 10.3.2
_STA	Returns general status of the battery - see Section 6.3.7 .

A Control Method Battery device declaration in the ACPI namespace requires the `_GLK` object if potentially contentious accesses to device resources are performed by non-OS code. See *[_GLK \(Global Lock\)](#)* for details about the `_GLK` object.

10.2.2.1 `_BCT` (Battery Charge Time)

When the battery is charging, this optional object returns the estimated time from present to when it is charged to a given percentage of Last Full Charge Capacity.

Arguments:

Arg0 - ChargeLevel (Integer (DWORD)): The queried charge level in units of percent of Last Full Charge Capacity. For example: 96 refers to 96% of Last Full Charge Capacity. Valid values are 1 - 100 (0x00000001 - 0x00000064).

Return Value:

An Integer (DWORD) containing a result code as follows:

0x00000000 - Specified targeted charging capacity is smaller than the current remaining capacity or larger than 100% of Last Full Charge Capacity. 0x00000001 - 0xFFFFFFFFE - Estimated charging time in seconds 0xFFFFFFFF - Charging time is unknown

10.2.2.2 `_BIF` (Battery Information)

This object returns the static portion of the Control Method Battery information. This information remains constant until the battery is changed. This object is deprecated in ACPI 4.0. The `_BIX` object provides expanded battery information and includes all of the information provide by `_BIF`. See *[_BIX \(Battery Information Extended\)](#)*).

Arguments:

None

Return Value:

A Package containing the battery information as described below.

Return Value Information:

`_BIF` returns a package in the format shown below:

```
Package {
    Power Unit                // Integer (DWORD)
    Design Capacity           // Integer (DWORD)
    Last Full Charge Capacity // Integer (DWORD)
    Battery Technology        // Integer (DWORD)
    Design Voltage            // Integer (DWORD)
    Design Capacity of Warning // Integer (DWORD)
    Design Capacity of Low    // Integer (DWORD)
    Battery Capacity Granularity 1 // Integer (DWORD)
    Battery Capacity Granularity 2 // Integer (DWORD)
```

(continues on next page)

(continued from previous page)

```

Model Number          // String (ASCIIIZ)
Serial Number         // String (ASCIIIZ)
Battery Type          // String (ASCIIIZ)
OEM Information       // String (ASCIIIZ)
}
    
```

Table 10.4: BIF Return Package Values

Field	Format	Description
Power Unit	Integer (DWORD)	Indicates the units used by the battery to report its capacity and charge/discharge rate information to the OS. 0x00000000 - Capacity information is reported in [mWh] and charge/discharge rate information in [mW]. 0x00000001 - Capacity information is reported in [mAh] and charge/discharge rate information in [mA].
Design Capacity	Integer (DWORD)	Battery's design capacity. Design Capacity is the nominal capacity of a new battery. The Design Capacity value is expressed as power [mWh] or current [mAh] depending on the Power Unit value. 0x00000000 - 0x7FFFFFFF (in [mWh] or [mAh]) 0xFFFFFFFF - Unknown design capacity
Last Full Charge Capacity	Integer (DWORD)	Predicted battery capacity when fully charged. The Last Full Charge Capacity value is expressed as power (mWh) or current (mAh) depending on the Power Unit value. 0x00000000h - 0x7FFFFFFF (in [mWh] or [mAh]) 0xFFFFFFFF - Unknown last full charge capacity
Battery Technology	Integer (DWORD)	0x00000000 - Primary (for example, non-rechargeable) 0x00000001 - Secondary (for example, rechargeable)
Design Voltage	Integer (DWORD)	Nominal voltage of a new battery. 0x00000000 - 0x7FFFFFFF in [mV] 0xFFFFFFFF - Unknown design voltage
Design capacity of Warning	Integer (DWORD)	OEM-designed battery warning capacity. See <i>Low Battery Levels</i> 0x00000000 - 0x7FFFFFFF in [mWh] or [mAh]
Design Capacity of Low	Integer (DWORD)	OEM-designed low battery capacity. See <i>Low Battery Levels</i> 0x00000000 - 0x7FFFFFFF in [mWh] or [mAh]

continues on next page

Table 10.4 – continued from previous page

Field	Format	Description
Battery Capacity Granularity 1	Integer (DWORD)	Battery capacity granularity between low and warning in [mAh] or [mWh]. That is, this is the smallest increment in capacity that the battery is capable of measuring. See note below for more details
Battery Capacity Granularity 2	Integer (DWORD)	Battery capacity granularity between warning and Full in [mAh] or [mWh]. That is, this is the smallest increment in capacity that the battery is capable of measuring. This may be a different value than Battery Capacity Granularity 1 to accommodate systems where the granularity accuracy may change depending on the battery level. See note below for more details.
Model Number	String (ASCIIZ)	OEM-specific Control Method Battery model number
Serial Number	String (ASCIIZ)	OEM-specific Control Method Battery serial number
Battery Type	String (ASCIIZ)	The OEM-specific Control Method Battery type
OEM Information	String (ASCIIZ)	OEM-specific information for the battery that the UI uses to display the OEM information about the Battery. If the OEM does not support this information, this field should contain a NULL string.

Additional Notes:

- A secondary-type battery should report the corresponding capacity (except for Unknown).
- On a multiple-battery system, all batteries in the system should return the same granularity.
- Operating systems prefer these control methods to report data in terms of power (watts).
- On a multiple-battery system, all batteries in the system must use the same power unit.
- The definition of battery capacity granularity has been clarified. For OSPM to determine if systems support the clarified definition of battery capacity granularity, OSPM may evaluate an `_OSC` method at the battery scope to indicate support for this capability, and for the platform to indicate if it supports these extended capabilities.

10.2.2.3 _BIX (Battery Information Extended)

The `_BIX` object returns the static portion of the Control Method Battery information. This information remains constant until the battery is changed. The `_BIX` object returns all information available via the `_BIF` object plus additional battery information. The `_BIF` object is deprecated in lieu of `_BIX` in ACPI 4.0.

Arguments:

None

Return Value:

A Package containing the battery information as described below

Return Value Information:

`_BIX` returns a package in the format below.

```
Package {
    // ASCIIZ is ASCII character string terminated with a 0x00.
    Revision                //Integer
    Power Unit              //Integer (DWORD)
    Design Capacity         //Integer (DWORD)
    Last Full Charge Capacity //Integer (DWORD)
    Battery Technology      //Integer (DWORD)
```

(continues on next page)

(continued from previous page)

```

Design Voltage //Integer (DWORD)
Design Capacity of Warning //Integer (DWORD)
Design Capacity of Low //Integer (DWORD)
Cycle Count //Integer (DWORD)
Measurement Accuracy //Integer (DWORD)
Max Sampling Time //Integer (DWORD)
Min Sampling Time //Integer (DWORD)
Max Averaging Interval //Integer (DWORD)
Min Averaging Interval //Integer (DWORD)
Battery Capacity Granularity 1 //Integer (DWORD)
Battery Capacity Granularity 2 //Integer (DWORD)
Model Number //String (ASCII)
Serial Number //String (ASCII)
Battery Type //String (ASCII)
OEM Information //String (ASCII)
Battery Swapping Capability //Integer (DWORD)
}
    
```

Table 10.5: BIX Return Package Values

Field	Format	Description
Revision	Integer	Current revision is: 1
Power Unit	Integer (DWORD)	Indicates the units used by the battery to report its capacity and charge/discharge rate information to the OS. 0x00000000 - Capacity information is reported in [mWh] and charge/discharge rate information in [mW]. 0x00000001 - Capacity information is reported in [mAh] and charge/discharge rate information in [mA].
Design Capacity	Integer (DWORD)	Battery's design capacity. Design Capacity is the nominal capacity of a new battery. The Design Capacity value is expressed as power [mWh] or current [mAh] depending on the Power Unit value. 0x00000000 - 0x7FFFFFFF (in [mWh] or [mAh]) 0xFFFFFFFF - Unknown design capacity
Last Full Charge Capacity	Integer (DWORD)	Predicted battery capacity when fully charged. The Last Full Charge Capacity value is expressed as power (mWh) or current (mAh) depending on the Power Unit value. 0x00000000h - 0x7FFFFFFF (in [mWh] or [mAh]) 0xFFFFFFFF - Unknown last full charge capacity
Battery Technology	Integer (DWORD)	0x00000000 - Primary (for example, non-rechargeable) 0x00000001 - Secondary (for example, rechargeable)

continues on next page

Table 10.5 – continued from previous page

Field	Format	Description
Design Voltage	Integer (DWORD)	Nominal voltage of a new battery. 0x000000000 - 0x7FFFFFFF in [mV] 0xFFFFFFFF - Unknown design voltage
Design capacity of Warning	Integer (DWORD)	OEM-designed battery warning capacity. See <i>Low Battery Levels</i> 0x000000000 - 0x7FFFFFFF in [mWh] or [mAh]
Design Capacity of Low	Integer (DWORD)	OEM-designed low battery capacity. See <i>Low Battery Levels</i> 0x000000000 - 0x7FFFFFFF in [mWh] or [mAh]
Cycle Count	Integer (DWORD)	The number of cycles the battery has experienced. A cycle is defined as: An amount of discharge approximately equal to the value of Design Capacity. 0x000000000 - 0xFFFFFFFF 0xFFFFFFFF - Unknown cycle count
Measurement Accuracy	Integer (DWORD)	The accuracy of the battery capacity measurement, in thousandth of a percent. (0% - 100.000%) For example, The value 80000 would mean 80% accuracy.
Max Sampling Time	Integer (DWORD)	The sampling time is the duration between two consecutive measurements of the battery's capacities specified in <code>_BST</code> , such as present rate and remaining capacity. If the OSPM makes two succeeding readings through <code>_BST</code> beyond the duration, two different results will be returned. The Max Sampling Time is the maximum sampling time the battery can support, in milliseconds. 0xFFFFFFFF is returned if the information is unavailable.
Min Sampling Time	Integer (DWORD)	The Min Sampling Time is the minimum sampling time the battery can support, in milliseconds. 0xFFFFFFFF is returned if the information is unavailable.
Max Averaging Interval	Integer (DWORD)	The Average Interval is the length of time (in milliseconds) within which the battery averages the capacity measurements specified in <code>_BST</code> , such as remaining capacity and present rate. The Sampling time specifies the frequency of measurements, and the average interval specifies the width of the time window of every measurement. This field indicates the maximum Average Interval that the battery supports.
Min Averaging Interval	Integer (DWORD)	This field indicates the minimum Average Interval that the battery supports
Battery Capacity Granularity 1	Integer (DWORD)	Battery capacity granularity between low and warning in [mAh] or [mWh]. That is, this is the smallest increment in capacity that the battery is capable of measuring. See note below for more details

continues on next page

Table 10.5 – continued from previous page

Field	Format	Description
Battery Capacity Granularity 2	Integer (DWORD)	Battery capacity granularity between warning and Full in [mAh] or [mWh]. That is, this is the smallest increment in capacity that the battery is capable of measuring. This may be a different value than Battery Capacity Granularity 1 to accommodate systems where the granularity accuracy may change depending on the battery level. See note below for more details.
Model Number	String (ASCII)	OEM-specific Control Method Battery model number
Serial Number	String (ASCII)	OEM-specific Control Method Battery serial number
Battery Type	String (ASCII)	The OEM-specific Control Method Battery type
OEM Information	String (ASCII)	OEM-specific information for the battery that the UI uses to display the OEM information about the Battery. If the OEM does not support this information, this field should contain a NULL string.
Battery Swapping Capability	Integer (DWORD)	<p>0x00000000 Non swappable battery (for example, sealed internal battery not accessible to user)</p> <p>0x00000001 Cold swappable battery, i.e. batteries that require system to be shut down in order to replace the battery while on DC power (for example, phone and laptop batteries accessible to user)</p> <p>0x00000010 Hot swappable battery, i.e. batteries that do not require the system to be shut down in order to replace/remove the battery while on DC power (for example, accessory batteries, cd tray batteries, external batteries, dock batteries, keyboard batteries)</p>

Note: A secondary-type battery should report the corresponding capacity (except for Unknown).

On a multiple-battery system, all batteries in the system should return the same granularity.

Operating systems prefer these control methods to report data in terms of power (watts).

On a multiple-battery system, all batteries in the system must use the same power unit.

The definition of battery capacity granularity has been clarified. For OSPM to determine if systems support the clarified definition of battery capacity granularity, OSPM may evaluate an `_OSC` method at the battery scope to indicate support for this capability, and for the platform to indicate if it supports these extended capabilities.

10.2.2.4 `_BMA` (Battery Measurement Averaging Interval)

This object is used to set the averaging interval of the battery capacity measurement, in milliseconds. The Battery Measurement Averaging Interval is the length of time within which the battery averages the capacity measurements specified in `_BST`, such as remaining capacity and present rate.

The OSPM may read the Max Average Interval and Min Average Interval with `_BIX` during boot time, and set a specific average interval within the range with `_BMA`.

Arguments:(1)

Arg0 - AveragingInterval (Integer(DWORD)) the averaging interval of battery capacity measurement:

0x00000001 - 0xFFFFFFFF (in units of millisecond)

Return Value:

An Integer (DWORD) containing a result code as follows:

0x00000000 - Success.

0x00000001 - Failure to set Battery Measurement Averaging Interval because it is out of the battery's measurement capability.

0x00000002 - 0xFFFFFFFF - Reserved.

10.2.2.5 **_BMC (Battery Maintenance Control)**

This object is used to initiate calibration cycles or to control the charger and whether or not a battery is powering the system. This object is only present under a battery device if the `_BMD` Capabilities Flags field has bit 0, 1, 2, or 5 set.

Arguments:(1)

Arg0 - An Integer containing feature control flags:

Bit [0] - Set to initiate an AML controlled calibration cycle. Clear to end the calibration cycle

Bit [1] - Set to disable charging. Clear to enable charging

Bit [2] - Set to allow the battery to discharge while AC power is available. Clear to prevent discharging while AC power is available

Bit [3] – Set to request suspension of Battery Charge Limiting mode

Return Value:

None

See *Battery Calibration* for more information.

Evaluating this object with bit0 set will initiate an AML controlled recalibration cycle if `_BMD` indicates that this is supported. The calibration cycle is controlled by the platform and will typically include disabling the AC adapter and discharging the battery, then charging the battery. While the battery is charging, the platform runtime firmware should set Bit [4] of the Status flags returned by `_BMD` if it is possible to put the system into standby during calibration to speed up charging. Evaluating this with Bit [0] equal to 0 will abort the calibration cycle if one is in process. If the platform runtime firmware determines that the calibration cycle must be aborted (for example AC power is lost), or the calibration completes successfully, the platform runtime firmware will end the cycle automatically, clear the `_BMD` Status Flag Bit [0], and send a notify 0x82. While the calibration cycle is in process, the battery will report data normally, so the OS must disable battery alarms.

Bit [1], Bit [2], and Bit [3] may not be used in conjunction with the AML controlled calibration cycle. Having Bit [0] set will override Bit [1], Bit [2], and Bit [3]. Bit [1] will prevent the battery from charging even though AC power is connected. Bit [2] will allow the system to draw its power from the battery even though AC power is available. When the battery is no longer capable of delivering current, this setting is automatically cleared, and the system will continue running off AC power without interruption. In addition, if AC power is lost this bit will be cleared. When AC power comes back, the OS must set the bit again if the user wants to continue discharging. When the system clears this bit automatically, it will result in a change in the Status Flags returned by `_BMD`. This will cause a notify 0x82. Bit [1] is only cleared automatically if an AML controlled calibration cycle is initiated.

When a battery is discharging because Bit [2] is set, the `_PSR` method of the AC adapter device will report that AC is offline because the system is not running off of the AC adapter. If the batteries are controlled individually (Bit [3] of the `_BMD` Capabilities Flags), setting either battery to discharge will cause `_PSR` to report AC offline. If more than one battery in the system has Bit [2] set to discharge the battery, it is up to the system to decide which battery to discharge, so only on a system that discharges the batteries one at a time, a battery with Bit2 set may not be discharging if another battery in the system is being discharged.

If Batteries are not controlled individually, calling `_BMC` will initiate calibration, disable charge, and/or allow discharge on all batteries in the system. The state of these batteries will be reflected in the `_BMD` Status Flags for all batteries.

Bit [3] is set to request temporary suspension of Battery Charge Limiting. This bit may not be set unless Bit [6] of the `_BMD` Capabilities Flags is also set.

10.2.2.6 `_BMD` (Battery Maintenance Data)

This optional object returns information about the battery’s capabilities and current state in relation to battery calibration and charger control features. If the `_BMC` object (defined below) is present under a battery device, this object must also be present. Whenever the Status Flags value changes, AML code will issue a `Notify(battery_device, 0x82)`. In addition, AML will issue a `Notify(battery_device, 0x82)` if evaluating `_BMC` did not result in causing the Status Flags to be set as indicated in that argument to `_BMC`. AML is not required to issue `Notify(battery_device, 0x82)` if the Status Flags change while evaluating `_BMC` unless the change does not correspond to the argument passed to `_BMC`.

Arguments:

None

Return Value:

A Package containing the battery maintenance data as described below

Return Value Information:

`_BMD` returns a package in the format below:

```
Package {
    Status Flags           // Integer (DWORD)
    Capability Flags      // Integer (DWORD)
    Recalibrate Count     // Integer (DWORD)
    Quick Recalibrate Time // Integer (DWORD)
    Slow Recalibrate Time // Integer (DWORD)
}
```

Table 10.6: BMD Return Package Values

Field	Format	Description
Status Flags	Integer (DWORD)	<p>Bit values.</p> <p>Bit [0] is mutually exclusive with bit [1] and bit [2]. If the charger is being manually controlled, there cannot be an AML controlled calibration cycle.</p> <p>Bit[0] - 1 indicates the battery is running an AML controlled calibration cycle</p> <p>Bit[1] - 1 indicates that charging has been disabled.</p> <p>Bit[2] - 1 indicates the battery is configured to discharge while AC power is available.</p> <p>Bit[3] - 1 indicates that the battery should be recalibrated.</p> <p>Bit[4] - 1 indicates that the OS should put the system into standby to speed charging during a calibration cycle. This is optional (based on user preference) if “Slow Recalibrate Time” is not equal to 0x00000000.</p> <p>Bit[5] – 1 indicates that Battery Charge Limiting cannot be suspended due to Thermal Conditions.</p> <p>Bit[6] – 1 indicates that Battery Charge Limiting cannot be suspended for Battery Protection reasons.</p> <p>Bit [31:7] - reserved.</p>
Capability Flags	Integer (DWORD)	<p>Bit values that describe the capabilities of the battery system. These bits allows a battery system with more limited capabilities to still be calibrated by OSPM.</p> <p>Bit[0] - 1 indicates that an AML controlled calibration cycle is supported.</p> <p>Bit[1] - 1 indicates that disabling the charger is supported.</p> <p>Bit[2] - 1 indicates that discharging while running on AC is supported.</p> <p>Bit[3] - 1 indicates that calling <code>_BMC</code> for one battery will affect the state of all batteries in the system. This is for battery systems that cannot control batteries individually.</p> <p>Bit[4] - 1 indicates that calibration should be done by first fully charging the battery and then discharging it. Not setting this bit will indicate that calibration can be done by simply discharging the battery.</p> <p>Bit[5] – 1 indicates that Battery Charge Limiting suspension is supported.</p> <p>Bits[31:6] - <i>Reserved</i></p>

continues on next page

Table 10.6 – continued from previous page

Field	Format	Description
Recalibrate Count	Integer (DWORD)	This is used by battery systems that can't detect when calibration is required, but wish to recommend that the battery should be calibrated after a certain number of cycles. Counting the number of cycles and partial cycles is done by the OS. 0x00000000 - Only calibrate when Status Flag bit [3] is set. 0x00000000-0xFFFFFFFF - calibrate battery after detecting this many battery cycles.
Quick Recalibrate Time	Integer (DWORD)	Returns the estimated time it will take to calibrate the battery if the system is put into standby whenever Status Flags bit [4] is set. While the AML controlled calibration cycle is in progress, this returns the remaining time in the calibration cycle. 0x00000000 - indicates that standby while calibrating the battery is not supported. The system should remain in S0 until calibration is completed. 0x00000001 - 0xFFFFFFFFE - estimated recalibration time in seconds. 0xFFFFFFFF - indicates that the estimated time to recalibrate the battery is unknown.
Slow Recalibrate Time	Integer (DWORD)	Returns the estimated time it will take to calibrate the battery if Status Flag Bit [4] is ignored. While the AML controlled calibration cycle is in progress, this returns the remaining time in the calibration cycle. 0x00000000 - indicates that battery calibration may not be successful if Status Flags Bit [4] is ignored. 0x00000001 - 0xFFFFFFFFE - estimated recalibration time in seconds. 0xFFFFFFFF - indicates that the estimated time to recalibrate the battery is unknown.

See *Battery Calibration* for amore information.

The *Capability Flags and Recalibration Count* are used to indicate what functions are controlled by AML and what functions are controlled by OSPM as described in section 3.9.5, “Battery Calibration”. If the system does not implement an AML controlled calibration cycle (bit [0]), it may indicate using bit [1] and bit [2] that the OS can control a generic calibration cycle without prompting the user to remove the power cord. Recalibration Count may be used to indicate that the platform runtime firmware cannot determine when calibration should be preformed so bit 3 of the Status Flags will never be set. In that case, OSPM will attempt to count the number of cycles.

Bit [3] is used by systems that do not have individual control over the batteries and can only perform calibration on all batteries in the system at once. On such a system, if one battery requests calibration and another battery does not, the OS may suggest that the user remove the battery that doesn't need calibration, before initiating the calibration cycle. When this bit is set, reading the Recalibrate Time from either battery should give the time to recalibrate all batteries present in the system.

10.2.2.7 **_BMS (Battery Measurement Sampling Time)**

This object is used to set the sampling time of the battery capacity measurement, in milliseconds.

The Sampling Time is the duration between two consecutive measurements of the battery’s capacities specified in **_BST**, such as present rate and remaining capacity. If the OSPM makes two succeeding readings through **_BST** beyond the duration, two different results will be returned.

The OSPM may read the Max Sampling Time and Min Sampling Time with **_BIX** during boot time, and set a specific sampling time within the range with **_BMS**.

Arguments:(1)

Arg0 - SamplingTime (Integer(DWORD)) the sampling time of battery capacity measurement:

0x00000001 - 0xFFFFFFFF (in units of millisecond)

Return Value:

An Integer (DWORD) containing a result code as follows:

- 0x00000000 - Success.
- 0x00000001 - Failure to set Battery Measurement Sampling Time because it is out of the battery’s measurement capability.
- 0x00000002 - 0xFFFFFFFF - Reserved.

10.2.2.8 **_BPC (Battery Power Characteristics)**

This optional object returns static values that are used to configure power threshold support in the platform firmware. OSPM can use the information to determine the capabilities of power delivery and threshold support for each battery in the system.

Arguments:

None

Return Value:

A Package containing the system power characteristics on the battery path and the power threshold support in the platform firmware like the Embedded Controller.

Return Value Information:

_BPC returns a package in the format below:

```
Package () {
    Revision,                // Integer
    Power Threshold Support, // Integer
    Max Instantaneous Peak Power Threshold, // Integer
    Max Sustainable Peak Power Threshold // Integer
}
```

Table 10.7: **_BPC Return Package Values**

Field	Format	Description
Revision	Integer	Current revision is 1
Power Threshold Support Capability	Integer	This is the power threshold support capability that must be declared by the platform firmware to indicate what power threshold it supports. Refer to the table below for more details.

continues on next page

Table 10.7 – continued from previous page

Field	Format	Description
Maximum Instantaneous Peak Power Threshold Value	Integer	The maximum threshold for instantaneous peak output power of the battery. This defines the maximum threshold setting for use as an input to <code>_BPT</code> . The unit for this value is mW or mA, based on the Power Unit value returned by <code>_BIX</code> .
Maximum Sustainable Peak Power Threshold Value	Integer	The maximum threshold for sustainable peak output power of the battery. This defines the maximum threshold setting for use as an input to <code>_BPT</code> . The unit for this value is mW or mA, based on the Power Unit value returned by <code>_BIX</code> .

Table 10.8: **Battery Power Threshold Support Capability**

Bit	Interpretation
[1:0]	0 – The platform firmware does not support thresholds for the battery Peak Power. 1 – The platform firmware supports the threshold for the battery Instantaneous Peak Power. 2 – The platform firmware supports the threshold for the battery Sustainable Peak Power. 3 – The platform firmware supports the threshold for both the battery Instantaneous Peak Power and the Sustainable Peak Power.
[31:2]	<i>Reserved (must be 0)</i>

10.2.2.9 `_BPS` (Battery Power State)

This optional object returns the power delivery capabilities of the battery at the present time. If multiple batteries are present within the system, the sum of peak power levels from each battery can be used to determine the total available power.

Arguments:

None

Return Value:

A Package containing the battery power delivery capabilities as described below

Return Value Information:

`_BPS` returns a package in the format below:

```

Package () {
    Revision,                // Integer
    Instantaneous Peak Power Level, // Integer
    Instantaneous Peak Power Period, // Integer
    Sustainable Peak Power Level, // Integer
    Sustainable Peak Power Period, // Integer
}
    
```

Table 10.9: `_BPS` Return Package Values

Field	Format	Description
Revision	Integer	Current revision is 1

continues on next page

Table 10.9 – continued from previous page

Field	Format	Description
Instantaneous Peak Power Level	Integer	The instantaneous peak output power of the battery in mW or mA, based on the Power Unit value returned by <code>_BIX</code> . The time period is specified in the “Instantaneous Peak Power Period” variable. This value shall account for the battery resistances, and the minimum system voltage. If this feature is not supported, then the platform firmware shall report Zero for this field.
Instantaneous Peak Power Period	Integer	The time period in milliseconds that the battery can supply as specified in the “Instantaneous Peak Power Level” variable. If this feature is not supported, then the platform firmware shall report Zero for this field.
Sustainable Peak Power Level	Integer	The sustainable peak output power of the battery in mW or mA, based on the Power Unit value returned by <code>_BIX</code> . The time period is specified by the “Sustainable Peak Power Period” variable. This value shall account for the battery resistances, and the minimum system voltage. If this feature is not supported, then the platform firmware shall report Zero for this field.
Sustainable Peak Power Period	Integer	The time period in milliseconds that the battery can supply as specified in the “Sustainable Peak Power Level” variable. If this feature is not supported, then the platform firmware shall report Zero for this field.

10.2.2.10 `_BPT` (Battery Power Threshold)

This optional object may be present under a battery device. OSPM must read `_BPC` first to determine the power delivery capability threshold support in the platform firmware and invoke this Method in order to program the threshold accordingly. If the platform does not support battery peak power thresholds, this Method should not be included in the namespace.

OSPM can call this object to set a relative battery peak power capability change threshold. A notification must be issued when the value from the fuel gauge has changed by the amount that is greater than or equal to the last argument passed to `_BPT`. For example, if the last threshold passed to `_BPT` is 250mW and ID is 0x1 (Instantaneous Peak Power), the platform must generate a GPE when the battery instantaneous peak power delivery capability has changed by 250mW or more since the threshold was last set. The AML handler for the SCI interrupt should issue a Notify (<battery_device>, 0x83). This will cause the OSPM to re-evaluate `_BPS` to obtain the current battery power delivery capability, and may call `_BPT` to set a new threshold value or re-arm the threshold crossing event for the same relative threshold value.

OSPM determines an appropriate threshold value for the battery device based on the power delivery capability from the battery and the requirements of the power control algorithm. The upper bound of instantaneous peak power or sustainable peak power can be queried through `_BPS` when the battery state of charge is 100%. If the battery power delivery capability is used to adjust the peak system performance, then a low threshold will be desired. If it is used for fail-safe protection, then a high threshold value can be used.

OSPM checks the power threshold support capability of the firmware through `_BPC` before it programs the power threshold through `_BPT`. The power threshold ID selected must be supported by the platform firmware. If the platform firmware does not support the power threshold for the Instantaneous Peak Power of the battery, setting a threshold for the Instantaneous Peak Power through `_BPT` will be ignored by the platform firmware. The firmware should set the return value 0x00000004 to indicate that the threshold request is not supported. If the threshold ID matches and the firmware is able to process the request, the return value should be 0x00000000. Otherwise, a proper return value should be set.

Arguments: (3)

Arg0 – Revision, Integer. For this version of the specification, this version is 1.

Arg1 – Threshold ID, Integer:

- 0: Clear all threshold trip points
- 1: Set Instantaneous Peak Power Threshold
- 2: Set Sustainable Peak Power Threshold

Arg2 – Threshold value, integer. This is the value in mW or mA, based on the Power Unit field returned by `_BIX`, used to set a threshold. A value of 0 disables the selected threshold. The value for either threshold must not be greater than the maximum values reported by `_BPC`.

Return Value:

An Integer containing the status of the operation:

- 0x00000000 – Success
- 0x00000001 – Failure, invalid threshold value
- 0x00000002 – Failure, hardware timeout
- 0x00000003 – Failure, unknown hardware error
- 0x00000004 – Failure, unsupported threshold type
- 0x00000005 – Failure, unsupported revision
- 0x00000006 and above - Reserved

10.2.2.11 `_BST` (Battery Status)

This object returns the present battery status. Whenever the Battery State value changes, the system will generate an SCI to notify the OS.

Arguments:

None

Return Value:

A Package containing the battery status as described below

Return Value Information:

`_BST` returns a package in the format below

```
Package {
    Battery State           // Integer (DWORD)
    Battery Present Rate    // Integer (DWORD)
    Battery Remaining Capacity // Integer (DWORD)
    Battery Present Voltage // Integer (DWORD)
}
```

Table 10.10: BST Return Package Values

Element	Format	Description
Battery State	Integer (DWORD)	<p>Bit values. Notice that the Charging bit and the Discharging bit are mutually exclusive and must not both be set at the same time. Even in critical state, hardware should report the corresponding charging/discharging state.</p> <p>Bit [0] - 1 indicates the battery is discharging.</p> <p>Bit [1] - 1 indicates the battery is charging.</p> <p>Bit [2] - 1 indicates the battery is in the critical energy state (see <i>Low Battery Levels</i>). This does not mean battery failure.</p> <p>Bit [3] - 1 indicates the battery is in the Battery Charge Limiting state (see <i>Section 3.9.6</i>).</p>
Battery Present Rate	Integer (DWORD)	<p>Returns the power or current being supplied or accepted through the battery's terminals (direction depends on the Battery State value). The Battery Present Rate value is expressed as power [mWh] or current [mAh] depending on the Power Unit value. Batteries that are rechargeable and are in the discharging state are required to return a valid Battery Present Rate value.</p> <p>0x00000000 - 0x7FFFFFFF in [mW] or [mA] 0xFFFFFFFF - Unknown rate</p>
Battery Remaining Capacity	Integer (DWORD)	<p>Returns the estimated remaining battery capacity. The Battery Remaining Capacity value is expressed as power [mWh] or current [mAh] depending on the Power Unit value. Batteries that are rechargeable are required to return a valid Battery Remaining Capacity value.</p> <p>0x00000000 - 0x7FFFFFFF in [mWh] or [mAh] 0xFFFFFFFF - Unknown capacity</p>
Battery Present Voltage	Integer (DWORD)	<p>Returns the voltage across the battery's terminals. Batteries that are rechargeable must report Battery Present Voltage.</p> <p>0x00000000 - 0x7FFFFFFF in [mV] 0xFFFFFFFF - Unknown voltage Note: Only a primary battery can report unknown voltage.</p>

Note that when the battery is a primary battery (a non-rechargeable battery such as an Alkaline-Manganese battery) and cannot provide accurate information about the battery to use in the calculation of the remaining battery life, the Control Method Battery can report the percentage directly to OS. It does so by reporting the Last Full Charged Capacity =100 and BatteryPresentRate=0xFFFFFFFF. This means that Battery Remaining Capacity directly reports the battery's remaining capacity [%] as a value in the range 0 through 100 as follows:

$$\text{Remaining Battery Percentage}[\%] = \frac{\text{Battery Remaining Capacity [=0 ~ 100]}}{\text{Last Full Charged Capacity [=100]}} * 100$$

Fig. 10.4: Remaining Battery Percent Formula

$$\text{Remaining Battery Life [h]} = \frac{\text{Battery Remaining Capacity [mAh/mWh]}}{\text{Battery Present Rate [=0xFFFFFFFF]}} = \text{unknown}$$

Fig. 10.5: Remaining Battery Life Formula

10.2.2.12 _BTH (Battery Throttle Limit)

This method will communicate to the platform firmware the thermal throttle limit set by on the battery.

Arguments:

Arg0 - An integer from 0 to 100 containing the battery thermal throttle limit in percentage. At 100%, the battery can be charged at maximum current.

Return Value:

None.

Note:: Firmware is responsible for taking the current thermal throttle limit into account when engaging charging

Example:

```
Scope(\_SB.PCI0.ISA0) {
    Device(EC0) {
        Name(_HID, EISAID("PNP0C09")) // ID for this EC
        // current resource description for this EC
        Name(_CRS, ResourceTemplate() {
            IO(Decode16, 0x62, 0x62, 0, 1)
            IO(Decode16, 0x66, 0x66, 0, 1)
        })
        Name(_GPE, 0) // GPE index for this EC
        // create EC's region and field for thermal support
        OperationRegion(EC0, EmbeddedControl, 0, 0xFF)
        Field(EC0, ByteAcc, Lock, Preserve) {
            TMP, 16, // current temp
            PSV, 16, // passive cooling temp
            BTH 16, // battery charge rate limit
        }
        // following is a method that OSPM will schedule after
        // it receives an SCI and queries the EC to receive value 7
        Method(_Q07) {
            Notify (\_SB.PCI0.ISA0.EC0.TZ0, 0x80) // end of Notify method
                                                    // create a thermal zone
        }
        ThermalZone (TZ0) {
            Method(_TMP) { Return (\_SB.PCI0.ISA0.EC0.TMP )} // get current temp
            Method(_PSV) { Return (\_SB.PCI0.ISA0.EC0.PSV) } // passive cooling temp
            Name(_TZD, Package (){\_SB.PCI0.ISA0.EC0.BAT0}) // passive cooling devices
            Name(_TC1, 4) // bogus example constant
            Name(_TC2, 3) // bogus example constant
            Name(_TSP, 150) // passive sampling = 15 sec
        }
    }
}
```

(continues on next page)

(continued from previous page)

```

    } // end of TZ0
Device (BAT0) {
    Name(_HID, "PNP0C0A")
    Name(_UID, One)
    Method (_BTH, 0x1, NotSerialized) {
        Store(Arg0, \_SB.PCI0.ISA0.EC0.BTH)
    }
    // additional battery objects
}
} // end of ECO
} // end of \_SB.PCI0.ISA0_
↪scope
} // end of \_SB scope

```

10.2.2.13 _BTM (Battery Time)

This optional object returns the estimated runtime of the battery while it is discharging.

Arguments:(1)

Arg0 - An Integer containing the rate at which the battery is expected to discharge

0 - Indicates that the battery will continue discharging at the current rate. The rate should be based on the average rate of drain, not the current rate of drain.

1 - 0x7FFFFFFF The discharge rate (in mA or mW)

Return Value:

An Integer containing the estimated remaining runtime:

0 - The input discharge rate (Arg0) is too large for the battery or batteries to supply. If the input argument was 0, this value indicates that the battery is critical. 1 - 0xFFFFFFF - Estimated runtime in seconds 0xFFFFFFF - Runtime is unknown

10.2.2.14 _BTP (Battery Trip Point)

This object is used to set a trip point to generate an SCI whenever the Battery Remaining Capacity reaches or crosses the value specified in the _BTP object. Specifically, if Battery Remaining Capacity is less than the last argument passed to _BTP, a notification must be issued when the value of Battery Remaining Capacity rises to be greater than or equal to this trip-point value. Similarly, if Battery Remaining Capacity is greater than the last argument passed to _BTP, a notification must be issued when the value of Battery Remaining Capacity falls to be less than or equal to this trip-point value. The last argument passed to _BTP will be kept by the system.

If the battery does not support this function, the _BTP control method is not located in the namespace. In this case, the OS must poll the Battery Remaining Capacity value.

Arguments:(1)

Arg0 - An Integer containing the new battery trip point 0 - Clear the trip point 1 - 0x7FFFFFFF - New trip point, in units of mWh or mAh depending on the Power Units value

Return Value:

None

10.2.2.15 _OSC Definition for Control Method Battery

_OSC for a control method battery is uniquely identified by the following UUID:

F18FC78B-0F15-4978-B793-53F833A1D35B

The Revision 1 capabilities described under this _OSC are defined in the table below.

Table 10.11: **Control Method Battery _OSC Capabilities DWORD2 Bit Definitions**

Capabilities DWORD2 bits	Interpretation
0	0 - OS does not support revised battery granularity definition. 1 - OS supports revised battery granularity definition.
1	0 - OS does not support specifying wake on low battery user preference. 1 - OS supports specifying wake on low battery user preference, See <i>_BLT (Battery Level Threshold)</i> for more information.
2	0 - OS does not support battery power delivery capability threshold notifications. 1 - OS supports battery power delivery capability threshold notifications.
3-31	<i>Reserved</i>

Bits defined in Capabilities DWORD2 provide information regarding OS supported features. Contents in DWORD2 are passed one-way; the OS will disregard the corresponding bits of DWORD2 in the Return Code.

10.3 AC Adapters and Power Source Objects

The Power Source objects describe the system’s power source. These objects may be defined under a Power Source device which is declared using a hardware identifier (_HID) of “ACPI0003”. Typically there will be a power source device for each physical power supply contained within the system. However, in cases where the power supply is shared, as in a blade server configuration, this may not be possible. Instead the firmware can choose to expose a virtual power supply that represents one or more of the physical power supplies.

Table 10.12: **Power Source Objects**

Object	Description
_PSR	Returns whether this power source device is currently online.
_PCL	List of pointers to devices this power source is powering.
_PIF	Returns static information about a power source.
_PRL	List of pointers to all the other power source devices that belong in the same redundancy group of which the power supply device is a member.

10.3.1 _PSR (Power Source)

Returns whether the power source device is currently in use. This can be used to determine if system is running off this power supply or adapter. On mobile systems this will report that the system is not running on the AC adapter if any of the batteries in the system is being forced to discharge. In systems that contains multiple power sources, this object reports the power source's online or offline status.

Arguments:

None

Return Value:

An Integer containing the power source status:

0 - Off-line (not on AC power) 1 - On-line

10.3.2 _PCL (Power Consumer List)

This object evaluates to a list of pointers, each pointing to a device or a bus powered by the power source device. Pointing to a bus indicates that all devices under the bus are powered by the power source device.

Arguments:

None

Return Value:

A variable-length **Package** containing a list of **References** to devices or buses

10.3.3 _PIF (Power Source Information)

This object returns information about the Power Source, which remains constant until the Power Source is changed. When the power source changes, the platform issues a Notify(0x0) (Bus Check) to the Power Source device to indicate that OSPM must re-evaluate the _PIF object.

Arguments:

None

Return Value:

A Package with the following format:

```
Package {
    Power Source State           // Integer (DWORD)
    Maximum Output Power        // Integer (DWORD)
    Maximum Input Power         // Integer (DWORD)
    Model Number                // String (ASCII)
    Serial Number               // String (ASCII)
    OEM Information             // String (ASCII)
}
```

Table 10.13: PIF Method Result Codes

Element	Object Type	Description
Power Source State	Integer (DWORD)	Bit values that describe the type of this Power Source. These bits are especially useful in server scenarios. Bit [0] - indicates the power source is a redundant one. If this bit is set, this Power Source device should have a <code>_PRL</code> object. Bit [1] - indicates the power source is being shared across multiple machines. Bit [31:2] - Reserved.
Maximum Output Power	Integer (DWORD)	The maximum rated output wattage of the power source device. [mW] 0xFFFFFFFF is returned if the information is unavailable.
Maximum Input Power	Integer (DWORD)	The maximum rated input wattage of the power source device. [mW] 0xFFFFFFFF is returned if the information is unavailable.
Model Number	String (ASCIIZ)	OEM-specific Power Source model number. This element is optional and an empty string (a null character) should be used if this is not supported.
Serial Number	String (ASCIIZ)	OEM-specific Power Source serial number. This element is optional and an empty string (a null character) should be used if this is not supported.
OEM Information	String (ASCIIZ)	OEM-specific information that the UI uses to display about the Power Source device. This element is optional and a NULL string should be used if this is not supported.

10.3.4 `_PRL` (Power Source Redundancy List)

This optional object evaluates to a list of Power Source devices that are in the same redundancy grouping as Power Source device under which this object is defined. A redundancy grouping is a group of power supplies that together provide redundancy. For example, on a system that contains two power supplies that each could independently power the system, both power supplies would be part of the same redundancy group. This is used in conjunction with the Power Source State values specified by the `_PIF` object.

The entries should be in the format of a fully qualified ACPI namespace path.

Arguments:

None

Return Value:

A variable-length Package containing a list of References to power source devices. It has the following format:

```
Package {
    Power source[0], // Reference
    Power source[1], // Reference
    Power source[n] // Reference
}
```

10.4 Power Meters

The following section describes Power Metering objects. These objects may be defined under a Power Meter device which is declared using the ACPI000D hardware identifier (_HID).

Table 10.14: **Power Meter Objects**

Object	Description
_GAI	Gets the averaging interval used by the power meter.
_GHL	Gets the hardware power consumption limit that is enforced by the Power Meter.
_PAI	Sets the power averaging interval used by the Power Meter.
_PMC	Returns Power Meter capabilities.
_PMD	Returns a list of devices whose power consumption is measured by the Power Meter.
_PMM	Returns the power consumption measured by the Power Meter.
_PTP	Sets Power Meter device trip points.
_SHL	Sets the hardware power consumption limit that is enforced by the Power Meter.

10.4.1 _PMC (Power Meter Capabilities)

This object returns the capabilities of a power meter. This information remains constant unless either the power meter's firmware or the BMC hardware changes, at which time the platform is required to send Notify(power_meter, 0x80) for the OSPM to re-evaluate _PMC.

Arguments:

None

Return Value:

A Package with the following format:

```
Package {
    Supported Capabilities           // Integer (DWORD)
    Measurement Unit                 // Integer (DWORD)
    Measurement Type                 // Integer (DWORD)
    Measurement Accuracy             // Integer (DWORD)
    Measurement Sampling Time        // Integer (DWORD)
    Minimum Averaging Interval       // Integer (DWORD)
    Maximum Averaging Interval       // Integer (DWORD)
    Hysteresis Margin                // Integer (DWORD)
    Hardware Limit Is Configurable    // Boolean (DWORD)
    Min Configurable Hardware Limit   // Integer (DWORD)
    Max Configurable Hardware Limit   // Integer (DWORD)
    Model Number                     // String
    Serial Number                     // String
    OEM Information                   // String
}
```

Table 10.15: PMC Method Result Codes

Element	Object Type	Description
Supported Capabilities	Integer (DWORD)	A bitmask that represents the capability flags: Bit [0] - indicates the power meter supports measurement. Bit [1] - indicates the power meter supports trip points. Bit [2] - indicates the power meter supports hardware enforced limit. Bit [3] - indicates that the power meter supports notifications when the hardware limit is enforced. Bit [7:4] - reserved. Bit [8] - indicates the power meter only reports data when discharging. This applies to power meters that are battery-type devices. Bit [9:31] Reserved
Measurement Unit	Integer (DWORD)	The units used by the power meter to report measurement and configure trip points and hardware enforced limits. 0x00000000 - indicates measurements are reported in [mW].
Measurement Type	Integer (DWORD)	The type of measurement the power meter is measuring. A power meter may measure either input or output power, not both. 0x00000000 - indicates the power meter is measuring input power. 0x00000001 - indicates the power meter is measuring output power.
Measurement Accuracy	Integer (DWORD)	The accuracy of the power meter device, in thousandth of a percent. (0% - 100.000%) For example, The value 80000 would mean 80% accuracy.
Measurement Sampling Time	Integer (DWORD)	The sampling time of the power meter device, in milliseconds. This is the minimum amount of time at which the measurement value will change. In other words, the same reading will be returned by _PMM if OSPM makes 2 consecutive reads within a measurement sampling time. 0xFFFFFFFF is returned if the information is unavailable.
Minimum Averaging Interval	Integer (DWORD)	This is the minimum length of time (in milliseconds) within which the power meter firmware is capable of averaging the measurements within it.
Maximum Averaging Interval	Integer (DWORD)	This is the maximum length of time (in milliseconds) within which the power meter firmware is capable of averaging the measurements within it.
Hysteresis Margin	Integer (DWORD)	The margin used by the BMC for hysteresis, in the unit of [Measurement Unit / Measurement Sampling Time]. This indicates the margin built around the trip points and hardware limit notifications. This margin prevents unnecessary notifies to the OSPM when the reading is fluctuating very close to one of the trip points or the hardware limit. 0xFFFFFFFF is returned if the information is unavailable.

continues on next page

Table 10.15 – continued from previous page

Element	Object Type	Description
Hardware Limit Is Configurable	Integer (DWORD)	This boolean value represents whether hardware enforced limit is configurable by the OSPM: 0x00000000 (zeros) - indicates the limit is read-only. 0xFFFFFFFF (ones) - indicates the limit is writable.
Minimum Configurable Hardware Limit	Integer (DWORD)	The minimum value that can be configured into the hardware enforced limit, expressed in the units as specified by Measurement Unit.
Maximum Configurable Hardware Limit	Integer (DWORD)	The maximum value that can be configured into the hardware enforced limit, expressed in the units as specified by Measurement Unit.
Model Number	String (ASCII)	OEM-specific Power meter model number. This element is optional and an empty string (a null character) should be used if this is not supported.
Serial Number	String (ASCII)	OEM-specific Power meter serial number. This element is optional and an empty string (a null character) should be used if this is not supported.
OEM Information	String (ASCII)	OEM-specific information that the UI uses to display about the Power meter device. This element is optional and a NULL string should be used if this is not supported.

10.4.2 _PTP (Power Trip Points)

This object sets the upper and lower trip points for the power meter device. These 2 trip points define a hysteresis range for which the OSPM can tolerate without re-reading the current measurement via _PMM. When the power meter draw goes outside the range, a Notify(power_meter, 0x81) should be sent to notify the OSPM, at which time the OSPM should re-evaluate _PMM and also set a pair of trip points around the newest reading. If the latest value measured by the power meter is outside of the range defined by the trip points by the time _PTP is called, a result code is returned.

Arguments:(2)

Arg0 (Integer) : Upper Trip Point

Arg1 (Integer) : Lower Trip Point

Return Value:

An Integer containing the status of the operation:

- 0x00000000 - Success
- 0x00000001 - Failure to set trip points because latest measurement is out of range
- 0x00000002 - Failure to set trip points due to hardware timeout
- 0x00000003 - Failure to set trip points due to unknown hardware error
- 0x00000004 - 0xFFFFFFFF - Reserved

10.4.3 **_PMM (Power Meter Measurement)**

This object returns the latest measurement reading from the power meter device. The value returned represents real power (i.e. power factor is included in the value). In most cases this is a rolling average value that is computed by the firmware over an averaging interval. On systems where this interval can be configured, the `_PAI` object should be present under the power meter device (see [Section 10.4.4](#)).

Arguments

None

Return Value

An Integer is returned to represent the latest measurement reading from the power meter device. This value should be in the unit specified in the power meter capabilities (typically in milliwatts), and is required to be the RMS value if the power meter is measuring in AC. If an error occurs while obtaining the meter reading or if the value is not available then an Integer with all bits set is returned.

10.4.4 **_PAI (Power Averaging Interval)**

This object sets the averaging interval used by the power meter. The averaging interval is the total time the power meter will take instantaneous measurement samples for, before averaging them to produce the average power measurement as returned by `_PMM`. If the platform changes the averaging interval independently from OSPM, the platform must issue a `Notify(power_meter, 0x84)` to indicate the change to the OSPM. Upon receiving the notification, OSPM evaluates the `_GAI` object to read the new averaging interval.

Arguments:(1)

Arg0 - An Integer that represents the desired value OSPM chose to be the power averaging interval, in milliseconds. This value needs to be within the minimum and maximum averaging interval as specified by `_PMC`. Otherwise, a failure result code is returned.

Return Value:

An Integer containing the status of the operation:

- 0x00000000 - Success
- 0x00000001 - Failure to set power averaging interval because it is out of range
- 0x00000002 - Failure to set power averaging interval due to hardware timeout
- 0x00000003 - Failure to set power averaging interval due to unknown hardware error
- 0x00000004 - 0xFFFFFFFF - Reserved

10.4.5 **_GAI (Get Averaging Interval)**

This object gets the averaging interval used by the power meter. The averaging interval is the total time the power meter will take instantaneous measurement samples for, before averaging them to produce the average power measurement as returned by `_PMM`. If the platform changes the averaging interval independently from OSPM, the platform must issue a `Notify(power_meter, 0x84)` to indicate the change to the OSPM. Upon receiving the notification, OSPM evaluates the `_GAI` object to read the new averaging interval.

Arguments:

None

Return Value:

An Integer containing the currently configured power averaging interval, in milliseconds. If an error occurs while obtaining the averaging interval or if the value is not available then an Integer with all bits set is returned.

10.4.6 **_SHL (Set Hardware Limit)**

This object sets the hardware limit enforced by the power meter. This limit, if supported, will be enforced by the circuitry on the platform hardware, to the best of its effort. This value is typically also configurable via other out-of-band management mechanism. When the enforcement happens, the platform should send a Notify(power_meter, 0x83) to the OSPM.

Arguments:(1)

Arg0 - An Integer value that represent the desired value OSPM chose as the hardware enforced limit of this power meter, in the unit specified in `_PMC`. This value needs to be within the minimum and maximum hardware limit as specified by `_PMC`. Otherwise, a failure result code is returned.

Return Value:

An Integer containing the status of the operation:

```
- 0x00000000 - Success
- 0x00000001 - Failure to set hardware limit because it is out of range
- 0x00000002 - Failure to set hardware limit due to the hardware timeout
- 0x00000003 - Failure to set hardware limit due to unknown hardware error
- 0x00000004 - 0xFFFFFFFF - Reserved
```

10.4.7 **_GHL (Get Hardware Limit)**

This object gets the hardware limit enforced by the power meter. This limit can be changed by either the OSPM or by the platform through some out-of-band mechanism. When this value is changed, a Notify(power_meter, 0x82) should be sent to notify the OSPM to re-read the hardware limit. If an error occurs while obtaining the hardware limit or if the value is not available then an Integer with all bits set is returned.

Arguments:

None

Return Value:

An Integer is returned to represent the currently configured hardware enforced limit of the power meter, in the unit specified in `_PMC`.

10.4.8 **_PMD (Power Metered Devices)**

This object evaluates to a package of device names. Each name corresponds to a device in the ACPI namespace that is being measured by the power meter device. The measurement reported by the power meter is roughly correspondent to the total power draw of all the devices returned.

If this control method is present, the package needs to contain at least 1 device. On a system that supports power metering, a system power meter that measures the power draw of the entire system should always be present and have a `_PMD` that contains `_SB` as its sole entry.

Arguments:

None

Return Value:

A variable-length Package consisting of references to devices being measured by the power meter:

```
Package {
    Power Meter[0]           // NamePath
    Power Meter[1]           // NamePath
    ...
    Power Meter[n]           // NamePath
}
```

10.5 Wireless Power Controllers

FCC regulations dictate reduced output power levels for wireless devices in the presence of a human body. To get platform certifications and for regulatory compliance, wireless devices put static transmit power limit data in device memory (either EEPROM or flash) and apply it on a per band/country basis. FCC regulations allow devices to dynamically reduce Effective Isotropically Radiated Power (EIRP) when in close proximity to a human body to mitigate its adverse effects.

On current platforms, a dedicated Specific Absorption Rate (SAR) sensor for each wireless device is used for notifying the wireless device that the system is in close proximity to a human body. This solution requires multiple SAR sensors for systems that have multiple wireless devices, and doesn't provide any mechanism for the wireless devices to collaborate for better efficiency.

The idea is to create a well-defined Wireless Power Calibration ACPI device with an ACPI event which can constitute the basis for notifying the Operating System (OS) and all other wireless devices on a given system. Wireless Power Calibration device event can be triggered from any proximity sensor device or by wireless device to mitigate interference from other wireless devices as well. The OS can then map specific notifications to each wireless device to invoke specific actions.

1. Define Plug and play ID for Wireless Power Calibration device(ACPI0014)

Wireless Power Calibration Device. This device can have a control method to sense proximity using platform defined sensor such as SAR, depth camera, touch device etc.

Device can also have control method to broadcast other wireless device notifying the user proximity change or in band interference.

2. Define a notification value for the device

Notifying the Wireless Power Calibration device with specific ACPI notify event id will enable wireless device or platform drivers to notify if EIRP needs to be regulated.

Table 10.16: **Wireless Power Calibration**

Object	Description
_WPC	Indicate the WPC device current operational state.[Required]
_WPP	Evaluate the WPC object and return the status of last operational state.[Optional]

10.5.1 Wireless Power Calibration Device

The following sections illustrate the operation and definition of the control method based Wireless Power Calibration Device (WPC).

10.5.2 Wireless Power Calibration (_WPC)

The wireless power calibration can support the _WPC methods per participant device to calibrate power and notify the participant device as the case may be. (i.e. Either direct proximity based power calibration or notification for interference mitigation).

The _WPC method of the WPC device functions as a notifier to the participant wireless devices and indicates either the messaging is for interference mitigation or direct power calibration.

Return Value:

- 0x00 - Direct Proximity Power Control
- 0x01 - Interference Mitigation Control
- 0x02 - Operational Band Change Control
- 0xFF - Reserved

10.5.3 Wireless Power Polling (_WPP)

This optional method evaluates the recommended polling frequency (in tenths of seconds) for this Wireless Power Calibration device. A value of zero - or the absence of this object when other WPC objects are defined - indicates that the OS does not need to poll the WPC device in order to detect meaningful changes in Wireless power calibration (the hardware is capable of generating asynchronous notifications).

Argument:

None

Return:

An Integer containing the recommended polling frequency in tenths of seconds. A value of zero indicates that polling is not required.

10.6 Wireless Power Calibration Event

To communicate the changes in wireless power transmission or interference mitigation to the OSPM. AML code should issue a Notify (wpc_device, 0xXX) whenever a change in power calibration or interference mitigation is required to happen. The OS receives this notification and may call the _WPD control method to determine the notification action associated with it. Event generated may contain the information related to associate action that recipient devices need to take.

WPD notification should occur whenever a change in power transmission needed either as a result of human proximity or interference mitigation. The granularity of the interference mitigation and power transmission can be address as per the operational device characteristics.

The WPC notification for interference mitigation will generate pairwise event among participant devices or multicast is if the interference is observed in all the bands of operations involving the wireless devices.

Table 10.17: Wireless Power Control Notification Values

Hex Value	Description
0x80	Proximity based power calibration
0x81	Interference mitigation between Wifi (802.11) and Bluetooth devices
0x82-85	Reserved for Wifi/BT interference mitigation for later use
0x86	Interference mitigation between Wifi (802.11) and LTE/3GPP bands
0x87-90	Reserved for Wifi/LTE/3GPP interference mitigation for later use
0x91	Interference mitigation between Bluetooth and LTE/3GPP devices
0x92-0x95	Reserved for Bluetooth and LTE/3GPP interference mitigation for later use

10.7 Example: Power Source and Power Meter Namespace

Figure below-shows the ACPI namespace for a computer with a power meter, AC adapter and two batteries associated with a docking station which itself has an AC adapter.

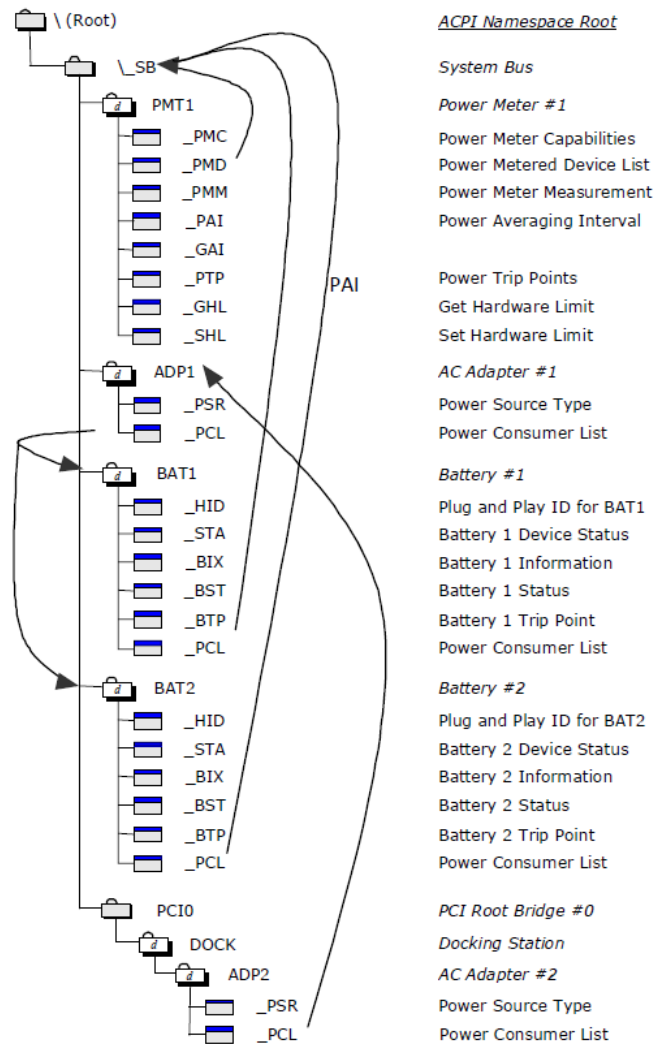

Fig. 10.6: Power Meter and Power Source/Docking Namespace Example

THERMAL MANAGEMENT

This chapter describes the ACPI thermal model and specifies the ACPI Namespace objects OSPM uses for thermal management of the platform.

11.1 Thermal Control

ACPI defines interfaces that allow OSPM to be proactive in its system cooling policies. With OSPM in control of the operating environment, cooling decisions can be made based on the system's application load, the user's preference towards performance or energy conservation, and thermal heuristics. Graceful shutdown of devices or the entire system at critical heat levels becomes possible as well. The following sections describe the ACPI thermal model and the ACPI Namespace objects available to OSPM to apply platform thermal management policy.

The ACPI thermal model is based around conceptual platform regions called thermal zones that physically contain devices, thermal sensors, and cooling controls. Generally speaking, the entire platform is one large thermal zone, but the platform can be partitioned into several ACPI thermal zones if necessary to enable optimal thermal management.

ACPI Thermal zones are a logical collection of interfaces to temperature sensors, trip points, thermal property information, and thermal controls. Thermal zone interfaces apply either thermal zone wide or to specific devices, including processors, contained within the thermal zone. ACPI defines namespace objects that provide the thermal zone-wide interfaces in [Section 11.4](#). A subset of these objects may also be defined under devices. OS implementations compatible with the ACPI 3.0 thermal model, interface with these objects but also support OS native device driver interfaces that perform similar functions at the device level. This allows the integration of devices with embedded thermal sensors and controls, perhaps not accessible by AML, to participate in the ACPI thermal model through their inclusion in the ACPI thermal zone. OSPM is responsible for applying an appropriate thermal policy when a thermal zone contains both thermal objects and native OS device driver interfaces for thermal control.

Some devices in a thermal zone may be comparatively large producers of thermal load in relation to other devices in the thermal zone. Devices may also have varying degrees of thermal sensitivity. For example, some devices may tolerate operation at a significantly higher temperature than other devices. As such, the platform can provide OSPM with information about the platform's device topology and the resulting influence of one device's thermal load generation on another device. This information must be comprehended by OSPM for it to achieve optimal thermal management through the application of cooling controls.

ACPI expects all temperatures to be represented in tenths of degrees. This resolution is deemed sufficient to enable OSPM to perform robust platform thermal management.

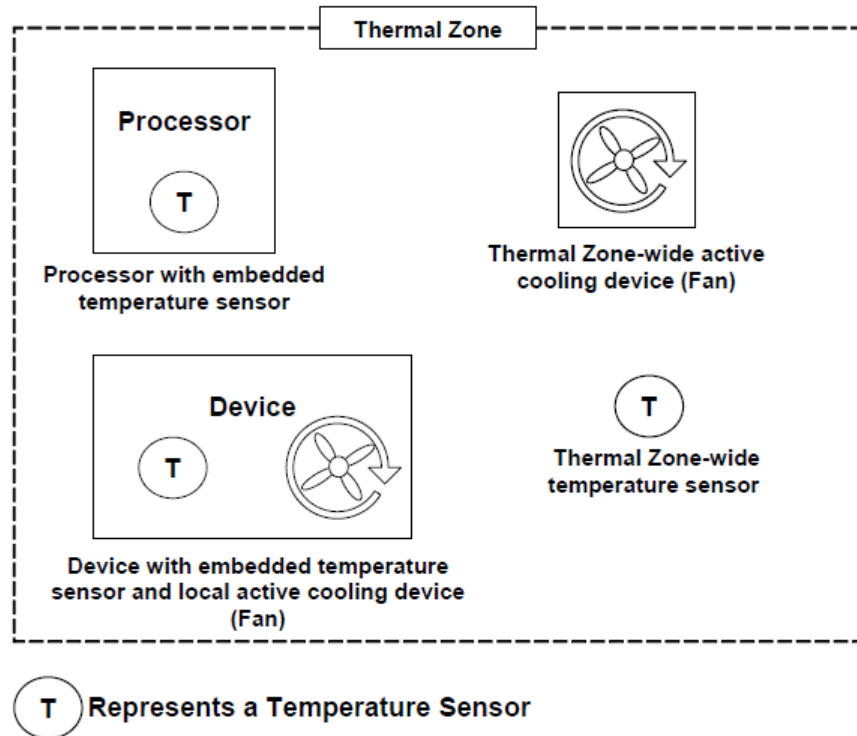

Fig. 11.1: ACPI Thermal Zone

11.1.1 Active, Passive, and Critical Policies

There are three cooling policies that OSPM uses to control the thermal state of the hardware. The policies are active, passive and critical.

- **Active Cooling.** OSPM takes a direct action such as turning on one or more fans. Applying active cooling controls typically consume power and produce some amount of noise, but are able to cool a thermal zone without limiting system performance. Active cooling temperature trip points declare the temperature thresholds OSPM uses to decide when to start or stop different active cooling devices.
- **Passive Cooling.** OSPM reduces the power consumption of devices to reduce the temperature of a thermal zone, such as slowing (throttling) the processor clock. Applying passive cooling controls typically produces no user-noticeable noise. Passive cooling temperature trip points specify the temperature thresholds where OSPM will start or stop passive cooling.
- **Critical Trip Points.** These are threshold temperatures at which OSPM performs an orderly, but critical, shutdown of a device or the entire system. The `_HOT` object declares the critical temperature at which OSPM may choose to transition the system into the S4 sleeping state, if supported, The `_CRT` object declares the critical temperature at which OSPM must perform a critical shutdown.

When a thermal zone appears in the ACPI Namespace or when a new device becomes a member of a thermal zone, OSPM retrieves the temperature thresholds (trip points) at which it executes a cooling policy. When OSPM receives a temperature change notification, it evaluates the thermal zone's temperature interfaces to retrieve current temperature values. OSPM compares the current temperature values against the temperature thresholds. If any temperature is greater than or equal to a corresponding active trip point then OSPM will perform active cooling. If any temperature is greater than or equal to a corresponding passive trip point then OSPM will perform passive cooling. If the `_TMP` object returns a value greater than or equal to the value returned by the `_HOT` object then OSPM may choose to transition the system into the S4 sleeping state, if supported. If the `_TMP` object returns a value greater than or equal

to the value returned by the `_CRT` object then OSPM must shut the system down. Embedded Hot and Critical trip points may also be exposed by individual devices within a thermal zone. Upon passing of these trip points, OSPM must decide whether to shut down the device or the entire system based upon device criticality to system operation. OSPM must also evaluate the thermal zone's temperature interfaces when any thermal zone appears in the namespace (for example, during system initialization) and must initiate a cooling policy as warranted independent of receipt of a temperature change notification. This allows OSPM to cool systems containing a thermal zone whose temperature has already exceeded temperature thresholds at initialization time.

An optimally designed system that uses several thresholds can notify OSPM of thermal increase or decrease by raising an event every several degrees. This enables OSPM to anticipate thermal trends and incorporate heuristics to better manage the system's temperature.

To implement a preference towards performance or energy conservation, OSPM can request that the platform change the priority of active cooling (performance) versus passive cooling (energy conservation/silence) by evaluating the `_SCP` (Set Cooling Policy) object for the thermal zone or a corresponding OS-specific interface to individual devices within a thermal zone.

11.1.2 Dynamically Changing Cooling Temperature Trip Points

The platform or its devices can change the active and passive cooling temperature trip points and notify OSPM to reevaluate the trip point interfaces to establish the new policy threshold settings. The following are the primary uses for this type of thermal notification:

- When OSPM changes the platform's cooling policy from one cooling mode to another.
- When a swappable bay device is inserted or removed. A swappable bay is a slot that can accommodate several different devices that have identical form factors, such as a CD-ROM drive, disk drive, and so on. Many mobile PCs have this concept already in place.
- After the crossing of an active or passive trip point is signaled to implement hysteresis.

In each situation, OSPM must be notified to re-evaluate the thermal zone's trip points via the AML code execution of a `Notify(thermal_zone, 0x81)` statement or via an OS specific interface invoked by device drivers for zone devices participating in the thermal model.

11.1.2.1 OSPM Change of Cooling Policy

When OSPM changes the platform's cooling policy from one cooling mode to the other, the following occurs:

1. OSPM notifies the platform of the new cooling mode by running the Set Cooling Policy (`_SCP`) control method in all thermal zones and invoking the OS-specific Set Cooling Policy interface to all participating devices in each thermal zone.
2. Thresholds are updated in the hardware and OSPM is notified of the change.
3. OSPM re-evaluates the active and passive cooling temperature trip points for the zone and all devices in the zone to obtain the new temperature thresholds.

11.1.2.2 Resetting Cooling Temperatures to Adjust to Bay Device Insertion or Removal

The platform can adjust the thermal zone temperature to accommodate the maximum operating temperature of a bay device as necessary. For example:

1. Hardware detects that a device was inserted into or removed from the bay, updates the temperature thresholds, and then notifies OSPM of the thermal policy change and device insertion events.
2. OSPM re-enumerates the devices and re-evaluates the active and passive cooling temperature trip points.

11.1.2.3 Resetting Cooling Temperatures to Implement Hysteresis

An OEM can build hysteresis into platform thermal design by dynamically resetting cooling temperature thresholds. For example:

1. When the temperature increases to the designated threshold, OSPM will turn on the associated active cooling device or perform passive cooling.
2. The platform resets the threshold value to a lower temperature (to implement hysteresis) and notifies OSPM of the change. Because of this new threshold value, the fan will be turned off at a lower temperature than when it was turned on (therefore implementing a negative hysteresis).
3. When the temperature hits the lower threshold value, OSPM will turn off the associated active cooling device or cease passive cooling. The hardware will reset `_ACx` to its original value and notify OSPM that the trip points have once again been altered.

11.1.3 Detecting Temperature Changes

The ability of the platform and its devices to asynchronously notify an ACPI-compatible OS of meaningful changes in the thermal zone's temperature is a highly desirable capability that relieves OSPM from implementing a poll-based policy and generally results in a much more responsive and optimal thermal policy implementation. Each notification instructs OSPM to evaluate whether a trip point has been crossed and allows OSPM to anticipate temperature trends for the thermal zone.

It is recognized that much of the hardware used to implement thermal zone functionality today is not capable of generating ACPI-visible notifications (SCIs) or only can do so with wide granularity (for example, only when the temperature crosses the critical threshold). In these environments, OSPM must poll the thermal zone's temperature periodically to implement an effective policy.

While ACPI specifies a mechanism that enables OSPM to poll thermal zone temperature, platform reliance on thermal zone polling is strongly discouraged by this specification. OEMs should design systems that asynchronously notify OSPM whenever a meaningful change in the zone's temperature occurs - relieving OSPM of the overhead associated with polling. In some cases, embedded controller firmware can overcome limitations of existing thermal sensor capabilities to provide the desired asynchronous notification.

Notice that the `_TZP` (thermal zone polling) object is used to indicate whether a thermal zone must be polled by OSPM, and if so, a recommended polling frequency. See [_TZP \(Thermal Zone Polling\)](#) for more information.

11.1.3.1 Temperature Change Notifications

Thermal zone-wide temperature sensor hardware that supports asynchronous temperature change notifications does so using an SCI. The AML code that responds to this SCI must execute a `Notify(thermal_zone, 0x80)` statement to inform OSPM that a meaningful change in temperature has occurred. Alternatively, devices with embedded temperature sensors may signal their associated device drivers and the drivers may use an OS-specific interface to signal OSPM's thermal policy driver. A device driver may also invoke a device specific control method that executes a `Notify(thermal_zone, 0x80)` statement. When OSPM receives this thermal notification, it will evaluate the thermal zone's temperature interfaces to evaluate the current temperature values. OSPM will then compare the values to the corresponding cooling policy trip point values (either zone-wide or device-specific). If the temperature has crossed over any of the policy thresholds, then OSPM will actively or passively cool (or stop cooling) the system, or shut the system down entirely.

Both the number and granularity of thermal zone trip points are OEM-specific. However, it is important to notice that since OSPM can use heuristic knowledge to help cool the system, the more events OSPM receives the better understanding it will have of the system's thermal characteristic.

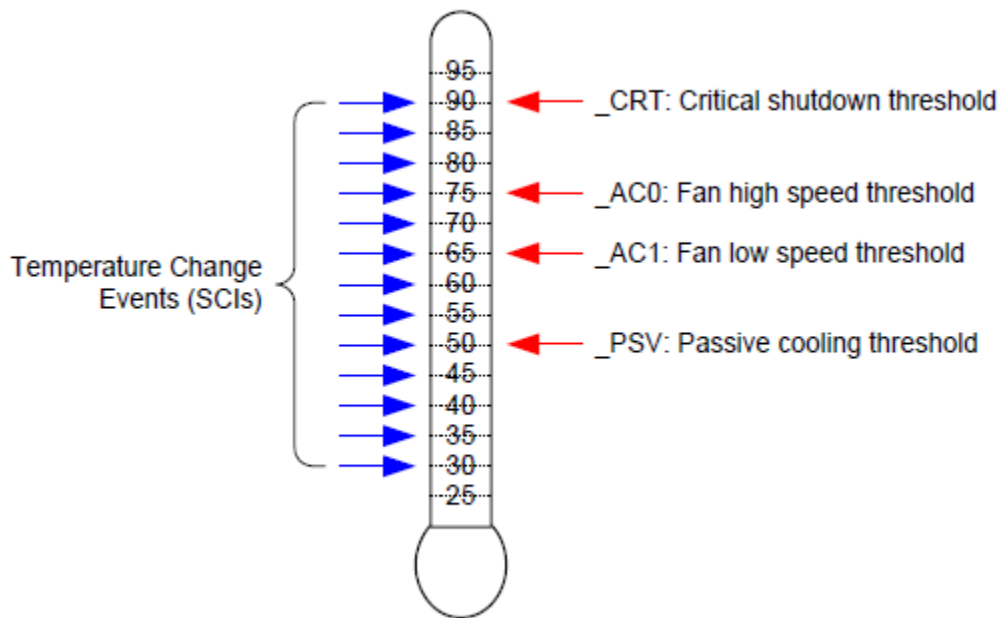

Fig. 11.2: Thermal Events

For example, the simple thermal zone illustrated above includes hardware that will generate a temperature change notification using a 5° Celsius granularity. All thresholds (`_PSV`, `_AC1`, `_AC0`, and `_CRT`) exist within the monitored range and fall on 5 boundaries. This granularity is appropriate for this system as it provides sufficient opportunity for OSPM to detect when a threshold is crossed as well as to understand the thermal zone's basic characteristics (temperature trends).

Note: The ACPI specification defines Kelvin as the standard unit for absolute temperature values. All thermal zone objects must report temperatures in Kelvin when reporting absolute temperature values. All figures and examples in this section of the specification use Celsius for reasons of clarity. ACPI allows Kelvin to be declared in precision of 1/10th of a degree (for example, 310.5).

Kelvin is expressed as follows:

$$\theta/K = T/(\text{degreesCelsius}) + 273.2$$

11.1.3.2 Polling

Temperature sensor hardware that is incapable of generating thermal change events, or that can do so for only a few thresholds should inform OSPM to implement a poll-based policy. OSPM does this to ensure that temperature changes across threshold boundaries are always detectable.

Polling can be done in conjunction with hardware notifications. For example, thermal zone hardware that only supports a single threshold might be configured to use this threshold as the critical temperature trip point. Assuming that hardware monitors the temperature at a finer granularity than OSPM would, this environment has the benefit of being more responsive when the system is overheating.

A thermal zone advertises the need to be polled by OSPM via the `_TZP` object. See *`_TZP (Thermal Zone Polling)`* for more information.

11.1.4 Active Cooling

Active cooling devices typically consume power and produce some amount of noise when enabled. These devices attempt to cool a thermal zone through the removal of heat rather than limiting the performance of a device to address an adverse thermal condition.

The active cooling interfaces in conjunction with the active cooling lists or the active cooling relationship table (`_ART`) allow the platform to use an active device that offers varying degrees of cooling capability or multiple cooling devices. The active cooling temperature trip points designate the temperature where Active cooling is engaged or disengaged (depending upon the direction in which the temperature is changing). For thermal zone-wide active cooling controls, the `_ALx` object evaluates to a list of devices that actively cool the zone or the `_ART` object evaluates to describe the entire active cooling relationship of various devices. For example:

- If a standard single-speed fan is the Active cooling device, then `_AC0` evaluates to the temperature where active cooling is engaged and the fan is listed in `_AL0`.
- If the zone uses two independently controlled single-speed fans to regulate the temperature, then `_AC0` will evaluate to the maximum cooling temperature using two fans, and `_AC1` will evaluate to the standard cooling temperature using one fan.
- If a zone has a single fan with a low speed and a high speed, the `_AC0` will evaluate to the temperature associated with running the fan at high-speed, and `_AC1` will evaluate to the temperature associated with running the fan at low speed. `_AL0` and `_AL1` will both point to different device objects associated with the same physical fan, but control the fan at different speeds.
- If the zone uses two independently controlled multiple-speed fans to regulate the temperature, `_AC0` of the target devices evaluates to the temperature at which OSPM will engage fan devices described by the `_ART` object as needed up to a maximum capability level.

For ASL coding examples that illustrate these points, see *Thermal Zone Interface Requirements* and *Thermal Zone Examples*.

11.1.5 Passive Cooling

Passive cooling controls are able to cool a thermal zone without creating noise and without consuming additional power (actually saving power), but do so by decreasing the performance of the devices in the zone .

11.1.5.1 Processor Clock Throttling

The processor passive cooling threshold (`_PSV`) in conjunction with the processor list (`_PSL`) allows the platform to indicate the temperature at which a passive control, for example clock throttling, will be applied to the processor(s) residing in a given thermal zone. Unlike other cooling policies, during passive cooling of processors OSPM may take the initiative to actively monitor the temperature in order to cool the platform.

On an ACPI-compatible platform that properly implements CPU throttling, the temperature transitions will be similar to the following figure, in a coolable environment, running a coolable workload:

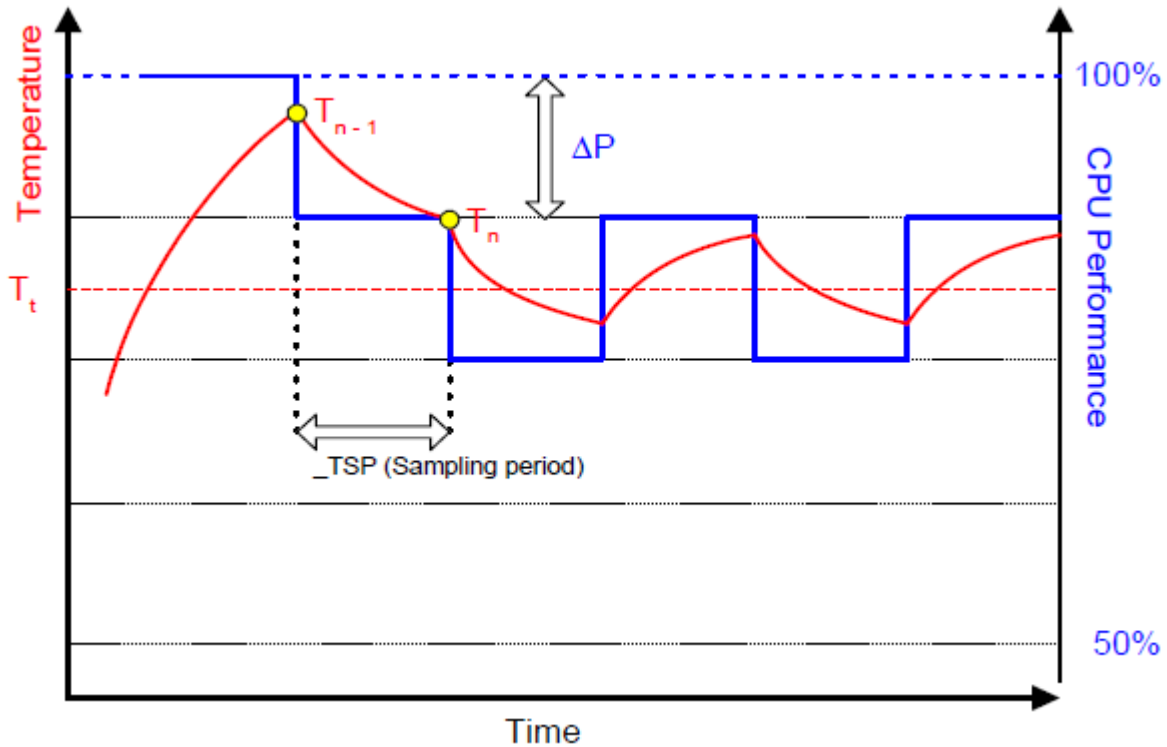

Fig. 11.3: Temperature and CPU Performance Versus Time

The following equation should be used by OSPM to assess the optimum CPU performance change necessary to lower the thermal zone's temperature:

Equation #1

$$\Delta P[\%] = _TC1 * (T_n - T_{n-1}) + _TC2 * (T_n - T_t)$$

Where:

T_n = current temperature

T_t = target temperature (`_PSV`)

The two coefficients `_TC1` and `_TC2` and the sampling period `_TSP` are hardware-dependent constants the OEM must supply to OSPM (for more information, see [Section 11.4](#)). The `_TSP` object contains a time interval that OSPM uses to poll the hardware to sample the temperature. Whenever the time value returned by `_TSP` has elapsed, OSPM will evaluate `_TMP` to sample the current temperature (shown as T_n in the above equation). Then OSPM will use the

sampled temperature and the passive cooling temperature trip point ($_PSV$) (which is the target temperature T_t) to evaluate the equation for ΔP . The granularity of ΔP is determined by the CPU duty width of the system.

Note: Equation #1 has an implied formula.

Equation #2:

$$P_n = P_{n-1} + HW[-\Delta P]$$

where:

$$\text{Minimum}\% \leq P_n \leq 100\%$$

For this equation, whenever $P_{n-1} + \Delta P$ lies outside the range Minimum0-100%, then P_n will be truncated to Minimum0-100%. Minimum% is the $_MTL$ limit, or 0% if $_MTL$ is not defined. For hardware that cannot assume all possible values of P_n between Minimum0 and 100%, a hardware specific mapping function HW is used.

In addition, the hardware mapping function in Equation #2 should be interpreted as follows.

For absolute temperatures:

1. If the right hand side of Equation #1 is negative, $HW[\Delta P]$ is rounded to the next available higher setting of frequency.
2. If the right hand side of Equation #1 is positive, $HW[\Delta P]$ is rounded to the next available lower setting of frequency.

For relative temperatures:

1. If the right hand side of Equation #1 is positive, $HW[\Delta P]$ is rounded to the next available higher setting of frequency.
2. If the right hand side of Equation #1 is negative, $HW[\Delta P]$ is rounded to the next available lower setting of frequency.
 - The calculated P_n becomes P_{n-1} during the next sampling period.
 - For more information about CPU throttling, see *Processor Power State C0*. A detailed explanation of this thermal feedback equation is beyond the scope of this specification.

11.1.6 Critical Shutdown

When the thermal zone-wide temperature sensor value reaches the threshold indicated by $_CRT$, OSPM must immediately shut the system down. The system must disable the power either after the temperature reaches some hardware-determined level above $_CRT$ or after a predetermined time has passed. Before disabling power, platform designers should incorporate some time that allows OSPM to run its critical shutdown operation. There is no requirement for a minimum shutdown operation window that commences immediately after the temperature reaches $_CRT$. This is because:

- Temperature might rise rapidly in some systems and slowly on others, depending on casing design and environmental factors.
- Shutdown can take several minutes on a server and only a few seconds on a hand-held device.

Because of this indistinct discrepancy and the fact that a critical heat situation is a remarkably rare occurrence, ACPI does not specify a target window for a safe shutdown. It is entirely up to the OEM to build in a safe buffer that it sees fit for the target platform.

11.2 Cooling Preferences

A robust OSPM implementation provides the means for the end user to convey a preference (or a level of preference) for either performance or energy conservation to OSPM. Allowing the end user to choose this preference is most critical to mobile system users where maximizing system run-time on a battery charge often has higher priority over realizing maximum system performance. For example, if a user is taking notes on her PC in a quiet environment, such as a library or a corporate meeting, she may want the system to emphasize passive cooling so that the system operates quietly, even at the cost of system performance.

A user preference towards performance corresponds to the Active cooling mode while a user's preference towards energy conservation or quiet corresponds to the Passive cooling mode. ACPI defines an interface to convey the cooling mode to the platform. Active cooling can be performed with minimal OSPM thermal policy intervention. For example, the platform indicates through thermal zone parameters that crossing a thermal trip point requires a fan to be turned on. Passive cooling requires OSPM thermal policy to manipulate device interfaces that reduce performance to reduce thermal zone temperature.

Either cooling mode will be activated only when the thermal condition requires it. When the thermal zone is at an optimal temperature level where it does not warrant any cooling, both modes result in a system operating at its maximum potential with all fans turned off.

Thermal zones supporting the Set Cooling Policy interface allow the user to switch the system's cooling mode emphasis. See *_SCP (Set Cooling Policy)* for more information.

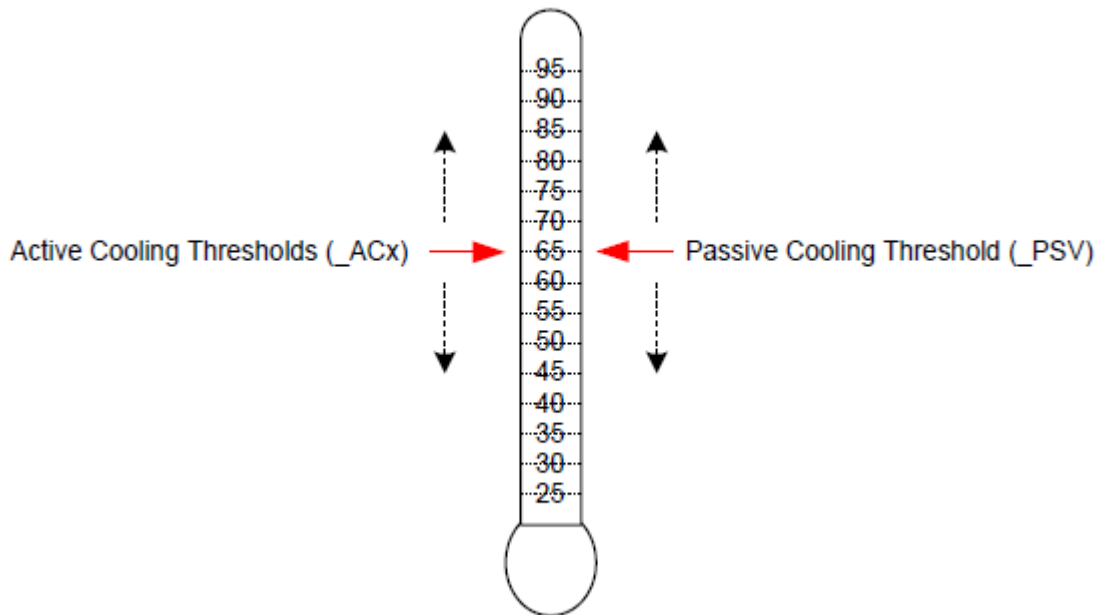

Fig. 11.4: Active and Passive Threshold Values

As illustrated in *Active and Passive Threshold Values*, the platform must convey the value for each threshold to instruct OSPM to initiate the cooling policies at the desired target temperatures. The platform can emphasize active or passive cooling modes by assigning different threshold values. Generally, if `_ACx` is set lower than `_PSV`, then the system emphasizes active cooling. Conversely, if `_PSV` is set lower than `_ACx`, then the emphasis is placed on passive cooling.

For example, a thermal zone that includes a processor and one single-speed fan may use `_PSV` to indicate the temperature value at which OSPM would enable passive cooling and `_AC0` to indicate the temperature at which the fan would be turned on. If the value of `_PSV` is less than `_AC0` then the system will favor passive cooling (for example, CPU clock throttling). On the other hand, if `_AC0` is less than `_PSV` the system will favor active cooling (in other words, using the fan). See the figure below for more details.

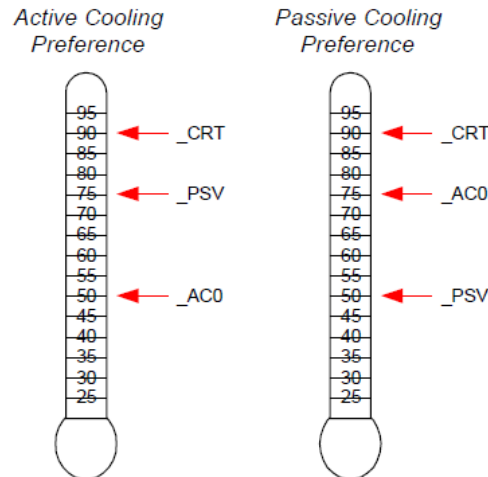

Fig. 11.5: Cooling Preferences

The example on the left enables active cooling (for example, turn on a fan) when OSPM detects the temperature has risen above 50°. If for some reason the fan does not reduce the system temperature, then at 75° OSPM will initiate passive cooling (for example, CPU throttling) while still running the fan. If the temperature continues to climb, OSPM will quickly shut the system down when the temperature reaches 90°C. The example on the right is similar but the _AC0 and _PSV threshold values have been swapped to emphasize passive cooling.

The ACPI thermal model allows flexibility in the thermal zone design. An OEM that needs a less elaborate thermal implementation may consider using only a single threshold (for example, _CRT). Complex thermal implementations can be modeled using multiple active cooling thresholds and devices, or through the use of additional thermal zones.

11.2.1 Evaluating Thermal Device Lists

The Notify(thermal_zone, 0x82) statement is used to inform OSPM that a change has been made to the thermal zone device lists. This thermal event instructs OSPM to re-evaluate the _ALx, _PSL, and _TZD objects.

For example, a system that supports the dynamic insertions of processors might issue this notification to inform OSPM of changes to _PSL following the insertion or removal of a processor. OSPM would re-evaluate all thermal device lists and adjust its policy accordingly.

Notice that this notification can be used with the Notify(thermal_zone, 0x81) statement to inform OSPM to both re-evaluate all device lists and all thresholds.

Alternatively, devices may include the _TZM (Thermal Zone Member) object their device scope to convey their thermal zone association to OSPM. See [_TZM \(Thermal Zone Member\)](#) below for more information.

11.2.2 Evaluating Device Thermal Relationship Information

The Notify(thermal_zone, 0x83) statement is used to inform OSPM that a change has been made to the thermal relationship information. This thermal event instructs OSPM to re-evaluate the _TRT and _ART objects. The thermal influence between devices may change when active cooling moves air across device packages as compared to when only passive cooling controls are applied. Similarly, the active cooling relationship may change as various fans are engaged to actively cool a platform or if user preferences change.

11.2.3 Fan Device Notifications

Notify events of type 0x80 will cause OSPM to evaluate the `_FST` object to evaluate the fan's current speed.

11.3 Fan Device

ACPI 1.0 defined a simple fan device that is assumed to be in operation when it is in the D0 state. Thermal zones reference fan device(s) as being responsible primarily for cooling within that zone. Notice that multiple fan devices can be present for any one thermal zone. They might be actual different fans, or they might be used to implement one fan of multiple speeds (for example, by turning both “fans” on the one fan will run full speed).

ACPI 4.0 defines additional fan device interface objects enabling OSPM to perform more robust active cooling thermal control. These objects are summarized (see [Table 11.1](#) below). OSPM requires that all of the objects listed in the table below be defined under a fan device to enable advanced active cooling control. The absence of any of these objects causes OSPM to perform ACPI 1.0 style simple fan control .

The Plug and Play ID of a fan device is PNP0C0B.

Table 11.1: Fan Specific Objects

Object	Description
<code>_FIF</code>	Returns fan device information.
<code>_FPS</code>	Returns a list of supported fan performance states.
<code>_FSL</code>	Control method that sets the fan device's speed level (performance state).
<code>_FST</code>	Returns current status information for a fan device.

While the Fan Device and its associated objects are optional, if the Fan Device is implemented by the platform, all objects listed in the table above are required and must be provided.

11.3.1 Fan Objects

11.3.1.1 `_FIF` (Fan Information)

The optional `_FIF` object provides OSPM with fan device capability information.

Arguments:

None

Return Value:

A Package containing the fan device parameters as described in the table below

`_FIF` evaluation returns a package of the following format:

```
Package () {
    Revision,                // Integer
    FineGrainControl,       // Integer Boolean
    StepSize                 // Integer DWORD
    LowSpeedNotificationSupport // Integer Boolean
}
```

Table 11.2: FIF Package Details

Field	Format	Description
Revision	Integer	Current revision is: 0
Fine Grain Control	Integer (Boolean)	A non zero value in this field indicates OSPM may evaluate the fan device's _FSL object with a Level argument value in the range of 0-100, which represents a percentage of maximum speed. A zero value in this field indicates that OSPM may evaluate the fan device's _FSL object with a Level argument value that is a Control field value from a package in the _FPS object's package list only.
Step Size	Integer (DWORD)	The recommended minimum step size in percentage points to be used when OSPM performs fine-grained fan speed control. OSPM may utilize the value of this field if the FineGrainControl field is non-zero the value in this field is between 1 and 9.
Low Speed Notification Support	Integer (Boolean)	A non zero value in this field indicates that the platform will issue a Notify (0x80) to the fan device if a low (errant) fan speed is detected.

If a fan device supports fine-grained control, OSPM may evaluate a fan device's _FSL object with any Level argument value that is less than or equal to the Control field value specified in the package of the _FPS object's package list that corresponds to the active cooling trip point that has been exceeded. This capability provides OSPM access to one hundred fan speed settings thus enabling fine-grained fan speed control. The platform uses the StepSize field to help OSPM optimize its fan level selection policy by fine-grained fan speed control. The platform uses the StepSize field to help OSPM optimize its fan level selection policy by indicating recommended increments in the fan speed level value that are appropriate for the fan when one percent increments are not optimal. In the event OSPM's incremental selections of Level using the StepSize field value do not sum to 100%, OSPM may select an appropriate ending Level increment to reach 100%. OSPM should use the same residual step value first when reducing Level.

11.3.1.2 _FPS (Fan Performance States)

The optional _FPS object evaluates to a variable-length package containing a list of packages that describe the fan device's performance states. A temperature reading above an active cooling trip point defined by an _ACx object in a thermal zone or above a native active cooling trip point of a device within the thermal zone causes OSPM thermal control to engage the appropriate corresponding fan performance state from the list of fan performance states described by the _FPS object if the fan device is present in the corresponding _ALx device list or if an entry exists for the fan and trip point in the active cooling relationship table (_ART).

OSPM assumes a linear relationship for the acoustic impact and power consumption values between successive entries in the fan performance state list. Notice that the acoustic impact measurement unit (Decibels) is inherently non-linear. As such, the platform should populate _FPS entries as necessary to enable OSPM to achieve optimal results.

Arguments:

None

Return Value:

A variable-length Package containing a Revision ID and a list of Packages that describe the fan device's performance states as described in the table below.

Return Value Information

```
Package {
    Revision,                // Integer - Current revision is: 0
    FanPState[0],          // Package
    ....
```

(continues on next page)

(continued from previous page)

```
FanPState[n]          // Package
}

```

Each FanPState sub-Package contains the elements described below:

```
Package ()           // Fan P-State
{
    Control,          // Integer DWORD
    TripPoint,        // Integer DWORD
    Speed,            // Integer DWORD
    NoiseLevel,       // Integer DWORD
    Power             // Integer DWORD
}

```

Table 11.3: FPS FanPstate Package Details

Field	Format	Description
Control	Integer (DWORD)	Indicates the value to be used to set the fan speed to a specific level using the <code>_FSL</code> object. If the fan device supports fine-grained control as indicated by the <code>_FIF</code> object, this value is a percentage (0-100) of maximum speed level. If the fan device does not support fine-grained control, this field is an opaque value that OSPM must simply use in its evaluation of the <code>_FSL</code> object to set the level to this performance state.
TripPoint	Integer (DWORD)	0-9: The active cooling trip point number that corresponds to this performance state. If the <code>_ART</code> object is defined, OSPM may optionally use information provided by the <code>_ART</code> object and <code>_FPS</code> objects to select alternative fan performance states. Only one entry per unique trip point number is allowed in the <code>_FPS</code> . 0x0A-0xFFFFFFFF: Reserved 0xFFFFFFFF: Indicates that this performance state does not correspond with a specific active cooling trip point.
Speed	Integer (DWORD)	Indicates the speed of the fan in revolutions per minute in this performance state.
NoiseLevel	Integer (DWORD)	This optional field indicates the audible noise emitted by the fan in this performance state. The value represents the noise in 10ths of decibels. For example, if the fan emits noise at 28.3dB in this performance state, the value of this field would be 283. A value of 0xFFFFFFFF indicates that this field is not populated.
Power	Integer (DWORD)	This optional field indicates the power consumption (in milliwatts) of the fan in this performance state. For example, if the fan consumes .5W in this performance state, the value of this field would be 500. A value of 0xFFFFFFFF indicates that this field is not populated.

11.3.1.3 _FSL (Fan Set Level)

The optional _FSL object is a control method that OSPM evaluates to set a fan device’s speed (performance state) to a specific level

Arguments:(1)

Arg0 - Level (Integer): conveys to the platform the fan speed level to be set.

Return Value:

None

Argument Information

Arg0: Level. If the fan supports fine-grained control, Level is a percentage of maximum level (0-100) that the platform is to engage the fan. If the fan does not support fine-grained control, Level is a Control field value from a package in the _FPS object’s package list. A Level value of zero causes the platform to turn off the fan.

11.3.1.4 _FST (Fan Status)

The optional _FST object provides status information for the fan device.

Arguments:

None

Return Value:

A Package containing fan device status information as described in the table below

_FST evaluation returns a package of the following format:

```
Package () {
    Revision,           // Integer
    Control,           // Integer DWORD
    Speed              // Integer DWORD
}
```

Table 11.4: FST Package Details

Field	Format	Description
Revision	Integer	Current revision is: 0
Control	Integer (DWORD)	The current control value used to operate the Fan. If the fan is not operating Control will be zero. If the fan is operating, Control is the Level argument passed in the evaluation of the _FSL object.
Speed	Integer (DWORD)	The current fan speed in revolutions per minute at which the fan is rotating. A value of 0xFFFFFFFF indicates that the fan does not support speed reporting.

11.4 Thermal Objects

Objects related to thermal management are listed in the following table.

Table 11.5: Thermal Objects

Object	Description
_ACx	Returns active cooling policy threshold values in tenths of degrees.
_ALx	List of active cooling device objects.
_ART	Table of values that convey the Active Cooling Relationship between devices
_CRT	Returns critical trip point in tenths of degrees where OSPM must perform a critical shutdown.
_HOT	Returns critical trip point in tenths of degrees where OSPM may choose to transition the system into S4.
_MTL	Returns the minimum throttle limit of a zone, when defined under a thermal zone. T
_NTT	Returns the temperature change threshold for devices containing native temperature sensors to cause evaluation of the _TPT object
_PSL	List of processor device objects for clock throttling.
_PSV	Returns the passive cooling policy threshold value in tenths of degrees.
_RTV	Conveys whether temperatures are expressed in terms of absolute or relative values.
_SCP	Sets platform cooling policy (active or passive).
_STR	String name for this thermal zone.
_TC1	Thermal constant for passive cooling.
_TC2	Thermal constant for passive cooling.
_TFP	Thermal fast sampling period for Passive cooling in milliseconds.
_TMP	Returns the thermal zone's current temperature in tenths of degrees.
_TPT	Conveys the temperature of a devices internal temperature sensor to the platform when a temperature trip point is crossed or a meaningful change in temperature occurs.
_TRT	Table of values that convey the Thermal Relationship between devices
_TSN	Returns a reference to the thermal sensor device used to monitor the temperature of the thermal zone (when defined under a thermal zone).
_TSP	Thermal sampling period for Passive cooling in tenths of seconds.
_TST	Conveys the minimum separation for a devices' programmable temperature trip points.
_TZD	List of devices whose temperature is measured by this thermal zone.
_TZM	Returns the thermal zone for which a device is a member.
_TZP	Thermal zone polling frequency in tenths of seconds.

With the exception of _TPT, _TST, and the _TZM objects, the objects described in the following sections may exist under a thermal zone. Devices with embedded thermal sensors and controls may contain static cooling temperature trip points or dynamic cooling temperature trip points that must be programmed by the device's driver. In this case, thermal objects defined under a device serve to convey the platform specific values for these settings to the devices driver.

11.4.1 _ACx (Active Cooling)

This optional object, if present under a thermal zone, returns the temperature trip point at which OSPM must start or stop Active cooling, where x is a value between 0 and 9 that designates multiple active cooling levels of the thermal zone. If the Active cooling device has one cooling level (that is, "on") then that cooling level must be defined as _AC0. If the cooling device has two levels of capability, such as a high fan speed and a low fan speed, then they must be defined as _AC0 and _AC1 respectively. The smaller the value of x, the greater the cooling strength _ACx represents. In the above example, _AC0 represents the greater level of cooling (the faster fan speed) and _AC1 represents the lesser level of cooling (the slower fan speed). For every _ACx method, there must be a matching _ALx object or a corresponding entry in an _ART object's active cooling relationship list.

If this object is present under a device, the device's driver evaluates this object to determine the device's corresponding active cooling temperature trip point. This value may then be used by the device's driver to program an internal device temperature sensor trip point. When this object is present under a device, the device must contain a native OS device driver interface supporting a corresponding active cooling control, a matching `_ALx` object under the thermal zone of which the device is a member must exist, or a corresponding entry in an `_ART` object's active cooling relationship list must.

Arguments:

None

Return Value:

An Integer containing the active cooling temperature threshold in tenths of degrees Kelvin

The return value is an integer that represents tenths of degrees Kelvin. For example, 300.0K is represented by the integer 3000.

11.4.2 `_ALx` (Active List)

This object is defined under a thermal zone and evaluates to a list of Active cooling devices to be turned on when the corresponding `_ACx` temperature threshold is exceeded. For example, these devices could be fans.

Arguments:

None

Return Value:

A variable-length Package containing a list of References to active cooling devices

The return value is a package consisting of references to all active cooling devices that should be engaged when the associated active cooling threshold (`_ACx`) is exceeded.

When the returned package consists of references to an active cooling device that is a fan device and the fan device implements `_FPS` and `_FSL` objects, OSPM activates the identified fan at a capability level matching the level identified by this object. For example, if the system has a fan that implements `_FPS` object with 5 levels, and if `_AL3` is evaluated by the OSPM causing it to return this fan's reference, then the fan is activated by evaluating `_FSL` with the value from the Control field of an `_FPS` entry whose TripPoint field value equals 3.

If a thermal zone has the `_ART` object defined, then it is not necessary to have any `_ALx` objects implemented.

Note: If a thermal zone has `_ART` object defined as well as `_ALx` defined, the OSPM ignores `_ALx` objects and uses `_ART` exclusively.

11.4.3 `_ART` (Active Cooling Relationship Table)

The optional `_ART` object evaluates to a variable-length package containing a list of packages each of which describes the active cooling relationship between a device within a thermal zone and an active cooling device. OSPM uses the combined information about the active cooling relationships of all devices in the thermal zone to make active cooling policy decisions.

If `_ART` is implemented within a thermal zone, OSPM ignores all `_ALx` objects as `_ART` conveys a mapping for each of the `_ACx` trip points to active cooling devices.

The platform can dynamically change the `_ART` object by notifying the thermal zone object with a Notify code of 0x83, which will cause OSPM to re-evaluate both the `_TRT` and `_ART` objects. This allows the platform to change the capability level mapping to various `_ACx` trip points dynamically at run time.

Arguments:

None

Return Value:

A variable-length Package containing a Revision ID and a list of Active Relationship Packages as described below:

Return Value Information

```
Package {
    Revision,                // Integer - Current revision is: 0
    ActiveRelationship[0]   // Package
    ....
    ActiveRelationship[n]   // Package
}
```

Each ActiveRelationship sub-Package contains the elements described below:

```
Package {
    SourceDevice,           // Object Reference to a Fan Device Object
    TargetDevice,          // Object Reference to a Device Object
    Weight,                 // Integer
    AC0MaxLevel,           // Integer
    AC1MaxLevel,           // Integer
    AC2MaxLevel,           // Integer
    AC3MaxLevel,           // Integer
    AC4MaxLevel,           // Integer
    AC5MaxLevel,           // Integer
    AC6MaxLevel,           // Integer
    AC7MaxLevel,           // Integer
    AC8MaxLevel,           // Integer
    AC9MaxLevel            // Integer
}
```

Table 11.6: Thermal Relationship Package Values 1

Element	Object Type	Description
SourceDevice	Reference (to a device)	The fan device that has an impact on the cooling of the device indicated by TargetDevice.
TargetDevice	Reference (to a device)	The device that is impacted by the fan device indicated by SourceDevice.
Weight	Integer	Indicates the SourceDevice’s contribution to the platform’s Target-Device total cooling capability when the fans of all entries in the _ART with the same target device are engaged at their highest (maximum capability) performance state. This is represented as a percentage value (0-100).
AC0MaxLevel	Integer (DWORD)	Indicates the maximum fans speed level in percent (0-100) that OSPM may engage on the SourceDevice when a temperature exceeds the _AC0 trip point value. A value of 0xFFFFFFFF in this field indicates that the SourceDevice is not to be engaged for the trip point.

continues on next page

Table 11.6 – continued from previous page

Element	Object Type	Description
AC1MaxLevel	Integer (DWORD)	Indicates the maximum fans speed level in percent (0-100) that OSPM may engage on the SourceDevice when a temperature exceeds the _AC1 trip point value. A value of 0xFFFFFFFF in this field indicates that the SourceDevice is not to be engaged for the trip point.
AC2MaxLevel	Integer (DWORD)	Indicates the maximum fans speed level in percent (0-100) that OSPM may engage on the SourceDevice when a temperature exceeds the _AC2 trip point value. A value of 0xFFFFFFFF in this field indicates that the SourceDevice is not to be engaged for the trip point.
AC3MaxLevel	Integer (DWORD)	Indicates the maximum fans speed level in percent (0-100) that OSPM may engage on the SourceDevice when a temperature exceeds the _AC3 trip point value. A value of 0xFFFFFFFF in this field indicates that the SourceDevice is not to be engaged for the trip point.
AC4MaxLevel	Integer (DWORD)	Indicates the maximum fans speed level in percent (0-100) that OSPM may engage on the SourceDevice when a temperature exceeds the _AC4 trip point value. A value of 0xFFFFFFFF in this field indicates that the SourceDevice is not to be engaged for the trip point.
AC5MaxLevel	Integer (DWORD)	Indicates the maximum fans speed level in percent (0-100) that OSPM may engage on the SourceDevice when a temperature exceeds the _AC5 trip point value. A value of 0xFFFFFFFF in this field indicates that the SourceDevice is not to be engaged for the trip point.
AC6MaxLevel	Integer (DWORD)	Indicates the maximum fans speed level in percent (0-100) that OSPM may engage on the SourceDevice when a temperature exceeds the _AC6 trip point value. A value of 0xFFFFFFFF in this field indicates that the SourceDevice is not to be engaged for the trip point.
AC7MaxLevel	Integer (DWORD)	Indicates the maximum fans speed level in percent (0-100) that OSPM may engage on the SourceDevice when a temperature exceeds the _AC7 trip point value. A value of 0xFFFFFFFF in this field indicates that the SourceDevice is not to be engaged for the trip point.
AC8MaxLevel	Integer (DWORD)	Indicates the maximum fans speed level in percent (0-100) that OSPM may engage on the SourceDevice when a temperature exceeds the _AC8 trip point value. A value of 0xFFFFFFFF in this field indicates that the SourceDevice is not to be engaged for the trip point.
AC9MaxLevel	Integer (DWORD)	Indicates the maximum fans speed level in percent (0-100) that OSPM may engage on the SourceDevice when a temperature exceeds the _AC9 trip point value. A value of 0xFFFFFFFF in this field indicates that the SourceDevice is not to be engaged for the trip point.

In the case multiple active cooling trip points have been exceeded and _ART entries indicate various maximum limits for the same SourceDevice, OSPM may operate the SourceDevice up to the highest ACxMaxLevel value indicated for all exceeded trip points.

11.4.4 _CRT (Critical Temperature)

This object, when defined under a thermal zone, returns the critical temperature at which OSPM must shutdown the system. If this object is present under a device, the device's driver evaluates this object to determine the device's critical cooling temperature trip point. This value may then be used by the device's driver to program an internal device temperature sensor trip point.

Arguments:

None

Return Value:

An Integer containing the critical temperature threshold in tenths of degrees Kelvin

The result is an integer value that represents the critical shutdown threshold in tenths of degrees. For example, 300.0K is represented by the integer 3000.

11.4.5 _CR3 (Warm/Standby Temperature)

This object, when defined under a thermal zone, returns the critical temperature at which OSPM may choose to transition the system into a low power state with a faster exit latency than S4 sleeping state (e.g. S3, or an equivalent low power state if the LOW_POWER_S0_IDLE_CAPABLE FADT flag is set). The platform vendor should define _CR3 to be sufficiently below _CRT so as to allow enough time to transition the system into this low power state. It may be sufficient to define either _CR3 or _HOT depending on the type and thermal characteristics of the specific thermal zone under consideration. If this object is present under a device, the device's driver evaluates this object to determine the device's warm/standby cooling temperature trip point. This value may then be used by the device's driver to program an internal device temperature sensor trip point.

Arguments:

None

Return Value:

An Integer containing the critical temperature threshold in tenths of degrees Kelvin

The result is an integer value that represents the critical shutdown threshold in tenths of degrees. For example, 300.0K is represented by the integer 3000.

11.4.6 _DTI (Device Temperature Indication)

This optional object may be present under a device and is evaluated by OSPM when the device's native (driver managed) temperature sensor has crossed a cooling temperature trip point or when a meaningful change in temperature (as indicated by evaluation of the _NTT object) has occurred. OSPM evaluation of the _DTI object enables the platform to take action as a result of these events. For example, the platform may choose to implement fan control hysteresis based on the conveyed value or signal the reevaluation of the _TDL or _PDL objects.

Arguments:(1)

Arg0 - An Integer containing the current value of the temperature sensor (in tenths Kelvin)

Return Value:

None

11.4.7 **_HOT (Hot Temperature)**

This optional object, when defined under a thermal zone, returns the critical temperature at which OSPM may choose to transition the system into the S4 sleeping state. The platform vendor should define `_HOT` to be far enough below `_CRT` so as to allow OSPM enough time to transition the system into the S4 sleeping state. While dependent on the amount of installed memory, on typical platforms OSPM implementations can transition the system into the S4 sleeping state in tens of seconds. If this object is present under a device, the device's driver evaluates this object to determine the device's hot cooling temperature trip point. This value may then be used by the device's driver to program an internal device temperature sensor trip point.

Arguments:

None

Return Value:

An Integer containing the critical temperature threshold in tenths of degrees Kelvin

The return value is an integer that represents the critical sleep threshold tenths of degrees Kelvin. For example, 300.0K is represented by the integer 3000.

11.4.8 **_MTL (Minimum Throttle Limit)**

This object, when defined under a thermal zone, returns the minimum throttle limit of a zone. This will determine how much a thermal zone limits the performance of its controlled devices. This value can be used by OSPM to calculate the changes in performance limits it applies to the devices of the thermal zone.

Arguments:

None

Return Value:

An Integer value with the current minimum throttle limit, expressed as a percentage

11.4.9 **_NTT (Notification Temperature Threshold)**

This optional object may be defined under devices containing native temperature sensors and evaluates to the temperature change threshold for the device where the platform requires notification of the change via evaluation of the `_TPT` object.

Arguments:

None

Return Value:

An Integer containing the temperature threshold in tenths of degrees Kelvin.

The return value is an integer that represents the amount of change in device temperature that is meaningful to the platform and for which the platform requires notification via evaluation of the `_TPT` object.

11.4.10 _PSL (Passive List)

This object is defined under a thermal zone and evaluates to a list of processor objects to be used for passive cooling.

Arguments:

None

Return Value:

A variable-length Package containing a list of References to processor objects

The return value is a package consisting of references to all processor objects that will be used for passive cooling when the zone's passive cooling threshold (_PSV) is exceeded.

11.4.11 _PSV (Passive)

This optional object, if present under a thermal zone, evaluates to the temperature at which OSPM must activate passive cooling policy.

Arguments:

None

Return Value:

An Integer containing the passive cooling temperature threshold in tenths of degrees Kelvin

The return value is an integer that represents tenths of degrees Kelvin. For example, 300.0 Kelvin is represented by 3000.

If this object is present under a device, the device's driver evaluates this object to determine the device's corresponding passive cooling temperature trip point. This value may then be used by the device's driver to program an internal device temperature sensor trip point. When this object is present under a device, the device must contain a native OS device driver interface supporting a passive cooling control.

11.4.12 _RTV (Relative Temperature Values)

This optional object may be present under a device or a thermal zone and is evaluated by OSPM to determine whether the values returned by temperature trip point and current operating temperature interfaces under the corresponding device or thermal zone represent absolute or relative temperature values.

Arguments:

None

Return Value:

An Integer containing a relative versus absolute indicator:

0 Temperatures are absolute Other Temperatures are relative

The return value is an integer that indicates whether values returned by temperature trip point and current operating temperature interfaces represent absolute or relative temperature values.

If the _RTV object is not present or is present and evaluates to zero then OSPM assumes that all values returned by temperature trip point and current operating temperature interfaces under the device or thermal zone represent absolute temperature values expressed in tenths of degrees Kelvin.

If the _RTV object is present and evaluates to a non zero value then all values returned by temperature trip point and current operating temperature interfaces under the corresponding device or thermal zone represent temperature values relative to a zero point that is defined as the maximum value of the device's or thermal zone's critical cooling

temperature trip point. In this case, temperature trip point and current operating temperature interfaces return values in units that are tenths of degrees below the zero point.

OSPM evaluates the `_RTV` object before evaluating any other temperature trip point or current operating temperature interfaces.

11.4.13 `_SCP` (Set Cooling Policy)

This optional object is a control method that OSPM invokes to set the platform's cooling mode policy setting. The platform may use the evaluation of `_SCP` to reassign `_ACx` and `_PSV` temperature trip points according to the mode or limits conveyed by OSPM. OSPM will automatically evaluate `_ACx` and `_PSV` objects after executing `_SCP`. This object may exist under a thermal zone or a device.

Arguments:(3)

Arg0 - *Mode* An Integer containing the cooling mode policy code

Arg1 - *AcousticLimit* An Integer containing the acoustic limit

Arg2 - *PowerLimit* An Integer containing the power limit

Return Value:

None

Argument Information:

Mode - 0 = Active, 1 = Passive

Acoustic Limit - Specifies the maximum acceptable acoustic level that active cooling devices may generate. Values are 1 to 5 where 1 means no acoustic tolerance and 5 means maximum acoustic tolerance.

Power Limit - Specifies the maximum acceptable power level that active cooling devices may consume. Values are from 1 to 5 where 1 means no power may be used to cool and 5 means maximum power may be used to cool.

Example:

```
// Fan Control is defined as follows:

//      Speed 1 (Fan is Off): Acoustic Limit 1, Power Limit 1, <= 64C
//      Speed 2: Acoustic Limit 2, Power Limit 2, 65C - 74C
//      Speed 3: Acoustic Limit 3, Power Limit 3, 75C - 84C
//      Speed 4: Acoustic Limit 4, Power Limit 4, 85C - 94C
//      Speed 5: Acoustic Limit 5, Power Limit 5, >= 95C

// _SCP Notifies the platform the current cooling mode.
// Arg0 = Mode
//      0 - Active cooling
//      1 - Passive cooling
// Arg1 = Acoustic Limit
//      1 = No acoustic tolerance
//      ...
//      5 = maximum acoustic tolerance
// Arg2 = Power Limit
//      1 = No power may be used to cool
//      ...
//      5 = maximum power may be used to cool

Method(_SCP, 3, Serialized)
{
```

(continues on next page)

(continued from previous page)

```

// Store the Cooling Mode in NVS and use as needed in
// the rest of the ASL Code.
Store(Arg0, CTYP)

// Set PSVT to account for a Legacy OS that does not pass
// in either the acoustic limit or Power Limit.
If(Arg0)
{
    Store(60,PSVT)
}
Else
{
    Store(97,PSVT)
}
If (CondRefOf (_OSI,Local0))
{
    If (\_OSI ("3.0 _SCP Extensions"))
    {
        // Determine Power Limit.
        //
        // NOTE1: PSVT = Passive Cooling Trip Point stored
        // in NVS in Celsius.
        //
        // NOTE2: 4 Active Cooling Trips Points correspond to 5
        // unique Power Limit regions and 5 unique acoustic limit
        // regions.

        //
        // NOTE3: This code will define Passive cooling so that
        // CPU throttling will be initiated within the Power Limit
        // Region passed in such that the next higher Power Limit
        // Region will not be reached.
        Switch(Arg2)
        {

            Case(1) // Power Limit = 1.
            {
                // Stay in Acoustic Limit 1.
                Store(60,PSVT) // Passive = 60C.
            }
            Case(2) // Power Limit = 2.
            {
                // Store Highest supported Acoustic Level
                // at this Power Limit (1 or 2).
                Store(70,PSVT)
                If(Lequal(Arg1,1))
                {
                    // Stay in Acoustic Level 1.
                    Store(60,PSVT)
                }
            }
            Case(3) // Power Limit = 3.
            {
                // Store Highest supported Acoustic Level
                // at this Power Limit (1, 2, or 3).
                Store(80,PSVT)
                If(Lequal(Arg1,2))

```

(continues on next page)

(continued from previous page)

```

    {
        // Stay in Acoustic Level 1 or 2.
        Store(70,PSVT)
    }
    If(Lequal(Arg1,1))
    {
        // Stay in Acoustic Level 1.
        Store(60,PSVT)
    }
}
Case(4) // Power Limit = 4.
{
    // Store Highest supported Acoustic Level
    // at this Power Limit (1, 2, 3, or 4).
    Store(90,PSVT)
    If(Lequal(Arg1,3))
    {
        // Stay in Acoustic Level 1 or 2.
        Store(80,PSVT)
    }
    If(Lequal(Arg1,2))
    {
        // Stay in Acoustic Level 1 or 2.
        Store(70,PSVT)
    }
    If(Lequal(Arg1,1))
    {
        // Stay in Acoustic Level 1.
        Store(60,PSVT)
    }
}
Case(5) // Power Limit = 5.
{
    // Store Highest supported Acoustic Level
    // at this Power Limit (1, 2, 3, 4, or 5).
    Store(97,PSVT)
    If(Lequal(Arg1,4))
    {
        // Stay in Acoustic Level 1 or 2.
        Store(90,PSVT)
    }
    If(Lequal(Arg1,3))
    {
        // Stay in Acoustic Level 1 or 2.
        Store(80,PSVT)
    }
    If(Lequal(Arg1,2))
    {
        // Stay in Acoustic Level 1 or 2.
        Store(70,PSVT)
    }
    If(Lequal(Arg1,1))
    {
        // Stay in Acoustic Level 1.
        Store(60,PSVT)
    }
} // Case 5

```

(continues on next page)

(continued from previous page)

```

        } // Switch Arg 2
    } // \_OSI - Extended \_SCP
} // CondRefOf \_OSI
} // Method \_SCP

```

11.4.14 **_STR (String)**

This optional object, when defined under a thermal zone, returns a string name for this thermal zone. See below for more details.

11.4.15 **_TC1 (Thermal Constant 1)**

This object evaluates to the constant `_TC1` for use in the Passive cooling formula:

$$\Delta Performance[\%] = _TC1 * (T_n - T_{n-1}) + _TC2 * (T_n - T_t)$$

Arguments:

None

Return Value:

An Integer containing Thermal Constant #1

11.4.16 **_TC2 (Thermal Constant 2)**

This object evaluates to the constant `_TC2` for use in the Passive cooling formula:

$$\Delta Performance[\%] = _TC1 * (T_n - T_{n-1}) + _TC2 * (T_n - T_t)$$

Arguments:

None

Return Value:

An Integer containing Thermal Constant #2

11.4.17 **_TFP (Thermal fast Sampling Period)**

This object evaluates to a thermal sampling period (in milliseconds) used by OSPM to implement the Passive cooling equation. This value, along with `_TC1` and `_TC2`, will enable OSPM to provide the proper hysteresis required by the system to accomplish an effective passive cooling policy.

Arguments:

None

Return Value:

An Integer containing the sampling period in milliseconds

The granularity of the sampling period is 1 millisecond. For example, if the sampling period is 30.0 seconds, then `_TFP` needs to report 30,000; if the sampling period is 0.5 seconds, then it will report 500. OSPM can normalize the sampling over a longer period if necessary.

If both `_TFP` and `_TSP` are present in a Thermal Zone, `_TFP` overrides `_TSP`. Platforms which need to support legacy operating systems from before `_TFP` in ACPI 6.0, must specify a `_TSP` if a sampling period is required. OS support for `_TFP` can be discovered via `_OSC`. See *Platform-Wide _OSC Capabilities DWORD 2*.

11.4.18 _TMP (Temperature)

This control method returns the thermal zone's current operating temperature.

Arguments:

None

Return Value:

An Integer containing the current temperature of the thermal zone (in tenths of degrees Kelvin)

The return value is the current temperature of the thermal zone in tenths of degrees Kelvin. For example, 300.0K is represented by the integer 3000.

11.4.19 _TPT (Trip Point Temperature)

This optional object may be present under a device and is invoked by OSPM to indicate to the platform that the device's embedded temperature sensor has crossed a cooling temperature trip point. After invocation, OSPM immediately evaluates the device's Active and Passive cooling temperature trip point values. This enables the platform to implement hysteresis.

Arguments:(1)

Arg0 - An Integer containing the current value of the temperature sensor (in tenths Kelvin)

Return Value:

None

The `_TPT` object is deprecated in ACPI 4.0. The `_DTI` object should be used instead (see *_DTI (Device Temperature Indication)*).

11.4.20 _TRT (Thermal Relationship Table)

This object evaluates to a package of packages each of which describes the thermal relationship between devices within a thermal zone. OSPM uses the combined information about the thermal relationships of all devices in the thermal zone to make thermal policy decisions.

Arguments:

None

Return Value:

A variable-length Package containing a list of Thermal Relationship Packages as described below

Return Value Information

```
Package {
    ThermalRelationship[0] // Package
    ....
    ThermalRelationship[n] // Package
}
```

Each ThermalRelationship sub-Package contains the elements described below:

```
Package {
    SourceDevice,           // Object Reference to a Device Object
    TargetDevice,          // Object Reference to a Device Object
    Influence,             // Integer
    SamplingPeriod,        // Integer
    Reserved1,             // Integer
    Reserved2,             // Integer
    Reserved3,             // Integer
    Reserved4              // Integer
},
```

Table 11.7: Thermal Relationship Package Values 2

Element	Object Type	Description
Source Device	Reference (to a device)	The device that is influencing the device indicated by TargetDevice.
Target Device	Reference (to a device)	The device that is influenced by the device indicated by SourceDevice.
Influence	Integer	The thermal influence of SourceDevice on TargetDevice - represented as tenths of degrees Kelvin that the device indicated by SourceDevice raises the temperature of the device indicated by TargetDevice per watt of thermal load that SourceDevice generates.
Sampling Period	Integer	The minimum period of time in tenths of seconds that OSPM should wait after applying a passive control to the device indicated by SourceDevice to detect its impact on the device indicated by TargetDevice.
Reserved (1-4)	Integer	Reserved for future use.

11.4.21 _TSN (Thermal Sensor Device)

This object, when defined under a thermal zone, returns a reference to the thermal sensor device used to monitor the temperature of the thermal zone. See *Native OS Device Driver Thermal Interfaces*.

Arguments:

None

Return Value:

A single Reference to the namespace device object that monitors the temperature of the thermal zone.

11.4.22 **_TSP (Thermal Sampling Period)**

This object evaluates to a thermal sampling period (in tenths of seconds) used by OSPM to implement the Passive cooling equation. This value, along with `_TC1` and `_TC2`, will enable OSPM to provide the proper hysteresis required by the system to accomplish an effective passive cooling policy.

Arguments:

None

Return Value:

An Integer containing the sampling period in tenths of seconds

The granularity of the sampling period is 0.1 seconds. For example, if the sampling period is 30.0 seconds, then `_TSP` needs to report 300; if the sampling period is 0.5 seconds, then it will report 5. OSPM can normalize the sampling over a longer period if necessary.

If both `_TFP` and `_TSP` are present in a Thermal Zone, `_TFP` overrides `_TSP`. Platforms which need to support legacy operating systems from before `_TFP` in ACPI 6.0 must specify a `_TSP` if a sampling period is required. OS support for `_TFP` can be discovered via `_OSC` (see *Platform-Wide `_OSC` Capabilities DWORD 2*).

11.4.23 **_TST (Temperature Sensor Threshold)**

This optional object may be present under a device and is evaluated by OSPM to determine the minimum separation for a devices' programmable temperature trip points. When a device contains multiple programmable temperature trip points, it may not be necessary for OSPM to poll the device's temperature after crossing a temperature trip point when performing passive cooling control policy.

Arguments:

None

Return Value:

An Integer containing the sensor threshold (in tenths of degrees Kelvin)

To eliminate polling, the device can program intermediate trip points of interest (higher or lower than the current temperature) and signal the crossing of the intermediate trip points to OSPM. The distance between the current temperature and these intermediate trip points may be platform specific and must be set far enough away from the current temperature so as to not miss the crossing of a meaningful temperature point. The `_TST` object conveys the recommended minimum separation between the current temperature and an intermediate temperature trip point to OSPM.

11.4.24 **_TZD (Thermal Zone Devices)**

This optional object evaluates to a package of device names. Each name corresponds to a device in the ACPI namespace that is associated with the thermal zone. The temperature reported by the thermal zone is roughly correspondent to that of each of the devices.

Arguments:

None

Return Value:

A variable-length Package containing a list of References to thermal zone devices

The list of devices returned by the control method need not be a complete and absolute list of devices affected by the thermal zone. However, the package should at least contain the devices that would uniquely identify where this

thermal zone is located in the machine. For example, a thermal zone in a docking station should include a device in the docking station, a thermal zone for the CD-ROM bay, should include the CD-ROM.

11.4.25 **_TZM (Thermal Zone Member)**

This optional object may exist under any device definition and evaluates to a reference to the thermal zone of which the device is a member.

Arguments:

None

Return Value:

A Reference to the parent device

11.4.26 **_TZP (Thermal Zone Polling)**

This optional object evaluates to a recommended polling frequency (in tenths of seconds) for this thermal zone. A value of zero indicates that OSPM does not need to poll the temperature of this thermal zone in order to detect temperature changes (the hardware is capable of generating asynchronous notifications).

Arguments:

None

Return Value:

An Integer containing the recommended polling frequency in tenths of seconds

The return value contains the recommended polling frequency, in tenths of seconds. A value of zero indicates that polling is not necessary.

The `_TZP` value is specified as tenths of seconds with a 1 second granularity. For example, a `_TZP` value of 300 equals 30 seconds, while a value of 3000 equals 5 minutes. This is only a recommended value, and OSPM will consider other factors when determining the actual polling frequency to use.

The use of polling is allowed but strongly discouraged by this specification. OEMs should design systems that asynchronously notify OSPM whenever a meaningful change in the zone's temperature occurs—relieving the OS of the overhead associated with polling (see *Detecting Temperature Changes* for more details).

11.5 Native OS Device Driver Thermal Interfaces

OS implementations compatible with the ACPI 3.0 thermal model, interface with the thermal objects of a thermal zone but also comprehend the thermal zone devices' OS native device driver interfaces that perform similar functions to the thermal objects at the device level.

The recommended native OS device driver thermal interfaces that enable OSPM to perform optimal performance / thermal management include:

- Reading a value from a device's embedded thermal sensor
- Reading a value that indicates whether temperature and trip point values are reported in absolute or relative temperatures
- Setting the platform's cooling mode policy setting
- Reading the embedded thermal sensor's threshold

- Reading the device's active and passive cooling temperature trip points
- Reading the device's association to a thermal zone
- Signaling the crossing of a thermal trip point
- Reading the desired polling frequency at which to check the device's temperature if the device cannot signal OSPM or signal OSPM optimally (both before and after a temperature trip point is crossed)
- Setting / limiting a device's performance / throttling states
- Engaging / disengaging a device's active cooling controls

These interfaces are OS specific and as such the OS vendor defines the exact interface definition for each target operating system.

11.6 Thermal Zone Interface Requirements

While not all thermal zone interfaces are required to be present in each thermal zone, OSPM levies conditional requirements for the presence of specific thermal zone interfaces based on the existence of other related thermal zone interfaces. These interfaces may be implemented by thermal zone-wide objects or by OS-specific device driver exposed thermal interfaces. The requirements are outlined below:

- A thermal zone must contain at least one temperature interface; either the `_TMP` object or a member device temperature interface.
- A thermal zone must contain at least one trip point (critical, near critical, active, or passive).
- If `_ACx` is defined then an associated `_ALx` must be defined (e.g. defining `_AC0` requires `_AL0` also be defined).
- If `_PSV` is defined then either the `_PSL` or `_TZD` objects must exist. The `_PSL` and `_TZD` objects may both exist.
- If `_PSL` is defined then:
 - If a linear performance control register is defined (via either `P_BLK` or the `_PTC`, `_TSS`, `_TPC` objects) for a processor defined in `_PSL` or for a processor device in the zone as indicated by `_TZM` then the `_TC1`, `_TC2`, and objects must exist. A `_TFP` or `_TSP` object must also be defined if the device requires polling.
 - If a linear performance control register is not defined (via either `P_BLK` or the `_PTC`, `_TSS`, `_TPC` objects) for a processor defined in `_PSL` or for a processor device in the zone as indicated by `_TZM` then the processor must support processor performance states (in other words, the processor's processor object must include `_PCT`, `_PSS`, and `_PPC`).
- If `_PSV` is defined and `_PSL` is not defined then at least one device in thermal zone, as indicated by either the `_TZD` device list or devices' `_TZM` objects, must support device performance states.
- `_SCP` is optional.
- `_TZD` is optional outside of the `_PSV` requirement outlined above.
- If `_HOT` is defined then the system must support the S4 sleeping state.

11.7 Thermal Zone Examples

11.7.1 Example: The Basic Thermal Zone

The following ASL describes a basic configuration where the entire system is treated as a single thermal zone. Cooling devices for this thermal zone consist of a processor and one single-speed fan. This is an example only.

Notice that this thermal zone object (TZ0) is defined in the _SB scope. Thermal zone objects should appear in the namespace under the portion of the system that comprises the thermal zone. For example, a thermal zone that is isolated to a docking station should be defined within the scope of the docking station device. Besides providing for a well-organized namespace, this configuration allows OSPM to dynamically adjust its thermal policy as devices are added or removed from the system.

```
Scope (\_SB) {
    Device (CPU0) {
        Name (_HID, "ACPI0007")
        Name (_UID, 1) // unique number for this processor
    }
    <...>
    Scope (\_SB.PCI0.ISA0) {
        Device (EC0) {
            Name (_HID, EISAID("PNP0C09")) // ID for this EC
            // current resource description for this EC
            Name (_CRS, ResourceTemplate() {
                IO(Decode16, 0x62, 0x62, 0, 1)
                IO(Decode16, 0x66, 0x66, 0, 1)
            })
            Name (_GPE, 0) // GPE index for this EC
            // create EC's region and field for thermal support
            OperationRegion (EC0, EmbeddedControl, 0, 0xFF)
            Field (EC0, ByteAcc, Lock, Preserve) {
                MODE, 1, // thermal policy (quiet/perform)
                FAN, 1, // fan power (on/off)
                , 6, // reserved
                TMP, 16, // current temp
                AC0, 16, // active cooling temp (fan high)
                , 16, // reserved
                PSV, 16, // passive cooling temp
                HOT, 16, // critical S4 temp
                CRT, 16 // critical temp
            }
            // following is a method that OSPM will schedule after
            // it receives an SCI and queries the EC to receive value 7
            Method (_Q07) {
                Notify (\_SB.PCI0.ISA0.EC0.TZ0, 0x80)
            } // end of Notify method
            // fan cooling on/off - engaged at AC0 temp
            PowerResource (PFAN, 0, 0) {
                Method (_STA) { Return (\_SB.PCI0.ISA0.EC0.FAN) } // check power state
                Method (_ON) { Store (One, \_SB.PCI0.ISA0.EC0.FAN) } // turn on fan
                Method (_OFF) { Store (Zero, \_SB.PCI0.ISA0.EC0.FAN) } // turn off fan
            }

            // Create FAN device object
            Device (FAN) {
                // Device ID for the FAN
                Name (_HID, EISAID("PNP0C0B"))
            }
        }
    }
}
```

(continues on next page)

(continued from previous page)

```

    // list power resource for the fan
    Name(_PR0, Package() {PFAN})
}
// create a thermal zone
ThermalZone (TZ0) {
    Method(_TMP) { Return (\_SB.PCI0.ISA0.EC0.TMP) } // get current temp
    Method(_AC0) { Return (\_SB.PCI0.ISA0.EC0.AC0) } // fan high temp
    Name(_AL0, Package() {\_SB.PCI0.ISA0.EC0.FAN}) // fan is act cool dev
    Method(_PSV) { Return (\_SB.PCI0.ISA0.EC0.PSV) } // passive cooling temp
    Name(_PSL, Package () {\_SB.CPU0}) // passive cooling devices
    Method(_HOT) { Return (\_SB.PCI0.ISA0.EC0.HOT) } // get critical S4 temp
    Method(_CRT) { Return (\_SB.PCI0.ISA0.EC0.CRT) } // get critical temp
    Method(_SCP, 1) { Store (Arg1, \_SB.PCI0.ISA0.EC0.MODE) } // set cooling mode
    Name(_TC1, 4) // bogus example constant
    Name(_TC2, 3) // bogus example constant
    Name(_TSP, 150) // passive sampling = 15 sec
    Name(_TZP, 0) // polling not required
    Name (_STR, Unicode ("System thermal zone"))
} // end of TZ0
} // end of ECO
} // end of \_SB.PCI0.ISA0 scope-
} // end of \_SB scope

```

11.7.2 Example: Multiple-Speed Fans

The following ASL describes a thermal zone consisting of a processor and one dual-speed fan. As with the previous example, this thermal zone object (TZ0) is defined in the `_SB` scope and represents the entire system. This is an example only.

```

Scope (\_SB) {
    Device (CPU0) {
        Name (_HID, "ACPI0007")
        Name (_UID, 1) // unique number for this processor
    }
<...>
Scope (\_SB.PCI0.ISA0) {
    Device (EC0) {
        Name (_HID, EISAID("PNP0C09")) // ID for this EC
        // current resource description for this EC
        Name (_CRS, ResourceTemplate() {
            IO(Decode16, 0x62, 0x62, 0, 1)
            IO(Decode16, 0x66, 0x66, 0, 1)
        })
        Name (_GPE, 0) // GPE index for this EC
        // create EC's region and field for thermal support
        OperationRegion (EC0, EmbeddedControl, 0, 0xFF)
        Field (EC0, ByteAcc, Lock, Preserve) {
            MODE, 1, // thermal policy (quiet/perform)
            FAN0, 1, // fan strength high/off
            FAN1, 1, // fan strength low/off
            , 5, // reserved
            TMP, 16, // current temp
            AC0, 16, // active cooling temp (high)
            AC1, 16, // active cooling temp (low)
            PSV, 16, // passive cooling temp
        }
    }
}

```

(continues on next page)

(continued from previous page)

```

        HOT, 18, // critical S4 temp
        CRT, 16 // critical temp
    }
    // following is a method that OSPM will schedule after it
    // receives an SCI and queries the EC to receive value 7
    Method(_Q07) {
        Notify (\_SB.PCI0.ISA0.EC0.TZ0, 0x80)
    } end of Notify method
    // fan cooling mode high/off - engaged at AC0 temp
    PowerResource(FN10, 0, 0) {
        Method(_STA) { Return (\_SB.PCI0.ISA0.EC0.FAN0) } // check power state
        Method(_ON) { Store (One, \_SB.PCI0.ISA0.EC0.FAN0) } // turn on fan at_
↪high
        Method(_OFF) { Store (Zero, \_SB.PCI0.ISA0.EC0.FAN0) } // turn off fan
    }
    // fan cooling mode low/off - engaged at AC1 temp
    PowerResource(FN11, 0, 0) {
        Method(_STA) { Return (\_SB.PCI0.ISA0.EC0.FAN1) } // check power state
        Method(_ON) { Store (One, \_SB.PCI0.ISA0.EC0.FAN1) } // turn on fan at_
↪low
        Method(_OFF) { Store (Zero, \_SB.PCI0.ISA0.EC0.FAN1) } // turn off fan
    }
}

// Following is a single fan with two speeds. This is represented
// by creating two logical fan devices. When FN2 is turned on then
// the fan is at a low speed. When FN1 and FN2 are both on then
// the fan is at high speed.
//
// Create FAN device object FN1
Device (FN1) {
    // Device ID for the FAN
    Name(_HID, EISAID("PNP0COB"))
    Name(_UID, 0)
    Name(_PR0, Package() {FN10, FN11})
}
// Create FAN device object FN2
Device (FN2) {
    // Device ID for the FAN
    Name(_HID, EISAID("PNP0COB"))
    Name(_UID, 1)
    Name(_PR0, Package() {FN10})
}
// create a thermal zone
ThermalZone (TZ0) {
    Method(_TMP) { Return (\_SB.PCI0.ISA0.EC0.TMP) } // get current temp
    Method(_AC0) { Return (\_SB.PCI0.ISA0.EC0.AC0) } // fan high temp
    Method(_AC1) { Return (\_SB.PCI0.ISA0.EC0.AC1) } // fan low temp
    Name(_AL0, Package() {\_SB.PCI0.ISA0.EC0.FN1}) // active cooling (high)
    Name(_AL1, Package() {\_SB.PCI0.ISA0.EC0.FN2}) // active cooling (low)
    Method(_PSV) { Return (\_SB.PCI0.ISA0.EC0.PSV) } // passive cooling temp
    Name(_PSL, Package() {\_SB.CPU0}) // passive cooling devices
    Method(_HOT) { Return (\_SB.PCI0.ISA0.EC0.HOT) } // get critical S4 temp
    Method(_CRT) { Return (\_SB.PCI0.ISA0.EC0.CRT) } // get crit. temp
    Method(_SCP, 1) { Store (Arg1, \_SB.PCI0.ISA0.EC0.MODE) } // cooling mode
    Name(_TC1, 4) // bogus example constant
    Name(_TC2, 3) // bogus example constant
    Name(_TSP, 150) // passive sampling = 15 sec
    Name(_TZP, 0) // polling not required
}

```

(continues on next page)

(continued from previous page)

```

    } // end of TZ0
  } // end of ECO
} // end of \\_SB.PCI0.ISA0 scope
} // end of \\_SB scope

```

11.7.3 Example: Thermal Zone with Multiple Devices

```

Scope(\_SB) {
  Device(CPU0) {
    Name(_HID, "ACPI0007")
    Name(_UID, 0)
    //
    // Load additional objects if 3.0 Thermal model support is available
    //
    Method(_INI, 0) {
      If (\_OSI("3.0 Thermal Model")) {
        LoadTable("OEM1", "PmRef", "Cpu0", "\\_SB.CPU0") // 3.0 Thermal Model
      }
    }
    // For brevity, most processor objects have been excluded
    // from this example (such as \_PSS, \_CST, \_PCT, \_PPC, etc.)
    // Processor Throttle Control object
    Name(_PTC, ResourceTemplate() {
      Register(SystemIO, 32, 0, 0x120) // Processor Control
      Register(SystemIO, 32, 0, 0x120) // Processor Status
    })
    // Throttling Supported States
    // The values shown are for exemplary purposes only
    Name(_TSS, Package() {
      // Read: freq percentage, power, latency, control, status
      Package() {0x64, 1000, 0x0, 0x7, 0x0}, // Throttle off (100%)
      Package() {0x58, 800, 0x0, 0xF, 0x0}, // 87.5%
      Package() {0x4B, 600, 0x0, 0xE, 0x0}, // 75%
      Package() {0x3F, 400, 0x0, 0xD, 0x0} // 62.5%
    })
    // Throttling Present Capabilities
    // The values shown are for exemplary purposes only
    Method(_TPC) {
      If (\_SB.AC) {
        Return(0) // All throttle states available
      } Else {
        Return(2) // Throttle states >= 2 are available
      }
    }
  } // end of CPU0 scope
  Device(CPU1) {
    Name(_HID, "ACPI0007")
    Name(_UID, 1)
    //
    // Load additional objects if 3.0 Thermal model support is available
    //
    Method(_INI, 0) {
      If (\_OSI("3.0 Thermal Model")) {
        LoadTable("OEM1", "PmRef", "Cpu1", "\\_SB.CPU1") // 3.0 Thermal Model
      }
    }
  }
}

```

(continues on next page)

(continued from previous page)

```

}
// For brevity, most processor objects have been excluded
// from this example (such as \_PSS, \_CST, \_PCT, \_PPC, \_PTC, etc.)
// Processor Throttle Control object
Name(_PTC, ResourceTemplate() {
    Register(SystemIO, 32, 0, 0x120) // Processor Control
    Register(SystemIO, 32, 0, 0x120) // Processor Status
})
// Throttling Supported States
// The values shown are for exemplary purposes only
Name(_TSS, Package() {
    // Read: freq percentage, power, latency, control, status
    Package() {0x64, 1000, 0x0, 0x7, 0x0}, // Throttle off (100%)
    Package() {0x58, 800, 0x0, 0xF, 0x0}, // 87.5%
    Package() {0x4B, 600, 0x0, 0xE, 0x0}, // 75%
    Package() {0x3F, 400, 0x0, 0xD, 0x0} // 62.5%
})
// Throttling Present Capabilities
// The values shown are for exemplary purposes only
Method(_TPC) {
    If(\_SB.AC)
        {Return(0) // All throttle states available
    } Else {
        Return(2) // Throttle states >= 2 are available
    }
}
} // end of CPU1 scope
Scope(\_SB.PCI0.ISA0) {
    Device(EC0) {
        Name(_HID, EISAID("PNP0C09")) // ID for this EC
        //
        // Load additional objects if 3.0 Thermal model support is available
        //
        Method(_INI, 0) {
            If (\_OSI("3.0 Thermal Model")) {
                LoadTable("OEM1", "PmRef", "Tz3", "\\_SB.PCI0.ISA0.EC0") // 3.0 Tz
            }
        }
        // Current resource description for this EC
        Name(_CRS,
            ResourceTemplate() {
                IO(Decode16, 0x62, 0x62, 0, 1)
                IO(Decode16, 0x66, 0x66, 0, 1)
            })
        Name(_GPE, 0) // GPE index for this EC
        // Create EC's region and field for thermal support
        OperationRegion(EC0, EmbeddedControl, 0, 0xFF)
        Field(EC0, ByteAcc, Lock, Preserve) {
            MODE, 1, // thermal policy (quiet/perform)
            FAN0, 1, // fan strength high/off
            , 6, // reserved
            TMP, 16, // current temp
            ACO, 16, // active cooling temp
            PSV, 16, // passive cooling temp
            HOT, 16, // critical S4 temp
            CRT, 16 // critical temp
        }
    }
}

```

(continues on next page)

(continued from previous page)

```

    // Following is a method that OSPM will schedule after it
    // fan cooling mode high/off - engaged at AC0 temp
    PowerResource(FN10, 0, 0) {
        Method(_STA) { Return (\_SB.PCI0.ISA0.EC0.FAN0) } // check power state
        Method(_ON) { Store (One, \_SB.PCI0.ISA0.EC0.FAN0) } // turn on fan at high
        Method(_OFF) { Store (Zero, \_SB.PCI0.ISA0.EC0.FAN0) } // turn off fan
    }
    // Following is a single fan with one speed.
    // Create FAN device object FN1
    Device (FN1) {
        // Device ID for the FAN
        Name(_HID, EISAID("PNPOCOB"))
        Name(_UID, 0)
        Name(_PR0, Package() {FN10})
    }
    // Receives an SCI and queries the EC to receive value 7
    Method(_Q07) {
        Notify (\_SB.PCI0.ISA0.EC0.TZ0, 0x80)
    } // end of Notify method
    // Create standard specific thermal zone
    ThermalZone (TZ0) {
        Method(_TMP) { Return (\_SB.PCI0.ISA0.EC0.TMP) } // get current temp
        Name(_PSL, Package() { \_SB.CPU0, \_SB.CPU1 }) // passive cooling devices
        Name(_AL0, Package() { \_SB.PCI0.ISA0.EC0.FN1 }) // active cooling
        Method(_AC0) { Return (\_SB.PCI0.ISA0.EC0.AC0) } // fan temp (high)
        Method(_AC1) { Return (\_SB.PCI0.ISA0.EC0.AC1) } // fan temp (low)
        Method(_PSV) { Return (\_SB.PCI0.ISA0.EC0.PSV) } // passive cooling temp
        Method(_HOT) { Return (\_SB.PCI0.ISA0.EC0.HOT) } // get critical S4 temp
        Method(_CRT) { Return (\_SB.PCI0.ISA0.EC0.CRT) } // get crit. temp
        Name(_TC1, 4) // bogus example constant
        Name(_TC2, 3) // bogus example constant
        Method(_SCP, 1) { Store (Arg0, \_SB.PCI0.ISA0.EC0.MODE) } // set cooling mode
        Name(_TSP, 150) // passive sampling = 15 sec
    } // end of TZ0
} // end of ECO
} // end of \_SB.PCI0.ISA0 scope
} // end of \_SB scope
//
// ACPI 3.0 Thermal Model SSDT
//
DefinitionBlock (
    "TZASSDT.aml",
    "OEM1",
    0x01,
    "PmRef",
    "Tz3",
    0x3000
)
{
    External(\_SB.PCI0.ISA0.EC0, DeviceObj)
    External(\_SB.CPU0, DeviceObj)
    External(\_SB.CPU1, DeviceObj)
    Scope(\_SB.PCI0.ISA0.EC0)
    {
        // Create an ACPI 3.0 specific thermal zone
        ThermalZone (TZ0) {

```

(continues on next page)

(continued from previous page)

```

// This TRT is for exemplary purposes only
Name(_TRT, Package() {
    // Thermal relationship package data. A package is generated for
    // each permutation of device sets. 2 devices = 4 entries.
    // Read: source, target, thermal influence, sampling period, 4 reserved
    Package () {\_SB.CPU0, \_SB.CPU0, 20, 1, 0, 0, 0, 0},
    Package () {\_SB.CPU0, \_SB.CPU1, 10, 15, 0, 0, 0, 0},
    Package () {\_SB.CPU1, \_SB.CPU0, 10, 15, 0, 0, 0, 0},
    Package () {\_SB.CPU1, \_SB.CPU1, 20, 1, 0, 0, 0, 0}
}) // end of TRT
} // end of TZ0
} // end of ECO Scope
} // end of SSDT

//
// CPU0 3.0 Thermal Model SSDT
//
DefinitionBlock (
    "CPU0SSDT.aml",
    "OEM1",
    0x01,
    "PmRef",
    "CPU0",
    0x3000
)
{
    External(\_SB.CPU0, DeviceObj)
    External(\_SB.PCI0.ISA0.TZ0, ThermalZoneObj)
    Scope(\_SB.CPU0)
    {
        //
        // Add the objects required for 3.0 extended thermal support
        //
        // Create a region and fields for thermal support; the platform
        // fills in the values and traps on writes to enable hysteresis.
        // The Operation Region location is invalid
        OperationRegion(CP00, SystemMemory, 0x00000000, 0xA)
        Field(CP00, ByteAcc, Lock, Preserve) {
            SCP, 1, // thermal policy (passive/active)
            RTV, 1, // absolute or relative temperature
            , 6, // reserved
            AC0, 16, // active cooling temp
            PSV, 16, // passive cooling temp
            CRT, 16, // critical temp
            TPT, 16, // Temp trip point crossed
            TST, 8 // Temp sensor threshold
        }
        Method(_TZM, 0) { Return(\_SB.PCI0.ISA0.TZ0) } // thermal zone member
        // Some thermal zone methods are now located under the
        // thermal device participating in the 3.0 thermal model.
        // These methods provide device specific thermal information
        Method(_SCP, 1) { Store (Arg0, \_SB.CPU0.SCP) } // set cooling mode
        Method(_RTV) { Return (\_SB.CPU0.RTV) } // absolute or relative temp
        Method(_AC0) { Return (\_SB.CPU0.AC0) } // active cooling (fan) temp
        Method(_PSV) { Return (\_SB.CPU0.PSV) } // passive cooling temp
        Method(_CRT) { Return (\_SB.CPU0.CRT) } // critical temp
        Name(_IC1, 4) // thermal constant 1 (INVALID)
    }
}

```

(continues on next page)

(continued from previous page)

```

Name(_TC2, 3) // thermal constant 2 (INVALID)
Method(_TPT, 1) { Store (Arg0, \_SB.CPU0.TPT)} // trip point temp
Method(_TST) { Return (\_SB.CPU0.TST) } // temp sensor threshold
} // end of CPU0 scope
} // end of SSDT
//
// CPU1 3.0 Thermal Model SSDT
//
DefinitionBlock (
    "CPU1SSDT.aml",
    "OEM1",
    0x01,
    "PmRef",
    "CPU1",
    0x3000
)
{
    External(\_SB.CPU1, DeviceObj)
    External(\_SB.PCI0.ISA0.TZ0, ThermalZoneObj)
    Scope(\_SB.CPU1)
    {
        //
        // Add the objects required for 3.0 extended thermal support
        //
        // Create a region and fields for thermal support; the platform
        // fills in the values and traps on writes to enable hysteresis.
        // The Operation Region location is invalid
        OperationRegion(CP01, SystemIO, 0x00000008, 0xA)
        Field(CP01, ByteAcc, Lock, Preserve) {
            SCP, 1, // thermal policy (passive/active)
            RTV, 1, // absolute or relative temperature
            , 6, // reserved
            AC0, 16, // active cooling temp
            PSV, 16, // passive cooling temp
            CRT, 16, // critical temp
            TPT, 16, // Temp trip point crossed
            TST, 8 // Temp sensor threshold
        }
        Method(_TZM, 0) { Return(\_SB.PCI0.ISA0.TZ0) } // thermal zone member
        // Some thermal zone methods are now located under the
        // thermal device participating in the 3.0 thermal model.
        // These methods provide device specific thermal information
        Method(_SCP, 1) { Store (Arg0, \_SB.CPU1.SCP) } // set cooling mode
        Method(_RTV) { Return (\_SB.CPU1.RTV) } // absolute or relative temp
        Method(_AC0) { Return (\_SB.CPU1.AC0) } // active cooling (fan) temp
        Method(_PSV) { Return (\_SB.CPU1.PSV) } // passive cooling temp
        Method(_CRT) { Return (\_SB.CPU1.CRT) } // critical temp
        Name(_TC1, 4) // thermal constant 1 (INVALID)
        Name(_TC2, 3) // thermal constant 2 (INVALID)
        Method(_TPT, 1) { Store (Arg0, \_SB.CPU1.TPT)} // trip point temp
        Method(_TST) { Return (\_SB.CPU1.TST) } // temp sensor threshold
    } // end of CPU1 scope
} // end of SSDT

```

ACPI EMBEDDED CONTROLLER INTERFACE SPECIFICATION

ACPI defines a standard hardware and software communications interface between an OS driver and an embedded controller. This allows any OS to provide a standard driver that can directly communicate with an embedded controller in the system, thus allowing other drivers within the system to communicate with and use the resources of system embedded controllers. This in turn enables the OEM to provide platform features that the OS OS/PM and applications can take advantage of.

ACPI also defines a standard hardware and software communications interface between an OS driver and an Embedded Controller-based SMB-HC (EC-SMB-HC).

The ACPI standard supports multiple embedded controllers in a system, each with its own resources. Each embedded controller has a flat byte-addressable I/O space, currently defined as 256 bytes. Features implemented in the embedded controller have an event “query” mechanism that allows feature hardware implemented by the embedded controller to gain the attention of an OS driver or ASL/AML code handler. The interface has been specified to work on the most popular embedded controllers on the market today, only requiring changes in the way the embedded controller is “wired” to the host interface.

Two interfaces are specified:

- A private interface, exclusively owned by the embedded controller driver.
- A shared interface, used by the embedded controller driver and some other driver.

This interface is separate from the traditional PC keyboard controller. Some OEMs might choose to implement the ACPI Embedded Controller Interface (ECI) within the same embedded controller as the keyboard controller function, but the ECI requires its own unique host resources (interrupt event and access registers).

This interface does support sharing the ECI with an inter-environment interface (such as SMI) and relies on the ACPI-defined “Global Lock” protocol. Note, however, that HW-reduced ACPI platforms, which do not support the Global Lock, cannot share the EC interface. For information about the Global Lock interface, see [Section 6.5.7](#).

Both the shared and private EC interfaces are described in the following sections.

The ECI has been designed such that a platform can use it in either the legacy or ACPI modes with minimal changes between the two operating environments. This is to encourage standardization for this interface to enable faster development of platforms as well as opening up features within these controllers to higher levels of software.

12.1 Embedded Controller Interface Description

Embedded controllers are the general class of microcontrollers used to support OEM-specific implementations. The ACPI specification supports embedded controllers in any platform design, as long as the microcontroller conforms to one of the models described in this section. The embedded controller is a unique feature in that it can perform complex low-level functions through a simple interface to the host microprocessor(s).

Although there is a large variety of microcontrollers in the market today, the most commonly used embedded controllers include a host interface that connects the embedded controller to the host data bus, allowing bi-directional communications. A bi-directional interrupt scheme reduces the host processor latency in communicating with the embedded controller.

Currently, the most common host interface architecture incorporated into microcontrollers is modeled after the standard IA-PC architecture keyboard controller. This keyboard controller is accessed at 0x60 and 0x64 in system I/O space. Port 0x60 is termed the data register, and allows bi-directional data transfers to and from the host and embedded controller. Port 0x64 is termed the command/status register; it returns port status information upon a read, and generates a command sequence to the embedded controller upon a write. This same class of controllers also includes a second decode range that shares the same properties as the keyboard interface by having a command/status register and a data register. The following diagram graphically depicts this interface.

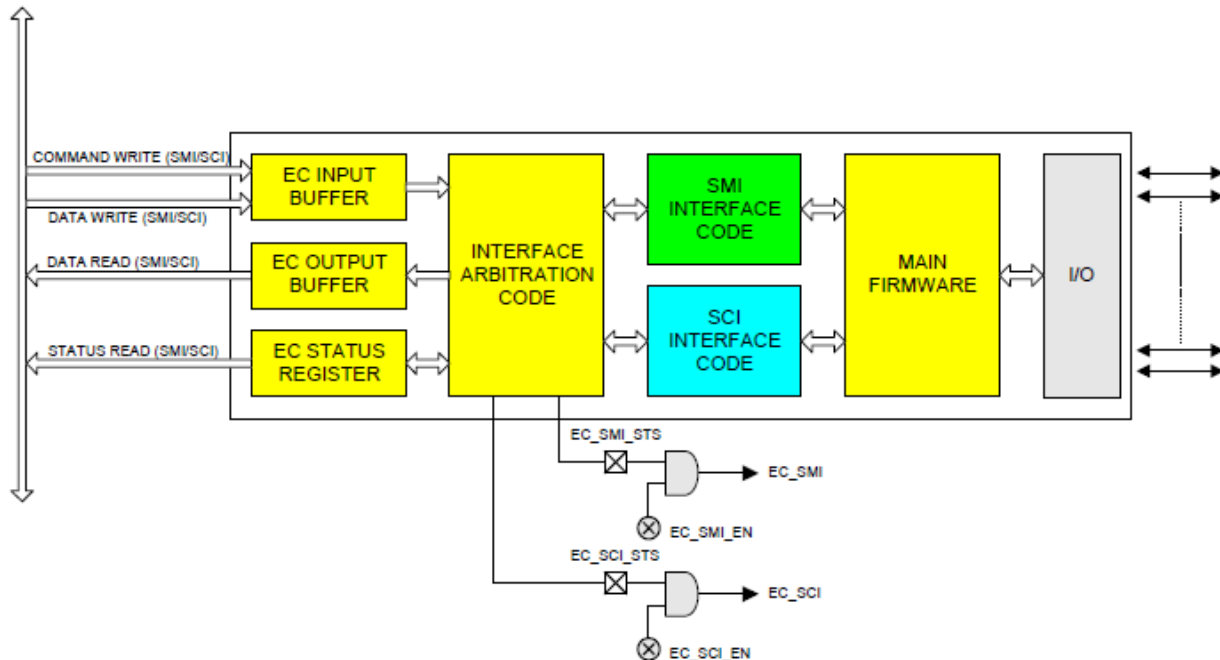

Fig. 12.1: Shared Interface

The diagram above depicts the general register model supported by the ACPI Embedded Controller Interface.

The first method uses an embedded controller interface shared between OSPM and the system management code, which requires the Global Lock semaphore overhead to arbitrate ownership. The second method is a dedicated embedded controller decode range for sole use by OSPM driver. The following diagram illustrates the embedded controller architecture that includes a dedicated ACPI interface.

The private interface allows OSPM to communicate with the embedded controller without the additional software overhead associated with using the Global Lock. Several common system configurations can provide the additional embedded controller interfaces:

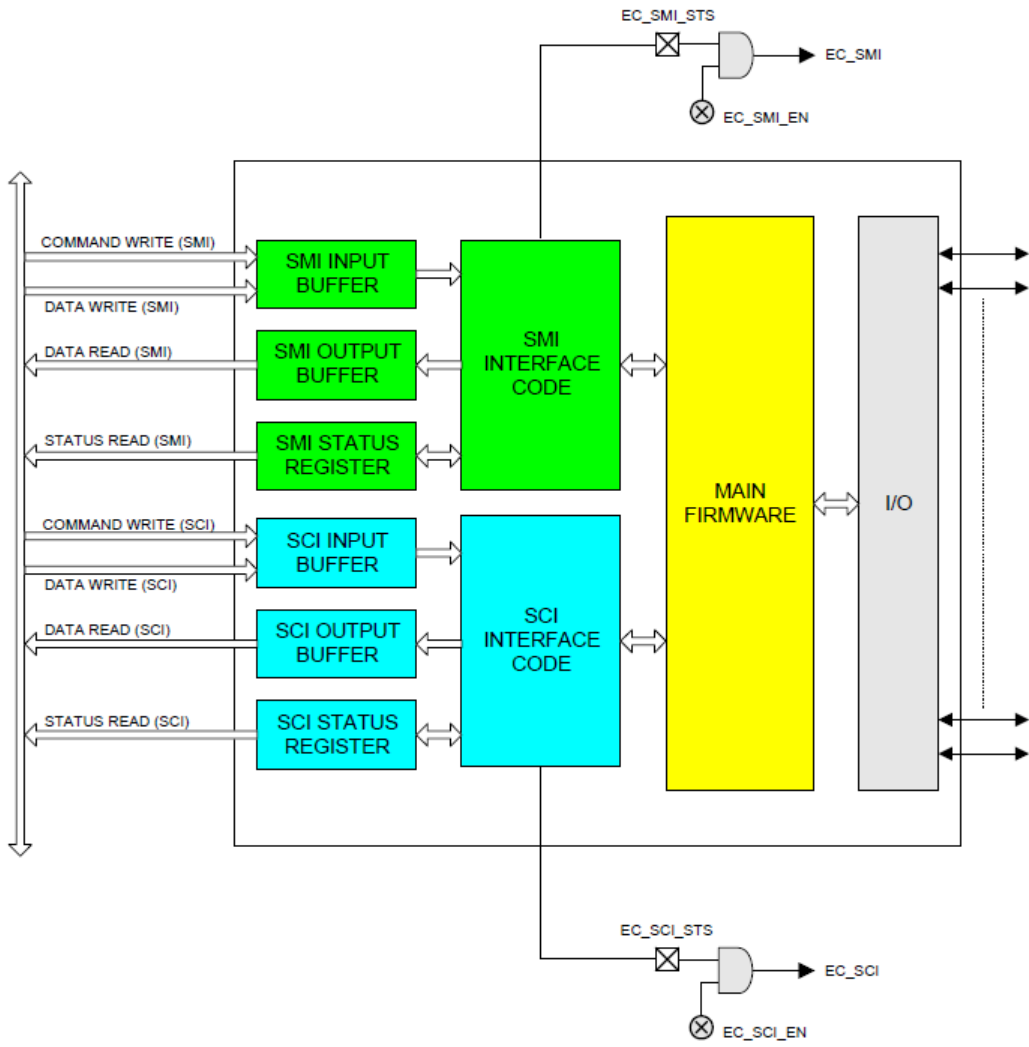

Fig. 12.2: Private Interface

- Non-shared embedded controller. This will be the most common case where there is no need for the system management handler to communicate with the embedded controller when the system transitions to ACPI mode. OSPM processes all normal types of system management events, and the system management handler does not need to take any actions.
- Integrated keyboard controller and embedded controller. This provides three host interfaces as described earlier by including the standard keyboard controller in an existing component (chip set, I/O controller) and adding a discrete, standard embedded controller with two interfaces for system management activities.
- Standard keyboard controller and embedded controller. This provides three host interfaces by providing a keyboard controller as a distinct component, and two host interfaces are provided in the embedded controller for system management activities.
- Two embedded controllers. This provides up to four host interfaces by using two embedded controllers; one controller for system management activities providing up to two host interfaces, and one controller for keyboard controller functions providing up to two host interfaces.
- Embedded controller and no keyboard controller. Future platforms might provide keyboard functionality through an entirely different mechanism, which would allow for two host interfaces in an embedded controller for system management activities.

To handle the general embedded controller interface (as opposed to a dedicated interface) model, a method is available to make the embedded controller a shareable resource between multiple tasks running under the operating system's control and the system management interrupt handler. This method, as described in this section, requires several changes:

- Additional external hardware
- Embedded controller firmware changes
- System management interrupt handler firmware changes
- Operating software changes

Access to the shared embedded controller interface requires additional software to arbitrate between the operating system's use of the interface and the system management handler's use of the interface. This is done using the Global Lock as described in [Section 6.5.7](#), but is not supported on HW-reduced ACPI platforms.

This interface sharing protocol also requires embedded controller firmware changes, in order to ensure that collisions do not occur at the interface. A collision could occur if a byte is placed in the system output buffer and an interrupt is then generated. There is a small window of time when the incorrect recipient could receive the data. This problem is resolved by ensuring that the firmware in the embedded controller does not place any data in the output buffer until it is requested by OSPM or the system management handler.

More detailed algorithms and descriptions are provided in the following sections.

12.2 Embedded Controller Register Descriptions

The embedded controller contains three registers at two address locations: EC_SC and EC_DATA. The EC_SC, or Embedded Controller Status/Command register, acts as two registers: a status register for reads to this port and a command register for writes to this port. The EC_DATA (Embedded Controller Data register) acts as a port for transferring data between the host CPU and the embedded controller.

12.2.1 Embedded Controller Status, EC_SC (R)

This is a read-only register that indicates the current status of the embedded controller interface.

Table 12.1: Read Only Register Table

Bit7	Bit6	Bit5	Bit4	Bit3	Bit2	Bit1	Bit0
IGN	SMI_EVT	SCI_EVT	BURST	CMD	IGN	IBF	OBF

Where:

IGN	Ignored
SMI_EVT:	1 - Indicates SMI event is pending (requesting SMI query). 0 - No SMI events are pending.
SCI_EVT:	1 - Indicates SCI event is pending (requesting SCI query). 0 - No SCI events are pending.
BURST:	1 - Controller is in burst mode for polled command processing. 0 - Controller is in normal mode for interrupt-driven command processing.
CMD:	1 - Byte in data register is a command byte (only used by controller). 0 - Byte in data register is a data byte (only used by controller).
IBF:	1 - Input buffer is full (data ready for embedded controller). 0 - Input buffer is empty.
OBF:	1 - Output buffer is full (data ready for host). 0 - Output buffer is empty.

The Output Buffer Full (OBF) flag is set when the embedded controller has written a byte of data into the command or data port but the host has not yet read it. After the host reads the status byte and sees the OBF flag set, the host reads the data port to get the byte of data that the embedded controller has written. After the host reads the data byte, the OBF flag is cleared automatically by hardware. This signals the embedded controller that the data has been read by the host and the embedded controller is free to write more data to the host.

The Input Buffer Full (IBF) flag is set when the host has written a byte of data to the command or data port, but the embedded controller has not yet read it. After the embedded controller reads the status byte and sees the IBF flag set, the embedded controller reads the data port to get the byte of data that the host has written. After the embedded controller reads the data byte, the IBF flag is automatically cleared by hardware. This is the signal to the host that the data has been read by the embedded controller and that the host is free to write more data to the embedded controller.

The SCI event (SCI_EVT) flag is set when the embedded controller has detected an internal event that requires the operating system's attention. The embedded controller sets this bit in the status register, and generates an SCI to OSPM. OSPM needs this bit to differentiate command-complete SCIs from notification SCIs. OSPM uses the query command to request the cause of the SCI_EVT and take action. For more information, see *Embedded Controller Command Set*.

The SMI event (SMI_EVT) flag is set when the embedded controller has detected an internal event that requires the system management interrupt handler's attention. The embedded controller sets this bit in the status register before generating an SMI.

The Burst (BURST) flag indicates that the embedded controller has received the burst enable command from the host, has halted normal processing, and is waiting for a series of commands to be sent from the host. This allows OSPM or system management handler to quickly read and write several bytes of data at a time without the overhead of SCIs between the commands.

12.2.2 Embedded Controller Command, EC_SC (W)

This is a write-only register that allows commands to be issued to the embedded controller. Writes to this port are latched in the input data register and the input buffer full flag is set in the status register. Writes to this location also cause the command bit to be set in the status register. This allows the embedded controller to differentiate the start of a command sequence from a data byte write operation.

12.2.3 Embedded Controller Data, EC_DATA (R/W)

This is a read/write register that allows additional command bytes to be issued to the embedded controller, and allows OSPM to read data returned by the embedded controller. Writes to this port by the host are latched in the input data register, and the input buffer full flag is set in the status register. Reads from this register return data from the output data register and clear the output buffer full flag in the status register.

12.3 Embedded Controller Command Set

The embedded controller command set allows OSPM to communicate with the embedded controllers. ACPI defines the commands and their byte encodings for use with the embedded controller that are shown in the following table.

Table 12.3: Embedded Controller Commands

Embedded Controller Command	Command Byte Encoding
Read Embedded Controller (RD_EC)	0x80
Write Embedded Controller (WR_EC)	0x81
Burst Enable Embedded Controller (BE_EC)	0x82
Burst Disable Embedded Controller (BD_EC)	0x83
Query Embedded Controller (QR_EC)	0x84

12.3.1 Read Embedded Controller, RD_EC (0x80)

This command byte allows OSPM to read a byte in the address space of the embedded controller. This command byte is reserved for exclusive use by OSPM, and it indicates to the embedded controller to generate SCIs in response to related transactions (that is, IBF=0 or OBF=1 in the EC Status Register), rather than SMIs. This command consists of a command byte written to the Embedded Controller Command register (EC_SC), followed by an address byte written to the Embedded Controller Data register (EC_DATA). The embedded controller then returns the byte at the addressed location. The data is read at the data port after the OBF flag is set.

12.3.2 Write Embedded Controller, WR_EC (0x81)

This command byte allows OSPM to write a byte in the address space of the embedded controller. This command byte is reserved for exclusive use by OSPM, and it indicates to the embedded controller to generate SCIs in response to related transactions (that is, IBF=0 or OBF=1 in the EC Status Register), rather than SMIs. This command allows OSPM to write a byte in the address space of the embedded controller. It consists of a command byte written to the Embedded Controller Command register (EC_SC), followed by an address byte written to the Embedded Controller Data register (EC_DATA), followed by a data byte written to the Embedded Controller Data Register (EC_DATA); this is the data byte written at the addressed location.

12.3.3 Burst Enable Embedded Controller, BE_EC (0x82)

This command byte allows OSPM to request dedicated attention from the embedded controller and (except for critical events) prevents the embedded controller from doing tasks other than receiving command and data from the host processor (either the system management interrupt handler or OSPM). This command is an optimization that allows the host processor to issue several commands back to back, in order to reduce latency at the embedded controller interface. When the controller is in the burst mode, it should transition to the burst disable state if the host does not issue a command within the following guidelines:

- First Access - 400 microseconds
- Subsequent Accesses - 50 microseconds each
- Total Burst Time - 1 millisecond

In addition, the embedded controller can disengage the burst mode at any time to process a critical event. If the embedded controller disables burst mode for any reason other than the burst disable command, it should generate an SCI to OSPM to indicate the change.

While in burst mode, the embedded controller follows these guidelines for OSPM driver:

SCIs are generated as normal, including IBF=0 and OBF=1.

Accesses should be responded to within 50 microseconds.

Burst mode is entered in the following manner:

OSPM driver writes the Burst Enable Embedded Controller, BE_EC (0x82) command byte and then the Embedded Controller will prepare to enter the Burst mode. This includes processing any routine activities such that it should be able to remain dedicated to OSPM interface for ~ 1 microsecond.

The Embedded Controller sets the Burst bit of the Embedded Controller Status Register, puts the Burst Acknowledge byte (0x90) into the SCI output buffer, sets the OBF bit, and generates an SCI to signal OSPM that it is in Burst mode.

Burst mode is exited the following manner:

OSPM driver writes the Burst Disable Embedded Controller, BD_EC (0x83) command byte and then the Embedded Controller will exit Burst mode by clearing the Burst bit in the Embedded Controller Status register and generating an SCI signal (due to IBF=0).

The Embedded Controller clears the Burst bit of the Embedded Controller Status Register.

12.3.4 Burst Disable Embedded Controller, BD_EC (0x83)

This command byte releases the embedded controller from a previous burst enable command and allows it to resume normal processing. This command is sent by OSPM or system management interrupt handler after it has completed its entire queued command sequence to the embedded controller.

12.3.5 Query Embedded Controller, QR_EC (0x84)

OSPM driver sends this command when the SCI_EVT flag in the EC_SC register is set. When the embedded controller has detected a system event that must be communicated to OSPM, it first sets the SCI_EVT flag in the EC_SC register, generates an SCI, and then waits for OSPM to send the query (QR_EC) command. OSPM detects the embedded controller SCI, sees the SCI_EVT flag set, and sends the query command to the embedded controller. Upon receipt of the QR_EC command byte, the embedded controller places a notification byte with a value between 0-255, indicating the cause of the notification. The notification byte indicates which interrupt handler operation should be executed by OSPM to process the embedded controller SCI. The query value of zero is reserved for a spurious query result and indicates “no outstanding event.”

12.4 SMBus Host Controller Notification Header (Optional), OS_SMB_EVT

This query command notification header is the special return code that indicates events with an SMBus controller implemented within an embedded controller. These events include:

- Command completion
- Command error
- Alarm reception

The actual notification value is declared in the EC-SMB-HC device object in the ACPI Namespace.

12.5 Embedded Controller Firmware

The embedded controller firmware must obey the following rules in order to be ACPI-compatible:

- **SMI Processing.** Although it is not explicitly stated in the command specification section, a shared embedded controller interface has a separate command set for communicating with each environment it plans to support. In other words, the embedded controller knows which environment is generating the command request, as well as which environment is to be notified upon event detection, and can then generate the correct interrupts and notification values. This implies that a system management handler uses commands that parallel the functionality of all the commands for ACPI including query, read, write, and any other implemented specific commands.
- **SCI/SMI Task Queuing.** If the system design is sharing the interface between both a system management interrupt handler and OSPM, the embedded controller should always be prepared to queue a notification if it receives a command. The embedded controller only sets the appropriate event flag in the status (EC_SC) register if the controller has detected an event that should be communicated to the OS or system management handler. The embedded controller must be able to field commands from either environment without loss of the notification event. At some later time, the OS or system management handler issues a query command to the embedded controller to request the cause of the notification event.
- **Notification Management.** The use of the embedded controller means using the query (QR_EC) command to notify OSPM of system events requiring action. If the embedded controller is shared with the operating system, the SMI handler uses the SMI_EVT flag and an SMI query command (not defined in this document) to receive the event notifications. The embedded controller doesn't place event notifications into the output buffer of a shared interface unless it receives a query command from OSPM or the system management interrupt handler.

12.6 Interrupt Model

The EC Interrupt Model uses pulsed interrupts to speed the clearing process. The Interrupt is firmware generated using an EC general-purpose output and has the waveform shown in *Interrupt Model*. The embedded controller SCI is always wired directly to a GPE input or a GPIO pin, and OSPM driver treats this as an edge event (the EC SCI cannot be shared).

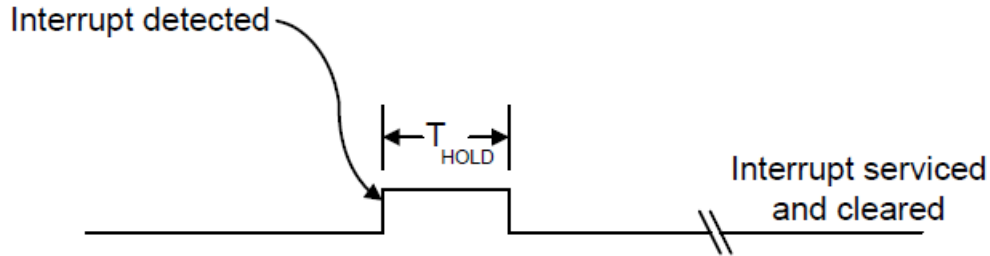

Fig. 12.3: Interrupt Model

12.6.1 Event Interrupt Model

The embedded controller must generate SCIs for the events listed in the following table.

Table 12.4: Events for Which Embedded Controller Must Generate SCIs

Event	Description
IBF=0	Signals that the embedded controller has read the last command or data from the input buffer and the host is free to send more data.
OBF=1	Signals that the embedded controller has written a byte of data into the output buffer and the host is free to read the returned data.
SCI_EVT=1	Signals that the embedded controller has detected an event that requires OS attention. OSPM should issue a query (QR_EC) command to find the cause of the event.

12.6.2 Command Interrupt Model

The embedded controller must generate SCIs for commands as follows:

Table 12.5: Read Command (3 Bytes)

Byte #1	(Command byte Header)	Interrupt on IBF=0
Byte #2	(Address byte to read)	No Interrupt
Byte #3	(Data read to host)	Interrupt on OBF=1

Table 12.6: Write Command (3 Bytes)

Byte #1	(Command byte Header)	Interrupt on IBF=0
Byte #2	(Address byte to write)	Interrupt on IBF=0
Byte #3	(Data to read)	Interrupt on IBF=0

Table 12.7: Query Command (2 Bytes)

Byte #1	(Command byte Header)	No Interrupt
Byte #2	(Query value to host)	Interrupt on OBF=1

Table 12.8: **Burst Enable Command (2 Bytes)**

Byte #1	(Command byte Header)	No Interrupt
Byte #2	(Burst acknowledge byte)	Interrupt on OBF=1

Table 12.9: **Burst Disable Command (1 Byte)**

Byte #1	(Command byte Header)	Interrupt on IBF=0
---------	-----------------------	--------------------

12.7 Embedded Controller Interfacing Algorithms

To initiate communications with the embedded controller, OSPM or system management handler acquires ownership of the interface. This ownership is acquired through the use of the *Global Lock*, or is owned by default by OSPM as a non-shared resource (and the Global Lock is not required for accessibility).

After ownership is acquired, the protocol always consists of the passing of a command byte. The command byte will indicate the type of action to be taken. Following the command byte, zero or more data bytes can be exchanged in either direction. The data bytes are defined according to the command byte that is transferred.

The embedded controller also has two status bits that indicate whether the registers have been read. This is used to ensure that the host or embedded controller has received data from the embedded controller or host. When the host writes data to the command or data register of the embedded controller, the input buffer flag (IBF) in the status register is set within 1 microsecond. When the embedded controller reads this data from the input buffer, the input buffer flag is reset. When the embedded controller writes data into the output buffer, the output buffer flag (OBF) in the status register is set. When the host processor reads this data from the output buffer, the output buffer flag is reset.

12.8 Embedded Controller Description Information

Certain aspects of the embedded controller's operation have OEM-definable values associated with them. The following is a list of values that are defined in the software layers of the ACPI specification:

- Status flag indicating whether the interface requires the use of the Global Lock.
- Bit position of embedded controller interrupt in general-purpose status register.
- Decode address for command/status register.
- Decode address for data register.
- Base address and query value of any EC-SMBus controller.

For implementation details of the above information, see *Defining an Embedded Controller Device in ACPI Namespace* and *Defining an EC SMBus Host Controller in ACPI Namespace*.

An embedded controller will require the inclusion of the GLK method in its ACPI namespace if potentially contentious accesses to device resources are performed by non-OS code. See *_GLK (Global Lock)* for details about the *_GLK* method.

12.9 SMBus Host Controller Interface via Embedded Controller

This section specifies a standard interface that an ACPI-compatible OS can use to communicate with embedded controller-based SMBus host controllers (EC-SMB-HC). This interface allows the host processor (under control of OSPM) to manage devices on the SMBus. Typical devices residing on the SMBus include Smart Batteries, Smart Battery Chargers, contrast/backlight control, and temperature sensors.

The EC-SMB-HC interface consists of a block of registers that reside in embedded controller space. These registers are used by software to initiate SMBus transactions and receive SMBus notifications. By using a well-defined register set, OS software can be written to operate with any vendor's embedded controller hardware.

Certain SMBus segments have special requirements that the host controller filters certain SMBus commands (for example, to prevent an errant application or virus from potentially damaging the battery subsystem). This is most easily accomplished by implementing the host interface controller through an embedded controller—as embedded controller can easily filter out potentially problematic commands.

Notice that an EC-SMB-HC interface will require the inclusion of the GLK method in its ACPI namespace if potentially contentious accesses to device resources are performed by non-OS code. See *_GLK (Global Lock)* for details on using the *_GLK* method.

12.9.1 Register Description

The EC-SMBus host interface is a flat array of registers that are arranged sequentially in the embedded controller address space.

12.9.1.1 Status Register, SMB_STS

This register indicates general status on the SMBus. This includes SMB-HC command completion status, alarm received status, and error detection status (the error codes are defined later in this section). This register is cleared to zeroes (except for the ALRM bit) whenever a new command is issued using a write to the protocol (SMB_PRTCL) register. This register is always written with the error code before clearing the protocol register. The SMB-HC query event (that is, an SMB-HC interrupt) is raised after the clearing of the protocol register.

Note: OSPM must ensure the ALRM bit is cleared after it has been serviced by writing '00' to the SMB_STS register.

Table 12.10: Status Register, SMB_STS

Bit7	Bit6	Bit5	Bit4	Bit3	Bit2	Bit1	Bit0
Done	ALRM	RES			STATUS		

Where:

DONE:	Indicates the last command has completed and no error.
ALRM:	Indicates an SMBus alarm message has been received.
RES:	<i>Reserved</i>
STATUS:	Indicates SMBus communication status for one of the reasons listed in the following table.

Table 12.11: SMBus Status Codes

Status Code	Name	Description
-------------	------	-------------

continues on next page

Table 12.11 – continued from previous page

00h	SMBus OK	Indicates the transaction has been successfully completed.
07h	SMBus Unknown Failure	Indicates failure because of an unknown SMBus error.
10h	SMBus Device Address Not Acknowledged	Indicates the transaction failed because the slave device address was not acknowledged.
11h	SMBus Device Error Detected	Indicates the transaction failed because the slave device signaled an error condition.
12h	SMBus Device Command Access Denied	Indicates the transaction failed because the SMBus host does not allow the specific command for the device being addressed. For example, the SMBus host might not allow a caller to adjust the Smart Battery Charger's output.
13h	SMBus Unknown Error	Indicates the transaction failed because the SMBus host encountered an unknown error.
17h	SMBus Device Access Denied	Indicates the transaction failed because the SMBus host does not allow access to the device addressed. For example, the SMBus host might not allow a caller to directly communicate with an SMBus device that controls the system's power planes.
18h	SMBus Timeout	Indicates the transaction failed because the SMBus host detected a timeout on the bus.
19h	SMBus Host Unsupported Protocol	Indicates the transaction failed because the SMBus host does not support the requested protocol.
1Ah	SMBus Busy	Indicates that the transaction failed because the SMBus host reports that the SMBus is presently busy with some other transaction. For example, the Smart Battery might be sending charging information to the Smart Battery Charger.
1Fh	SMBus PEC (CRC-8) Error	Indicates that a Packet Error Checking (PEC) error occurred during the last transaction.

All other error codes are reserved.

12.9.1.2 Protocol Register, SMB_PRTCL

This register determines the type of SMBus transaction generated on the SMBus. In addition to indicating the protocol type to the SMB-HC, a write to this register initiates the transaction on the SMBus. Notice that bit 7 of the protocol value is used to indicate whether packet error checking should be employed. A value of 1 (one) in this bit indicates that PEC format should be used for the specified protocol, and a value of 0 (zero) indicates the standard (non-PEC) format should be used.

Table 12.12: Protocol Register, SMB_PRTCL

Bit7	Bit6 to Bit0
PEC	PROTOCOL

Where the PROTOCOL values are as follows:

0x00	Controller Not In Use
0x01	<i>Reserved</i>
0x02	Write Quick Command
0x03	Read Quick Command
0x04	Send Byte
0x05	Receive Byte
0x06	Write Byte
0x07	Read Byte
0x08	Write Word
0x09	Read Word
0x0A	Write Block
0x0B	Read Block
0x0C	Process Call
0x0D	Block Write-Block Read Process Call

For example, the protocol value of 0x09 would be used to communicate to a device that supported the standard read word protocol. If this device also supported packet error checking for this protocol, a value of 0x89 (read word with PEC) could optionally be used. See the SMBus specification for more information on packet error checking.

When OSPM initiates a new command such as write to the SMB_PRTCL register, the SMBus controller first updates the SMB_STS register and then clears the SMB_PRTCL register. After the SMB_PRTCL register is cleared, the host controller query value is raised.

All other protocol values are reserved.

12.9.1.3 Address Register, SMB_ADDR

This register contains the 7-bit address to be generated on the SMBus. This is the first byte to be sent on the SMBus for all of the different protocols.

Table 12.13: Address Register, SMB_ADDR

Bit7 to Bit1	Bit0
ADDRESS (A6:A0)	RES

Where:

RES:	<i>Reserved</i>
ADDRESS:	7-bit SMBus address. This address is not zero-aligned (in other words, it is only a 7-bit address (A6:A0) that is aligned from bit 1-7).

12.9.1.4 Command Register, SMB_CMD

This register contains the command byte that will be sent to the target device on the SMBus and is used for the following protocols: send byte, write byte, write word, read byte, read word, process call, block read and block write. It is not used for the quick commands or the receive byte protocol, and as such, its value is a “don’t care” for those commands.

Table 12.14: Command Register, SMB_CMD

Bit7 to Bit0	COMMAND
--------------	---------

Where:

COMMAND	Command byte to be sent to SMBus device.
---------	--

12.9.1.5 Data Register Array, SMB_DATA[i], i=0-31

This bank of registers contains the remaining bytes to be sent or received in any of the different protocols that can be run on the SMBus. The SMB_DATA[i] registers are defined on a per-protocol basis and, as such, provide efficient use of register space.

Table 12.15: Data Register Array, SMB_DATA[i], i=0-31

Bit7 to Bit0	DATA
--------------	------

Where:

DATA	One byte of data to be sent or received (depending upon protocol).
------	--

12.9.1.6 Block Count Register, SMB_BCNT

This register contains the number of bytes of data present in the SMB_DATA[i] registers preceding any write block and following any read block transaction. The data size is defined on a per protocol basis.

Table 12.16: Block Count Register, SMB_BCNT

Bit7 to Bit5	Bit4 to Bit0
RES	BCNT

12.9.1.7 Alarm Address Register, SMB_ALARM_ADDR

This register contains the address of an alarm message received by the host controller, at slave address 0x8, from the SMBus master that initiated the alarm. The address indicates the slave address of the device on the SMBus that initiated the alarm message. The status of the alarm message is contained in the SMB_ALARM_DATAx registers. Once an alarm message has been received, the SMB-HC will not receive additional alarm messages until the ALRM status bit is cleared.

Table 12.17: Alarm Address Register, SMB_ALARM_ADDR

Bit7 to Bit1	Bit0
ADDRESS (A6:A0)	RES

Where:

RES:	<i>Reserved</i>
ADDRESS:	Slave address (A6:A0) of the SMBus device that initiated the SMBus alarm message.

12.9.1.8 Alarm Data Registers, SMB_ALARM_DATA[0], SMB_ALARM_DATA[1]

These registers contain the two data bytes of an alarm message received by the host controller, at slave address 0x8, from the SMBus master that initiated the alarm. These data bytes indicate the specific reason for the alarm message, such that OSPM can take actions. Once an alarm message has been received, the SMB-HC will not receive additional alarm messages until the ALRM status bit is cleared.

Table 12.18: Alarm Data Registers, SMB_ALARM_DATA[0], SMB_ALARM_DATA[1]

Bit7 to Bit0	DATA (D7:D0)
--------------	--------------

Where:

DATA	Data byte received in alarm message.
------	--------------------------------------

The alarm address and alarm data registers are not read by OSPM until the alarm status bit is set. OSPM driver then reads the 3 bytes, and clears the alarm status bit to indicate that the alarm registers are now available for the next event.

12.9.2 Protocol Description

This section describes how to initiate the different protocols on the SMBus through the interface described in *Register Description*. The registers should all be written with the appropriate values before writing the protocol value that starts the SMBus transaction. All transactions can be completed in one pass.

12.9.2.1 Write Quick

Data Sent:

SMB_ADDR:	Address of SMBus device.
SMB_PRTCL:	Write 0x02 to initiate the write quick protocol.

Data Returned:

SMB_STS:	Status code for transaction.
SMB_PRTCL:	0x00 to indicate command completion.

12.9.2.2 Read Quick

Data Sent:

SMB_ADDR:	Address of SMBus device.
SMB_PRTCL:	Write 0x03 to initiate the read quick protocol.

Data Returned:

SMB_STS:	Status code for transaction.
SMB_PRTCL:	0x00 to indicate command completion.

12.9.2.3 Send Byte

Data Sent:

SMB_ADDR:	Address of SMBus device.
SMB_CMD:	Command byte to be sent.
SMB_PRTCL:	Write 0x04 to initiate the send byte protocol, or 0x84 to initiate the send byte protocol with PEC.

Data Returned:

SMB_STS:	Status code for transaction.
SMB_PRTCL:	0x00 to indicate command completion.

12.9.2.4 Receive Byte

Data Sent:

SMB_ADDR:	Address of SMBus device.
SMB_PRTCL:	Write 0x05 to initiate the receive byte protocol, or 0x85 to initiate the receive byte protocol with PEC.

Data Returned:

SMB_DATA[0]:	Data byte received.
SMB_STS:	Status code for transaction.
SMB_PRTCL:	0x00 to indicate command completion.

12.9.2.5 Write Byte

Data Sent:

SMB_ADDR:	Address of SMBus device.
SMB_CMD:	Command byte to be sent.
SMB_DATA[0]:	Data byte to be sent.
SMB_PRTCL:	Write 0x06 to initiate the write byte protocol, or 0x86 to initiate the write byte protocol with PEC.

Data Returned:

SMB_STS:	Status code for transaction.
SMB_PRTCL:	0x00 to indicate command completion.

12.9.2.6 Read Byte

Data Sent:

SMB_ADDR:	Address of SMBus device.
SMB_CMD:	Command byte to be sent.
SMB_PRTCL:	Write 0x07 to initiate the read byte protocol, or 0x87 to initiate the read byte protocol with PEC.

Data Returned:

SMB_DATA[0]:	Data byte received.
SMB_STS:	Status code for transaction.
SMB_PRTCL:	0x00 to indicate command completion.

12.9.2.7 Write Word

Data Sent:

SMB_ADDR:	Address of SMBus device.
SMB_CMD:	Command byte to be sent.
SMB_DATA[0]:	Low data byte to be sent.
SMB_DATA[1]:	High data byte to be sent.
SMB_PRTCL:	Write 0x08 to initiate the write word protocol, or 0x88 to initiate the write word protocol with PEC.

Data Returned:

SMB_STS:	Status code for transaction.
SMB_PRTCL:	0x00 to indicate command completion.

12.9.2.8 Read Word

Data Sent:

SMB_ADDR:	Address of SMBus device.
SMB_CMD:	Command byte to be sent.
SMB_PRTCL:	Write 0x09 to initiate the read word protocol, or 0x89 to initiate the read word protocol with PEC.

Data Returned:

SMB_DATA[0]:	Low data byte received.
SMB_DATA[1]:	High data byte received.
SMB_STS:	Status code for transaction.
SMB_PRTCL:	0x00 to indicate command completion.

12.9.2.9 Write Block

Data Sent:

SMB_ADDR:	Address of SMBus device.
SMB_CMD:	Command byte to be sent.
SMB_DATA[0-31]:	Data bytes to write (1-32).
SMB_BCNT:	Number of data bytes (1-32) to be sent.
SMB_PRTCL:	Write 0x0A to initiate the write block protocol, or 0x8A to initiate the write block protocol with PEC.

Data Returned:

SMB_PRTCL:	0x00 to indicate command completion.
SMB_STS:	Status code for transaction.

12.9.2.10 Read Block

Data Sent:

SMB_ADDR:	Address of SMBus device.
SMB_CMD:	Command byte to be sent.
SMB_PRTCL:	Write 0x0B to initiate the read block protocol, or 0x8B to initiate the read block protocol with PEC.

Data Returned:

SMB_BCNT:	Number of data bytes (1-32) received.
SMB_DATA[0-31]:	Data bytes received (1-32).
SMB_STS:	Status code for transaction.
SMB_PRTCL:	0x00 to indicate command completion.

12.9.2.11 Process Call

Data Sent:

SMB_ADDR:	Address of SMBus device.
SMB_CMD:	Command byte to be sent.
SMB_DATA[0]:	Low data byte to be sent.
SMB_DATA[1]:	High data byte to be sent.
SMB_PRTCL:	Write 0x0C to initiate the process call protocol, or 0x8C to initiate the process call protocol with PEC.

Data Returned:

SMB_DATA[0]:	Low data byte received.
SMB_DATA[1]:	High data byte received.
SMB_STS:	Status code for transaction.
SMB_PRTCL:	0x00 to indicate command completion.

12.9.2.12 Block Write-Block Read Process Call

Data Sent:

SMB_ADDR:	Address of SMBus device.
SMB_CMD:	Command byte to be sent.
SMB_DATA[0-31]:	Data bytes to write (1-31).
SMB_BCNT:	Number of data bytes (1-31) to be sent.
SMB_PRTCL:	Write 0x0D to initiate the write block-read block process call protocol, or 0x8D to initiate the write block-read block process call protocol with PEC.

Data Returned:

SMB_BCNT:	Number of data bytes (1-31) received.
SMB_DATA[0-31]:	Data bytes received (1-31).
SMB_STS:	Status code for transaction.
SMB_PRTCL:	0x00 to indicate command completion.

Note: The following restrictions apply above: The aggregate data length of the write and read blocks must not exceed 32 bytes and each block (write and read) must contain at least 1 byte of data.

12.9.2.13 SMBus Register Set

The register set for the SMB-HC has the following format. All registers are 8 bit.

Table 12.19: SMB EC Interface

Location	Register Name	Description
BASE+0	SMB_PRTCL	Protocol register
BASE+1	SMB_STS	Status register
BASE+2	SMB_ADDR	Address register
BASE+3	SMB_CMD	Command register
BASE+4	SMB_DATA[0]	Data register zero
BASE+5	SMB_DATA[1]	Data register one
BASE+6	SMB_DATA[2]	Data register two
BASE+7	SMB_DATA[3]	Data register three
BASE+8	SMB_DATA[4]	Data register four
BASE+9	SMB_DATA[5]	Data register five
BASE+10	SMB_DATA[6]	Data register six
BASE+11	SMB_DATA[7]	Data register seven
BASE+12	SMB_DATA[8]	Data register eight
BASE+13	SMB_DATA[9]	Data register nine
BASE+14	SMB_DATA[10]	Data register ten
BASE+15	SMB_DATA[11]	Data register eleven
BASE+16	SMB_DATA[12]	Data register twelve
BASE+17	SMB_DATA[13]	Data register thirteen
BASE+18	SMB_DATA[14]	Data register fourteen
BASE+19	SMB_DATA[15]	Data register fifteen

continues on next page

Table 12.19 – continued from previous page

Location	Register Name	Description
BASE+20	SMB_DATA[16]	Data register sixteen
BASE+21	SMB_DATA[17]	Data register seventeen
BASE+22	SMB_DATA[18]	Data register eighteen
BASE+23	SMB_DATA[19]	Data register nineteen
BASE+24	SMB_DATA[20]	Data register twenty
BASE+25	SMB_DATA[21]	Data register twenty-one
BASE+26	SMB_DATA[22]	Data register twenty-two
BASE+27	SMB_DATA[23]	Data register twenty-three
BASE+28	SMB_DATA[24]	Data register twenty-four
BASE+29	SMB_DATA[25]	Data register twenty-five
BASE+30	SMB_DATA[26]	Data register twenty-six
BASE+31	SMB_DATA[27]	Data register twenty-seven
BASE+32	SMB_DATA[28]	Data register twenty-eight
BASE+33	SMB_DATA[29]	Data register twenty-nine
BASE+34	SMB_DATA[30]	Data register thirty
BASE+35	SMB_DATA[31]	Data register thirty-one
BASE+36	SMB_BCNT	Block Count Register
BASE+37	SMB_ALRM_ADDR	Alarm address
BASE+38	SMB_ALRM_DATA[0]	Alarm data register zero
BASE+39	SMB_ALRM_DATA[1]	Alarm data register one

12.10 SMBus Devices

The embedded controller interface provides the system with a standard method to access devices on the SMBus. It does not define the data and/or access protocol(s) used by any particular SMBus device. Further, the embedded controller can (and probably will) serve as a gatekeeper to prevent accidental or malicious access to devices on the SMBus.

Some SMBus devices are defined by their address and a specification that describes the data and the protocol used to access that data. For example, the Smart Battery System devices are defined by a series of specifications including:

- Smart Battery Data specification
- Smart Battery Charger specification
- Smart Battery Selector specification
- Smart Battery System Manager specification

The embedded controller can also be used to emulate (in part or totally) any SMBus device.

12.10.1 SMBus Device Access Restrictions

In some cases, the embedded controller interface will not allow access to a particular SMBus device. Some SMBus devices can and do communicate directly between themselves. Unexpected accesses can interfere with their normal operation and cause unpredictable results.

12.10.2 SMBus Device Command Access Restriction

There are cases where part of an SMBus device's commands are public while others are private. Extraneous attempts to access these commands might cause interference with the SMBus device's normal operation.

The Smart Battery and the Smart Battery Charger are good examples of devices that should not have their entire command set exposed. The Smart Battery commands the Smart Battery Charger to supply a specific charging voltage and charging current. Attempts by anyone to alter these values can cause damage to the battery or the mobile system. To protect the system's integrity, the embedded controller interface can restrict access to these commands by returning one of the following error codes: Device Command Access Denied (0x12) or Device Access Denied (0x17).

12.11 Defining an Embedded Controller Device in ACPI Namespace

An embedded controller device is created using the named device object. The embedded controller's device object requires the following elements:

Table 12.20: Embedded Controller Device Object Control Methods

Object	Description
_CRS	Named object that returns the Embedded Controller's current resource settings. Embedded Controllers are considered static resources; hence only return their defined resources. The embedded controller resides only in system I/O or memory space. The first address region returned is the data port, and the second address region returned is the status/command port for the embedded controller. If the EC is used on a HW-Reduced ACPI platform, a third resource is required, which is the GPIO Interrupt Connection resource for the EC's SCI Interrupt. CRS is a standard device configuration control method defined in <i>_CRS (Current Resource Settings)</i> .
_HID	Named object that provides the Embedded Controller's Plug and Play identifier. This value is set to PNP0C09. _HID is a standard device configuration control method defined in <i>_HID (Hardware ID)</i> .
_GPE	Named Object that evaluates to either an integer or a package. If _GPE evaluates to an integer, the value is the bit assignment of the SCI interrupt within the GPEX_STS register of a GPE block described in the FADT that the embedded controller will trigger. If _GPE evaluates to a package, then that package contains two elements. The first is an object reference to the GPE Block device that contains the GPE register that will be triggered by the embedded controller. The second element is numeric (integer) that specifies the bit assignment of the SCI interrupt within the GPEX_STS register of the GPE Block device referenced by the first element in the package. This control method is specific to the embedded controller. This method is not required on Hardware-reduced ACPI platforms.
_DSM	Device Specific Method that allows a supported OSV to negotiate the platform FW preferred interactions for the onboard embedded controller.

Arguments (Function 1):

- Arg0: A Buffer containing the UUID = {ecc0d5e9-3ee7-4f53-8c8f-766b839dddce}
- Arg1: An Integer containing the Revision ID = 0
- Arg2: An Integer containing the Function Index = 1
- Arg3: Empty package (not used)

Return Value (Function 1):

{FW-Granted Min Burst Length} A 32-bit buffer containing the minimum number of bytes the platform FW has granted to be performed in ACPI Burst Mode when communicating with the EC opregion (a value of 0 or all FFs is reserved).

Implementation Note:

The intent of _DSM Function 1 is to optimize the OSV's EC Opreion accesses performed in ACPI Burst Mode in a regression-safe way. For legacy platforms that do not implement this change, the existing ACPI Burst Mode behavior will remain unchanged, resolving concerns for regression. Platforms that do implement EC _DSM Function 1 must do so only after confirming that the platform takes no dependency on ACPI burst mode for opreion accesses less than the return value of _DSM Function 1.

After the OSV has discovered both an ACPI EC namespace definition and a paired opreion definition under that namespace, a supported OSV must invoke this _DSM before communicating with that opreion.

Other OSV changes are optional and implementation specific.

Example:

```
Device (H_EC) {
  Name (_HID, EISAID("PNP0C09"))

  // _DSM - Device Specific Method
  //
  // Arg0: UUID Unique function identifier
  // Arg1: Integer Revision Level
  // Arg2: Integer Function Index (0 = Return Supported Functions)
  // Arg3: Package Parameters
  Function(_DSM, {IntObj, BuffObj}, {BuffObj, IntObj, IntObj, PkgObj})
  {
    switch(Arg0)
    {
      case(ToUUID("ecc0d5e9-3ee7-4f53-8c8f-766b839dddce"))
      {
        switch(Arg2)
        {
          //
          // Function 0: Return supported functions, based on revision
          //
          case(0)
          {
            switch(Arg1)
            {
              // revision 0: function 1 is supported
              case(0) {return (Buffer() {0x1})}
            }
            // revision 1+: No function yet supported
            return (Buffer() {0x0})
          }
          //
          // Function 1: Return Platform-FW Granted min number of bytes to use burst
          // mode for
          //
          case(1)
          {
            ... Platform FW logic to get min number of bytes to use Burst Mode for ...
            ... It is recommended to return a value larger than 1 ...
            Return(Buffer() {0x2})
          }
          default {BreakPoint }
        }
      }
    }
  }
  //

```

(continues on next page)

(continued from previous page)

```

// If not one of the UUIDs we recognize, then return a buffer
// with bit 0 set to 0 indicating no functions supported.
//
return(Buffer() {0})
}
...
...
}

```

12.11.1 Example: EC Definition ASL Code

Example ASL code that defines an embedded controller device is shown below:

```

Device (EC0) {
                                // PnP ID
    Name (_HID, EISAID("PNP0C09"))
                                // Returns the "Current Resources" of EC
    Name (_CRS,
        ResourceTemplate() { // port 0x62 and 0x66
            IO(Decode16, 0x62, 0x62, 0, 1),
            IO(Decode16, 0x66, 0x66, 0, 1)
            /* For HW-Reduced ACPI Platforms, include a GPIO Interrupt Connection
↳resource,
            e.g. GPIO controller #2, pin 43.
            GpioInt(Edge, ActiveHigh, ExclusiveAndWake, PullUp 0, "\\_SB.GPI2") {43}
            */
        }
    )
                                // Define that the EC SCI is bit 0 of the GP_
↳STS register
    Name (_GPE, 0)                // Not required for HW-Reduced ACPI platforms
    OperationRegion(ECOR, EmbeddedControl, 0, 0xFF)
    Field(ECOR, ByteAcc, Lock, Preserve) {
                                // Field definitions go here
    }
}

```

12.12 Defining an EC SMBus Host Controller in ACPI Namespace

An EC-SMB-HC device is defined using the named device object. The EC-SMB-HC's device object requires the following elements:

Table 12.21: EC SMBus HC Device Objects

Object	Description
_HID	Named object that provides the EC-SMB-HC's Plug and Play identifier. This value is set to ACPI0001. _HID is a standard device configuration control method defined in <i>_HID (Hardware ID)</i> .
_EC	Named object that evaluates to a WORD that defines the SMBus attributes needed by the SMBus driver. _EC is the Embedded Controller Offset Query Control Method. The most significant byte is the address offset in embedded controller space of the SMBus controller; the least significant byte is the query value for all SMBus events.

12.12.1 Example: EC SMBus Host Controller ASL-Code

Example ASL code that defines an SMB-HC from within an embedded controller device is shown below:

```
Device (EC0)
{
    Name (_HID, EISAID("PNP0C09"))
    Name (_CRS, ResourceTemplate()
    {
        IO(Decode16, 0x62, 0x62, 0, 1), // Status port
        IO(Decode16, 0x66, 0x66, 0, 1) // command port
    })
    Name (_GPE, 0)

    Device (SMB0)
    {
        Name (_HID, "ACPI0001") // EC-SMB-HC
        Name (_UID, 0) // Unique device identifier
        Name (_EC, 0x2030) // EC offset 0x20, query bit 0x30
        :
    }
    Device (SMB1)
    {
        Name (_HID, "ACPI0001") // EC-SMB-HC
        Name (_UID, 1) // Unique device identifier
        Name (_EC, 0x8031) // EC offset 0x80, query bit 0x31
        :
    }
} // end of EC0.
```

ACPI SYSTEM MANAGEMENT BUS INTERFACE SPECIFICATION

This section describes the System Management Bus (SMBus) generic address space and the use of this address space to access SMBus devices from AML.

Unlike other address spaces, SMBus operation regions are inherently non-linear, where each offset within an SMBus address space represents a variable-sized (from 0 to 32 bytes) field. Given this uniqueness, SMBus operation regions include restrictions on their field definitions and require the use of an SMBus-specific data buffer for all transactions.

The SMBus interface presented in this section is intended for use with any hardware implementation compatible with the SMBus specification. SMBus hardware is broadly classified as either non-EC-based or EC-based. EC-based SMBus implementations comply with the standard register set defined in *ACPI Embedded Controller Interface Specification*.

Non-EC SMBus implementations can employ any hardware interface and are typically used for their cost savings when SMBus security is not required. Non-EC-based SMBus implementations require the development of hardware specific drivers for each OS implementation. See *Declaring SMBus Host Controller Objects* for more information.

Support of the SMBus generic address space by ACPI-compatible operating systems is optional. As such, the Smart Battery System Implementer's Forum (SBS-IF) has defined an SMBus interface based on a standard set of control methods. This interface is documented in the SMBus Control Method Interface Specification at <http://smbus.org/specs/> (or see <http://uefi.org/acpi> under the heading "Smart Battery System Components and SMBus Specification").

13.1 SMBus Overview

SMBus is a two-wire interface based upon the I²C protocol. The SMBus is a low-speed bus that provides positive addressing for devices, as well as bus arbitration. For more information, refer to the complete set of SMBus specifications published by the SBS-IF.

13.1.1 SMBus Slave Addresses

Slave addresses are specified using a 7-bit non-shifted notation. For example, the slave address of the Smart Battery Selector device would be specified as 0x0A (1010b), not 0x14 (10100b) as might be found in other documents. These two different forms of addresses result from the format in which addresses are transmitted on the SMBus.

During transmission over the physical SMBus, the slave address is formatted in an 8-bit block with bits 7-1 containing the address and bit 0 containing the read/write bit. ASL code, on the other hand, presents the slave address simply as a 7-bit value making it the responsibility of the OS (driver) to shift the value if needed. For example, the ASL value would have to be shifted left 1 bit before being written to the SMB_ADDR register in the EC based SMBus as described in *Address Register, SMB_ADDR*.

13.1.2 SMBus Protocols

There are seven possible command protocols for any given SMBus slave device, and a device may use any or all of the protocols to communicate. The protocols and associated access type indicators are listed below. Notice that the protocols values are similar to those defined for the EC-based SMBus in *Protocol Register, SMB_PRTCL* except that protocol pairs (for example, Read Byte, Write Byte) have been joined.

Table 13.1: SMBus Protocol Types

Value	Type	Description
0x02	SMBQuick	SMBus Read/Write Quick Protocol
0x04	SMBSendReceive	SMBus Send/Receive Byte Protocol
0x06	SMBByte	SMBus Read/Write Byte Protocol
0x08	SMBWord	SMBus Read/Write Word Protocol
0x0A	SMBBlock	SMBus Read/Write Block Protocol
0x0C	SMBProcessCall	SMBus Process Call Protocol
0x0D	SMBBlockProcessCall	SMBus Write Block-Read Block Process Call Protocol

All other protocol values are reserved.

Notice that bit 7 of the protocol value is used by this interface to indicate to the SMB-HC whether or not packet error checking (PEC) should be employed for a transaction. Packet error checking is described in section 7.4 of the *System Management Bus Specification, Version 1.1*. This highly desirable capability improves the reliability and robustness of SMBus communications.

The bit encoding of the protocol value is shown below. For example, the value 0x86 would be used to specify the PEC version of the SMBus Read/Write Byte protocol.

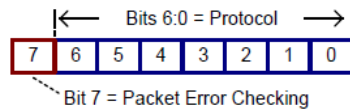

Fig. 13.1: Bit Encoding Example

Notice that bit 0 of the protocol value is always zero (even number hexadecimal values). In a manner similar to the slave address, software that implements the SMBus interface is responsible for setting this bit to indicate whether the transaction is a read (for example, Read Byte) or write (for example, Write Byte) operation.

For example, software implanting this interface for EC-SMBus segments would set bit 0 for read transactions. For the SMBByte protocol (0x06), this would result in the value 0x07 being placed into the SMB_PRTCL register (or 0x87 if PEC is requested) for write transactions.

13.1.3 SMBus Status Codes

The use of status codes helps AML determine whether an SMBus transaction was successful. In general, a status code of zero indicates success, while a non-zero value indicates failure. The SMBus interface uses the same status codes defined for the EC-SMBus (see *Status Register, SMB_STS*).

13.1.4 SMBus Command Values

SMBus devices may optionally support up to 256 device-specific commands. For these devices, each command value supported by the device is modeled by this interface as a separate virtual register. Protocols that do not transmit a command value (for example, Read/Write Quick and Send/Receive Byte) are modeled using a single virtual register (with a command value = 0x00).

13.2 Accessing the SMBus from ASL Code

The following sections demonstrate how to access and use the SMBus from ASL code.

13.2.1 Declaring SMBus Host Controller Objects

EC-based SMBus 1.0-compatible HCs should be modeled in the ACPI namespace as described in *Defining an Embedded Controller Device in ACPI Namespace*, “Defining an Embedded Controller SMBus Host Controller in ACPI Namespace.” An example definition is given below. Using the HID value “ACPI0001” identifies that this SMB-HC is implemented on an embedded controller using the standard SMBus register set defined in *SMBus Host Controller Interface via Embedded Controller*.

```
Device (SMB0)
{
    Name(_HID, "ACPI0001") // EC-based SMBus 1.0 compatible Host Controller
    Name(_EC, 0x2030) // EC offset 0x20, query bit 0x30
    :
}
```

EC-based SMBus 2.0-compatible host controllers should be defined similarly in the namespace as follows:

```
Device (SMB0)
{
    Name(_HID, "ACPI0005") // EC-based SMBus 2.0 compatible Host Controller
    Name(_EC, 0x2030) // EC offset 0x20, query bit 0x30
    :
}
```

Non-EC-based SMB-HCs should be modeled in a manner similar to the EC-based SMBus HC. An example definition is given below. These devices use a vendor-specific hardware identifier (HID) to specify the type of SMB-HC (do not use “ACPI0001” or “ACPI0005”). Using a vendor-specific HID allows the correct software to be loaded to service this segment’s SMBus address space.

```
Device (SMB0)
{
    Name(_HID, "<vendor-specific hid>") // Vendor-Specific HID
    :
}
```

Regardless of the type of hardware, some OS software element (for example, the SMBus HC driver) must register with OSPM to support all SMBus operation regions defined for the segment. This software allows the generic SMBus interface defined in this section to be used on a specific hardware implementation by translating between the conceptual (for example, SMBus address space) and physical (for example, process of writing/reading registers) models. Because of this linkage, SMBus operation regions must be defined immediately within the scope of the corresponding SMBus device.

13.2.2 Declaring SMBus Devices

The SMBus, as defined by the *SMBus Specifications* <<http://smbus.org/specs/>>, is not an enumerable bus. As a result, an SMBus 1.0-compatible SMB-HC driver cannot discover child devices on the SMBus and load the appropriate corresponding device drivers. As such, SMBus 1.0-compatible devices are declared in the ACPI namespace, in like manner to other motherboard devices, and enumerated by OSPM.

The SMBus 2.0 specification adds mechanisms enabling device enumeration on the bus while providing compatibility with existing devices. ACPI defines and associates the “ACPI0005” HID value with an EC-based SMBus 2.0-compatible host controller. OSPM will enumerate SMBus 1.0-compatible devices when declared in the namespace under an SMBus 2.0-compatible host controller.

The responsibility for the definition of ACPI namespace objects, required by an SMBus 2.0-compatible host controller driver to enumerate non-bus-enumerable devices, is relegated to the Smart Battery System Implementers Forum. See the SMBus Specifications at the link mentioned above.

Starting in ACPI 2.0, `_ADR` is used to associate SMBus devices with their lowest SMBus slave address.

13.2.3 Declaring SMBus Operation Regions

Each SMBus operation region definition identifies a single SMBus slave address. Operation regions are defined only for those SMBus devices that need to be accessed from AML. As with other regions, SMBus operation regions are only accessible via the Field term (see *Declaring SMBus Devices*).

This interface models each SMBus device as having a 256-byte linear address range. Each byte offset within this range corresponds to a single command value (for example, byte offset 0x12 equates to command value 0x12), with a maximum of 256 command values. By doing this, SMBus address spaces appear linear and can be processed in a manner similar to the other address space types.

The syntax for the OperationRegion term (from *OperationRegion (Declare Operation Region)*) is described below.

```
OperationRegion (
    RegionName,           // NameString
    RegionSpace,         // RegionSpaceKeyword
    Offset,              // TermArg=>Integer
    Length               // TermArg=>Integer
)
```

Where:

- *RegionName* specifies a name for this slave device (for example, “SBD0”).
- *RegionSpace* must be set to **SMBus** (operation region type value 0x04).
- *Offset* is a word-sized value specifying the slave address and initial command value offset for the target device. The slave address is stored in the high byte and the command value offset is stored in the low byte. For example, the value 0x4200 would be used for an SMBus device residing at slave address 0x42 with an initial command value offset of zero (0).
- *Length* is set to the 0x100 (256), representing the maximum number of possible command values, for regions with an initial command value offset of zero (0). The difference of these two values is used for regions with non-zero offsets. For example, a region with an Offset value of 0x4210 would have a corresponding Length of 0xF0 (0x100 minus 0x10).

For example, the Smart Battery Subsystem (illustrated below) consists of the Smart Battery Charger at slave address 0x09, the Smart Battery System Manager at slave address 0x0A, and one or more batteries (multiplexed) at slave address 0x0B. (Notice that Figure 13-2 represents the logical connection of a Smart Battery Subsystem. The actual physical connections of the Smart Battery(s) and the Smart Battery Charger are made through the Smart Battery

System Manager.) All devices support the Read/Write Word protocol. Batteries also support the Read/Write Block protocol.

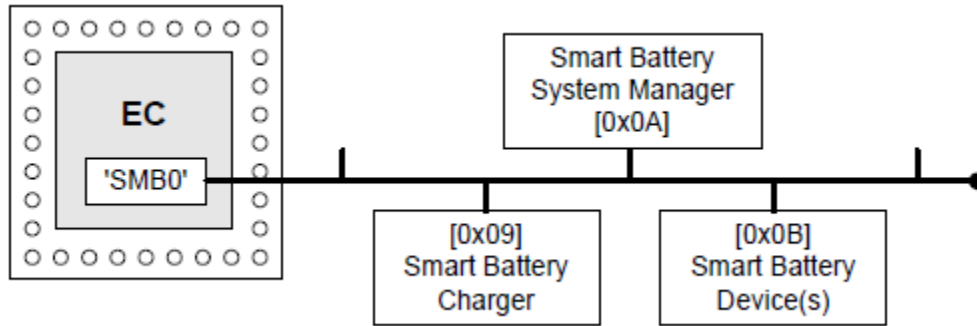

Fig. 13.2: Smart Battery Subsystem Devices

The following ASL code shows the use of the OperationRegion term to describe these SMBus devices:

```
Device (SMB0)
{
    Name(_HID, "ACPI0001") // EC-SMBus Host Controller
    Name(_EC, 0x2030) // EC offset 0x20, query bit 0x30

    OperationRegion(SBC0, SMBus, 0x0900, 0x100) // Smart Battery Charger
    OperationRegion(SBS0, SMBus, 0x0A00, 0x100) // Smart Battery Selector
    OperationRegion(SBD0, SMBus, 0x0B00, 0x100) // Smart Battery Device(s)
    :
}
```

Notice that these operation regions in this example are defined within the immediate context of the ‘owning’ EC-SMBus device. Each definition corresponds to a separate slave address (device), and happens to use an initial command value offset of zero (0).

13.2.4 Declaring SMBus Fields

As with other regions, SMBus operation regions are only accessible via the Field term. Each field element is assigned a unique command value and represents a virtual register on the targeted SMBus device.

The syntax for the Field term (from *Event (Declare Event Synchronization Object)*) is described below.

```
Field(
    RegionName, // NameString=>OperationRegion
    AccessType, // AccessTypeKeyword
    LockRule, // LockRuleKeyword
    UpdateRule // UpdateRuleKeyword - *ignored*
) {FieldUnitList}
```

Where:

- *RegionName* specifies the operation region name previously defined for the device.
- *AccessType* must be set to **BufferAcc**. This indicates that access to field elements will be done using a region-specific data buffer. For this access type, the field handler is not aware of the data buffer’s contents which may be of any size. When a field of this type is used as the source argument in an operation it simply evaluates to a buffer. When used as the destination, however, the buffer is passed bi-directionally to allow data to be returned

from write operations. The modified buffer then becomes the execution result of that operation. This is slightly different than the normal case in which the execution result is the same as the value written to the destination. Note that the source is never changed, since it could be a read only object (see *Declaring and Using an SMBus Data Buffer* and *ASL Opcode Terms*).

- *LockRule* indicates if access to this operation region requires acquisition of the Global Lock for synchronization. This field should be set to Lock on system with firmware that may access the SMBus, and **NoLock** otherwise.
- *UpdateRule* is not applicable to SMBus operation regions since each virtual register is accessed in its entirety. This field is ignored for all SMBus field definitions.

SMBus operation regions require that all field elements be declared at command value granularity. This means that each virtual register cannot be broken down to its individual bits within the field definition.

Access to sub-portions of virtual registers can be done only outside of the field definition. This limitation is imposed both to simplify the SMBus interface and to maintain consistency with the physical model defined by the SMBus specification.

SMBus protocols are assigned to field elements using the *AccessAs* term within the field definition. The syntax for this term (from *ASL Root and Secondary Terms*) is described below.

```
AccessAs (
    AccessType, //AccessTypeKeyword
    AccessAttribute //Nothing \ | ByteConst \ | AccessAttribKeyword
)
```

Where:

- *AccessType* must be set to **BufferAcc**.
- *AccessAttribute* indicates the SMBus protocol to assign to command values that follow this term. See *SMBus Protocols* for a listing of the SMBus protocol types and values.

An *AccessAs* term must appear as the first entry in a field definition to set the initial SMBus protocol for the field elements that follow. A maximum of one SMBus protocol may be defined for each field element. Devices supporting multiple protocols for a single command value can be modeled by specifying multiple field elements with the same offset (command value), where each field element is preceded by an *AccessAs* term specifying an alternate protocol.

For example, the register at command value 0x08 for a Smart Battery device (illustrated below) represents a word value specifying the battery temperature (in degrees Kelvin), while the register at command value 0x20 represents a variable-length (0 to 32 bytes) character string specifying the name of the company that manufactured the battery.

The following ASL code shows the use of the *OperationRegion*, *Field*, *AccessAs*, and *Offset* terms to represent these Smart Battery device virtual registers:

```
OperationRegion(SBD0, SMBus, 0x0B00, 0x0100)
Field(SBD0, BufferAcc, NoLock, Preserve)
{
    AccessAs(BufferAcc, SMBWord) // Use the SMBWord protocol for the following...
    MFGA, 8, // ManufacturerAccess() [command value 0x00]
    RCAP, 8, // RemainingCapacityAlarm() [command value 0x01]
    Offset(0x08) // Skip to command value 0x08...
    BTMP, 8, // Temperature() [command value 0x08]
    Offset(0x20) // Skip to command value 0x20...
    AccessAs(BufferAcc, SMBBlock) // Use the SMBBlock protocol for the following...
    MFGN, 8, // ManufacturerName() [command value 0x20]
    DEVN, 8 // DeviceName() [command value 0x21]
}
```

Notice that command values are equivalent to the field element's byte offset (for example, MFGA=0, RCAP=1, BTMP=8). The *AccessAs* term indicates which SMBus protocol to use for each command value.

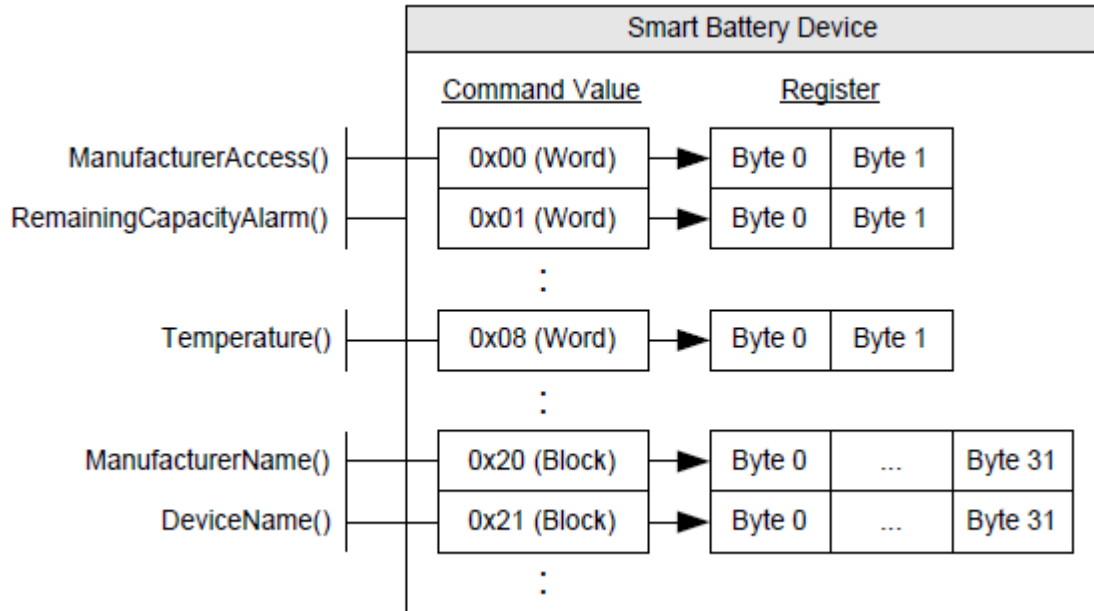

Fig. 13.3: Smart Battery Device Virtual Registers

13.2.5 Declaring and Using an SMBus Data Buffer

The use of a data buffer for SMBus transactions allows AML to receive status and data length values, as well as making it possible to implement the Process Call protocol. As previously mentioned, the **BufferAcc** access type is used to indicate to the field handler that a region-specific data buffer will be used.

For SMBus operation regions, this data buffer is defined as a fixed-length 34-byte buffer that, if represented using a 'C'-styled declaration, would be modeled as follows:

```
typedef struct
{
    BYTE Status;           // Byte 0 of the data buffer
    BYTE Length;          // Byte 1 of the data buffer
    BYTE[32] Data;        // Bytes 2 through 33 of the data buffer
}
```

Where:

- *Status* (byte 0) indicates the status code of a given SMBus transaction. See *SMBus Status Codes* for more information.
- *Length* (byte 1) specifies the number of bytes of valid data that exists in the data buffer. Use of this field is only defined for the Read/Write Block protocol, where valid Length values are 0 through 32. For other protocols—where the data length is implied by the protocol—this field is reserved.
- *Data* (bytes 33-2) represents a 32-byte buffer, and is the location where actual data is stored.

For example, the following ASL shows the use of the SMBus data buffer for performing transactions to a Smart Battery device. This code is based on the example ASL presented in *Declaring SMBus Fields* which lists the operation region and field definitions for the Smart Battery device.

```
/* Create the SMBus data buffer */
Name (BUFF, Buffer (34) {})           // Create SMBus data buffer as BUFF
```

(continues on next page)

(continued from previous page)

```

CreateByteField(BUFF, 0x00, OB1)    // OB1 = Status (Byte)
CreateByteField(BUFF, 0x01, OB2)    // OB2 = Length (Byte)
CreateWordField(BUFF, 0x02, OB3)    // OB3 = Data (Word - Bytes 2 & 3)
CreateField(BUFF, 0x10, 256, OB4)   // OB4 = Data (Block - Bytes 2-33)

/* Read the battery temperature */
Store(BTMP, BUFF) // Invoke Read Word transaction
If(LEqual(OB1, 0x00)) // Successful?
{
    // OB3 = Battery temperature in 1/10th degrees_
    ←Kelvin
}

/* Read the battery manufacturer name */
Store(MFGN, BUFF) // Invoke Read Block transaction
If(LEqual(OB1, 0x00)) // Successful?
{
    // OB2 = Length of the manufacturer name
    // OB4 = Manufacturer name (as a counted string)
}

```

Notice the use of the **CreateField** primitives to access the data buffer's sub-elements (*Status*, *Length*, and *Data*), where *Data* (bytes 33-2) is 'typecast' as both word (OB3) and block (OB4) data.

The example above demonstrates the use of the Store() operator to invoke a Read Block transaction to obtain the name of the battery manufacturer. Evaluation of the source operand (MFGN) results in a 34-byte buffer that gets copied by Store() to the *destination* buffer (BUFF).

Capturing the results of a write operation, for example to check the status code, requires an additional Store() operator, as shown below.

```

Store(Store(BUFF, MFGN), BUFF) // Invoke Write Block transaction
If(LEqual(OB1, 0x00)) {...} // Transaction successful?

```

Note that the outer Store() copies the results of the Write Block transaction back into BUFF. This is the nature of BufferAcc's bi-directionality described in *Declaring SMBus Fields*. It should be noted that storing (or parsing) the result of an SMBus Write transaction is not required although useful for ascertaining the outcome of a transaction.

SMBus Process Call protocols require similar semantics due to the fact that only destination operands are passed bi-directionally. These transactions require the use of the double-Store() semantics to properly capture the return results.

13.3 Using the SMBus Protocols

This section provides information and examples on how each of the SMBus protocols can be used to access SMBus devices from AML.

13.3.1 Read/Write Quick (SMBQuick)

The SMBus Read/Write Quick protocol (SMBQuick) is typically used to control simple devices using a device-specific binary command (for example, ON and OFF). Command values are not used by this protocol and thus only a single element (at offset 0) can be specified in the field definition. This protocol transfers no data.

The following ASL code illustrates how a device supporting the Read/Write Quick protocol should be accessed:

```

OperationRegion(SMBD, SMBus, 0x4200, 0x100) // SMBus device at slave address 0x42
Field(SMBD, BufferAcc, NoLock, Preserve)
{
    AccessAs(BufferAcc, SMBQuick)           // Use the SMBus Read/Write Quick protocol
    FLD0, 8                                 // Virtual register at command value 0.
}

/* Create the SMBus data buffer */

Name(BUFF, Buffer(34){})                   // Create SMBus data buffer as BUFF
CreateByteField(BUFF, 0x00, OB1)          // OB1 = Status (Byte)

/* Signal device (e.g. OFF) */
Store(FLD0, BUFF)                         // Invoke Read Quick transaction
If(LEqual(OB1, 0x00)) {...}              // Successful?

/* Signal device (e.g. ON) */
Store(BUFF, FLD0) // Invoke Write Quick transaction

```

In this example, a single field element (FLD0) at offset 0 is defined to represent the protocol's read/write bit. Access to FLD0 will cause an SMBus transaction to occur to the device. Reading the field results in a Read Quick, and writing to the field results in a Write Quick. In either case data is not transferred—access to the register is simply used as a mechanism to invoke the transaction.

13.3.2 Send/Receive Byte (SMBSendReceive)

The SMBus Send/Receive Byte protocol (SMBSendReceive) transfers a single byte of data. Like Read/Write Quick, command values are not used by this protocol and thus only a single element (at offset 0) can be specified in the field definition.

The following ASL code illustrates how a device supporting the Send/Receive Byte protocol should be accessed:

```

OperationRegion(SMBD, SMBus, 0x4200, 0x100) // SMBus device at slave address 0x42
Field(SMBD, BufferAcc, NoLock, Preserve)
{
    AccessAs(BufferAcc, SMBSendReceive)     // Use the SMBus Send/Receive Byte protocol
    FLD0, 8                                 // Virtual register at command value 0.
}

// Create the SMBus data buffer

```

(continues on next page)

(continued from previous page)

```

Name(BUFF, Buffer(34){}) // Create SMBus data buffer as BUFF
CreateByteField(BUFF, 0x00, STAT) // STAT = Status (Byte)
CreateByteField(BUFF, 0x02, DATA) // DATA = Data (Byte)

// Receive a byte of data from the device

Store(FLD0, BUFF) // Invoke a Receive Byte transaction

If(LEqual(STAT, 0x00)) // Successful?
{
    // DATA = Received byte...
}

// Send the byte '0x16' to the device
Store(0x16, DATA) // Save 0x16 into the data buffer
Store(BUFF, FLD0) // Invoke a Send Byte transaction

```

In this example, a single field element (FLD0) at offset 0 is defined to represent the protocol's data byte. Access to FLD0 will cause an SMBus transaction to occur to the device. Reading the field results in a Receive Byte, and writing to the field results in a Send Byte.

13.3.3 Read/Write Byte (SMBByte)

The SMBus Read/Write Byte protocol (SMBByte) also transfers a single byte of data. But unlike Send/Receive Byte, this protocol uses a command value to reference up to 256 byte-sized virtual registers.

The following ASL code illustrates how a device supporting the Read/Write Byte protocol should be accessed:

```

OperationRegion(SMBD, SMBus, 0x4200, 0x100) // SMBus device at slave address 0x42
Field(SMBD, BufferAcc, NoLock, Preserve)
{
    AccessAs(BufferAcc, SMBByte) // Use the SMBus Read/Write Byte protocol
    FLD0, 8, // Virtual register at command value 0.
    FLD1, 8, // Virtual register at command value 1.
    FLD2, 8, // Virtual register at command value 2.
}

// Create the SMBus data buffer
Name(BUFF, Buffer(34){}) // Create SMBus data buffer as BUFF
CreateByteField(BUFF, 0x00, STAT) // STAT = Status (Byte)
CreateByteField(BUFF, 0x02, DATA) // DATA = Data (Byte)

// Read a byte of data from the device using command value 1
Store(FLD1, BUFF) // Invoke a Read Byte transaction
If(LEqual(STAT, 0x00)) // Successful?
{
    // DATA = Byte read from FLD1...
}

// Write the byte '0x16' to the device using command value 2
Store(0x16, DATA) // Save 0x16 into the data buffer
Store(BUFF, FLD2) // Invoke a Write Byte transaction

```

In this example, three field elements (FLD0, FLD1, and FLD2) are defined to represent the virtual registers for command values 0, 1, and 2. Access to any of the field elements will cause an SMBus transaction to occur to the device.

Reading FLD1 results in a Read Byte with a command value of 1, and writing to FLD2 results in a Write Byte with command value 2.

13.3.4 Read/Write Word (SMBWord)

The SMBus Read/Write Word protocol (SMBWord) transfers 2 bytes of data. This protocol also uses a command value to reference up to 256 word-sized virtual device registers.

The following ASL code illustrates how a device supporting the Read/Write Word protocol should be accessed:

```

OperationRegion(SMBD, SMBus, 0x4200, 0x100) // SMBus device at slave address 0x42
Field(SMBD, BufferAcc, NoLock, Preserve)
{
    AccessAs(BufferAcc, SMBWord)           // Use the SMBus Read/Write Word protocol
    FLD0, 8,                               // Virtual register at command value 0.
    FLD1, 8,                               // Virtual register at command value 1.
    FLD2, 8,                               // Virtual register at command value 2.
}

// Create the SMBus data buffer
Name(BUFF, Buffer(34){})                  // Create SMBus data buffer as BUFF
CreateByteField(BUFF, 0x00, STAT)        // STAT = Status (Byte)
CreateWordField(BUFF, 0x02, DATA)       // DATA = Data (Word)

// Read two bytes of data from the device using command value 1
Store(FLD1, BUFF)                        // Invoke a Read Word transaction
If(LEqual(STAT, 0x00))                  // Successful?
{
    // DATA = Word read from FLD1...
}

// Write the word '0x5416' to the device using command value 2
Store(0x5416, DATA)                     // Save 0x5416 into the data buffer
Store(BUFF, FLD2)                        // Invoke a Write Word transaction

```

In this example, three field elements (FLD0, FLD1, and FLD2) are defined to represent the virtual registers for command values 0, 1, and 2. Access to any of the field elements will cause an SMBus transaction to occur to the device. Reading FLD1 results in a Read Word with a command value of 1, and writing to FLD2 results in a Write Word with command value 2.

Notice that although accessing each field element transmits a word (16 bits) of data, the fields are listed as 8 bits each. The actual data size is determined by the protocol. Every field element is declared with a length of 8 bits so that command values and byte offsets are equivalent.

13.3.5 Read/Write Block (SMBBlock)

The SMBus Read/Write Block protocol (SMBBlock) transfers variable-sized (0-32 bytes) data. This protocol uses a command value to reference up to 256 block-sized virtual registers.

The following ASL code illustrates how a device supporting the Read/Write Block protocol should be accessed:

```

OperationRegion(SMBD, SMBus, 0x4200, 0x100) // SMBus device at slave address 0x42
Field(SMBD, BufferAcc, NoLock, Preserve)
{
    AccessAs(BufferAcc, SMBBlock)         // Use the SMBus Read/Write Block protocol
    FLD0, 8,                             // Virtual register at command value 0.

```

(continues on next page)

(continued from previous page)

```

    FLD1, 8, // Virtual register at command value 1.
    FLD2, 8 // Virtual register at command value 2.
}

// Create the SMBus data buffer
Name(BUFF, Buffer(34){}) // Create SMBus data buffer as BUFF
CreateByteField(BUFF, 0x00, STAT) // STAT = Status (Byte)
CreateByteField(BUFF, 0x01, SIZE) // SIZE = Length (Byte)
CreateField(BUFF, 0x10, 256, DATA) // DATA = Data (Block)

// Read block data from the device using command value 1
Store(FLD1, BUFF) // Invoke a Read Block transaction
If(LEqual(STAT, 0x00)) // Successful?
{
    // SIZE = Size (number of bytes)
    // of the block data read from FLD1...
    // DATA = Block data read from FLD1...
}

// Write the block 'TEST' to the device using command value 2
Store("TEST", DATA) // Save "TEST" into the data buffer
Store(4, SIZE) // Length of valid data in the data buffer
Store(BUFF, FLD2) // Invoke a Write Word transaction

```

In this example, three field elements (FLD0, FLD1, and FLD2) are defined to represent the virtual registers for command values 0, 1, and 2. Access to any of the field elements will cause an SMBus transaction to occur to the device. Reading FLD1 results in a Read Block with a command value of 1, and writing to FLD2 results in a Write Block with command value 2.

13.3.6 Word Process Call (SMBProcessCall)

The SMBus Process Call protocol (SMBProcessCall) transfers 2 bytes of data bi-directionally (performs a Write Word followed by a Read Word as an atomic transaction). This protocol uses a command value to reference up to 256 word-sized virtual registers.

The following ASL code illustrates how a device supporting the Process Call protocol should be accessed:

```

OperationRegion(SMBD, SMBus, 0x4200, 0x100) // SMBus device at slave address 0x42
Field(SMBD, BufferAcc, NoLock, Preserve)
{
    AccessAs(BufferAcc, SMBProcessCall) // Use the SMBus Process Call protocol
    FLD0, 8, // Virtual register at command value 0.
    FLD1, 8, // Virtual register at command value 1.
    FLD2, 8 // Virtual register at command value 2.
}

// Create the SMBus data buffer
Name(BUFF, Buffer(34){}) // Create SMBus data buffer as BUFF
CreateByteField(BUFF, 0x00, STAT) // STAT = Status (Byte)
CreateWordField(BUFF, 0x02, DATA) // DATA = Data (Word)

// Process Call with input value '0x5416' to the device using command value 1
Store(0x5416, DATA) // Save 0x5416 into the data buffer
Store(Store(BUFF, FLD1), BUFF) // Invoke a Process Call transaction
If(LEqual(STAT, 0x00)) // Successful?

```

(continues on next page)

(continued from previous page)

```
{
    // DATA = Word returned from FLD1...
}
```

In this example, three field elements (FLD0, FLD1, and FLD2) are defined to represent the virtual registers for command values 0, 1, and 2. Access to any of the field elements will cause an SMBus transaction to occur to the device. Reading or writing FLD1 results in a Process Call with a command value of 1. Notice that unlike other protocols, Process Call involves both a write and read operation in a single atomic transaction. This means that the Data element of the SMBus data buffer is set with an input value before the transaction is invoked, and holds the output value following the successful completion of the transaction.

13.3.7 Block Process Call (SMBBlockProcessCall)

The SMBus Block Write-Read Block Process Call protocol (SMBBlockProcessCall) transfers a block of data bidirectionally (performs a Write Block followed by a Read Block as an atomic transaction). The maximum aggregate amount of data that may be transferred is limited to 32 bytes. This protocol uses a command value to reference up to 256 block-sized virtual registers.

The following ASL code illustrates how a device supporting the Process Call protocol should be accessed:

```
OperationRegion(SMBD, SMBus, 0x4200, 0x100) // SMBus device at slave address 0x42
Field(SMBD, BufferAcc, NoLock, Preserve)
{
    AccessAs(BufferAcc, SMBBlockProcessCall) // Use the Block Process Call protocol
    FLD0, 8, // Virtual register representing a command value of 0
    FLD1, 8 // Virtual register representing a command value of 1
}

// Create the SMBus data buffer as BUFF
Name(BUFF, Buffer(34)()) // Create SMBus data buffer as BUFF
CreateByteField(BUFF, 0x00, STAT) // STAT = Status (Byte)
CreateByteField(BUFF, 0x01, SIZE) // SIZE = Length (Byte)
CreateField(BUFF, 0x10, 256, DATA) // Data (Block)

// Process Call with input value "ACPI" to the device using command value 1

Store("ACPI", DATA) // Fill in outgoing data
Store(8, SIZE) // Length of the valid data
Store(Store(BUFF, FLD1), BUFF) // Execute the PC
if (LEqual(STAT, 0x00)) // Test the status
{
    // BUFF now contains information returned
    // from PC
    // SIZE now equals size of data returned
}
```

PLATFORM COMMUNICATIONS CHANNEL (PCC)

The platform communication channel (PCC) is a generic mechanism for OSPM to communicate with an entity in the platform (e.g. a platform controller, or a Baseboard Management Controller (BMC)). Neither the entity that OSPM communicates with, nor any aspects of the information passed back and forth is defined in this section. That information is defined by the actual interface that that employs PCC register address space as the communication channel.

PCC defines a new address space type (PCC Space, 0xA), which is implemented as one or more independent communications channels, or subspaces.

This chapter is arranged as follows:

- The *Platform Communications Channel Table* and *Generic Communications Channel Shared Memory Region* provide reference information about the PCCT, and expected data structures used for the Platform Communications Channel.
- *Doorbell Protocol*, *Platform Notification*, and *Referencing the PCC address space* describe how communications takes place between the OSPM and the platform over PCC.

The PCC interface is described in the following ACPI system description table.

14.1 Platform Communications Channel Table

Table 14.1: Platform Communications Channel Table (PCCT)

Field	Byte Length	Byte Offset	Description
Header			
Signature	4	0	'PCCT' Signature for the Platform Communications Channel Table.
Length	4	4	Length, in bytes, of the entire PCCT.
Revision	1	8	2
Checksum	1	9	Entire table must sum to zero.
OEMID	6	10	OEM ID
OEM Table ID	8	16	For the PCCT, the table ID is the manufacturer model ID.
OEM Revision	4	24	OEM revision of PCCT for supplied OEM Table ID.
Creator ID	4	28	Vendor ID of utility that created the table. For tables containing Definition Blocks, this is the ID for the ASL Compiler.
Creator Revision	4	32	Revision of utility that created the table. For tables containing Definition Blocks, this is the revision for the ASL Compiler.

continues on next page

Table 14.1 – continued from previous page

Flags	4	36	Platform Communications Channel Global flags, described in <i>Platform Communications Channel Global Flags</i> .
<i>Reserved</i>	8	40	Reserved
PCC Subspace Structure[n] (n = subspace ID)	–	48	A list of Platform Communications Channel Subspace structures for this platform. This structure is described in the following section. At most 256 subspaces are supported.

14.1.1 Platform Communications Channel Global Flags

Table 14.2: Platform Communications Channel Global Flags

PCC Global Flags	Bit Length	Bit Offset	Description
Platform Interrupt	1	0	If set, the platform is capable of generating an interrupt to indicate completion of a command.
<i>Reserved</i>	31	1	Must be zero.

14.1.2 Platform Communications Channel Subspace Structures

PCC Subspaces are described by the PCC Subspace structure in the PCCT table. The subspace ID of a PCC subspace is its index in the array of subspace structures, starting with subspace 0. All subspaces have a common header, followed by a set of type-specific fields:

Table 14.3: Generic PCC Subspace Structure

Field	Byte Length	Byte Offset	Description
Type	1	0	The type of subspace.
Length	1	1	Length of the subspace structure, in bytes. The next subspace structure begins length bytes after the start of this one.
Type specific fields	variable	2	See specific subspace types for more details

This specification defines the following subspaces:

- Type 0, the Generic Communications Subspace,
- Types 1 to 2, HW-Reduced Communications Subspaces,
- Types 3 and 4 are extended PCC subspaces.
- Type 5 is the Hardware Register-Based PCC Subspace.

All other subspace types are reserved.

14.1.3 Generic Communications Subspace Structure (type 0)

Table 14.4: PCC Subspace Structure type 0 (Generic Communications Subspace)

Field	Byte Length	Byte Offset	Description
Type	1	0	0 (Generic Communications Subspace)
Length	1	1	62
<i>Reserved</i>	6	2	Reserved
Base Address	8	8	Base Address of the shared memory range, described in <i>Generic Communications Channel Shared Memory Region</i> .
Memory Length	8	16	Length of the memory range. Must be > 8.
Doorbell Register	12	24	Contains the processor relative address, represented in Generic Address Structure format, of the PCC doorbell. Note: Only System I/O space and System Memory space are valid for values for Address_Space_ID.
Doorbell Preserve	8	36	Contains a mask of bits to preserve when writing the doorbell register.
Doorbell Write	8	44	Contains a mask of bits to set when writing the doorbell register.
Nominal Latency	4	52	Expected latency to process a command, in microseconds.
Maximum Periodic Access Rate	4	56	The maximum number of periodic requests that the subspace channel can support, reported in commands per minute. 0 indicates no limitation.
Minimum Request Turnaround Time	2	60	The minimum amount of time that OSPM must wait after the completion of a command before issuing the next command, in microseconds.

Note: Inaccurate values for the Maximum Periodic Access Rate and Minimum Request Turnaround Time fields can result in punitive side effects for features that rely on the PCC interface. The Platform should report accurate values that allow for maximum channel efficiency while maintaining maximum channel stability.

The Maximum Periodic Access Rate is used by OSPM to determine the maximum rate for periodic evaluation of commands. Infrequent, event driven commands are not restricted by the maximum periodic access rate.

14.1.4 HW-Reduced Communications Subspace Structure (type 1)

The HW-Reduced Communications Subspace is defined in Table 14.5. It is intended for use on HW-Reduced ACPI Platforms, which do not support the SCI. Aside from the interrupt change, and the allowed use of the Functional Fixed HW address space for the Doorbell Register, this subspace is identical to the Generic Communications Subspace described in Section 14.2 and Section 14.5.

Table 14.5: PCC Subspace Structure type 1 (HW-Reduced Communications Subspace)

Field	Byte Length	Byte Offset	Description
-------	-------------	-------------	-------------

continues on next page

Table 14.5 – continued from previous page

Type	1	0	1 (HW-Reduced Communications Subspace)
Length	1	1	62
Platform Interrupt	4	2	GSIV of the interrupt used for the PCC platform interrupt for this Subspace.
Platform Interrupt Flags	1	6	Bit [2-7] Reserved Bit [1] Platform interrupt mode 1: Interrupt is Edge triggered 0: Interrupt is Level triggered Bit [0] Platform interrupt polarity 1: Interrupt is Active low 0: Interrupt is Active high
Reserved	1	7	Reserved
Base Address	8	8	Base Address of the shared memory range, described in <i>Generic Communications Channel Shared Memory Region</i> .
Memory Length	8	16	Length of the memory range. Must be > 8.
Doorbell Register	12	24	Contains the processor relative address, represented in Generic Address Structure format, of the PCC doorbell. Note: Only the System I/O, System Memory, and Functional Fixed Hardware spaces are valid for values for Address_Space_ID.
Doorbell Preserve	8	36	Contains a mask of bits to preserve when writing the doorbell register.
Doorbell Write	8	44	Contains a mask of bits to set when writing the doorbell register.
Nominal Latency	4	52	Expected latency to process a command, in microseconds.
Maximum Periodic Access Rate	4	56	The maximum number of periodic requests that the subspace channel can support, reported in commands per minute. 0 indicates no limitation.
Minimum Request Turnaround Time	2	60	The minimum amount of time that OSPM must wait after the completion of a command before issuing the next command, in microseconds.

Note: Inaccurate values for the Maximum Periodic Access Rate and Minimum Request Turnaround Time fields can result in punitive side effects for features that rely on the PCC interface. The Platform should report accurate values that allow for maximum channel efficiency while maintaining maximum channel stability.

The Maximum Periodic Access Rate is used by OSPM to determine the maximum rate for periodic evaluation of commands. Infrequent, event driven commands are not restricted by the maximum periodic access rate.

Type 1 subspaces do not support a level triggered platform interrupt as no method is provided to clear the interrupt. Where level interrupts are required, type 2 or type 3 subspaces should be used.

14.1.5 HW-Reduced Communications Subspace Structure (type 2)

The HW-Reduced Communications Subspace is defined below in Table 14.6. This is intended for use on HW-Reduced ACPI Platforms, which require read-modify-write sequence to acknowledge Platform Interrupt. Aside from three Platform Ack fields at the bottom of the table, this subspace is identical to *HW-Reduced Communications Subspace Structure (type 1)* described above.

Table 14.6: PCC Subspace Structure type 2 (HW-Reduced Communications Subspace)

Field	Byte Length	Byte Offset	Description
Type	1	0	2 (HW-Reduced Communications Subspace)
Length	1	1	90
Platform Interrupt	4	2	GSIV of the interrupt used for the PCC platform interrupt for this Subspace.
Platform Interrupt Flags	1	6	Bit [2-7] Reserved Bit [1] Platform interrupt mode 1: Interrupt is Edge triggered 0: Interrupt is Level triggered Bit [0] Platform interrupt polarity 1: Interrupt is Active low 0: Interrupt is Active high
Reserved	1	7	Reserved
Base Address	8	8	Base Address of the shared memory range, described in <i>Generic Communications Channel Shared Memory Region</i> .
Memory Length	8	16	Length of the memory range. Must be > 8.
Doorbell Register	12	24	Contains the processor relative address, represented in Generic Address Structure format, of the PCC doorbell. Note: Only the System I/O, System Memory, and Functional Fixed Hardware spaces are valid for values for Address_Space_ID.
Doorbell Preserve	8	36	Contains a mask of bits to preserve when writing the doorbell register.
Doorbell Write	8	44	Contains a mask of bits to set when writing the doorbell register.
Nominal Latency	4	52	Expected latency to process a command, in microseconds.
Maximum Periodic Access Rate	4	56	The maximum number of periodic requests that the subspace channel can support, reported in commands per minute. 0 indicates no limitation.
Minimum Request Turnaround Time	2	60	The minimum amount of time that OSPM must wait after the completion of a command before issuing the next command, in microseconds.
Platform Interrupt Ack Register	12	62	Contains the processor relative address, represented in Generic Address Structure format, of the platform interrupt ack register. Note: Only the System I/O, System Memory, and Functional Fixed Hardware spaces are valid for values for Address_Space_ID.
Platform Interrupt Ack Preserve	8	74	Contains a mask of bits to preserve when writing the platform interrupt ack register.

continues on next page

Table 14.6 – continued from previous page

Platform In- errupt Ack Write	8	82	Contains a mask of bits to set when writing the platform interrupt ack register.
-------------------------------------	---	----	--

Note: Inaccurate values for the Maximum Periodic Access Rate and Minimum Request Turnaround Time fields can result in punitive side effects for features that rely on the PCC interface. The Platform should report accurate values that allow for maximum channel efficiency while maintaining maximum channel stability.

The Maximum Periodic Access Rate is used by OSPM to determine the maximum rate for periodic evaluation of commands. Infrequent, event driven commands are not restricted by the maximum periodic access rate.

14.1.6 Extended PCC subspaces (types 3 and 4)

Extended PCC communication subspaces are of two types:

Type 3 Initiator subspace: used by the OSPM to communicate with the platform.

Type 4 Responder subspace: Used by the platform to send asynchronous notifications to the OSPM.

Initiator subspaces are not substantially different to type 0,1, or 2 subspaces, the most notable difference is that a type 3 Initiator subspace does not support asynchronous notifications. Responder subspaces, type 4, provide those notifications, and cannot be used by the OSPM to send messages to the platform. Together an Initiator and Responder pair create a bidirectional interface between the OSPM and the platform.

The format for PCCT entries describing Initiator (type 3), and Responder (type 4) subspaces is shown in the following table.

Table 14.7: PCC Subspace Structure type 3 and type 4

Field	Byte Length	Byte Offset	Description
Type	1	0	3 - Initiator subspace 4 - Responder subspace
Length	1	1	164
Platform Interrupt	4	2	GSIV of an interrupt triggered by the platform: For Initiator subspaces (type 3) this is raised when a command is completed on this subspace. For Responder subspaces (type 4) this is raised when platform sends a notification. For a Initiator subspace, this field is ignored if the platform interrupt flag in Table 14.2 is set to zero. If a Responder-subspace is present in the PCCT, then the platform interrupt flag must be set to 1. Note that if interrupts are edge triggered, then each subspace must have its own unique interrupt. If interrupts are level, a GSIV may be shared by multiple subspaces, but each one must have unique Platform interrupt Ack preserve and Ack Set masks.
Platform Interrupt Flags	1	6	Bit 7:2 Reserved Bit 1: Platform interrupt mode - Set to 1 if interrupt is Edge triggered - Set to 0 if interrupt Level triggered Bit 0: Platform interrupt polarity - Set to 1 if interrupt is Active low - Set to 0 if interrupt is Active high
Reserved	1	7	Reserved must be zero

continues on next page

Table 14.7 – continued from previous page

Base Address	8	8	Base Address of the shared memory range, described in the <i>Initiator Responder Communications Channel Shared Memory Region</i> .
Memory Length	4	16	Length of the memory range. Must be ≥ 16 .
Doorbell Register	12	20	Contains the processor relative address, represented in Generic Address Structure (GAS) format, of the PCC doorbell. Note: Only the System I/O, System Memory, and Functional Fixed Hardware spaces are valid values for Address_Space_ID For Responder subspaces this field is optional, if not present the field should just contain zeros.
Doorbell Preserve	8	32	Contains a mask of bits to preserve when writing the doorbell register.
Doorbell Write	8	40	Contains a mask of bits to set when writing the doorbell register.
Nominal Latency	4	48	Expected latency to process a command, in microseconds. This field is only relevant for Initiator subspaces.
Maximum Periodic Access Rate	4	52	The maximum number of periodic requests that the subspace subspace can support, reported in commands per minute. 0 indicates no limitation. This field is only relevant for Initiator subspaces.
Minimum Request Turnaround Time	4	56	The minimum amount of time that OSPM must wait after the completion of a command before issuing the next command, in microseconds. This field is only relevant for Initiator subspaces.
Platform interrupt Ack Register	12	60	Contains the processor relative address, represented in Generic Address Structure (GAS) format, of the platform interrupt acknowledge register. Note: Only the System I/O, System Memory, and Functional Fixed Hardware spaces are valid for values for Address_Space_ID. If the subspace does not support interrupts or the interrupt is edge driven the register may be omitted. A value of 0x0 on all 12 bytes of the GAS structure indicates the register is not present. If the subspace does support interrupts, and these are level, this register must be supplied. And is used to clear the interrupt by using a read, modify, write sequence.
Platform interrupt Ack Preserve	8	72	Contains a mask of bits to preserve when writing the platform interrupt ack register.
Platform interrupt Ack Set	8	80	Contains a mask of bits to set when writing the platform interrupt ack register.
Reserved	8	88	Reserved must be zero
Command complete check register address	12	96	Contains the processor relative address, represented in Generic Address Structure (GAS) format, of the Command complete check register. Note: Only the System I/O, System Memory, and Functional Fixed Hardware spaces are valid for values for Address_Space_ID
Command complete check mask	8	108	Mask to determine whether a command is complete, using the command complete check register. A command is complete if the value of the register when combined through a logical AND with this mask, yields a non-zero value
Command complete update register address	12	116	Contains the processor relative address, represented in Generic Address Structure (GAS) format, of the command complete update register. Note: Only the System I/O, System Memory, and Functional Fixed Hardware spaces are valid for values for Address_Space_ID

continues on next page

Table 14.7 – continued from previous page

Command complete update preserve mask	8	128	Mask of bits to preserve in the command complete update register, when updating command complete in this subspace.
Command complete update set mask	8	136	Mask of bits to set in the command complete update register, when updating command complete in this subspace. For Initiator subspaces the mask must indicate how to clear the command complete bit. For Responder subspaces, the mask must indicate how to set the command complete bit.
Error status register	12	144	Contains the processor relative address, represented in Generic Address Structure (GAS) format, of the Error status register. This field is ignored by the OSPM on Responder channels Note: Only the System I/O, System Memory, and Functional Fixed Hardware spaces are valid for values for Address_Space_ID Note: this register can be the same as the command complete check register.
Error status mask	8	156	The mask contained here can be combined through a logical AND with content of the Error status register to ascertain whether an error occurred in the transmission of the command through the subspace. The logical NOT of this mask is be used to clear the error. The inverted mask is combined through a logical AND with the content of the Error status register, and the result is written back into said register. This field is ignored for Responder channels.

Note: Inaccurate values for the Maximum Periodic Access Rate and Minimum Request Turnaround Time fields can result in punitive side effects for features that rely on the PCC interface. The Platform should report accurate values that allow for maximum channel efficiency while maintaining maximum channel stability.

Responder subspaces may be used by the platform to send asynchronous notifications to the OSPM. Responder subspace entries in the PCCT share the same format as Initiator subspaces, with the following modifications:

- Type is set to 4 - Responder subspace
- The doorbell may be zero and if so must be ignored by the OSM. If present, the platform can request that the OSPM writes to the doorbell after it has processed a notification.

A Responder subspace is associated with an Initiator, that is both an Initiator/Responder pair will connect the OSPM to the same processing entity in the platform.

If a Responder subspace is included in the PCCT, then the global Platform Interrupt flag (see Table 14.2) must be set to 1.

14.1.7 HW Registers based Communications Subspace Structure (Type 5)

Table 14.8: HW Registers based Communications Subspace Structure (Type 5)

Field	Length (in bytes)	Offset	Value
Type	1	0	5
Length	1	1	Length (includes vendor defined area)
Version	2	2	0x0001 (Version 1 of this PCC definition)

continues on next page

Table 14.8 – continued from previous page

Base Address	8	4	Base Address of the shared memory range, described in Section 14.4
Shared Memory Range Length	8	12	Length of the shared memory range described in Table 14.14 . If this length is zero then based address is ignored.
Doorbell Register	12	20	Contains the processor relative address, represented in Generic Address Structure format, of the PCC doorbell. Note: Only System I/O space and System Memory space are valid for values for Address_Space_ID.
Doorbell Preserve	8	32	Contains a mask of bits to preserve when writing the doorbell register
Doorbell Write	8	40	Contains a mask of bits to set when writing the doorbell register. This is used to send specific commands to the Platform.
Command Complete Check Register	12	48	Contains the processor relative address, represented in Generic Address Structure format, of Command complete Check register. Note: Only System I/O space and System Memory space are valid for values for Address_Space_ID.
Command Complete Check mask	8	60	Contains a mask of bits to query completion status of the previously issued command from the Command Complete Status Register. OS shall do an AND operation with the Command Complete Check Register value. The OS must check the completion status before writing to doorbell register for the next command. If calculated value is 0 then previous operation has been completed. If completion status is not implemented then this mask should be 0. In this case OS shall only wait for Minimum Request Turnaround Time. Note: Command complete check needs be done before writing to doorbell register to avoid any race condition with a previous use of the doorbell register. In addition to that command complete check needs to be done after writing to doorbell register and before reading Status from Error Status Register.
Error Status Register	12	68	Contains the processor relative address, represented in Generic Address Structure format, of Error Status register. Note: Only System I/O space and System Memory space are valid for values for Address_Space_ID.
Error Status mask	8	80	Contains a mask of bits to get error status of the previous command request from Error Status Register. OS shall do an AND operation with Error Status register value. If this mask value is 0 then Error Status register is ignored. Error Status needs to be checked after completion status indicates issued command has been completed. If Command Complete Check is not implemented (means Command Complete Check mask is 0) then wait for Minimum Request Turnaround Time. If the calculated value is zero, then it indicates success. Any other value indicates failure.
Nominal Latency	4	88	Expected latency to process a command, in microseconds.
Minimum Request Turnaround Time	4	92	The minimum amount of time that OSPM must wait after the completion of a command before issuing the next command, in microseconds.

14.2 Generic Communications Channel Shared Memory Region

Table 14.9: Generic Communications Channel Shared Memory Region

Field	Byte Length	Byte Offset	Description
Signature	4	0	The PCC signature. The signature of a subspace is computed by a bitwise-or of the value 0x50434300 with the subspace ID. For example, subspace 3 has the signature 0x50434303.
Command	2	4	PCC command field, described in the <i>Generic Communications Channel Command Field</i> .
Status	2	6	PCC status field, described in the <i>Generic Communications Channel Status Field</i> .
Communication Space	–	8	Memory region for reading/writing PCC data. The size of this region is 8 bytes smaller than the size of the shared memory region (specified in the General Communications Subspace structure). The first byte of this field represents PCC address 0.

14.2.1 Generic Communications Channel Command Field

For channels of type 0 to 2, this 16-bit field is used to select one of the defined commands for the platform to perform. OSPM is responsible for populating this field before each command invocation.

Table 14.10: Generic Communications Channel Command Field

Field	Bit Length	Bit Offset	Description
Command	8	0	Command code to execute. Command codes are application specific and defined by the consumer of this interface.
<i>Reserved</i>	7	8	Reserved.
Notify on completion	1	15	If set, the platform should generate a Doorbell interrupt at the completion of this command. The interrupt is an SCI for a Type 0 subspace structure, or as described by the Doorbell Interrupt field for Type 1 and Type 2 subspace structures. If the Doorbell bit is not set in the PCC global flags, this bit must be cleared.

14.2.2 Generic Communications Channel Status Field

Table 14.11: Generic Communications Channel Status Field

Field	Bit Length	Bit Offset	Description
Command Complete	1	0	If set, the platform has completed processing the last command.
Platform interrupt	1	1	If set, the platform has issued a Platform Interrupt to this subspace. OSPM must check the Command Complete and Platform Notification fields to determine the cause of the Interrupt.
Error	1	2	If set, an error occurred executing the last command.

continues on next page

Table 14.11 – continued from previous page

Platform Notifica- tion	1	3	If set, indicates the platform is issuing an asynchronous notification to OSPM.
<i>Reserved</i>	12	4	Reserved.

Note: OSPM (either in an Interrupt handler or via polling) is required to detect that the Command Complete bit has been set and to clear it before issuing another command. While waiting for this bit to be set, OSPM must not modify any portion of the shared memory region.

Note: The Platform Interrupt bit is required to be cleared in OSPM’s Interrupt handler so that a new event can be detected.

14.3 Extended PCC Subspace Shared Memory Region

Table 14.12: Initiator Responder Communications Channel Shared Memory Region

Field	Byte Length	Byte Offset	Description
Signature	4	0	The PCC signature. The signature of a subspace is computed by a bitwise-or of the value 0x50434300 with the subspace ID. For example, subspace 3 has the signature 0x50434303.
Flags	4	4	See <i>Initiator Responder Communications Channel Flags</i> below.
Length	4	8	Length of payload being transmitted including command field.
Command	4	12	Command being sent over the subspace.
Communication subspace	–	16	Memory region for reading/writing PCC data. The maximum size of this region is 16 bytes smaller than the size of the shared memory region (specified in the Initiator Responder Communications Subspace structure). When a command is sent to or received from the platform, the size of the data in this space will be Length (expressed above) minus the 4 bytes taken up by the command.

The 32-bit command field is used to select one of the defined commands for the platform to perform. On Initiator subspaces the OSPM is responsible for populating this field, alongside the command’s payload, length and flags. For Responder subspaces, the OSPM is responsible for interpreting the command and payload fields to ascertain the nature of the notification that was sent. The format for the flags field is shown in the table below.

Table 14.13: Initiator Responder Communications Channel Flags

Field	Bit Length	Bit Off-set	Description
-------	------------	-------------	-------------

continues on next page

Table 14.13 – continued from previous page

Notify on completion	1	0	For Initiator subspaces this field indicates to the platform that it must generate an interrupt when the command has completed. - Setting this bit to 1 when sending a command, requests that completion of the command is signaled via the platform interrupt. - Setting it to 0 when sending a command, requests that no interrupt is asserted when the command is completed. For Responder subspaces, if the doorbell field of the Responder subspace is non zero, and this flag is set, the OSPM must access the doorbell once it has processed the notification. This bit is ignored by the platform if the Platform Interrupt field of the PCC flags (<i>Platform Communications Channel Global Flags</i>) is set to zero.
Reserved	31	1	

14.4 Reduced PCC Subspace Shared Memory Region

Table 14.14: Reduced PCC Subspace Shared Memory Region

Field	Byte Length	Byte Offset	Description
Signature	4	0	The PCC signature. The signature of a subspace is computed by a bitwise-or of the value 0x50434300 with the subspace ID. For example, subspace 3 has the signature 0x50434303.
Communication Subspace	–	4	Memory region for reading/writing PCC data. The maximum size of this region is 4 bytes smaller than the size of the shared memory region (specified in the Type 5 PCC Subspace structure). When a command is sent to or received from the platform, the size of the data in this space will be Length (expressed above) minus the 4 bytes taken up by the Signature.

14.5 Doorbell Protocol

Other than on Responder subspaces, the doorbell is used by OSPM to notify the platform that the shared memory region contains a valid command that is ready to be processed. A doorbell consists of a hardware register that is accessed via I/O or memory mapped I/O, abstracted in the doorbell field of the PCC subspace structure. OSPM rings the doorbell by performing a read/modify/write cycle on the specified register, preserving and setting the bits specified in the preserve and write mask of the PCC subspace structure.

The figure above illustrates the steps that the OSPM takes to send message to the platform over a PCC subspace.

1. First the OSPM checks that there is no command pending completion on the subspace, indicating that the subspace is free for use. This is done by checking that the command complete bit is set in the status field of the subspace. If the bit is set the subspace is free for use, and the shared memory associated with the subspace is exclusively owned by the OSPM.
2. The OSPM places a command into the shared memory of the subspace to update the flags, length, command and payload fields (See *Generic Communications Channel Shared Memory Region*). If the platform indicates support for platform interrupts in the PCCT (See *Platform Communications Channel Global Flags*), then the OSPM can request that the platform generate an interrupt once it has completed processing the command. This is requested by setting the Notify on completion bit in the flags (See *Platform Communications Channel Global Flags* and *Initiator Responder Communications Channel Flags*).

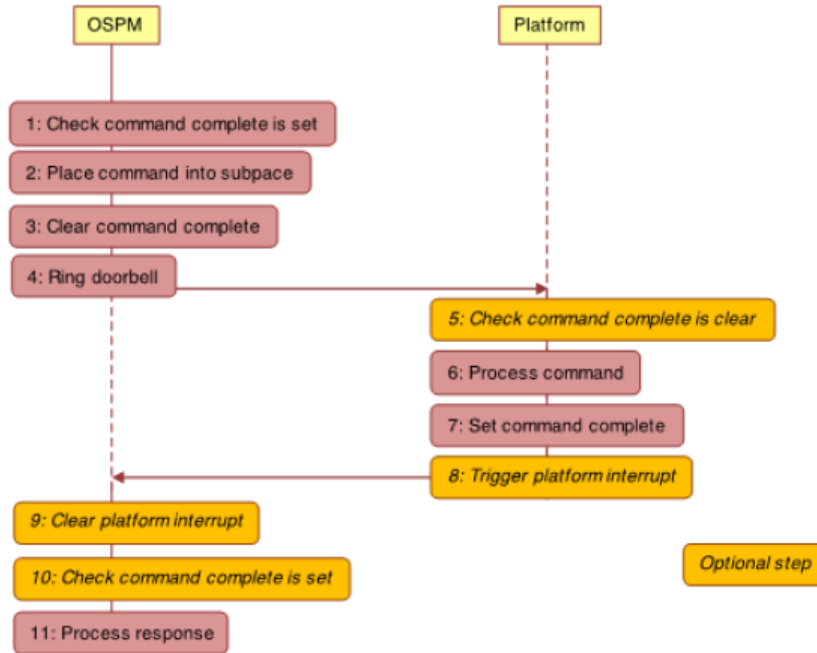

Fig. 14.1: Communication flow of the doorbell protocol

3. The OSPM then clears the command complete bit. This step transfers ownership of the shared memory to the platform.
4. OSPM rings the doorbell by performing a read/modify/write cycle on the specified register, preserving and setting the bits specified in the preserve and write mask of the PCC subspace structure.

The management of the command complete bit differs slightly between subspaces of types 0-2 and those of type 3. For the former, the command complete bit is in a status register which follows a specific format described in *Generic Communications Channel Status Field*. Type 3 subspaces still use a single command complete bit, however allow the platform to dictate the location and format of the register holding it. Therefore, PCCT structures describing type 3 subspaces use masks and an address to describe how to set the bit. Equally, masks are used for describing how to clear the bit. For these subspaces to check if the command complete bit is set, the OSPM combines the content of command complete check register, through a bitwise AND, with the command complete check mask. A non-zero value indicates the command complete bit is set.

Clearing the command complete bit is done through the command complete update register, which can differ in address from the command complete check register. In this case the content of the update register is combined through a bitwise AND with the preserve mask, the result is then combined through a bitwise inclusive OR with the set mask, and that result is written back to the update register.

For subspaces of type 1-3, the command complete bit must be initialized to one, command complete set, prior to OSPM sending a command. On type 0 channels, whether the platform sets command complete when the subspace is initialized is implementation defined. On these subspaces, the OSPM does not have to check for command complete to be set before sending the first command.

The figure *Communication flow of the doorbell protocol* above illustrates the steps the platform takes when it receives the command:

5. For robustness the platform might optionally check that command complete bit is clear
6. Processes the command
7. Sets the command complete bit

8. Triggers the platform interrupt indicated by the GSIV of the subspace's PCCT entry (see [Table 14.7](#)). This will only occur if an interrupt has been requested in step 2, and interrupts are supported by the platform. A platform can indicate support for interrupts through the Platform interrupt flag (See [Table 14.2](#))

OSPM can detect command completion either by polling on the command complete bit or via a platform interrupts. When the OSPM detects that the command has completed it proceeds with the following steps:

9. If necessary clears platform interrupt. This step applies if:
 - Platform interrupts are supported by the platform on command completion (see [Table 14.2](#)).
 - The interrupt was requested by the OSPM through the Notify on completion flag (see [Table 14.9](#) and *Initiator Responder Communications Channel Flags*).
 - The interrupt is described as being a level triggered through the Platform Interrupt flags, and Platform Interrupt Ack register address, and associated masks are provided by the subspace PCCT entry (see table entries for types 2 and 3).
10. If detecting command completion via interrupt, optionally checks command is complete.
11. Processes the command response.

To ensure correct operation, it is necessary to ensure that all memory updates performed by the OSPM in step 2 are observable by the platform before step 3 completes. Equally all memory updates performed by the platform in step 6 must be observable by the OSPM before step 7 completes.

Note: For subspace types 0 to 2, all accesses to the Status Field must be made using interlocked operations, by both entities sharing the subspace. Types 3-4 avoid this requirement. This requirement will be removed for subspace types 0 to 2 as part of deprecation of platform async notifications in a future spec revision (See the *Platform Notification* section below).

14.6 Platform Notification

The following sections describe platform notifications on subspace types 0-2 and types 3-4.

14.6.1 Platform Notification for Subspace Types 0, 1 and 2

The doorbell protocol is a synchronous notification from OSPM to the platform to process a command. If the platform wants to notify OSPM of an event asynchronously, it may set the Platform Interrupt and Platform Notification status bits and issue a Platform Interrupt. OSPM will service the Interrupt, clear the Platform Interrupt and Platform Notification bits, and service the platform notification. The meaning of the platform notification and the steps required to service it are defined by the individual components utilizing the PCC interface.

The platform must wait until OSPM has issued a consumer defined command that serves to notify the platform that OSPM is ready to service Platform Notifications. The command is subspace specific and may not be supported by all subspaces. Platform Notifications must be used in conjunction with an interrupt. Polling for Platform Notifications is not supported.

The platform may not modify any portion of the shared memory region other than the status field when issuing a platform notification.

Platform notifications for subspace types 0, 1, and 2 will be deprecated in a future revision of the specification. Implementers requiring the platform be able to send asynchronous notifications to OSPM should use Initiator/Responder subspaces.

Note: All accesses to the Status Field must be made using interlocked operations, by both entities sharing the subspace. This requirement will be removed for subspace types 0 to 2 as part of deprecation of platform async notifications in a future spec revision.

14.6.2 Platform Notification for Responder PCC subspaces (type 4)

Initiator and subspaces only allow synchronous communication from the OSPM to the platform, and do not use the platform notification mechanism provided for subspaces of types 0 to 2. Instead a Initiator subspace can be paired with a Responder subspace, type 4, which is specifically provided for platform to OSPM communications.

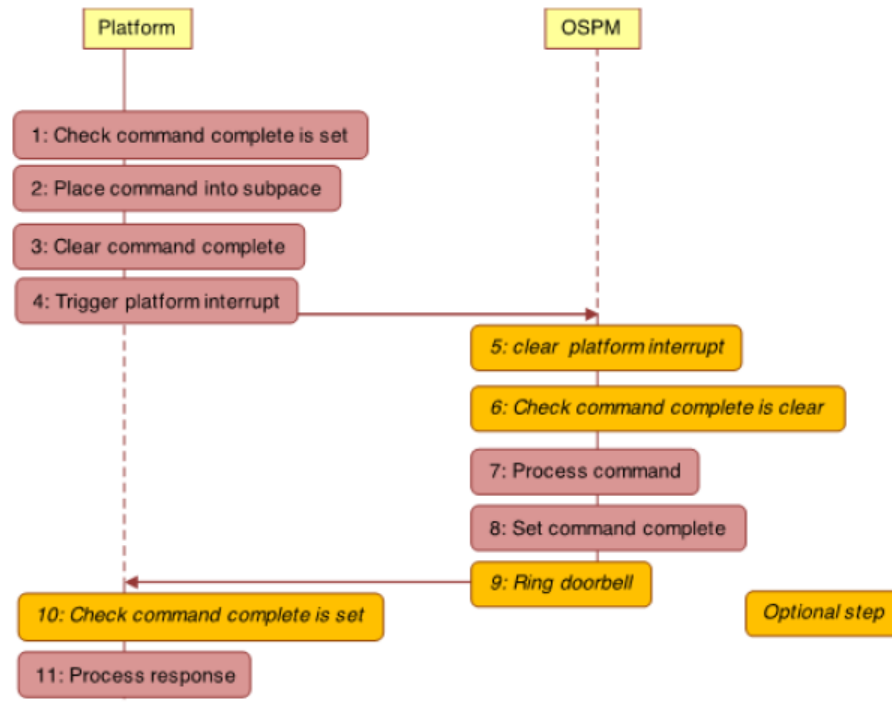

Fig. 14.2: Communication flow for notifications on Responder subspaces

Like type 3 Initiator subspaces, type 4 Responder subspaces include a command complete bit. Responder subspaces are owned by the OSPM by default, and therefore it must set the set the command complete bit when it is ready to receive notifications from the platform.

The flow of communications for a notification is illustrated in the figure *Communication flow for notifications on Responder subspaces* above. As can be seen the communication flow is very similar to that of an Initiator subspace, shown in the figure *Communication flow of the doorbell protocol* above, except that the roles of the platform and the OSPM are reversed. The steps are as follows:

1. First, the platform checks that there no command pending completion on the subspace, indicating that the subspace is free for use. This is done by checking that the command complete bit is set in the status field of the subspace. If the bit is set the subspace is free for use, and the shared memory associated with the subspace is exclusively owned by the platform.
2. The platform places a notification command into the shared memory in the subspace, updating the flags, length, command and payload fields (See *Initiator Responder Communications Channel Shared Memory Region*) The platform can request the OSPM rings the doorbell once it has completed processing the notification command by setting the Generate Signal bit in the flags (see Table 14.13).

3. The platform then clears the command complete bit. This transfers ownership of the shared memory to the OSPM.
4. The platform raises the platform interrupt indicated by the GSIV of the Responder subspace.

When the OSPM receives the interrupt it executes the following steps:

5. Clears the platform interrupt. This is required if the interrupt is described as being a level triggered through the Platform Interrupt flags, and Platform Interrupt Ack register address, and associated masks are provided by the subspace PCCT entry (see Table 14.7).
6. Optionally checks the command complete bit is clear.
7. Processes the notification command.
8. Sets the command complete bit using the command complete update register and masks.
9. Rings the doorbell. This is required if the doorbell ring was requested by the platform in step 2 above. This also requires that the PCCT entry for the subspace has a non-zero doorbell register address.

The platform can check whether a notification has been processed by the OSPM either by polling the command complete bit, or where supported through receiving a doorbell interrupt from the OSPM. When the platform detects that the notification has been processed by the OSPM, the platform takes the following steps:

10. If polling check command complete is set. If using a doorbell this step is optional.
11. Processes the command response

The platform must ensure that any writes in step 2, are observable by the OSPM application processors before writes in step 3. Similarly, the OSPM must ensure that any writes in step 7 are observable by the platform before step 8 completes.

Individual protocols that use PCC define the meaning of notifications.

14.7 Referencing the PCC address space

An individual PCC register may be referenced by the Generic Address Structure or in a Generic Register Descriptor by using the Address Space ID PCC (0xA). When using the PCC address space, the Access Size field is redefined to Subspace ID, and identifies which PCC subspace the descriptor refers to.

As an example, the following resource template refers to the field occupying bits 8 through 15 at address 0x30 in PCC subspace 9:

```
ResourceTemplate()
{
    Register (
        PCC,           //AddressSpaceKeyword
        8,             //RegisterBitWidth
        8,             //RegisterBitOffset
        0x30,          //RegisterAddress
        9              //AccessSize (subspace ID)
    )
}
```

Note that the PCC address space may not be used in any resource template or register unless the register/resource field explicitly allows the use of the PCC address space.

SYSTEM ADDRESS MAP INTERFACES

This section explains how an ACPI-compatible system conveys its memory resources/type mappings to OSPM. There are three ways for the system to convey memory resources /mappings to OSPM. The first is an INT 15 BIOS interface that is used in IA-PC-based systems to convey the system's initial memory map. UEFI enabled systems use the UEFI GetMemoryMap() boot services function to convey memory resources to the OS loader. These resources must then be conveyed by the OS loader to OSPM. See the UEFI Specification for more information on UEFI services.

Lastly, if memory resources may be added or removed dynamically, memory devices are defined in the ACPI Namespace conveying the resource information described by the memory device (see *Memory Devices*).

ACPI defines the following address range types.

Table 15.1: Address Range Types

Value	Mnemonic	Save in S4	Description
1	AddressRangeMemory	Yes	This range is available RAM usable by the operating system.
2	AddressRangeReserved	No	This range of addresses is in use or reserved by the system and is not to be included in the allocatable memory pool of the operating system's memory manager.
3	AddressRangeACPI	Yes	ACPI Reclaim Memory. This range is available RAM usable by the OS after it reads the ACPI tables.
4	AddressRangeNVS	Yes	ACPI NVS Memory. This range of addresses is in use or reserved by the system and must not be used by the operating system. This range is required to be saved and restored across an NVS sleep.
5	AddressRangeUnusable	No	This range of addresses contains memory in which errors have been detected. This range must not be used by OSPM.
6	AddressRangeDisabled	No	This range of addresses contains memory that is not enabled. This range must not be used by OSPM.

continues on next page

Table 15.1 – continued from previous page

Value	Mnemonic	Save in S4	Description
7	AddressRangePersistentMemory	No	OSPM must comprehend this memory as having non-volatile attributes and handle distinct from conventional volatile memory. The memory region supports byte-addressable non-volatility. NOTE: Extended Attributes for the memory reported using AddressRangePersistentMemory should set Bit [0] to 1 (see <i>Extended Attributes for Address Range Descriptor Structure</i>).
8	AddressRangeUnaccepted	No	A memory region that represents unaccepted memory, that must be accepted by the boot target before it can be used. Unless otherwise noted, all other memory types are accepted. For platforms that support unaccepted memory, all unaccepted valid memory will be reported as unaccepted in the memory map. Unreported physical address ranges must be treated as not-present memory.
9-11	Undefined	No	Reserved for future use. OSPM must treat any range of this type as if the type returned was <i>AddressRangeReserved</i> .
12	OEM defined	No	An OS should not use a memory type in the vendor-defined range because collisions may occur between different vendors.
13 to 0xEFFFFFFF	Undefined	No	Reserved for future use. OSPM must treat any range of this type as if the type returned was <i>AddressRangeReserved</i> .
0xF0000000 to 0xFFFFFFFF	OEM defined	No	An OS should not use a memory type in the vendor-defined range because collisions may occur between different vendors.

Platform runtime firmware can use the AddressRangeReserved address range type to block out various addresses as not suitable for use by a programmable device. Some of the reasons a platform runtime firmware would do this are:

- The address range contains system ROM.
- The address range contains RAM in use by the ROM.
- The address range is in use by a memory-mapped system device.
- The address range is, for whatever reason, unsuitable for a standard device to use as a device memory space.
- The address range is within an NVRAM device where reads and writes to memory locations are no longer successful, that is, the device was worn out.
- OSPM will not save or restore memory reported as AddressRangeReserved, AddressRangeUnusable, AddressRangeDisabled, or AddressRangePersistentMemory when transitioning to or from the S4 sleeping state.
- Platform boot firmware must ensure that contents of memory that is reported as AddressRangePersistentMemory is retained after a system reset or a power cycle event.

15.1 INT 15H, E820H - Query System Address Map

This interface is used in real mode only on IA-PC-based systems and provides a memory map for all of the installed RAM, and of physical memory ranges reserved by the BIOS. The address map is returned through successive invocations of this interface; each returning information on a single range of physical addresses. Each range includes a type that indicates how the range of physical addresses is to be treated by the OSPM.

If the information returned from E820 in some way differs from INT-15 88 or INT-15 E801, the information returned from E820 supersedes the information returned from INT-15 88 or INT-15 E801. This replacement allows the BIOS to return any information that it requires from INT-15 88 or INT-15 E801 for compatibility reasons. For compatibility reasons, if E820 returns any AddressRangeACPI or AddressRangeNVS memory ranges below 16 MiB, the INT-15 88 and INT-15 E801 functions must return the top of memory below the AddressRangeACPI and AddressRangeNVS memory ranges.

The memory map conveyed by this interface is not required to reflect any changes in available physical memory that have occurred after the BIOS has initially passed control to the operating system. For example, if memory is added dynamically, this interface is not required to reflect the new system memory configuration.

Table 15.2: Input to the INT 15h E820h Call

Register	Contents	Description
EAX	Function Code	E820h
EBX	Continuation	Contains the continuation value to get the next range of physical memory. This is the value returned by a previous call to this routine. If this is the first call, EBX must contain zero.
ES:DI	Buffer Pointer	Pointer to an Address Range Descriptor structure that the BIOS fills in.
ECX	Buffer Size	The length in bytes of the structure passed to the BIOS. The BIOS fills in the number of bytes of the structure indicated in the ECX register, maximum, or whatever amount of the structure the BIOS implements. The minimum size that must be supported by both the BIOS and the caller is 20 bytes. Future implementations might extend this structure.
EDX	Signature	'SMAP' Used by the BIOS to verify the caller is requesting the system map information to be returned in ES:DI.

Table 15.3: Output from the INT 15h E820h Call

Register	Contents	Description
CF	Carry Flag	Non-Carry - Indicates No Error
EAX	Signature	'SMAP' Signature to verify correct BIOS revision.
ES:DI	Buffer Pointer	Returned Address Range Descriptor pointer. Same value as on input.
ECX	Buffer Size	Number of bytes returned by the BIOS in the address range descriptor. The minimum size structure returned by the BIOS is 20 bytes.
EBX	Continuation	Contains the continuation value to get the next address range descriptor. The actual significance of the continuation value is up to the discretion of the BIOS. The caller must pass the continuation value unchanged as input to the next iteration of the E820 call in order to get the next Address Range Descriptor. A return value of zero means that this is the last descriptor. Note: the BIOS can also indicate that the last descriptor has already been returned during previous iterations by returning the carry flag set. The caller will ignore any other information returned by the BIOS when the carry flag is set.

Table 15.4: Address Range Descriptor Structure

Offset in Bytes	Name	Description
0	BaseAddrLow	Low 32 Bits of Base Address
4	BaseAddrHigh	High 32 Bits of Base Address
8	LengthLow	Low 32 Bits of Length in Bytes
12	LengthHigh	High 32 Bits of Length in Bytes
16	Type	Address type of this range
20	Extended Attributes	See the <i>Extended Attributes for Address Range Descriptor Structure</i>

The BaseAddrLow and BaseAddrHigh together are the 64-bit base address of this range. The base address is the physical address of the start of the range being specified.

The LengthLow and LengthHigh together are the 64-bit length of this range. The length is the physical contiguous length in bytes of a range being specified.

The Type field describes the usage of the described address range as defined in *Address Range Types*.

Table 15.5: Extended Attributes for Address Range Descriptor Structure

Bit	Mnemonic	Description
0	<i>Reserved</i>	Reserved, must be set to 1.
2:1	Reserved	Reserved, must be set to 0.
3	AddressRangeErrorLog	If set, the address range descriptor represents memory used for logging hardware errors.
31:4	<i>Reserved</i>	Reserved for future use.

Note: Bit [1] and [2] above were deprecated as of ACPI 6.1. Bit [3] is used only on PC-AT BIOS systems to pinpoint the error log in memory. On UEFI-based systems, either UEFI Hardware Error Record HwErrRec#### runtime UEFI variable interface or the Error Record Serialization Actions 0xD, 0xE and 0xF for the APEI ERST interface must be implemented for the error logs.

15.2 E820 Assumptions and Limitations

- The platform boot firmware returns address ranges describing baseboard memory.
- The platform boot firmware does not return a range description for the memory mapping of PCI devices, ISA Option ROMs, and ISA Plug and Play cards because the OS has mechanisms available to detect them.
- The platform boot firmware returns chip set-defined address holes that are not being used by devices as reserved.
- Address ranges defined for baseboard memory-mapped I/O devices, such as APICs, are returned as reserved.
- All occurrences of the system platform boot firmware are mapped as reserved, including the areas below 1 MB, at 16 MB (if present), and at end of the 4-GB address space.
- Standard PC address ranges are not reported. For example, video memory at A0000 to BFFFF physical addresses are not described by this function. The range from E0000 to EFFFF is specific to the baseboard and is reported as it applies to that baseboard.
- All of lower memory is reported as normal memory. The OS must handle standard RAM locations that are reserved for specific uses, such as the interrupt vector table (0:0) and the platform boot firmware data area

(40:0).

15.3 UEFI GetMemoryMap() Boot Services Function

EFI enabled systems use the UEFI *GetMemoryMap()* boot services function to convey memory resources to the OS loader. These resources must then be conveyed by the OS loader to OSPM.

The *GetMemoryMap* interface is only available at boot services time. It is not available as a run-time service after OSPM is loaded. The OS or its loader initiates the transition from boot services to run-time services by calling *ExitBootServices()*. After the call to *ExitBootServices()* all system memory map information must be derived from objects in the ACPI Namespace.

The *GetMemoryMap()* interface returns an array of UEFI memory descriptors. These memory descriptors define a system memory map of all the installed RAM, and of physical memory ranges reserved by the firmware. Each descriptor contains a type field that dictates how the physical address range is to be treated by the operating system. The table below defines the mapping from UEFI memory types (see UEFI Specification) to ACPI *Address Range Types* that:

- Platform boot firmware shall follow if describing the memory range in both UEFI and legacy BIOS modes; and
- An OS loader should use if it conveys that information to the OS using an ACPI E820h system address map table.

Table 15.6: UEFI Memory Types and mapping to ACPI address range types

Type	Mnemonic	ACPI Address Range Type
0	EfiReservedMemoryType	AddressRangeReserved
1	EfiLoaderCode	AddressRangeMemory
2	EfiLoaderData	AddressRangeMemory
3	EfiBootServicesCode	AddressRangeMemory
4	EfiBootServicesData	AddressRangeMemory
5	EfiRuntimeServiceCode	AddressRangeReserved
6	EfiRuntimeServicesData	AddressRangeReserved
7	EfiConventionalMemory	AddressRangeMemory
8	EfiUnusableMemory	AddressRangeReserved
9	EfiACPIReclaimMemory	AddressRangeACPI
10	EfiACPIMemoryNVS	AddressRangeNVS
11	EfiMemoryMappedIO	AddressRangeReserved
12	EfiMemoryMappedIOPort Space	AddressRangeReserved
13	EfiPalCode	AddressRangeReserved
14	EfiPersistentMemory	AddressRangePersistentMemory
15 to 0x6FFFFFFF	Reserved.	AddressRangeReserved
0x70000000 to 0x7FFFFFFF	Reserved for OEM used	An OS should not use a memory type in the vendor-defined range because collisions may occur between different vendors.
0x80000000 to 0xFFFFFFFF	Reserved for use by UEFI OS loaders that are provided by operating system vendors	OSV defined

The table above applies to system firmware that supports legacy BIOS mode plus UEFI mode, and OS loaders.

15.4 UEFI Assumptions and Limitations

- The firmware returns address ranges describing the current system memory configuration.
- The firmware does not return a range description for the memory mapping of PCI devices, ISA Option ROMs, and ISA Plug and Play cards because the OS has mechanisms available to detect them.
- The firmware does not return a range description for address space regions that are not backed by physical hardware except those mentioned above. Regions that are backed by physical hardware, but are not supposed to be accessed by the OS, must be returned as reserved. Herein ‘reserved’ is the definition of the term as noted by the ACPI specification as ACPI address range reserved. OS may use addresses of memory ranges that are not described in the memory map at its own discretion
- Address ranges defined for baseboard memory-mapped I/O devices, such as APICs, are returned as reserved.
- All occurrences of the system firmware are mapped as reserved, including the areas below 1 MB, at 16 MB (if present), and at end of the 4-GB address space. This can include PAL code on Itanium™ Processor Family (IPF)- based platforms.
- Standard PC address ranges are not reported. For example, video memory at A0000 to BFFFF physical addresses are not described by this function. The range from E0000 to EFFFF is specific to the baseboard and is reported as it applies to that baseboard.
- All of lower memory is reported as normal memory. The OS must handle standard RAM locations that are reserved for specific uses, such as the interrupt vector table (0:0) and the platform boot firmware data area (40:0). To preserve backward compatibility, platform should avoid using persistent memory to materialize the lower memory. If persistent memory is used for lower memory, platform boot firmware must report the lower memory address range using AddressRangeMemory and must not report using AddressRangePersistentMemory.
- EFI contains descriptors for memory mapped I/O and memory mapped I/O port space to allow for virtual mode calls to UEFI run-time functions. The OS must never use these regions.

15.5 Example Address Map

This sample address map (for an Intel processor-based system) describes a machine that has 128 MiB of RAM, 640 KiB of base memory and 127 MiB of extended memory. The base memory has 639 KiB available for the user and 1 KiB for an extended BIOS data area. A 4-MiB Linear Frame Buffer (LFB) is based at 12 MiB. The memory hole created by the chip set is from 8 MiB to 16 MiB. Memory-mapped APIC devices are in the system. The I/O Unit is at FEC00000 and the Local Unit is at FEE00000. The system BIOS is remapped to 1 GB-64 KiB.

The 639-KiB endpoint of the first memory range is also the base memory size reported in the BIOS data segment at 40:13. The following table shows the memory map of a typical system.

Table 15.7: Sample Memory Map

Base (Hex)	Length	Type	Description
0000 0000	639 KiB	AddressRangeMemory	Available Base memory. Typically the same value as is returned using the INT 12 function.
0009 FC00	1 KiB	AddressRangeReserved	Memory reserved for use by the BIOS(s). This area typically includes the Extended BIOS data area.
000F 0000	64 KiB	AddressRangeReserved	System BIOS
0010 0000	7 MiB	AddressRangeMemory	Extended memory, which is not limited to the 64-MiB address range.
0080 0000	4 MiB	AddressRangeReserved	Chip set memory hole required to support the LFB mapping at 12 MiB.
0100 0000	60 MiB	AddressRangeMemory	Baseboard RAM relocated above a chip set memory hole.
04C0 0000	60 MiB	AddressRangePersistentMemory	Persistent memory that has non-volatile attributes located in this region.
FEC0 0000	4 KiB	AddressRangeReserved	I/O APIC memory mapped I/O at FEC00000.
FEE0 0000	4 KiB	AddressRangeReserved	Local APIC memory mapped I/O at FEE00000.
FFFF 0000	64 KiB	AddressRangeReserved	Remapped System BIOS at end of address space.

15.6 Example: Operating System Usage

The following code segment illustrates the algorithm to be used when calling the Query System Address Map function. This is an implementation example and uses non-standard mechanisms:

```

E820Present = FALSE;
Reg.ebx = 0;
do {
    Reg.eax = 0xE820;
    Reg.es = SEGMENT (&Descriptor);
    Reg.di = OFFSET (&Descriptor);
    Reg.ecx = sizeof (Descriptor);
    Reg.edx = 'SMAP';

    \_int( 15, regs );

    if ((Regs.eflags & EFLAG_CARRY) \|\| Regs.eax != 'SMAP') {
        break;
    }

    if (Regs.ecx < 20 \|\| reg.ecx > sizeof (Descriptor) ) {
        // bug in bios - all returned descriptors must be
        // at least 20 bytes long, and cannot be larger than
        // the input buffer.
        break;
    }

    E820Present = TRUE;
    .
    .
    .
    Add address range Descriptor.BaseAddress through
    Descriptor.BaseAddress + Descriptor.Length
    as type Descriptor.Type
    .
    .
    .
} while (Regs.ebx != 0);

if (!E820Present) {
    .
    .
    .
    call INT-15 88 and/or INT-15 E801 to obtain old style memory information
    .
    .
    .
}

```

WAKING AND SLEEPING

ACPI defines a mechanism to transition the system between the working state (G0) and a sleeping state (G1) or the soft-off (G2) state. During transitions between the working and sleeping states, the context of the user's operating environment is maintained. ACPI defines the quality of the G1 sleeping state by defining the system attributes of four types of ACPI sleeping states (S1, S2, S3, and S4). Each sleeping state is defined to allow implementations that can tradeoff cost, power, and wake latencies. Additionally, ACPI defines the sleeping states such that an ACPI platform can support multiple sleeping states, allowing the platform to transition into a particular sleeping state for a predefined period of time and then transition to a lower power/higher wake latency sleeping state (transitioning through the G0 state) (*See note below*).

```
OSPM uses the RTC wakeup feature or the Time and Alarm Namespace
device to program in the time transition delay. Prior to sleeping, OSPM
will program the alarm to the closest (in time) wakeup event: either a
transition to a lower power sleeping state, or a calendar event (to run
some application).
```

ACPI defines a programming model that provides a mechanism for OSPM to initiate the entry into a sleeping or soft-off state (S1-S5); this consists of a 3 bit field SLP_TYPx (*See note below*) that indicates the type of sleep state to enter, and a single control bit SLP_EN to start the sleeping process. On HW-reduced ACPI systems, the register described by the SLEEP_CONTROL_REG field in the FADT is used instead of the fixed SLP_TYPx and SLP_EN register bit fields.

```
Notice that there can be two fixed PM1x_CNT registers, each pointing
to a different system I/O space region. Normally a register grouping
only allows a bit or bit field to reside in a single register group
instance (a or b); however, each platform can have two instances of the
SLP_TYP (one for each grouping register: a and b). The \_Sx control
method gives a package with two values: the first is the SLP_TYPa value
and the second is the SLP_TYPb value.
```

Note: Systems containing processors without a hardware mechanism to place the processor in a low-power state may additionally require the execution of appropriate native instructions to place the processor in a low-power state after OSPM sets the SLP_EN bit. The hardware may implement a number of low-power sleeping states and then associate these states with the defined ACPI sleeping states (through the SLP_TYPx fields). The ACPI system firmware creates a sleeping object associated with each supported sleeping state (unsupported sleeping states are identified by the lack of the sleeping object). Each sleeping object contains two constant 3-bit values that OSPM will program into the SLP_TYPa and SLP_TYPb fields (in fixed register space), or, on HW-reduced ACPI platforms, a single 3-bit value that OSPM will write to the register specified by the FADT's SLEEP_CONTROL_REG field.

On systems that are not HW-reduced ACPI platforms, an alternate mechanism for entering and exiting the S4 state is defined. This mechanism passes control to the platform runtime firmware to save and restore platform context. Context ownership is similar in definition to the S3 state, but hardware saves and restores the context of memory to non-volatile

storage (such as a disk drive), and OSPM treats this as an S4 state with implied latency and power constraints. This alternate mechanism of entering the S4 state is referred to as the S4BIOS transition.

Prior to entering a sleeping state (S1-S4), OSPM will execute OEM-specific AML/ASL code contained in the _PTS (Prepare To Sleep) control method. One use of the _PTS control method is that it can indicate to the embedded controller what sleeping state the system will enter. The embedded controller can then respond by executing the proper power-plane sequencing upon sleep state entry.

The _WAK (Wake) control method is then executed. This control method again contains OEM-specific AML/ASL code. One use of the _WAK control method requests OSPM to check the platform for any devices that might have been added or removed from the system while the system was asleep. For example, a PC Card controller might have had a PC Card added or removed, and because the power to this device was off in the sleeping state, the status change event was not generated.

This section discusses the system initialization sequence of an ACPI-enabled platform. This includes the boot sequence, different wake scenarios, and an example to illustrate how to use the system address map reporting interfaces. This sequence is part of the ACPI event programming model.

Note: HW-reduced ACPI platforms do not implement the Legacy Mode nor the S4BIOS state described below.

For detailed information on the power management control methods described above, see *Power and Performance Management*

16.1 Sleeping States

The illustration below shows the transitions between the working state, the sleeping states, and the Soft Off state.

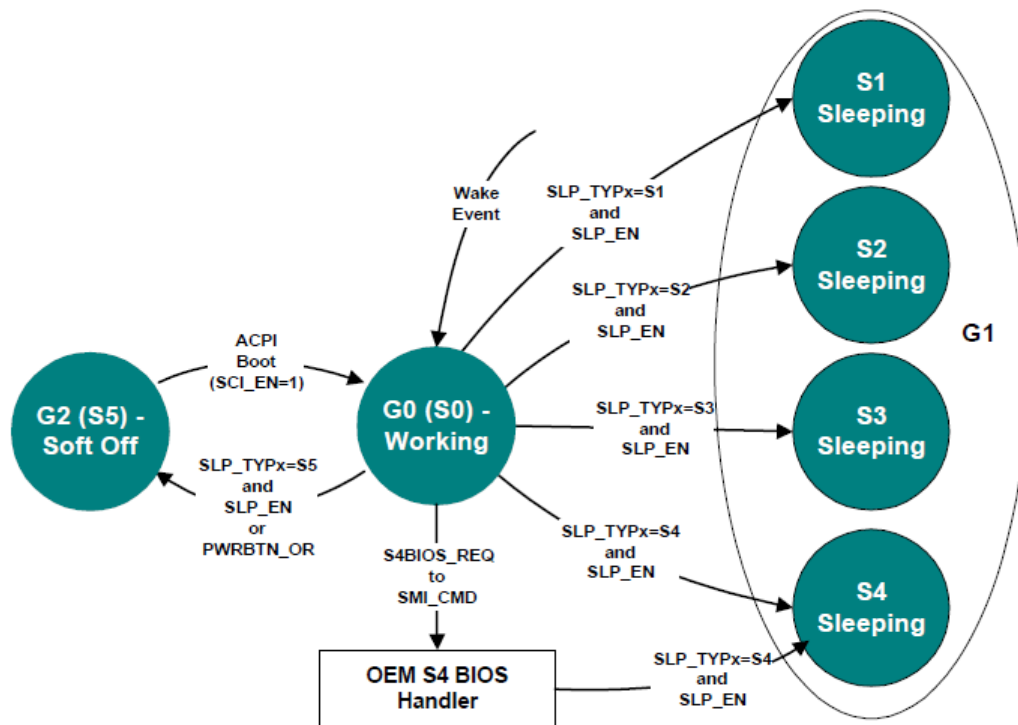

Fig. 16.1: Example Sleeping States

ACPI defines distinct differences between the G0 and G1 system states.

- In the G0 state, work is being performed by the OS/application software and the hardware. The CPU or any particular hardware device could be in any one of the defined power states (C0-C3 or D0-D3); however, some work will be taking place in the system.
- In the G1 state, the system is assumed to be doing no work. Prior to entering the G1 state, OSPM will place devices in a device power state compatible with the system sleeping state to be entered; if a device is enabled to wake the system, then OSPM will place these devices into the lowest Dx state from which the device supports wake. This is defined in the power resource description of that device object. This definition of the G1 state implies:
 - The CPUs execute no instructions in the G1 state.
 - Hardware devices are not operating (except possibly to generate a wake event).
 - If not HW-reduced, ACPI registers are affected as follows:
 - Wake event bits are enabled in the corresponding fixed or general-purpose registers according to enabled wake options.
 - PM1 control register is programmed for the desired sleeping state.
 - WAK_STS is set by hardware in the sleeping state.

All sleeping states have these specifications. ACPI defines additional attributes that allow an ACPI platform to have up to four different sleeping states, each of which has different attributes. The attributes were chosen to allow differentiation of sleeping states that vary in power, wake latency, and implementation cost tradeoffs.

Running processors at reduced levels of performance is not an ACPI sleeping state (G1); this is a working (G0) state-defined event.

The CPU cannot execute any instructions when in the sleeping state; OSPM relies on this fact. A platform designer might be tempted to support a sleeping system by reducing the clock frequency of the system, which allows the platform to maintain a low-power state while at the same time maintaining communication sessions that require constant interaction (as with some network environments). This is definitely a G0 activity where an OS policy decision has been made to turn off the user interface (screen) and run the processor in a reduced performance mode. This type of reduced performance state as a sleeping state is not defined by the ACPI specification; ACPI assumes no code execution during sleeping states.

ACPI defines attributes for four sleeping states: S1, S2, S3 and S4. (Notice that S4 and S5 are very similar from a hardware standpoint.) ACPI-compatible platforms can support multiple sleeping states. ACPI specifies that a 3-bit binary number be associated with each sleeping state (these numbers are given objects within ACPI's root namespace: (_S0, _S1, _S2, _S3, _S4 and _S5). When entering a system sleeping state, OSPM will do the following:

1. Pick the deepest sleeping state supported by the platform and enabled waking devices.
2. Execute the `_PTS` control method (which passes the type of intended sleep state to OEM AML code).
3. If OS policy decides to enter the S4 state and chooses to use the S4BIOS mechanism and S4BIOS is supported by the platform, OSPM will pass control to the platform runtime firmware software by writing the S4BIOS_REQ value to the SMI_CMD port.
4. If not using the S4BIOS mechanism, OSPM gets the SLP_TYPx value from the associated sleeping object (_S1, _S2, _S3, _S4 or _S5).
5. Program the SLP_TYPx fields with the values contained in the selected sleeping object.

Note: Compatibility — The `_GTS` method is deprecated in ACPI 5.0A. For earlier versions, execute the `_GTS` control method, passing an argument that indicates the sleeping state to be entered (1, 2, 3, or 4 representing S1, S2, S3, and S4).

6. If entering S1, S2, or S3, flush the processor caches.
7. If not entering S4BIOS, set the SLP_EN bit to start the sleeping sequence. (This actually occurs on the same write operation that programs the SLP_TYPx field in the PM1_CNT register.) If entering S4BIOS, write the S4BIOS_REQ value into the SMI_CMD port.
8. If HW-reduced, program the register indicated by the SLEEP_CONTROL_REG FADT field with the HW-reduced ACPI Sleep Type value (retrieved from the sleep state object in step 4 above) and with the SLP_EN bit set to one.
9. On systems containing processors without a hardware mechanism to place the processor in a low-power state, execute appropriate native instructions to place the processor in a low-power state.

The `_PTS` control method provides the platform runtime firmware a mechanism for performing some housekeeping, such as writing the sleep type value to the embedded controller, before entering the system sleeping state. Control method execution occurs “just prior” to entering the sleeping state and is not an event synchronized with the write to the `PM1_CNT` register. Execution can take place several seconds prior to the system actually entering the sleeping state. As such, no hardware power-plane sequencing takes place by execution of the `_PTS` control method.

Note: Compatibility — The `_BFS` method is deprecated in ACPI 5.0A. In earlier versions, on waking, the `_BFS` control method is executed. OSPM then executes the `_WAK` control method. This control method executes OEM-specific ASL/AML code that can search for any devices that have been added or removed during the sleeping state.*

The following sections describe the sleeping state attributes.

16.1.1 S1 Sleeping State

The S1 state is defined as a low wake-latency sleeping state. In this state, all system context is preserved with the exception of CPU caches. Before entering S1, OSPM will flush the system caches. If the platform supports the `WBINVD` instruction (as indicated by the `WBINVD` and `WBINVD_FLUSH` flags in the FADT), OSPM will execute the `WBINVD` instruction. The hardware is responsible for maintaining all other system context, which includes the context of the CPU, memory, and chipset.

Examples of S1 sleeping state implementation alternatives follow.

16.1.1.1 Example 1: S1 Sleeping State Implementation

This example references an IA processor that supports the stop grant state through the assertion of the `STPCLK#` signal. When `SLP_TYPx` is programmed to the S1 value (the OEM chooses a value, which is then placed in the `_S1` object) and the `SLP_ENx` bit is subsequently set, or when the HW-reduced ACPI Sleep Type value for S1 and the `SLP_EN` bit are written to the Sleep Control Register, the hardware can implement an S1 state by asserting the `STPCLK#` signal to the processor, causing it to enter the stop grant state.

In this case, the system clocks (PCI and CPU) are still running. Any enabled wake event causes the hardware to deassert the `STPCLK#` signal to the processor whereby OSPM must first invalidate the CPU caches and then transition back into the working state.

16.1.1.2 Example 2: S1 Sleeping State Implementation

When SLP_TYP_x is programmed to the S1 value and the SLP_EN_x bit is subsequently set, or the HW-reduced ACPI Sleep Type value for S1 and the SLP_EN bit are written to the Sleep Control Register, the hardware will implement an S1 sleeping state transition by doing the following:

1. Placing the processor into the stop grant state.
2. Stopping the processor's input clock, placing the processor into the stop clock state.
3. Placing system memory into a self-refresh or suspend-refresh state. Refresh is maintained by the memory itself or through some other reference clock that is not stopped during the sleeping state.
4. Stopping all system clocks (asserts the standby signal to the system PLL chip). Normally the RTC will continue running.

In this case, all clocks in the system have been stopped (except for the RTC). Hardware must reverse the process (restarting system clocks) upon any enabled wake event whereby OSPM must first invalidate the CPU caches and then transition back into the working state.

16.1.2 S2 Sleeping State

The S2 state is defined as a low wake latency sleep state. This state is similar to the S1 sleeping state where any context except for system memory may be lost. Additionally, control starts from the processor's reset vector after the wake event. Before entering S2 the SLP_EN bit, OSPM will flush the system caches. If the platform supports the WBINVD instruction (as indicated by the WBINVD and WBINVD_FLUSH flags in the FADT), OSPM will execute the WBINVD instruction. The hardware is responsible for maintaining chip set and memory context. An example of an S2 sleeping state implementation follows.

16.1.2.1 Example: S2 Sleeping State Implementation

When the SLP_TYP_x register(s) are programmed to the S2 value (found in the _S2 object) and the SLP_EN bit is set, or the HW-reduced ACPI Sleep Type value for S2 and the SLP_EN bit are written to the Sleep Control Register, the hardware will implement an S2 sleeping state transition by doing the following:

1. Stopping system clocks (the only running clock is the RTC).
2. Placing system memory into a self-refresh or suspend-refresh state.
3. Powering off the CPU and cache subsystem.

From S2 Sleeping State the CPU is reset upon detection of the wake event; however, core logic and memory maintain their context. Execution control starts from the CPU's boot vector. The platform boot firmware is required to:

1. Program the initial boot configuration of the CPU (such as the CPU's MSR and MTRR registers).
2. Initialize the cache controller to its initial boot size and configuration.
3. Enable the memory controller to accept memory accesses.
4. Jump to the waking vector.

16.1.3 S3 Sleeping State

The S3 state is defined as a low wake-latency sleep state. From the software viewpoint, this state is functionally the same as the S2 state. The operational difference is that some Power Resources that may have been left ON in the S2 state may not be available to the S3 state. As such, some devices may be in a lower power state when the system is in S3 state than when the system is in the S2 state. Similarly, some device wake events can function in S2 but not S3. An example of an S3 sleeping state implementation follows.

16.1.3.1 Example: S3 Sleeping State Implementation

When the SLP_TYPx register(s) are programmed to the S3 value (found in the _S3 object) and the SLP_EN bit is set, or the HW-reduced ACPI Sleep Type value for S3 and the SLP_EN bit are written to the Sleep Control Register, the hardware will implement an S3 sleeping state transition by doing the following:

1. Placing the memory into a low-power auto-refresh or self-refresh state.
2. Devices that are maintaining memory isolating themselves from other devices in the system.
3. Removing power from the system. At this point, only devices supporting memory are powered (possibly partially powered). The only clock running in the system is the RTC clock.

From S3 Sleeping State, the wake event repowers the system and resets most devices (depending on the implementation). Execution control starts from the CPU's boot vector. The platform boot firmware is required to:

1. Program the initial boot configuration of the CPU (such as the MSR and MTRR registers).
2. Initialize the cache controller to its initial boot size and configuration.
3. Enable the memory controller to accept memory accesses.
4. Jump to the waking vector.

Notice that if the configuration of cache memory controller is lost while the system is sleeping, the platform boot firmware is required to reconfigure it to either the pre-sleeping state or the initial boot state configuration. The platform boot firmware can store the configuration of the cache memory controller into the reserved memory space, where it can then retrieve the values after waking. OSPM will call the _PTS method once per session (prior to sleeping).

The platform boot firmware is also responsible for restoring the memory controller's configuration. If this configuration data is destroyed during the S3 sleeping state, then the platform boot firmware needs to store the pre-sleeping state or initial boot state configuration in a non-volatile memory area (as with RTC CMOS RAM) to enable it to restore the values during the waking process.

When OSPM re-enumerates buses coming out of the S3 sleeping state, it will discover any devices that have been inserted or removed, and configure devices as they are turned on.

16.1.4 S4 Sleeping State

The S4 sleeping state is the lowest-power, longest wake-latency sleeping state supported by ACPI. In order to reduce power to a minimum, it is assumed that the hardware platform has powered off all devices. Because this is a sleeping state, the platform context is maintained. Depending on how the transition into the S4 sleeping state occurs, the responsibility for maintaining system context changes. S4 supports two entry mechanisms: OS initiated and platform runtime firmware-initiated. The OSPM-initiated mechanism is similar to the entry into the S1-S3 sleeping states; OSPM driver writes the SLP_TYPx fields and sets the SLP_EN bit, or writes the HW-reduced ACPI Sleep Type value for S3 and the SLP_EN bit to the Sleep Control Register. The platform runtime firmware-initiated mechanism occurs by OSPM transferring control to the platform runtime firmware by writing the S4BIOS_REQ value to the SMI_CMD port, and is not supported on HW-reduced ACPI platforms.

In OSPM-initiated S4 sleeping state, OSPM is responsible for saving all system context. Before entering the S4 state, OSPM will save context of all memory as specified in *System Address Map Interfaces*.

Upon waking, OSPM shall then restore the system context. When OSPM re-enumerates buses coming out of the S4 sleeping state, it will discover any devices that have come and gone, and configure devices as they are turned on.

In the platform runtime firmware-initiated S4 sleeping state, OSPM is responsible for the same system context as described in the S3 sleeping state (platform runtime firmware restores the memory and some chip set context). The S4BIOS transition transfers control to the platform runtime firmware, allowing it to save context to non-volatile memory (such as a disk partition).

16.1.4.1 Operating System-Initiated S4 Transition

If OSPM supports OSPM-initiated S4 transition, it will not generate a platform firmware-initiated S4 transition. Platforms that support the platform firmware-initiated S4 transition also support OSPM-initiated S4 transition.

OSPM-initiated S4 transition is initiated by OSPM by saving system context, writing the appropriate values to the SLP_TYpX register(s), and setting the SLP_EN bit, or writes the HW-reduced ACPI Sleep Type value for S4 and the SLP_EN bit to the Sleep Control Register. Upon exiting the S4 sleeping state, the platform boot firmware restores the chipset to its POST condition, updates the hardware signature (described later in this section), and passes control to OSPM through a normal boot process.

When the platform boot firmware builds the ACPI tables, it generates a hardware signature for the system. If the hardware configuration has changed during an OS-initiated S4 transition and it changes the content or structure of the ACPI tables, the platform boot firmware updates the hardware signature in the FACS table as described in Section 5.2.10 (Firmware ACPI Control Structure (FACS)).

Upon waking, in order to locate the hardware signature, the physical address of the RSDP must be reacquired via methods described in 5.2.5.1 (Finding the RSDP on IA-PC Systems) or 5.2.5.2 (Finding the RSDP on UEFI Enable Systems) and therefore it must not be assumed that the FACS and its Hardware Signature would be located in the same physical memory address as the prior boot.

16.1.4.2 The S4BIOS Transition

This transition is not supported on HW-reduced ACPI platforms. On other systems, the platform runtime firmware-initiated S4 transition begins with OSPM writing the S4BIOS_REQ value into the SMI_CMD port (as specified in the FADT). Once gaining control, the platform runtime firmware then saves the appropriate memory and chip set context, and then places the platform into the S4 state (power off to all devices).

In the FACS memory table, there is the S4BIOS_F bit that indicates hardware support for the platform runtime firmware-initiated S4 transition. If the hardware platform supports the S4BIOS state, it sets the S4BIOS_F flag within the FACS memory structure prior to booting the OS. If the S4BIOS_F flag in the FACS table is set, this indicates that OSPM can request the platform runtime firmware to transition the platform into the S4BIOS sleeping state by writing the S4BIOS_REQ value (found in the FADT) to the SMI_CMD port (identified by the SMI_CMD value in the FADT).

Upon waking the platform boot firmware restores memory context and jumps to the waking vector (similar to wake from an S3 state). Coming out of the S4BIOS state, the platform boot firmware must only configure boot devices (so it can read the disk partition where it saved system context). When OSPM re-enumerates buses coming out of the S4BIOS state, it will discover any devices that have come and gone, and configure devices as they are turned on.

16.1.5 S5 Soft Off State

OSPM places the platform in the S5 soft off state to achieve a logical off. Notice that *the S5 state is not a sleeping state* (it is a G2 state) and no context is saved by OSPM or hardware but power may still be applied to parts of the platform in this state, and, as such, it is not safe to disassemble. Also notice that from a hardware perspective, the S4 and S5 states are nearly identical. When initiated, the hardware will sequence the system to a state similar to the off state. The hardware has no responsibility for maintaining any system context (memory or I/O); however, it does allow a transition to the S0 state due to a power button press or a Remote Start. Upon start-up, the platform boot firmware performs a normal power-on reset, loads the boot sector, and then executes (but not the waking vector, as all ACPI table context is lost when entering the S5 soft off state).

The `_TTS` control method allows the platform runtime firmware a mechanism for performing some housekeeping, such as storing the targeted sleep state in a “global” variable that is accessible by other control methods (such as `_PS3` and `_DSW`).

16.1.6 Transitioning from the Working to the Sleeping State

On a transition of the system from the working to the sleeping state, the following occurs:

1. OSPM decides (through a policy scheme) to place the system into the sleeping state.
2. OSPM invokes the `_TTS` method to indicate the deepest possible system state the system will transition to (1, 2, 3, or 4 representing S1, S2, S3, and S4).
3. OSPM examines all devices enabled to wake the system and determines the deepest possible sleeping state the system can enter to support the enabled wake functions. The `_PRW` named object under each device is examined, as well as the power resource object it points to.
4. OSPM places all device drivers into their respective Dx state. If the device is enabled for wake, it enters the Dx state associated with the wake capability. If the device is not enabled to wake the system, it enters the D3 state.
5. OSPM executes the `_PTS` control method, passing an argument that indicates the desired sleeping state (1, 2, 3, or 4 representing S1, S2, S3, and S4).
6. OSPM saves any other processor’s context (other than the local processor) to memory.
7. OSPM writes the waking vector into the FACS table in memory.

Note: Compatibility — The `_GTS` method is deprecated in ACPI 5.0A. For earlier versions, OSPM executes the `_GTS` control method, passing an argument that indicates the sleeping state to be entered (1, 2, 3, or 4 representing S1, S2, S3, and S4).*

8. If not a HW-reduced ACPI platform, OSPM clears the `WAK_STS` in the `PM1a_STS` and `PM1b_STS` registers. On HW-reduced ACPI platforms, OSPM clears the `WAK_STS` bit in the Sleep Status Register.
9. OSPM saves the local processor’s context to memory.
10. OSPM flushes caches (only if entering S1, S2 or S3).
11. OSPM sets GPE enable registers or enables wake-capable interrupts to ensure that all appropriate wake signals are armed.
12. If entering an S4 state using the S4BIOS mechanism, OSPM writes the `S4BIOS_REQ` value (from the FADT) to the `SMI_CMD` port. This passes control to the platform runtime firmware, which then transitions the platform into the S4BIOS state.
13. If not entering an S4BIOS state, and not a HW-reduced ACPI platform, then OSPM writes `SLP_TYPa` (from the associated sleeping object) with the `SLP_ENa` bit set to the `PM1a_CNT` register.

- OSPM writes SLP_TYPb with the SLP_EN bit set to the PM1b_CNT register, or writes the HW-reduced ACPI Sleep Type value and the SLP_EN bit to the Sleep Control Register.
- On systems containing processors without a hardware mechanism to place the processor in a low-power state, OSPM executes appropriate native instructions to place the processor in a low-power state.
- OSPM loops on the WAK_STS bit, either in both the PM1a_CNT and PM1b_CNT registers, or in the SLEEP_STATUS_REG, in the case of HW-reduced ACPI platforms.
- The system enters the specified sleeping state.

Note: This is accomplished after step 14 or 15 above.

16.1.7 Transitioning from the Working to the Soft Off State

On a transition of the system from the working to the soft off state, the following occurs:

- OSPM executes the _PTS control method, passing the argument 5.
- OSPM prepares its components to shut down (flushing disk caches).

Note: Compatibility — The _GTS method is deprecated in ACPI 5.0A. For earlier versions, OSPM executes the _GTS control method, passing the argument 5.

- If not a HW-reduced ACPI platform, OSPM writes SLP_TYPa (from the _S5 object) with the SLP_ENa bit set to the PM1a_CNT register.
- OSPM writes SLP_TYPb (from the _S5 object) with the SLP_ENb bit set to the PM1b_CNT register, or writes the HW-reduced ACPI Sleep Type value for S5 and the SLP_EN bit to the Sleep Control Register.
- The system enters the Soft Off state.

16.2 Flushing Caches

Before entering the S1, S2 or S3 sleeping states, OSPM is responsible for flushing the system caches. ACPI provides a number of mechanisms to flush system caches. These include:

- Using a native instruction (for example, the IA-32 architecture WBINVD instruction) to flush and invalidate platform caches.
 - WBINVD_FLUSH flag set (1) in the FADT indicates the system provides this support level.
- Using the IA-32 instruction WBINVD to flush but **not** invalidate the platform caches.
 - WBINVD flag set (1) in the FADT indicates the system provides this support level.

The manual flush mechanism has two caveats:

- Largest cache is **1 MB** in size (**FLUSH_SIZE** is a maximum value of **2 MB**).
- No victim caches (for which the manual flush algorithm is unreliable).

Processors with built-in victim caches will not support the manual flush mechanism and are therefore required to support the WBINVD mechanism to use the S2 or S3 state.

The manual cache-flushing mechanism relies on the two FADT fields:

- **FLUSH_SIZE.** Indicates twice the size of the largest cache in bytes.
- **FLUSH_STRIDE.** Indicates the smallest line size of the caches in bytes.

The cache flush size value is typically twice the size of the largest cache size, and the cache flush stride value is typically the size of the smallest cache line size in the platform. OSPM will flush the system caches by reading a contiguous block of memory indicated by the cache flush size.

16.3 Initialization

This section covers the initialization sequences for an ACPI platform. After a reset or wake from an S2, S3, or S4 sleeping state (as defined by the ACPI sleeping state definitions), the CPU will start execution from its boot vector. At this point, the initialization software has many options, depending on what the hardware platform supports. This section describes at a high level what should be done for these different options. The figure below illustrates the flow of the boot-up software.

The processor will start executing at its power-on reset vector when waking from an S2, S3, or S4 sleeping state, during a power-on sequence, or as a result of a hard or soft reset.

When executing from the power-on reset vector as a result of a power-on sequence, a hard or soft reset, **or waking from an S4 sleep state**, the platform firmware performs complete hardware initialization; placing the system in a boot configuration. The firmware then passes control to the operating system boot loader.

When executing from the power-on reset vector as a result of waking from an S2 or S3 sleep state, the platform firmware performs only the hardware initialization required to restore the system to either the state the platform was in prior to the initial operating system boot, or to the pre-sleep configuration state. In multiprocessor systems, non-boot processors should be placed in the same state as prior to the initial operating system boot. The platform firmware then passes control back to OSPM system by jumping to either the `Firmware_Waking_Vector` or the `X_Firmware_Waking_Vector` in the FACS (see *Firmware ACPI Control Structure (FACS)* for more information). The contents of operating system memory contents may not be changed during the S2 or S3 sleep state.

First, the platform runtime firmware determines whether this is a wake from S2 or S3 by examining the `SLP_TYP` register value, which is preserved between sleeping sessions. If this is an S2 or S3 wake, then the platform runtime firmware restores minimum context of the system before jumping to the waking vector. This includes:

CPU configuration. Platform runtime firmware restores the pre-sleep configuration or initial boot configuration of each CPU (MSR, MTRR, firmware update, SMBase, and so on). Interrupts must be disabled (for IA-32 processors, disabled by CLI instruction).

Memory controller configuration. the configuration is lost during the sleeping state, the platform runtime firmware initializes the memory controller to its pre-sleep configuration or initial boot configuration.

Cache memory configuration. If the configuration is lost during the sleeping state, the platform runtime firmware initializes the cache controller to its pre-sleep configuration or initial boot configuration.

Functional device configuration. The platform runtime firmware doesn't need to configure/restore context of functional devices such as a network interface (even if it is physically included in chipset) or interrupt controller. OSPM is responsible for restoring all context of these devices. The only requirement for the hardware and platform runtime firmware is to ensure that interrupts are not asserted by devices when the control is passed to OS.

ACPI registers. `SCI_EN` bit must be set on non-HW-reduced ACPI platforms, and all event status/enable bits (`PM1x_STS`, `PM1x_EN`, `GPEx_STS` and `GPEx_EN`) must not be changed by platform runtime firmware.

Note: The platform runtime firmware may reconfigure the CPU, memory controller, and cache memory controller to either the pre-sleeping configuration or the initial boot configuration. OSPM must accommodate both configurations.

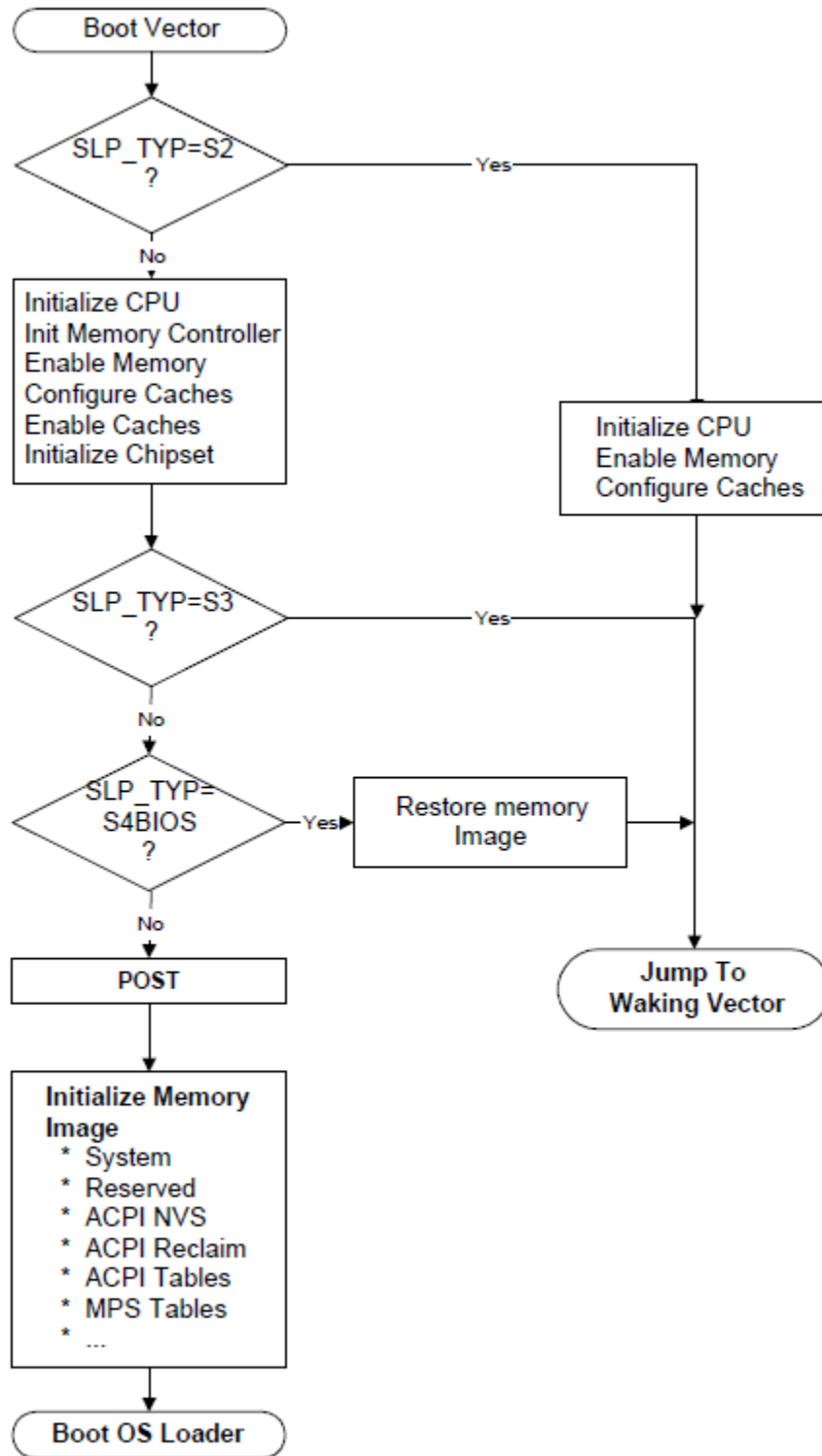

Fig. 16.2: Platform Firmware Initialization

When waking from an S4BIOS sleeping state, the platform boot firmware initializes a minimum number of devices such as CPU, memory, cache, chipset and boot devices. After initializing these devices, the platform boot firmware restores memory context from non-volatile memory such as hard disk, and jumps to waking vector.

As mentioned previously, waking from an S4 state is treated the same as a cold boot: the platform boot firmware runs POST and then initializes memory to contain the ACPI system description tables. After it has finished this, it can call OSPM loader, and control is passed to OSPM.

When waking from S4 (either S4OS or S4BIOS), the platform boot firmware may optionally set SCI_EN bit before passing control to OSPM. In this case, interrupts must be disabled (for IA-32 processors, disabled CLI instruction) until the control is passed to OSPM and the chipset must be configured in ACPI mode.

16.3.1 Placing the System in ACPI Mode

When a platform initializes from a cold boot (mechanical off or from an S4 or S5 state), the hardware platform may be configured in a legacy configuration, if not a HW-reduced ACPI platform. From these states, the platform boot firmware software initializes the computer as it would for a legacy operating system. When control is passed to the operating system, OSPM will check the SCI_EN bit and if it is not set will then enable ACPI mode by first finding the ACPI tables, and then by generating a write of the ACPI_ENABLE value to the SMI_CMD port (as described in the FADT). The hardware platform will set the SCI_EN bit to indicate to OSPM that the hardware platform is now configured for ACPI.

Note: Before SCI is enabled, no SCI interrupt can occur. Nor can any SCI interrupt occur immediately after ACPI is on. The SCI interrupt can only be signaled after OSPM has enabled one of the GPE/PM1 enable bits.

When the platform is waking from an S1, S2 or S3 state, and from S4 and S5 on HW-reduced ACPI platforms, OSPM assumes the hardware is already in the ACPI mode and will not issue an ACPI_ENABLE command to the SMI_CMD port

16.3.2 Platform Boot Firmware Initialization of Memory

During a power-on reset, an exit from an S4 sleeping state, or an exit from an S5 soft-off state, the platform boot firmware needs to initialize memory. This section explains how the platform boot firmware should configure memory for use by a number of features including:

- ACPI tables.
- Platform firmware memory that wants to be saved across S4 sleeping sessions and should be cached.
- Platform firmware memory that does not require saving and should be cached.

For example, the configuration of the platform's cache controller requires an area of memory to store the configuration data. During the wake sequence, the platform boot firmware will re-enable the memory controller and can then use its configuration data to reconfigure the cache controllers. To support these three items, IA-PC-based systems contain *System Address Map Interfaces* that return the following memory range types:

ACPI Reclaim Memory. Memory identified by the platform boot firmware that contains the ACPI tables. This memory can be any place above 8 MB and contains the ACPI tables. When OSPM is finished using the ACPI tables, it is free to reclaim this memory for system software use (application space).

ACPI Non-Volatile-Sleeping Memory (NVS). Memory identified by the BIOS as being reserved by the platform boot firmware for its use. OSPM is required to tag this memory as cacheable, and to save and restore its image before entering an S4 state. Except as directed by control methods, OSPM is not allowed to use this physical memory. OSPM will call the _PTS control method some time before entering a sleeping state, to allow the platform's AML code to update this memory image before entering the sleeping state. After the system awakes

from an S4 state, OSPM will restore this memory area and call the `_WAK` control method to enable the platform boot firmware to reclaim its memory image.

Note: The memory information returned from the system address map reporting interfaces should be the same before and after an S4 sleep.

When the system is first booting, OSPM will invoke E820 interfaces on IA-PC-based legacy systems or the `GetMemoryMap()` interface on UEFI-enabled systems to obtain a system memory map, *System Address Map Interfaces* for more information). As an example, the following memory map represents a typical IA-PC-based legacy platform’s physical memory map.

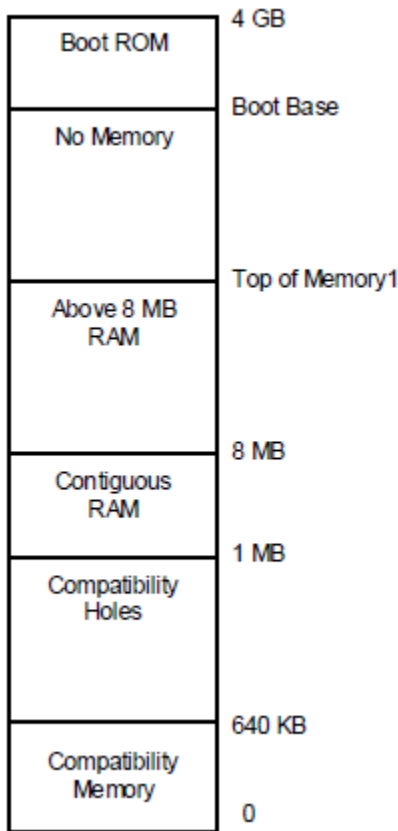

Fig. 16.3: Example Physical Memory Map

The names and attributes of the different memory regions are listed below:

- **0-640 KB.** Compatibility Memory. Application executable memory for an 8086 system.
- **640 KB-1 MB.** Compatibility Holes. Holes within memory space that allow accesses to be directed to the PC-compatible frame buffer (A0000h-BFFFFh), to adapter ROM space (C0000h-DFFFFh), and to system platform firmware space (E0000h-FFFFFh).
- **1 MB-8 MB.** Contiguous RAM. An area of contiguous physical memory addresses. Operating systems may require this memory to be contiguous in order for its loader to load the OS properly on boot up. (No memory-mapped I/O devices should be mapped into this area.)
- **8 MB-Top of Memory1.** This area contains memory to the “top of memory1” boundary. In this area, memory-mapped I/O blocks are possible.

- **Boot Base-4 GB.** This area contains the bootstrap ROM.

The platform boot firmware should decide where the different memory structures belong, and then configure the E820 handler to return the appropriate values.

For this example, the platform boot firmware will report the system memory map by E820 as shown in Figure 15-4. Notice that the memory range from 1 MB to top of memory is marked as system memory, and then a small range is additionally marked as ACPI reclaim memory. A legacy OS that does not support the E820 extensions will ignore the extended memory range calls and correctly mark that memory as system memory.

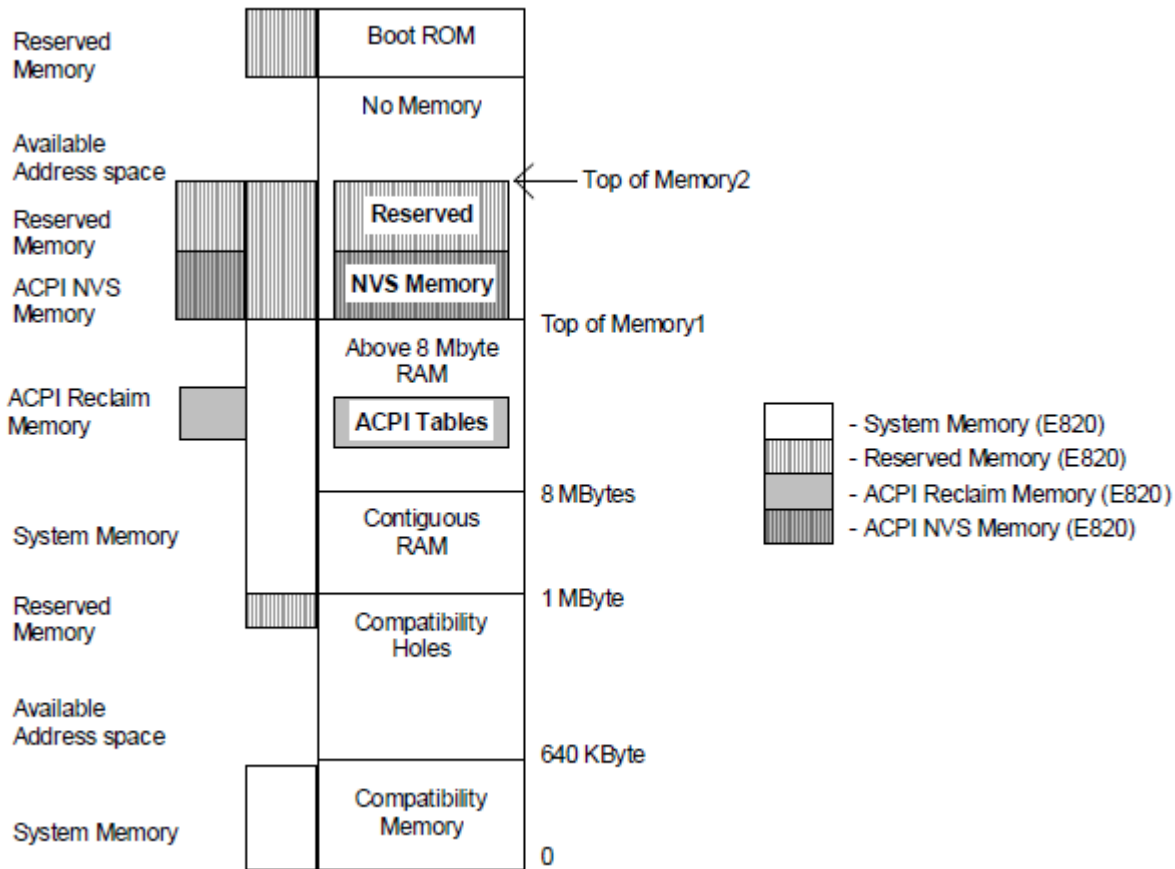

Fig. 16.4: Memory as Configured after Boot

Also, from the Top of Memory1 to the Top of Memory2, the platform boot firmware has set aside some memory for its own use and has marked as reserved both ACPI NVS Memory and Reserved Memory. A legacy OS will throw out the ACPI NVS Memory and correctly mark this as reserved memory (thus preventing this memory range from being allocated to any add-in device).

OSPM will call the `_PTS` control method prior to initiating a sleep (by programming the sleep type, followed by setting the `SLP_EN` bit). During a catastrophic failure (where the integrity of the AML code interpreter or driver structure is questionable), if OSPM decides to shut the system off, it will not issue a `_PTS`, but will immediately issue a `SLP_TYP` of “soft off” and then set the `SLP_EN` bit, or directly write the HW-reduced ACPI Sleep Type value and the `SLP_EN` bit to the Sleep Control Register. Hence, the hardware should not rely solely on the `_PTS` control method to sequence the system to the “soft off” state. After waking from an S4 state, OSPM will restore the ACPI NVS memory image and then issue the `_WAK` control method that informs platform runtime firmware that its memory image is back.

16.3.3 OS Loading

At this point, the platform boot firmware has passed control to OSPM, either by using OSPM boot loader (a result of waking from an S4/S5 or boot condition) or OSPM waking vector (a result of waking from an S2 or S3 state). For the Boot OS Loader path, OSPM will get the system address map via one of the mechanisms describe in *System Address Map Interfaces*. If OSPM is booting from an S4 state, it will then check the NVS image file's hardware signature with the hardware signature within the FACS table (built by platform boot firmware) to determine whether it has changed since entering the sleeping state (indicating that the platforms fundamental hardware configuration has changed during the current sleeping state). If the signature has changed, OSPM will not restore the system context and can boot from scratch (from the S4 state). Next, for an S4 wake, OSPM will check the NVS file to see whether it is valid. If valid, then OSPM will load the NVS image into system memory. Next, if not a HW-reduced ACPI platform, OSPM will check the SCI_EN bit and if it is not set, will write the ACPI_ENABLE value to the SMI_CMD register to switch into the system into ACPI mode and will then reload the memory image from the NVS file.

If an NVS image file did not exist, then OSPM loader will load OSPM from scratch. At this point, OSPM will generate a _WAK call that indicates to the platform runtime firmware that its ACPI NVS memory image has been successfully and completely updated.

16.3.4 Exiting ACPI Mode

For machines that do not boot in ACPI mode, ACPI provides a mechanism that enables the OS to disable ACPI. The following occurs:

1. OSPM unloads all ACPI drivers (including the ACPI driver).
2. OSPM disables all ACPI events.
3. OSPM finishes using all ACPI registers.
4. OSPM issues an I/O access to the port at the address contained in the SMI_CMD field (in the FADT) with the value contained in the ACPI_DISABLE field (in the FADT).
5. Platform runtime firmware then remaps all SCI events to legacy events and resets the SCI_EN bit.
6. Upon seeing the SCI_EN bit cleared, the ACPI OS enters the legacy OS mode.

When and if the legacy OS returns control to the ACPI OS, if the legacy OS has not maintained the ACPI tables (in reserved memory and ACPI NVS memory), the ACPI OS will reboot the system to allow the platform runtime firmware to re-initialize the tables.

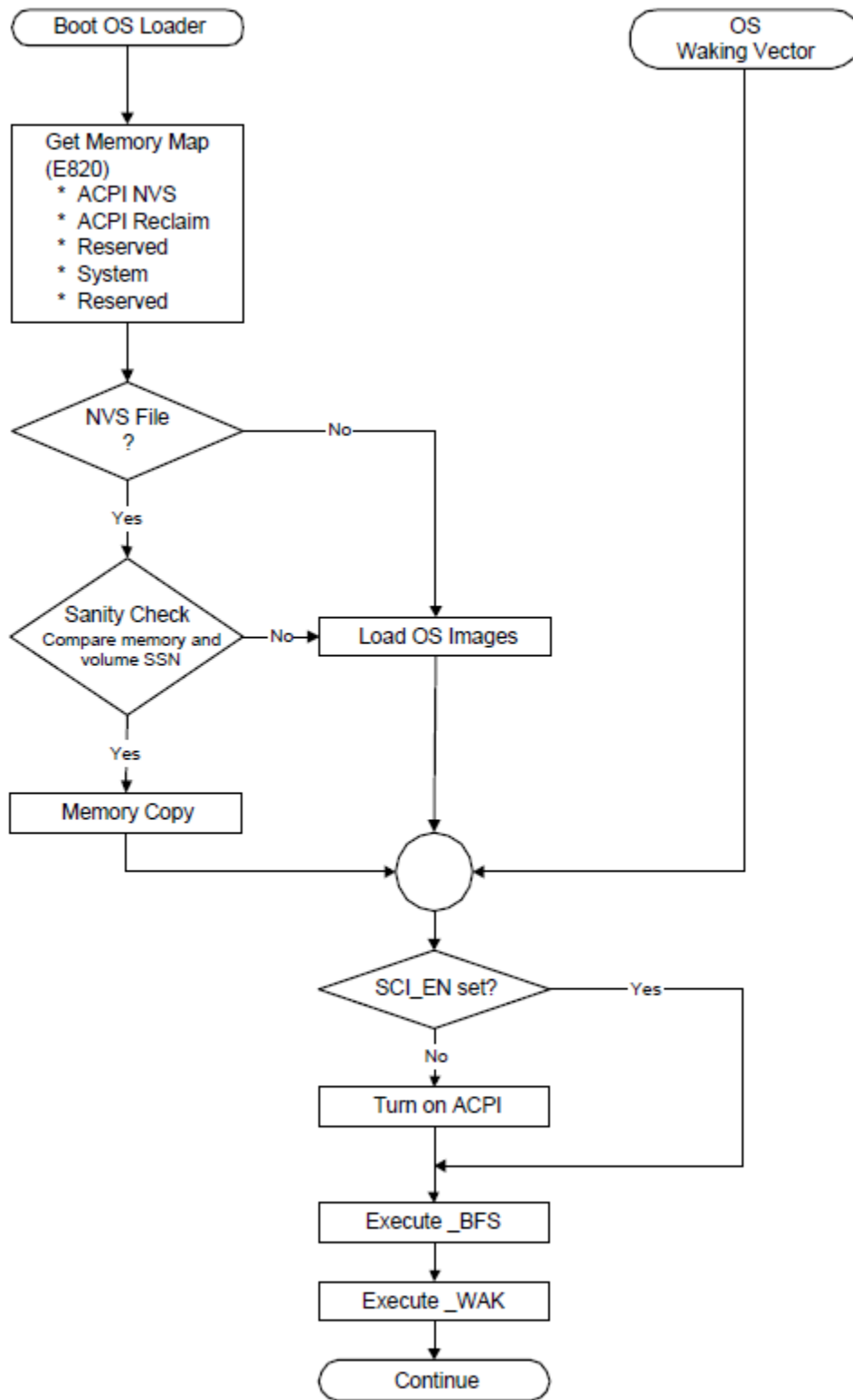

Fig. 16.5: OS Initialization

NON-UNIFORM MEMORY ACCESS (NUMA) ARCHITECTURE PLATFORMS

Systems employing a Non Uniform Memory Access (NUMA) architecture contain collections of hardware resources including processors, memory, and I/O buses, that comprise what is commonly known as a “NUMA node”. Two or more NUMA nodes are linked to each other via a high-speed interconnect. Processor accesses to memory or I/O resources within the local NUMA node are generally faster than processor accesses to memory or I/O resources outside of the local NUMA node, accessed via the node interconnect. ACPI defines interfaces that allow the platform to convey NUMA node topology information to OSPM both statically at boot time and dynamically at run time as resources are added or removed from the system.

In addition, devices such as coherent accelerators, coherent memory devices, or coherent switches can describe their NUMA characteristics information to OSPM or to system firmware using the Coherent Device Attribute Table (CDAT) structures. For more information, see the CDAT reference link at <http://uefi.org/acpi>, under the heading “Coherent Device Attribute Table (CDAT) Specification”.

17.1 NUMA Node

A conceptual model for a node in a NUMA configuration may contain one or more of the following components:

- Processor
- Memory
- I/O Resources
- Networking, Storage
- Chipset

The components defined as part of the model are intended to represent all possible components of a NUMA node. A specific node in an implementation of a NUMA platform may not provide all of these components. At a minimum, each node must have a chipset with an interface to the interconnect between nodes.

The defining characteristic of a NUMA system is a coherent global memory and/or I/O address space that can be accessed by all of the processors. Hence, at least one node must have memory, at least one node must have I/O resources, and at least one node must have processors. Other than the chipset, which must have components present on every node, each is implementation dependent. In the ACPI namespace, NUMA nodes are described as module devices. See the *Module Device* section.

17.2 System Locality

A collection of components that are presented to OSPM as a Symmetrical Multi-Processing (SMP) unit belong to the same System Locality, also known as a Proximity Domain. The granularity of a System Locality is typically at the NUMA Node level although the granularity can also be at the sub-NUMA node level or the processor, memory and host bridge level.

A System Locality is reported to the OSPM using Proximity Domain entries in the System Resource Affinity Table (SRAT), or using `_PXM (Proximity)` methods in the ACPI namespace. If OSPM only needs to know a near/far distinction among the System Localities, comparing Proximity Domain values is sufficient. See the *System Resource Affinity Table (SRAT)* and *_PXM (Proximity)* sections for more information.

OSPM makes no assumptions about the proximity or nearness of different proximity domains. The difference between two integers representing separate proximity domains does not imply distance between the proximity domains (in other words, proximity domain 1 is not assumed to be closer to proximity domain 0 than proximity domain 6).

17.2.1 System Resource Affinity Table Definition

The optional *System Resource Affinity Table (SRAT)* provides the boot time description of the processor and memory ranges belonging to a system locality. OSPM will consume the SRAT only at boot time. For any devices not in the SRAT, OSPM should use `_PXM (Proximity)` for them or their ancestors that are hot-added into the system after boot up.

The SRAT describes the system locality that all processors and memory present in a system belong to at system boot. This includes memory that can be hot-added (that is memory that can be added to the system while it is running, without requiring a reboot). OSPM can use this information to optimize the performance of NUMA architecture systems. For example, OSPM could utilize this information to optimize allocation of memory resources and the scheduling of software threads.

17.2.2 System Resource Affinity Update

Dynamic migration of the devices may cause the relative system resource affinity information (if the optional SRAT is present) to change. If this occurs, the System Resource Affinity Update notification (Notify event of type 0x0D) may be generated by the platform to a device at a point on the device tree that represents a System Resource Affinity. This indicates to OSPM to invoke the `_PXM (Proximity)` object of the notified device to update the resource affinity.

17.3 System Locality Distance Information

Optionally, OSPM may further optimize a NUMA architecture system using information about the relative memory latency distances among the System Localities. This may be useful if the distance between multiple system localities is significantly different. In this case, a simple near/far distinction may be insufficient. This information is contained in the optional *System Locality Information Table*, and is returned from the evaluation of the `_SLI` object.

The SLIT is a matrix that describes the relative distances between all System Localities. To include devices that are not in the System Resource Affinity Table (SRAT), support for the `_PXM` object is required. The Proximity Domain values from SRAT, or the values returned by the `_PXM` objects are used as the row and column indices of the matrix.

Implementation Note: The size of the SLIT is determined by the largest Proximity Domain value used in the system. Hence, to minimize the size of the SLIT, the Proximity Domain values assigned by the system firmware should be in the range 0, . . . , N-1, where N is the number of System Localities. If Proximity Domain values are not packed into this range, the SLIT will still work, but more memory will have to be allocated to store the “Entries” portion of the SLIT for the matrix.

The static SLIT table provides the boot time description of the relative distances among all System Localities. For hot-added devices and dynamic reconfiguration of the system localities, the `_SLI` object must be used for runtime update.

The `_SLI` method is an optional object that provides the runtime update of the relative distances from the System Locality `i` to all other System Localities in the system. Since `_SLI` method is providing additional relative distance information among System Localities, if implemented, it is provided alongside with the `_PXM` method.

17.3.1 Online Hot Plug

In the case of online device addition, the Bus Check notification (0x0) is performed on a device object to indicate to OSPM that it needs to perform the Plug and Play re-enumeration operation on the device tree starting from the point where it has been notified. OSPM needs to evaluate all `_PXM` objects associated with the added devices, and `_SLI` objects if the SLIT is present.

In the case of online device removal, OSPM needs to perform the Plug and Play ejection operation when it receives the Eject Request notification (0x03). OSPM needs to remove the relative distance information from its internal data structure for the removed devices.

17.3.2 Impact to Existing Localities

Dynamic reconfiguration of the system may cause the relative distance information (if the optional SLIT is present) to become stale. If this occurs, the “System Locality Information Update” notification (Notify event of type 0xB) may be generated by the platform to a device at a point on the device tree that represents a System Locality. This indicates to OSPM that it needs to invoke the `_SLI` objects associated with the System Localities on the device tree starting from the point where it has been notified.

17.4 Heterogeneous Memory Attributes Information

Optionally, OSPM may further optimize a NUMA architecture system using the Heterogeneous Memory Attributes. This may be useful if the memory latency and bandwidth attributes between system localities is significantly different. In this case, the information is contained in the optional Heterogeneous Memory Attributes (HMAT) and is returned from the evaluation of the `_HMA` object.

The HMAT structure describes the latency and bandwidth information between memory access Initiator and memory Target System Localities. System Locality proximity domain identifiers, as defined by Proximity Domain entries in the System Resource Affinity Table (SRAT), or as returned by `_PXM` object, are used in the HMAT structure.

Implementation Note: The size of the HMAT table is determined by number of memory initiator System Localities and the memory target System Localities. The static HMAT table provides the boot time description of the memory latency and bandwidth among all memory access Initiator and memory Target System Localities. For hot-added devices and dynamic reconfiguration of the system localities, the `_HMA` object must be used for runtime update.

The `_HMA` method is an optional object that provides the runtime update of the latency and bandwidth from the memory access Initiator System Locality “`i`” to all other memory Target System Localities “`j`” in the system.

Since `_HMA` method is providing additional memory latency and bandwidth information among System Localities, if implemented, it is provided alongside with the `_PXM` method.

17.4.1 Online Hot Plug

In the case of online device addition, the “Bus Check” notification (0x0) is performed on a device object to indicate to OSPM that it needs to perform the Plug and Play re-enumeration operation on the device tree starting from the point where it has been notified. OSPM needs to evaluate all `_PXM` objects associated with the added devices, and `_HMA` objects if the HMAT is present.

In the case of online device removal, OSPM needs to perform the Plug and Play ejection operation when it receives the “Eject Request” notification (0x03). OSPM needs to remove the ejected System Localities related information from its internal data structure for the removed devices.

17.4.2 Impact to Existing Localities

Dynamic reconfiguration of the system may cause the memory latency and bandwidth information (if the optional HMAT is present) to become stale. If this occurs, the Heterogeneous Memory Attributes Update notification (Notify event of type 0xE) may be generated by the platform to a device at a point on the device tree that represents a System Locality. This indicates to OSPM that it needs to invoke the `_HMA` objects associated with the System Localities on the device tree starting from the point where it has been notified.

ACPI PLATFORM ERROR INTERFACES (APEI)

This section describes the ACPI Platform Error Interfaces (APEI), which provide a means for a computer platform to convey error information to OSPM. APEI extends existing hardware error reporting mechanisms and brings them together as components of a coherent hardware error infrastructure. APEI takes advantage of the additional hardware error information available in today's hardware devices, and integrates much more closely with the system firmware.

As a result, APEI provides the following benefits:

- Allows for more extensive error data to be made available in a standard error record format for determining the root cause of hardware errors.
- Is extensible, so that as hardware vendors add new and better hardware error reporting mechanisms to their devices, APEI allows the platform and the OSPM to gracefully accommodate the new mechanisms.

This provides information to help system designers understand basic issues about hardware errors, the relationship between the firmware and OSPM, and information about error handling and the APEI architecture components.

APEI consists of four separate tables:

- Error Record Serialization Table (ERST)
- Boot Error Record Table (BERT)
- Hardware Error Source Table (HEST)
- Error Injection Table (EINJ)

18.1 Hardware Errors and Error Sources

A hardware error is a recorded event related to a malfunction of a hardware component in a computer platform. The hardware components contain error detection mechanisms that detect when a hardware error condition exists. Hardware errors can be classified as either corrected errors or uncorrected errors as follows:

- A corrected error is a hardware error condition that has been corrected by the hardware or by the firmware by the time the OSPM is notified about the existence of the error condition.
- An uncorrected error is a hardware error condition that cannot be corrected by the hardware or by the firmware. Uncorrected errors are either fatal or non-fatal.
- A fatal hardware error is an uncorrected or uncontained error condition that is determined to be unrecoverable by the hardware. When a fatal uncorrected error occurs, the system is restarted to prevent propagation of the error.
- A non-fatal hardware error is an uncorrected error condition from which OSPM can attempt recovery by trying to correct the error. These are also referred to as correctable or recoverable errors.

Central to APEI is the concept of a hardware error source. A hardware error source is any hardware unit that alerts OSPM to the presence of an error condition. Examples of hardware error sources include the following:

- Processor machine check exception (for example, MC#)
- Chipset error message signals (for example, SCI, SMI, SERR#, MCERR#)
- I/O bus error reporting (for example, PCI Express root port error interrupt)
- I/O device errors

A single hardware error source might handle aggregate error reporting for more than one type of hardware error condition. For example, a processor's machine check exception typically reports processor errors, cache and memory errors, and system bus errors.

A hardware error source is typically represented by the following:

- One or more hardware error status registers.
- One or more hardware error configuration or control registers.
- A signaling mechanism to alert OSPM to the existence of an error condition.

In some situations, there is not an explicit signaling mechanism and OSPM must poll the error status registers to test for an error condition. However, polling can only be used for corrected error conditions since uncorrected errors require immediate attention by OSPM.

18.2 Relationship between OSPM and System Firmware

Both OSPM and system firmware play important roles in hardware error handling. APEI improves the methods by which both of these can contribute to the task of hardware error handling in a complementary fashion. APEI allows the hardware platform vendor to determine whether the firmware or OSPM will own key hardware error resources. APEI also allows the firmware to pass control of hardware error resources to OSPM when appropriate.

18.3 Error Source Discovery

Platforms enumerate error sources to OSPM via a set of tables that describe the error sources. OSPM may also support non-ACPI enumerated error sources such as: Machine Check Exception, Corrected Machine Check, NMI, PCI Express AER, and on Itanium™ Processor Family (IPF) platforms the INIT error source. Non-ACPI error sources are not described by this specification.

During initialization, OSPM examines the tables and uses this information to establish the necessary error handlers that are responsible for processing error notifications from the platform.

18.3.1 Boot Error Source

Under normal circumstances, when a hardware error occurs, the error handler receives control and processes the error. This gives OSPM a chance to process the error condition, report it, and optionally attempt recovery. In some cases, the system is unable to process an error. For example, system firmware or a management controller may choose to reset the system or the system might experience an uncontrolled crash or reset.

The boot error source is used to report unhandled errors that occurred in a previous boot. This mechanism is described in the BERT table. The boot error source is reported as a 'one-time polled' type error source. OSPM queries the boot error source during boot for any existing boot error records. The platform will report the error condition to OSPM via a Common Platform Error Record (CPER) compliant error record. The CPER format is described in the appendices of the UEFI Specification.

The following table describes the format for the Boot Error Record Table (BERT).

Table 18.1: Boot Error Record Table (BERT)

Field	Byte length	Byte offset	Description
Header Signature	4	0	'BERT'. Signature for the Boot Error Record Table.
Length	4	4	Length, in bytes, of BERT.
Revision	1	8	1
Checksum	1	9	Entire table must sum to zero.
OEMID	6	10	OEM ID.
OEM Table ID	8	16	The manufacturer model ID.
OEM Revision	4	24	OEM revision of the BERT for the supplied OEM table ID.
Creator ID	4	28	Vendor ID of the utility that created the table.
Creator Revision	4	32	Revision of the utility that created the table.
Boot Error Region Length	4	36	The length in bytes of the boot error region.
Boot Error Region	8	40	64-bit physical address of the Boot Error Region.

The Boot Error Region is a range of addressable memory that OSPM can access during initialization, to determine if an unhandled error condition occurred. System firmware must report this memory range as firmware reserved. The format of the Boot Error Region follows that of an Error Status Block, as defined in the *Generic Hardware Error Source Structure*. The format of the error status block is described by the *Generic Error Status Block* table.

For details of some of the fields listed in the *Generic Error Data Entry* table, please see the Section Descriptors definitions in the the UEFI Specification appendices, under the description of the Common Platform Error Record.

18.3.2 ACPI Error Source

The hardware error source describes a standardized mechanism platforms may use to describe their error sources. Use of this interface is the preferred way for platforms to describe their error sources as it is platform and processor-architecture independent and allows the platform to describe the operational parameters associated with error sources.

This mechanism allows for the platform to describe error sources in detail; communicating operational parameters (i.e. severity levels, masking bits, and threshold values) to OSPM as necessary. It also allows the platform to report error sources for which OSPM would typically not implement support (for example, chipset-specific error registers).

The Hardware Error Source Table (HEST) provides the platform firmware a way to describe a system's hardware error sources to OSPM. The HEST format is shown in the following table.

Table 18.2: Hardware Error Source Table (HEST)

Field	Byte length	Byte offset	Description
Header Signature	4	0	"HEST". Signature for the Hardware Error Source Table.
Length	4	4	Length, in bytes, of entire HEST. Entire table must be contiguous.
Revision	1	8	2
Checksum	1	9	Entire table must sum to zero.
OEMID	6	10	OEM ID.
OEM Table ID	8	16	The manufacturer model ID.
OEM Revision	4	24	OEM revision of the HEST for the supplied OEM table ID.
Creator ID	4	28	Vendor ID of the utility that created the table.
Creator Revision	4	32	Revision of the utility that created the table.
Error Source Count	4	36	The number of error source descriptors.

continues on next page

Table 18.2 – continued from previous page

Field	Byte length	Byte offset	Description
Error Source Structure[n]	•	40	A series of Error Source Descriptor Entries.

Note: Error source types 3, 4, and 5 are reserved for legacy reasons and must not be used.

Note: Starting with revision 2 of HEST, the Error Source Structures must be sorted in Type ascending order for Error Source Structure Types of less than 12.

Note: Beginning with error source type 12 and onward, each Error Source Structure must use the standard Error Source Structure Header as defined in Section 18.3.2.11.

The following sections detail each of the specific error source descriptors.

18.3.2.1 IA-32 Architecture Machine Check Exception

Processors implementing the IA-32 Instruction Set Architecture employ a machine check exception mechanism to alert OSPM to the presence of an uncorrected hardware error condition. The information in this table is used by OSPM to configure the machine check exception mechanism for each processor in the system.

Only one entry of this type is permitted in the HEST. OSPM applies the information specified in this entry to all processors.

Table 18.3: IA-32 Architecture Machine Check Exception Structure

Field	Byte Length	Byte Offset	Description
Type	2	0	0 - IA-32 Architecture Machine Check Exception Structure.
Source Id	2	2	This value serves to uniquely identify this error source against other error sources reported by the platform.
<i>Reserved</i>	2	4	Reserved.
Flags	1	6	<p>Bit [0] - FIRMWARE_FIRST: If set, this bit indicates to the OSPM that the interrupt handler from system firmware will run first for this error source.</p> <p>Bit [2] - GHES_ASSIST: If set, this bit indicates that although OSPM is responsible for directly handling the error (as expected when FIRMWARE_FIRST is not set), system firmware may report additional information in the context of the error reported by hardware. The additional information is reported in a Generic Hardware Error Source structure with a matching Related Source ID. See Section 18.7, <i>GHES_ASSIST Error Reporting</i>. NOTE: If FIRMWARE_FIRST is set, this bit is reserved.</p> <p>All other bits are reserved.</p>

continues on next page

Table 18.3 – continued from previous page

Field	Byte Length	Byte Offset	Description
Enabled	1	7	Specifies whether MCE is to be enabled. If set to 1, this field indicates this error source is to be enabled. If set to 0, this field indicates that the error source is not to be enabled.
Number of Records To Pre-allocate	4	8	Indicates the number of error records to pre-allocate for this error source.
Max Sections Per Record	4	12	Indicates the maximum number of error sections included in an error record created as a result of an error reported by this error source.
Global Capability Init Data	8	16	Indicates the value of the machine check global capability register.
Global Control Init Data	8	24	Indicates the value to be written to the machine check global control register.
Number Of Hardware Banks	1	32	Indicates the number of hardware error reporting banks.
<i>Reserved</i>	7	33	<i>Reserved.</i>
Machine Check Bank Structure[n]	•	40	A list of Machine Check Bank structures defined in the <i>IA-32 Architecture Machine Check Bank Structure</i>

18.3.2.1.1 IA-32 Architecture Machine Check Bank Structure

This table describes the attributes of a specific IA-32 architecture machine check hardware error bank.

Table 18.4: IA-32 Architecture Machine Check Error Bank Structure

Field	Byte Length	Byte Offset	Description
Bank Number	1	0	Zero-based index identifies the machine check error bank.
Clear Status On Initialization	1	1	If set, indicates the status information in this machine check bank is to be cleared during system initialization as follows: 0 - Clear 1 - Don't clear
Status Data Format	1	2	Identifies the format of the data in the status register: 0 - IA-32 MCA 1 - Intel® 64 MCA 2 - AMD64MCA All other values are reserved
<i>Reserved</i>	1	3	<i>Reserved.</i>
Control Register MSR Address	4	4	Address of the hardware bank's control MSR. Ignored if zero.
Control Init Data	8	8	This is the value the OSPM will program into the machine check bank's control register.
Status Register MSR Address	4	16	Address of the hardware bank's MCI_STAT MSR. Ignored if zero.

continues on next page

Table 18.4 – continued from previous page

Field	Byte Length	Byte Offset	Description
Address Register MSR Address	4	20	Address of the hardware bank's MCI_ADDR MSR. Ignored if zero.
Misc Register MSR Address	4	24	Address of the hardware bank's MCI_MISC MSR. Ignored if zero.

18.3.2.2 IA-32 Architecture Corrected Machine Check

Processors implementing the IA-32 Instruction Set Architecture may report corrected processor errors to OSPM. The information in this table allows platform firmware to communicate key parameters of the corrected processor error reporting mechanism to OSPM, including whether CMC processing should be enabled.

Only one entry of this type is permitted in the HEST. OSPM applies the information specified in this entry to all processors.

Table 18.5: IA-32 Architecture Corrected Machine Check Structure

Field	Byte Length	Byte Offset	Description
Type	2	0	1 - IA-32 Architecture Corrected Machine Check Structure.
Source Id	2	2	Uniquely identifies the error source.
<i>Reserved</i>	2	4	Reserved
Flags	1	6	<p>Bit [0] - FIRMWARE_FIRST: If set, this bit indicates to the OSPM that the interrupt handler from system firmware will run first for this error source.</p> <p>Bit [2] - GHES_ASSIST: If set, this bit indicates that although OSPM is responsible for directly handling the error (as expected when FIRMWARE_FIRST is not set), system firmware may report additional information in the context of the error reported by hardware. The additional information is reported in a Generic Hardware Error Source structure with a matching Related Source ID. See Section 18.7, GHES_ASSIST Error Reporting. NOTE: If FIRMWARE_FIRST is set, this bit is reserved.</p> <p>All other bits must be set to zero.</p>
Enabled	1	7	<p>If the field value is 1, indicates this error source is to be enabled.</p> <p>If the field value is 0, indicates that the error source is not to be enabled.</p> <p>If FIRMWARE_FIRST is set in the flags field, the Enabled field is ignored by OSPM.</p>
Number of Records To Pre-allocate	4	8	Indicates the number of error records to pre-allocate for this error source. Must be >= 1.
Max Sections Per Record	4	12	Indicates the maximum number of error sections included in an error record created as a result of an error reported by this error source. Must be >= 1.

continues on next page

Table 18.5 – continued from previous page

Field	Byte Length	Byte Offset	Description
Notification Structure	28	16	Hardware Error Notification Structure as defined in <i>Hardware Error Notification Structure</i> .
Number Of Hardware Banks	1	44	The number of hardware error reporting banks.
<i>Reserved</i>	3	45	Reserved.
Machine Check Bank Structure[n]	•	48	A list of Machine Check Bank structures defined in <i>IA-32 Architecture Machine Check Bank Structure</i> .

18.3.2.3 IA-32 Architecture Non-Maskable Interrupt

Uncorrected platform errors are typically reported using the Non-Maskable Interrupt (NMI) vector (for example, INT 2). This table allows platform firmware to communicate parameters regarding the configuration and handling of NMI error conditions.

Only one entry of this type is permitted in the HEST.

Table 18.6: IA-32 Architecture NMI Error Structure

Field	Byte Length	Byte Offset	Description
Type	2	0	2 - IA-32 Architecture NMI Structure.
Source Id	2	2	Uniquely identifies this error source.
<i>Reserved</i>	4	4	Must be zero.
Number of Records To Pre-allocate	4	8	Indicates number of error records to pre-allocate for this error source. Must be ≥ 1 .
Max Sections Per Record	4	12	Indicates maximum number of error sections included in an error record created as a result of an error reported by this error source. Must be ≥ 1 .
Max Raw Data Length	4	16	The size in bytes of the NMI error data.

18.3.2.4 PCI Express Root Port AER Structure

PCI Express (PCIe) root ports may implement PCIe Advanced Error Reporting (AER) support. This table contains information platform firmware supplies to OSPM for configuring AER support on a given root port.

The HEST may contain one entry of this type for each PCI Express root port if none of the entries has the GLOBAL flag set. If the GLOBAL flag is set, there may only be one entry of this type and the information contained in that entry is applied to all PCIe root ports.

Table 18.7: PCI Express Root Port AER Structure

Field	Byte Length	Byte Offset	Description
Type	2	0	6 - AER Root Port.
Source Id	2	2	Uniquely identifies the error source.
<i>Reserved</i>	2	4	Reserved.

continues on next page

Table 18.7 – continued from previous page

Field	Byte Length	Byte Offset	Description
Flags	1	6	<p>Bit [0] - FIRMWARE_FIRST: If set, this bit indicates to the OSPM that the interrupt handler from system firmware will run first for this error source. This flag does not grant nor deny access to AER registers. OSPM should evaluate _OSC for PCI hierarchies to determine AER register ownership.</p> <p>Bit [1] - GLOBAL: If set, indicates that the settings contained in this structure apply globally to all PCI Express Devices.</p> <p>All other bits must be set to zero.</p>
Enabled	1	7	If the field value is 1, indicates this error source is to be enabled. If the field value is 0, indicates that the error source is not to be enabled. If FIRMWARE_FIRST is set in the flags field, the Enabled field is ignored by the OSPM.
Number of Records To Pre-allocate	4	8	Indicates the number error records to pre-allocate for this error source. Must be >= 1.
Max Sections Per Record	4	12	Indicates the maximum number of error sections included in an error record created as a result of an error reported by this error source. Must be >= 1.
Bus	4	16	<p>Identifies the PCI Bus and Segment of the root port.</p> <p>The Bus is encoded in bits [7:0].</p> <p>For systems that expose multiple PCI segment groups, the segment number is encoded in bits [23:8], and bits [31-24] must be zero.</p> <p>For systems that do not expose multiple PCI segment groups, bits [31:8] must be zero.</p> <p>If the GLOBAL flag is specified, this field is ignored.</p>
Device	2	20	Identifies the PCI Device Number of the root port. If the GLOBAL flag is specified, this field is ignored.
Function	2	22	Identifies the PCI Function number of the root port. If the GLOBAL flag is specified, this field is ignored.
Device Control	2	24	Device control bits with which to initialize the device.
<i>Reserved</i>	2	26	Must be zero.
Uncorrectable Error Mask	4	28	Value to write to the root port's Uncorrectable Error Mask register.
Uncorrectable Error Severity	4	32	Value to write to the root port's Uncorrectable Error Severity register.
Correctable Error Mask	4	36	Value to write to the root port's Correctable Error Mask register.
Advanced Error Capabilities and Control	4	40	Value to write to the root port's Advanced Error Capabilities and Control Register.
Root Error Command	4	44	Value to write to the root port's Root Error Command Register.

Note: For PCI Express Advanced Error Reporting (AER) resources, ownership and control of AER registers are determined by the evaluation of the PCI_OSC() method as described in the most current revision of the PCI Firmware Specification. The FIRMWARE_FIRST bit in the Flags Field does not serve to grant, nor deny, access to the AER registers within the PCI Express device(s) that are described by the structure.

18.3.2.5 PCI Express Device AER Structure

PCI Express devices may implement AER support. This table contains information platform firmware supplies to OSPM for configuring AER support on a given PCI Express device.

The HEST may contain one entry of this type for each PCI Express endpoint device if none of the entries has the GLOBAL flag set. If the GLOBAL flag is set, there may only be one entry of this type and the information contained in that entry will be applied to all PCI Express endpoint devices.

Table 18.8: PCI Express Device AER Structure

Field	Byte Length	Byte Offset	Description
Type	2	0	7 - AER Endpoint.
Source Id	2	2	Uniquely identifies the error source.
<i>Reserved</i>	2	4	Reserved.
Flags	1	6	<p>Bit [0] - FIRMWARE_FIRST: If set, this bit indicates to the OSPM that the interrupt handler from system firmware will run first for this error source. This flag does not grant nor deny access to AER registers. OSPM should evaluate _OSC for PCI hierarchies to determine AER register ownership.</p> <p>Bit [1] - GLOBAL: If set, indicates that the settings contained in this structure apply globally to all PCI Express Devices.</p> <p>All other bits must be set to zero.</p>
Enabled	1	7	<p>If the field value is 1, indicates this error source is to be enabled.</p> <p>If the field value is 0, indicates that the error source is not to be enabled.</p> <p>If FIRMWARE_FIRST is set in the flags field, the Enabled field is ignored by the OSPM.</p>
Number of Records To Pre-allocate	4	8	Indicates the number of error records to pre-allocate for this error source. Must be >= 1.
Max Sections Per Record	4	12	Indicates the maximum number of error sections included in an error record created as a result of an error reported by this error source. Must be >= 1.

continues on next page

Table 18.8 – continued from previous page

Field	Byte Length	Byte Offset	Description
Bus	4	16	Identifies the PCI Bus and Segment of the device. The Bus is encoded in bits [7:0]. For systems that expose multiple PCI segment groups, the segment number is encoded in bits [23:8], and bits [31:24] must be zero. For systems that do not expose multiple PCI segment groups, bits 8-31 must be zero. If the GLOBAL flag is specified, this field is ignored.
Device	2	20	Identifies the PCI Device Number of the device. If the GLOBAL flag is specified, this field is ignored.
Function	2	22	Identifies the PCI Function Number of the device. If the GLOBAL flag is specified, this field is ignored.
Device Control	2	24	Device control bits with which to initialize the device.
<i>Reserved</i>	2	26	Must be zero.
Uncorrectable Error Mask	4	28	Value to write to the root port's Uncorrectable Error Mask register.
Uncorrectable Error Severity	4	32	Value to write to the root port's Uncorrectable Error Severity register.
Correctable Error Mask	4	36	Value to write to the root port's Correctable Error Mask register.
Advanced Error Capabilities and Control	4	40	Value to write to the root port's Advanced Error Capabilities and Control Register.

Note: For PCI Express Advanced Error Reporting (AER) resources, ownership and control of AER registers are determined by the evaluation of the PCI_OSC() method as described in the most current revision of the PCI Firmware Specification. The FIRMWARE_FIRST bit in the Flags Field does not serve to grant, nor deny, access to the AER registers within the PCI Express device(s) that are described by the structure.

18.3.2.6 PCI Express/PCI-X Bridge AER Structure

PCI Express/PCI-X bridges that implement AER support implement fields that control the behavior how errors are reported across the bridge.

The HEST may contain one entry of this type for each PCI Express/PCI-X bridges if none of the entries has the GLOBAL flag set. If the GLOBAL flag is set, there may only be one entry of this type and the information contained in that entry will be applied to all PCI Express/ PCI-X bridges.

Table 18.9: PCI Express/PCI-X Bridge AER Structure

Field	Byte Length	Byte Offset	Description
Type	2	0	8 - AER Bridge.
Source Id	2	2	Uniquely identifies the error source.

continues on next page

Table 18.9 – continued from previous page

Field	Byte Length	Byte Offset	Description
<i>Reserved</i>	2	4	Reserved.
Flags	1	6	<p>Bit [0] - FIRMWARE_FIRST: If set, this bit indicates to the OSPM that the interrupt handler from system firmware will run first for this error source. This flag does not grant nor deny access to AER registers. OSPM should evaluate _OSC for PCI hierarchies to determine AER register ownership.</p> <p>Bit [1] - GLOBAL: If set, indicates that the settings contained in this structure apply globally to all PCI Express Devices.</p> <p>All other bits must be set to zero.</p>
Enabled	1	7	<p>If the field value is 1, indicates this error source is to be enabled.</p> <p>If the field value is 0, indicates that the error source is not to be enabled.</p> <p>If FIRMWARE_FIRST is set in the flags field, the Enabled field is ignored by the OSPM.</p>
Number of Records To Pre-allocate	4	8	Indicates the number of error records to pre-allocate for this error source. Must be >= 1.
Max Sections Per Record	4	12	Indicates the maximum number of error sections included in an error record created as a result of an error reported by this error source. Must be >= 1.
Bus	4	16	<p>Identifies the PCI Bus and Segment of the bridge.</p> <p>The Bus is encoded in bits [7:0].</p> <p>For systems that expose multiple PCI segment groups, the segment number is encoded in bits [23:8], and bits [31:24] must be zero.</p> <p>For systems that do not expose multiple PCI segment groups, bits 8-31 must be zero. If the GLOBAL flag is specified, this field is ignored.</p>
Device	2	20	Identifies the PCI device number of the bridge. If the GLOBAL flag is specified, this field is ignored.
Function	2	22	Identifies the PCI function number of the bridge. If the GLOBAL flag is specified, this field is ignored.
Device Control	2	24	Device control bits with which to initialize the device.
<i>Reserved</i>	2	26	This value must be zero.
Uncorrectable Error Mask	4	28	Value to write to the bridge's Uncorrectable Error Mask register.
Uncorrectable Error Severity	4	32	Value to write to the bridge's Uncorrectable Error Severity register.
Correctable Error Mask	4	36	Value to write to the bridge's Correctable Error Mask register.
Advanced Error Capabilities and Control	4	40	Value to write to the bridge's Advanced Error Capabilities and Control Register.

continues on next page

Table 18.9 – continued from previous page

Field	Byte Length	Byte Offset	Description
Secondary Uncorrectable Error Mask	4	44	Value to write to the bridge's secondary uncorrectable error mask register.
Secondary Uncorrectable Error Severity	4	48	Value to write to the bridge's secondary uncorrectable error severity register.
Secondary Advanced Capabilities and Control	4	52	Value to write to the bridge's secondary advanced capabilities and control register.

Note: For PCI Express Advanced Error Reporting (AER) resources, ownership and control of AER registers are determined by the evaluation of the PCI_OSC() method as described in the most current revision of the PCI Firmware Specification. The FIRMWARE_FIRST bit in the Flags Field does not serve to grant, nor deny, access to the AER registers within the PCI Express device(s) that are described by the structure.

18.3.2.7 Generic Hardware Error Source

The platform may describe a generic hardware error source to OSPM using the Generic Hardware Error Source structure. A generic hardware error source is an error source that either notifies OSPM of the presence of an error using a non-standard notification mechanism or reports error information that is encoded in a non-standard format.

Using the information in a Generic Hardware Error Source structure, OSPM configures an error handler to read the error data from an error status block - a memory range set aside by the platform for recording error status information.

As the generic hardware error source is non-standard, OSPM does not implement built-in support for configuration and control operations. The error source must be configured by system firmware during boot.

Some platforms may describe multiple Generic Hardware Error Source structures with different notification types, as defined in Table 18.10. For example, a platform may describe one error source for the handling of synchronous errors (e.g. MCE or SEA), and a second source for handling asynchronous errors (e.g. SCI or External Interrupt).

Table 18.10: Generic Hardware Error Source Structure

Field	Byte Length	Byte Offset	Description
Type	2	0	9 - Generic Hardware Error Source Structure.
Source Id	2	2	Uniquely identify the error source.
Related Source ID	2	4	<p>This field represents the Source ID of an alternate error source for which the platform:</p> <ul style="list-style-type: none"> (a) Requires Firmware-First handling (FIRMWARE_FIRST flag is set on alternate error source). See Section 18.4. (b) Provides additional information in the context of an error reported by hardware (GHES_ASSIST flag is set on alternate error source). See Section 18.7. <p>If this generic error source does not represent an alternate source, this field must be set to 0xFFFF.</p>

continues on next page

Table 18.10 – continued from previous page

Field	Byte Length	Byte Offset	Description
Flags	1	6	Reserved.
Enabled	1	7	If the field value is 1, indicates this error source is to be enabled. If the field value is 0, indicates that the error source is not to be enabled.
Number of Records To Pre-allocate	4	8	Indicates the number of error records to pre-allocate for this error source. Must be ≥ 1 .
Max Sections Per Record	4	12	Indicates the maximum number of error sections included in an error record created as a result of an error reported by this error source. Must be ≥ 1 .
Max Raw Data Length	4	16	Indicates the size in bytes of the error data recorded by this error source.
Error Status Address	12	20	Generic Address Structure as defined in Section 5.2.3.2. This field specifies the location of a register that contains the physical address of a block of memory that holds the error status data for this error source. This memory range must reside in firmware reserved memory. OSPM maps this range into system address space and reads the error status information from the mapped address.
Notification Structure	28	32	Hardware Error Notification Structure as defined in Table 18.14. This structure specifies how this error source notifies OSPM that an error has occurred.
Error Status Block Length	4	60	Identifies the length in bytes of the error status data block.

The Error Status Address field specifies the location of an 8-byte memory-mapped register that holds the physical address of the error status block. This error status block must reside in a memory range reported to OSPM as firmware reserved. OSPM maps the error status buffer into system address space in order to read the error data.

18.3.2.7.1 Generic Error Data

The Error Status Block contains the error status information for a given generic error source. OSPM provides an error handler that formats one or more of these blocks as necessary for the specific operating system.

The generic error status block includes two levels of information. The top level is a Generic Error Status Block structure as defined in the following table. The next level is one or more *Generic Error Data Entry* structures, defined in the second table below.

Table 18.11: Generic Error Status Block

Field	Byte Length	Byte Offset	Description
Block Status	4	0	Indicates the type of error information reported in the error packet: Bit [0] - Uncorrectable Error Valid: If set to one, indicates that an uncorrectable error condition exists. Bit [1] - Correctable Error Valid: If set to one, indicates that a correctable error condition exists. Bit [2] - Multiple Uncorrectable Errors: If set to one, indicates that more than one uncorrectable errors have been detected. Bit [3] - Multiple Correctable Errors: If set to one, indicates that more than one correctable error has been detected. Bits [13:4] - Error Data Entry Count: This value indicates the number of Error Data Entries found in the Data section. Bits [31:14] - <i>Reserved</i>
Raw Data Offset	4	4	Offset in bytes from the beginning of the Error Status Block to raw error data. The raw data must follow any Generic Error Data Entries.
Raw Data Length	4	8	Length in bytes of the raw data.
Data Length	4	12	Length in bytes of the generic error data.
Error Severity	4	16	Identifies the error severity of the reported error:: 0 - Recoverable 1 - Fatal 2 - Corrected 3 - None. Note: This is the error severity of the entire event. Each Generic Error Data Entry also includes its own Error Severity field.
Generic Error Data Entries	Data Length	20	The information contained in this field is a collection of zero or more <i>Generic Error Data Entries</i> .

One or more Generic Error Data Entry structures may be recorded in the Generic Error Data Entries field of the Generic Error Status Block structure. This allows the platform to accumulate information for multiple hardware components related to a given error event. For example, if the generic error source represents an error that occurs on a device on the secondary side of a PCI Express / PCI-X Bridge, it is useful to record error information from the PCI Express Bridge and from the PCI-X device. Utilizing two Generic Error Data Entry structures enables this - see [Table 18.12](#) below.

For more details of the fields described in the following table, see the definition of Section Descriptors in the UEFI Specification appendix for the Common Platform Error Record.

Table 18.12: Generic Error Data Entry

Field	Byte Length	Byte Offset	Description
Section Type	16	0	Identifies the type of error data in this entry. See the Section Type field of the Section Descriptor in the <i>UEFI Specification</i> .
Error Severity	4	16	Identifies the severity of the reported error. 0 - Recoverable 1 - Fatal 2 - Corrected 3 - None
Revision	2	20	The revision number is 0x300. See the Revision field of the Section Descriptor in the <i>UEFI Specification</i> .

continues on next page

Table 18.12 – continued from previous page

Field	Byte Length	Byte Offset	Description
Validation Bits	1	22	Identifies whether certain fields are populated with valid data. This field indicates the validity of the following fields: Bit 0 - If 1, the FRUID field contains valid information. Bit 1 - If 1, the FRUString FRU Text field contains valid information. Bit 2 - If 1, the TimeStamp field contains valid information. Bit 7:3 - Reserved, must be zero..
Flags	1	23	Flags describing the error data. See the Flags field of the Section Descriptor in the <i>UEFI Specification</i> appendix titled “ <i>Common Platform Error Record</i> ” .
Error Data Length	4	24	Length in bytes of the generic error data. It is valid to have a Data Length of zero. This would be used for instance in firmware-first error handling where the platform reports errors to the OSPM using NMI.
FRU Id	16	28	Identifies the Field Replaceable Unit. See the FRU Id field of the Section Descriptor in the <i>UEFI Specification</i> appendix titled “ <i>Common Platform Error Record</i> ”.
FRU Text	20	44	Text field describing the Field Replaceable Unit. See the FRU Text field of the Section Descriptor in the <i>UEFI Specification</i> appendix titled “ <i>Common Platform Error Record</i> ”.
Timestamp	8	64	If marked valid per the validation bits field, this field correlates to the time when the error information was collected by the system software and may not necessarily represent the time of the error event. The timestamp contains the local time in BCD format. See the Timestamp field of the Error Record Header section in the <i>EFI Specification</i> appendix titled “ <i>Common Platform Error Record</i> ”.
Data	Error Data Length	64	Generic error data. The information contained in this field must match one of the error record section types defined in the <i>UEFI Specification</i> appendix, “ <i>Common Platform Error Record</i> ”.

18.3.2.7.2 Event Notification For Generic Error Sources

An event notification is recommended for corrected errors where latency in processing error reports is not critical to proper system operation. The implementation of Event notification requires the platform to define a device with PNP ID PNP0C33 in the ACPI namespace, referred to as the error device. This device is used to notify the OSPM that a generic error source is reporting an error. Since multiple generic error sources can use event notification, it is the responsibility of the OSPM to scan the list of these generic error sources and check the block status field (*Generic Error Status Block*) to identify the source that reported the error.

The platform is responsible for providing a control method that issues a NOTIFY on the error device (PNP0C33), with a notification code of type 0x80.

For traditional ACPI platforms the event signaling follows the model described in *Queuing the matching control method for execution*. The platform implements a general purpose event (GPE) for the error notification, and the GPE has an associated control method.

An example of a GPE control method for error notification is the following:

```
Method (\_GPE._L08) { // GPE 8 level error notification
    Notify (error_device, 0x80)
```

(continues on next page)

(continued from previous page)

}

For HW-reduced ACPI platforms, the event signaling follows the model described in *GPIO-signaled ACPI Events* and *Interrupt-signaled ACPI events*. The platform implements a notification of error events via interrupts or a GPIO pin. In both cases these are associated with an `_EVT` control method.

An example of an `_EVT` control method for GPIO-based error notification is the following:

```
Method (\_EVT) { // GPIO pin 300 error notification
    Switch (Arg1) {
        Case (300) {
            Notify (error_device, 0x80)
        }
    }
}
```

The overall flow when the platform uses the event notification is:

- The platform enumerates the error source with event as the notification method using the format in the *Generic Hardware Error Source Structure* and the *Generic Error Status Block*.
- The platform surfaces an error device, PNP ID PNP0C33, to the OSPM
- When the platform is ready to report an error, the platform populates the error status block including the block status field (*Generic Error Status Block*).

Traditional ACPI platforms signal the error using an SCI, on the appropriate GPE:

- The OSPM evaluates the GPE control method associated with this event as indicated on *Queuing the matching control method for execution*
- OSPM responds to this notification by checking the error status block of all generic error sources with the SCI Generic notification type to identify the source reporting the error

HW-reduced ACPI platforms signal the error using a GPIO interrupt or another interrupt declared under a generic event device (*Interrupt-signaled ACPI events*). In the case of GPIO-signaled events, an `_AEI` object lists the appropriate GPIO pin, while for Interrupt-signaled events a `_CRS` object is used to list the interrupt:

- The OSPM evaluates the control method associated with this event as indicated in *The Event Method for Handling GPIO Signaled Events* and *The Event Method for Handling Interrupt Signaled Events*.
- OSPM responds to this notification by checking the error status block of all generic error sources with the GPIO-Signal notification or Interrupt-signaled notification types to identify the source reporting the error.

18.3.2.8 Generic Hardware Error Source version 2 (GHESv2 - Type 10)

This is an extension to the Generic Hardware Error source structure (Section 18.3.2.7) for hardware-reduced platforms that rely on RAS controllers for generation of generic error records. A RAS controller may be a hardware or firmware entity that may execute in parallel with OS execution (e.g., a RAS controller may be firmware running on an independent microcontroller, or it could be in the form of platform firmware that runs on one of the application processors). Platforms with RAS controllers must prevent concurrent accesses to the Error Status Block (i.e., the RAS controller must not overwrite the Error Status Block before the OS has completed reading it). The table below provides a high-level example of how the RAS controller might interact with the OS.

For GHESv2 error sources, the OSPM must acknowledge the consumption of the Error Status Block by writing to the “Read Ack Register” listed in the GHESv2 structure (described in the following table). For platforms that describe multiple Generic Hardware Error Sources, the platform must provide a unique memory region for the Error Status Block of each error source.

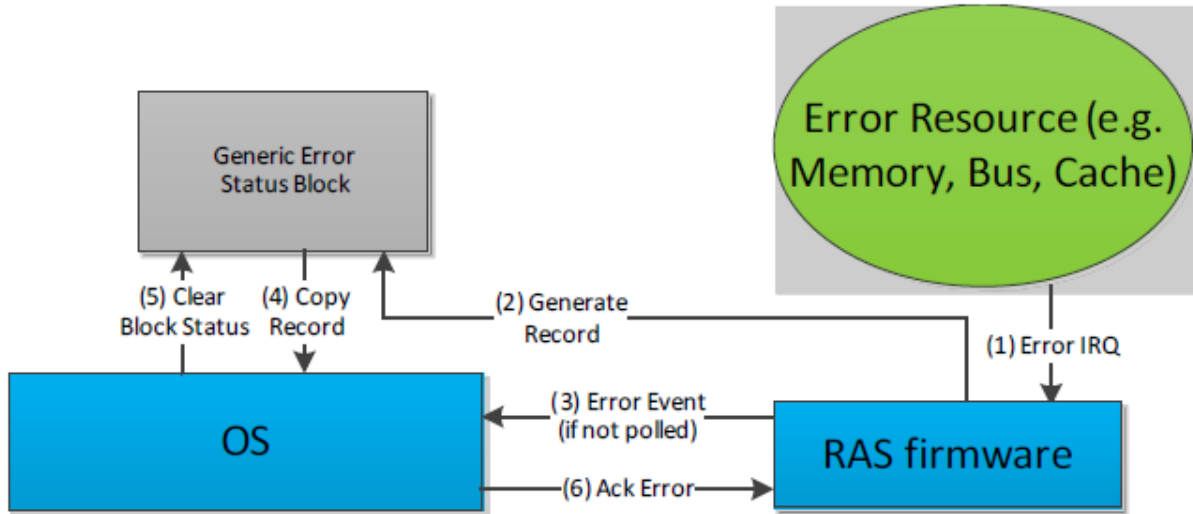

Fig. 18.1: APEI error flow example with external RAS controller

Table 18.13: Generic Hardware Error Source version 2 (GHESv2) Structure

Name	Byte Length	Byte Offset	Description
Type	2	0	10 - Generic Hardware Error Source (version 2) structure
Equivalent fields in Table 18.10	62	2	Same format as fields in Table 18.10, starting from Source Id and ending in Error Status Block Length (inclusive).
Read Ack Register	12	64	Generic Address Structure as defined in Table 18.10. This field specifies the location of the Read Ack Register used to notify the RAS controller that OSPM has processed the Error Status Block. The OSPM writes the bit(s) specified in Read Ack Write, while preserving the bit(s) specified in Read Ack Preserve.
Read Ack Preserve	8	76	Contains a mask of bits to preserve when writing the Read Ack register.
Read Ack Write	8	84	Contains a mask of bits to set when writing the Read Ack register.

These are the steps the OS must take once detecting an error from a particular GHESv2 error source:

- OSPM detects error (via interrupt/exception or polling the block status)
- OSPM copies the error status block
- OSPM clears the block status field of the error status block
- OSPM acknowledges the error via Read Ack register. For example:
 - OSPM reads the Read Ack register → X
 - OSPM writes → ((X & ReadAckPreserve) | ReadAckWrite)

18.3.2.9 Hardware Error Notification

This table describes the notification mechanism associated with a hardware error source.

Table 18.14: Hardware Error Notification Structure

Field	Byte Length	Byte Offset	Description
Type	1	0	Identifies the notification type: 0 - Polled 1 - External Interrupt 2 - Local Interrupt 3 - SCI 4 - NMI 5 - CMCI 6 - MCE 7 - GPIO-Signal 8 - ARMv8 SEA 9 - ARMv8 SEI 10 - External Interrupt - GSIV 11 - Software Delegated Exception. For definitions of the fields in this structure for this type, see Links to ACPI-Related Documents (http://uefi.org/acpi) under the heading, “SDEI Specification.” All other values are reserved
Length	1	1	Total length of the structure in bytes.
Configuration Write Enable	2	2	This field indicates whether configuration parameters may be modified by OSPM. If the bit for the associated parameter is set, the parameter is writeable by OSPM: Bit [0]: Type Bit [1]: Poll Interval Bit [2]: Switch To Polling Threshold Value Bit [3]: Switch To Polling Threshold Window Bit [4]: Error Threshold Value Bit [5]: Error Threshold Window All other bits are reserved.
Poll Interval	4	4	Indicates the poll interval in milliseconds OSPM should use to periodically check the error source for the presence of an error condition.
Vector	4	8	Interrupt vector. For type 10 “External Interrupt - GSIV”, this field specifies the GSIV triggered by the error source. For type 11 “Software Delegated Exception,” this field specifies the SDEI event number (see the SDEI Specification).
Switch To Polling Threshold Value	4	12	The number of error interrupts that must occur within Switch To Polling Threshold Interval before OSPM switches the error source to polled mode.

continues on next page

Table 18.14 – continued from previous page

Switch To Polling Threshold Window	4	16	Indicates the time interval in milliseconds that Switch To Polling Threshold Value interrupts must occur within before OSPM switches the error source to polled mode.
Error Threshold Value	4	20	Indicates the number of error events that must occur within Error Threshold Interval before OSPM processes the event as an error condition.
Error Threshold Window	4	24	Indicates the time interval in milliseconds that Error Threshold Value errors must occur within before OSPM processes the event as an error condition.

18.3.2.10 IA-32 Architecture Deferred Machine Check

Processors implementing the IA-32 Instruction Set Architecture may report Deferred errors to OSPM. These errors indicate that data has been corrupted but not consumed. The information in this table allows platform firmware to communicate key parameters of the deferred processor error reporting mechanism to OSPM, including whether Deferred Machine Check (DMC) processing should be enabled.

Only one entry of this type is permitted in the HEST. OSPM applies the information specified in this entry to all processors.

Table 18.15: IA-32 Architecture Deferred Machine Check Structure

Field	Byte Length	Byte Offset	Description
Type	2	0	11 - IA-32 Architecture Deferred Machine Check Structure.
Source Id	2	2	This value serves to uniquely identify this error source against other error sources reported by the platform.
Reserved	2	4	Reserved.
Flags	1	6	<p>Bit [0] - FIRMWARE_FIRST: If set, this bit indicates to the OSPM that the interrupt handler from system firmware will run first for this error source.</p> <p>Bit [2] - GHES_ASSIST: If set, this bit indicates that although OSPM is responsible for directly handling the error (as expected when FIRMWARE_FIRST is not set), system firmware may report additional information in the context of the error reported by hardware. The additional information is reported in a Generic Hardware Error Source structure with a matching Related Source ID. See Section 18.7, GHES_ASSIST Error Reporting. NOTE: If FIRMWARE_FIRST is set, this bit is reserved.</p> <p>All other bits must be set to zero.</p>
Enabled	1	7	<p>If the field value is 1, indicates this error source is to be enabled.</p> <p>If the field value is 0, indicates that the error source is not to be enabled.</p> <p>If FIRMWARE_FIRST is set in the flags field, the Enabled field is ignored by OSPM.</p>

continues on next page

Table 18.15 – continued from previous page

Field	Byte Length	Byte Offset	Description
Number of Records To Pre-allocate	4	8	Indicates the number of error records to pre-allocate for this error source. Must be ≥ 1 .
Max Sections Per Record	4	12	Indicates the maximum number of error sections included in an error record created as a result of an error reported by this error source. Must be ≥ 1 .
Notification Structure	28	16	Hardware Error Notification Structure, as defined in Table 18.14 .
Number Of Hardware Banks	1	44	Indicates the number of hardware error reporting banks.
Reserved	3	45	Reserved.
Machine Check Bank Structure[n]	•	48	A list of Machine Check Bank structures defined in <i>IA-32 Architecture Machine Check Bank Structure</i> .

18.3.2.11 Error Source Structure Header (Type 12 Onward)

Beginning with error source type 12 and onward, each Error Source Structure must use the standard Error Source Structure Header as defined below.

Table 18.16: Error Source Structure Header (Type 12 and Onward)

Field	Byte Length	Byte Offset	Description
Type	2	0	Error Type
Error Source Structure Length	2	2	The length of the error source structure in bytes

18.4 Firmware First Error Handling

It may be necessary for the platform to process certain classes of errors in firmware before relinquishing control to OSPM for further error handling. Errata management and error containment are two examples where firmware-first error handling is beneficial. Generic hardware error sources support this model through the related source ID.

The platform reports the original error source to OSPM via the hardware error source table (HEST) and sets the FIRMWAREFIRST flag for this error source. In addition, the platform must report a generic error source with a related source ID set to the original source ID. This generic error source is used to notify OSPM of the errors on the original source and their status after the firmware first handling.

There are different notification strategies that can be used in firmware first handling; the following options are available to the platform:

- Traditional ACPI platforms may use NMI to notify the OSPM of both corrected and uncorrected errors for a given error source
- Traditional ACPI platforms may use NMI to report uncorrected errors and the SCI to report corrected errors
- Traditional ACPI platforms may use NMI to report uncorrected errors and polling to notify the OSPM of corrected errors
- HW-reduced ACPI platforms may use GPIO-signaled events, Interrupt-signaled events, or polling to report corrected errors.

18.4.1 Example: Firmware First Handling Using NMI Notification

If the platform chooses to use NMI to report errors, which is the recommended method for uncorrected errors, the platform follows these steps:

1. System firmware configures the platform to trigger a firmware handler when the error occurs
2. System firmware identifies the error source for which it will handle errors via the error source enumeration interface by setting the `FIRMWARE_FIRST` flag
3. System firmware describes the generic error source, and the associated error status block, as described in *Generic Hardware Error Source*. System firmware identifies the relation between the generic error source and the original error source by using the original source ID in the related source ID of *Generic Hardware Error Source Structure*.
4. When a hardware error reported by the error source occurs, system firmware gains control and handles the error condition as required. Upon completion system firmware should do the following:
5. Extract the error information from the error source and fill in the error information in the data block of the generic error source it identified as an alternate in step 3. The error information format follows the specification in *Generic Error Data*
6. Set the appropriate bit in the block status field (*Generic Error Status Block*) to indicate to the OSPM that a valid error condition is present.
7. Clears error state from the hardware.
8. Generates an NMI.

At this point, the OSPM NMI handler scans the list of generic error sources to find the error source that reported the error and processes the error report

18.5 Error Serialization

- The error record serialization feature is used to save and retrieve hardware error information to and from a persistent store. OSPM interacts with the platform through a platform interface. If the *Error Record Serialization Table (ERST)* is present, OSPM uses the ACPI solution described below. Otherwise, OSPM uses the UEFI runtime variable services to carry out error record persistence operations on UEFI based platforms.
- For error persistence across boots, the platform must implement some form of non-volatile store to save error records. The amount of space required depends on the platform's processor architecture. Typically, this store will be flash memory or some other form of non-volatile RAM.
- Serialized errors are encoded according to the Common Platform Error Record (CPER) format, which is described in the appendices of the UEFI Specification. These entries are referred to as error records.
- The Error Record Serialization Interface is designed to be sufficiently abstract to allow hardware vendors flexibility in how they implement their error record serialization hardware. The platform provides details necessary to communicate with its serialization hardware by populating the ERST with a set of Serialization Instruction Entries. One or more serialization instruction entries comprise a Serialization Action. OSPM carries out serialization operations by executing a series of Serialization Actions. Serialization Actions and Serialization Instructions are described in detail in the following sections.

The following table details the ERST layout, which system firmware is responsible for building.

Table 18.17: Error Record Serialization Table (ERST)

Field	Byte Length	Byte Offset	Description
ACPI Standard Header			
Header Signature	4	0	“ERST”. Signature for the Error Record Serialization Table.
Length	4	4	Length, in bytes, of entire ERST. Entire table must be contiguous.
Revision	1	8	1
Checksum	1	9	Entire table must sum to zero.
OEMID	6	10	OEM ID.
OEM Table ID	8	16	The manufacturer model ID.
OEM Revision	4	24	OEM revision of the ERST for the supplied OEM table ID.
Creator ID	4	28	Vendor ID of the utility that created the table.
Creator Revision	4	32	Revision of the utility that created the table.
Serialization Header			
Serialization Header Size	4	36	Length in bytes of the serialization header.
<i>Reserved</i>	4	40	Must be zero.
Instruction Entry Count	4	44	The number of Serialization Instruction Entries in the-Serialization Action Table.
Serialization Action Table			
Serialization Instruction Entries		48	A series of error logging instruction entries.

18.5.1 Serialization Action Table

A Serialization Action is defined as a series of Serialization Instructions on registers that result in a well known action. A Serialization Instruction is a Serialization Action primitive and consists of either reading or writing an abstracted hardware register. The Serialization Action Table contains Serialization Instruction Entries for all the Serialization Actions the platform supports.

In most cases, a Serialization Action comprises only one Serialization Instruction, but it is conceivable that a more complex device will require more than one Serialization Instruction. When an action does comprise more than one instruction, the instructions must be listed consecutively and they will consequently be performed sequentially, according to their placement in the Serialization Action Table.

18.5.1.1 Serialization Actions

This section identifies the Serialization Actions that comprise the Error Record Serialization interface, as shown in the following table.

Table 18.18: Error Record Serialization Actions

Value	Name	Description
0x0	BEGIN_WRITE_OPERATION	Indicates to the platform that an error record write operation is beginning. This allows the platform to set its operational context.
0x1	BEGIN_READ_OPERATION	Indicates to the platform that an error record read operation is beginning. This allows the platform to set its operational context.

continues on next page

Table 18.18 – continued from previous page

Value	Name	Description
0x2	BEGIN_CLEAR_OPERATION	Indicates to the platform that an error record clear operation is beginning. This allows the platform to set its operation context.
0x3	END_OPERATION	Indicates to the platform that the current error record operation has ended. This allows the platform to clear its operational context.
0x4	SET_RECORD_OFFSET	Sets the offset from the base of the Error Log to transfer an error record.
0x5	EXECUTE_OPERATION	Instructs the platform to carry out the current operation based on the current operational context.
0x6	CHECK_BUSY_STATUS	Returns the state of the current operation. Once an operation has been executed through the EXECUTE_OPERATION action, the platform is required to return an indication that the operation is in progress until the operation completes. This allows the OS to poll for completion by repeatedly executing the CHECK_BUSY_STATUS action until the platform indicates that the operation not busy.
0x7	GET_COMMAND_STATUS	Returns the status of the current operation. The platform is expected to maintain a status code for each operation. Bits [8:1] of the value returned from the Register Region indicate the command status, which requires that the Bit Offset of the GAS for the Register Region is set to 1. See <i>Command-Status-Definition</i> for a list of valid command status codes.
0x8	GET_RECORD_IDENTIFIER	Returns the record identifier of an existing error record on the persistent store. The error record identifier is a 64-bit unsigned value as defined in the appendices of the UEFI Specification. If the record store is empty, this action must return 0xFFFFFFFFFFFFFFFF.
0x9	SET_RECORD_IDENTIFIER	Sets the record identifier. The error record identifier is a 64-bit unsigned value as defined in the appendices of the UEFI Specification.
0xA	GET_RECORD_COUNT	Retrieves the number of error records currently stored on the platforms persistent store. The platform is expected to maintain a count of the number of error records resident in its persistent store.
0xB	BEGIN_DUMMY_WRITE- _OPERATION	Indicates to the platform that a dummy error record write operation is beginning. This allows the platform to set its operational context. A dummy error record write operation performs no actual transfer of information from the Error Log Address Range to the persistent store.
0xC	RESERVED	Reserved.
0xD	GET_ERROR_LOG- _ADDRESS_RANGE	Returns the 64-bit physical address OSPM uses as the buffer for reading/writing error records.
0xE	GET_ERROR_LOG- _ADDRESS_RANGE_LENGTH	Returns the length in bytes of the Error Log Address Range

continues on next page

Table 18.18 – continued from previous page

Value	Name	Description
0xF	GET_ERROR_LOG- _ADDRESS_RANGE_ATTRIBUTES	Returns attributes that describe the behavior of the error log address range: Bit [0] (0x1) - Reserved. Bit [1] (0x2) - Non-Volatile: Indicates that the error log address range is in non-volatile RAM. Bit [2] (0x4) - Slow: Indicates that the memory in which the error log address range is located has slow access times. All other bits reserved.
0x10	GET_EXECUTE- _OPERATION_TIMINGS	Returns an encoded QWORD: [63:32] value in microseconds that the platform expects would be the maximum amount of time it will take to process and complete an EXECUTE_OPERATION. [31:0] value in microseconds that the platform expects would be the nominal amount of time it will take to process and complete an EXECUTE_OPERATION.

The following table defines the serialization action status codes returned from GET_COMMAND_STATUS.

Table 18.19: Command Status Definition

Value	Description
0x00	Success
0x01	Not Enough Space
0x02	Hardware Not Available
0x03	Failed
0x04	Record Store Empty
0x05	Record Not Found

18.5.1.2 Serialization Instruction Entries

Each Serialization Action consists of a series of one or more Serialization Instructions. A Serialization Instruction represents a primitive operation on an abstracted hardware register represented by the register region as defined in a Serialization Instruction Entry.

A Serialization Instruction Entry describes a region in a serialization hardware register and the serialization instruction to be performed on that region. The following table details the layout of a Serialization Instruction Entry.

Table 18.20: Serialization Instruction Entry

Field	Byte Length	Byte Offset	Description
Serialization Action	1	N+0	The serialization action that this serialization instruction is a part of.
Instruction	1	N+1	Identifies the instruction to execute. See the <i>Serialization Instructions table</i> for a list of valid serialization instructions.
Flags	1	N+2	Flags that qualify the instruction.

continues on next page

Table 18.20 – continued from previous page

Field	Byte Length	Byte Offset	Description
<i>Reserved</i>	1	N+3	Must be zero.
Register Region	12	N+4	Generic Address Structure as defined in Section 5.2.3.2 to describe the address and bit.
Value	8	N+16	Value used with READ_REGISTER_VALUE and WRITE_REGISTER_VALUE instructions.
Mask	8	N+24	The bit mask required to obtain the bits corresponding to the serialization instruction in a given bit range defined by the register region.

Register Region is described as a generic address structure. This structure describes the physical address of a register as well as the bit range that corresponds to a desired region of the register. The bit range is defined as the smallest set of consecutive bits that contains every bit in the register that is associated with the Serialization Instruction. If bits [6:5] and bits [3:2] all correspond to a Serialization Instruction, the bit range for that instruction would be [6:2].

Because a bit range could contain bits that do not pertain to a particular Serialization Instruction (i.e. bit 4 in the example above), a bit mask is required to distinguish all the bits in the region that correspond to the instruction. The Mask field is defined to be this bit mask with a bit set to ‘1’ for each bit in the bit range (defined by the register region) corresponding to the Serialization Instruction. Note that bit 0 of the bit mask corresponds to the lowest bit in the bit range. In the example used above, the mask would be 11011b or 0x1B.

The Instruction field identifies the operation to be performed on the register region by the instruction entry. The following table identifies the instructions that are supported.

Table 18.21: **Serialization Instructions**

Value	Name	Description
0x00	READ_REGISTER	A READ_REGISTER instruction reads the designated information from the specified Register Region.
0x01	READ_REGISTER_VALUE	A READ_REGISTER_VALUE instruction reads the designated information from the specified Register Region and compares the results with the contents of the Value field. If the information read matches the contents of the Value field, TRUE is returned, else FALSE is returned.
0x02	WRITE_REGISTER	A WRITE_REGISTER instruction writes a value to the specified Register Region. The Value field is ignored.
0x03	WRITE_REGISTER_VALUE	A WRITE_REGISTER_VALUE instruction writes the contents of the Value field to the specified Register Region.
0x04	NOOP	This instruction is a NOOP.
0x05	LOAD_VAR1	Loads the VAR1 variable from the register region.
0x06	LOAD_VAR2	Loads the VAR2 variable from the register region.
0x07	STORE_VAR1	Stores the value in VAR1 to the indicate register region.
0x08	ADD	Adds VAR1 and VAR2 and stores the result in VAR1.
0x09	SUBTRACT	Subtracts VAR1 from VAR2 and stores the result in VAR1.
0x0A	ADD_VALUE	Adds the contents of the specified register region to Value and stores the result in the register region.
0x0B	SUBTRACT_VALUE	Subtracts Value from the contents of the specified register region and stores the result in the register region.
0x0C	STALL	Stall for the number of microseconds specified in Value.

continues on next page

Table 18.21 – continued from previous page

Value	Name	Description
0x0D	STALL_WHILE_TRUE	OSPM continually compares the contents of the specified register region to Value until the values are not equal. OSPM stalls between each successive comparison. The amount of time to stall is specified by VAR1 and is expressed in microseconds.
0x0E	SKIP_NEXT_INSTRUCTION_IF_TRUE	This is a control instruction which compares the contents of the register region with Value. If the values match, OSPM skips the next instruction in the sequence for the current action.
0x0F	GOTO	OSPM will go to the instruction specified by Value. The instruction is specified as the zero-based index. Each instruction for a given action has an index based on its relative position in the array of instructions for the action.
0x10	SET_SRC_ADDRESS_BASE	Sets the SRC_BASE variable used by the MOVE_DATA instruction to the contents of the register region.
0x11	SET_DST_ADDRESS_BASE	Sets the DST_BASE variable used by the MOVE_DATA instruction to the contents of the register region.
0x12	MOVE_DATA	Moves VAR2 bytes of data from SRC_BASE + Offset to DST_BASE + Offset, where Offset is the contents of the register region.

The Flags field allows qualifying flags to be associated with the instruction. The following table identifies the flags that can be associated with Serialization Instructions.

Table 18.22: Instruction Flags

Value	Name	Description
0x01	PRESERVE_REGISTER	For WRITE_REGISTER and WRITE_REGISTER_VALUE instructions, this flag indicates that bits within the register that are not being written must be preserved rather than destroyed. For READ_REGISTER instructions, this flag is ignored.

18.5.1.2.1 READ_REGISTER_VALUE

A read register value instruction reads the register region and compares the result with the specified value. If the values are not equal, the instruction failed. This can be described in pseudo code as follows:

```
X = Read(register)
X = X >> Bit Offset described in Register Region
X = X & Mask
If (X != Value) FAIL
SUCCEED
```

18.5.1.2.2 READ_REGISTER

A read register instruction reads the register region. The result is a generic value and should not be compared with Value. Value will be ignored. This can be described in pseudo code as follows:

```
X = Read(register)
X = X >> Bit Offset described in Register Region
X = X & Mask
Return X
```

18.5.1.2.3 WRITE_REGISTER_VALUE

A write register value instruction writes the specified value to the register region. If PRESERVE_REGISTER is set in Instruction Flags, then the bits not corresponding to the write value instruction are preserved. If the register is preserved, the write value instruction requires a read of the register. This can be described in pseudo code as follows:

```
X = Value & Mask
X = X << Bit Offset described in Register Region
If (Preserve Register)
Y = Read(register)
Y = Y & ~(Mask << Bit Offset)
X = X \ | Y
Write(X, Register)
```

18.5.1.2.4 WRITE_REGISTER

A write register instruction writes a value to the register region. Value will be ignored. If PRESERVE_REGISTER is set in Instruction Flags, then the bits not corresponding to the write instruction are preserved. If the register is preserved, the write value instruction requires a read of the register. This can be described in pseudo code as follows:

```
X = supplied value
X = X & Mask
X = X << Bit Offset described in Register Region
If (Preserve Register)
Y = Read(register)
Y = Y & ~(Mask << Bit Offset)
X = X \ | Y
Write(X, Register)
```

18.5.1.3 Error Record Serialization Information

The APEI error record includes an 8 byte field called OSPM Reserved. The following table defines the layout of this field. The error record serialization information is a small buffer the platform can use for serialization bookkeeping. The platform is free to use the 48 bits starting at bit offset 16 for its own purposes. It may use these bits to indicate the busy/free status of an error record, to record an internal identifier, etc.

Table 18.23: Error Record Serialization Info

Field	Bit Length	Bit Offset	Description
Signature	16	0	16-bit signature ('ER') identifying the start of the error record serialization data.

continues on next page

Table 18.23 – continued from previous page

Field	Bit Length	Bit Offset	Description
Platform Serialization Data	48	16	Platform private error record serialization information.

18.5.2 Operations

The error record serialization interface comprises three operations: Write, Read, and Clear. OSPM uses the Write operation to write a single error record to the persistent store. The Read operation is used to retrieve a single error record previously recorded to the persistent store using the write operation. The Clear operation allows OSPM to notify the platform that a given error record has been fully processed and is no longer needed, allowing the platform to recover the storage associated with a cleared error record.

Where the Error Log Address Range is NVRAM, significant optimizations are possible since transfer from the Error Log Address Range to a separate storage device is unnecessary. The platform may still, however, copy the record from NVRAM to another device, should it choose to. This allows, for example, the platform to copy error records to private log files. In order to give the platform the opportunity to do this, OSPM must use the Write operation to persist error records even when the Error Log Address Range is NVRAM. The Read and Clear operations, however, are unnecessary in this case as OSPM is capable of reading and clearing error records without assistance from the platform.

18.5.2.1 Writing

To write a single HW error record, OSPM executes the following steps:

1. Initializes the error record's serialization info. OSPM must fill in the Signature.
2. Writes the error record to be persisted into the Error Log Address Range.
3. Executes the BEGIN_WRITE_OPERATION action to notify the platform that a record write operation is beginning.
4. Executes the SET_RECORD_OFFSET action to inform the platform where in the Error Log Address Range the error record resides.
5. Executes the EXECUTE_OPERATION action to instruct the platform to begin the write operation.
6. Busy waits by continually executing CHECK_BUSY_STATUS action until FALSE is returned.
7. Executes a GET_COMMAND_STATUS action to determine the status of the write operation. If an error is indicated, the OS
8. PM may retry the operation.
9. Executes an END_OPERATION action to notify the platform that the record write operation is complete.

When OSPM performs the EXECUTE_OPERATION action in the context of a record write operation, the platform attempts to transfer the error record from the designated offset in the Error Log Address Range to a persistent store of its choice. If the Error Log Address Range is non-volatile RAM, no transfer is required.

Where the platform is required to transfer the error record from the Error Log Address Range to a persistent store, it performs the following steps in response to receiving a write command:

1. Sets some internal state to indicate that it is busy. OSPM polls by executing a CHECK_BUSY_STATUS action until the operation is completed.
2. Reads the error record's *Record ID* field to determine where on the storage medium the supplied error record is to be written. The platform attempts to locate the specified error record on the persistent store.

- If the specified error record does not exist, the platform attempts to write a new record to the persistent store.
 - If the specified error record does exist, then if the existing error record is large enough to be overwritten by the supplied error record, the platform can do an in-place replacement. If the existing record is not large enough to be overwritten, the platform must attempt to locate space in which to write the new record. It may mark the existing record as Free and coalesce adjacent free records in order to create the necessary space.
3. Transfers the error record to the selected location on the persistent store.
 4. Updates an internal *Record Count* if a new record was written.
 5. Records the status of the operation so OSPM can retrieve the status by executing a GET_COMMAND_STATUS action.
 6. Modifies internal busy state as necessary so when OS PM executes CHECK_BUSY_STATUS, the result indicates that the operation is complete.

If the Error Log Address Range resides in NVRAM, the minimum steps required of the platform are:

1. Sets some internal state to indication that it is busy. OSPM polls by executing a CHECK_BUSY_STATUS action until the operation is completed.
2. Records the status of the operation so OSPM can retrieve the status by executing a GET_COMMAND_STATUS action.
3. Clear internal busy state so when OS PM executes CHECK_BUSY_STATUS, the result indicates that the operation is complete.

18.5.2.2 Reading

During boot, OSPM attempts to retrieve all serialized error records from the persistent store. If the Error Log Address Range does not reside in NVRAM, the following steps are executed by OSPM to retrieve all error records:

1. Executes the BEGIN_READ_OPERATION action to notify the platform that a record read operation is beginning.
2. Executes the SET_RECORD_OFFSET action to inform the platform at what offset in the Error Log Address Range the error record is to be transferred.
3. Executes the SET_RECORD_IDENTIFIER action to inform the platform which error record is to be read from its persistent store.
4. Executes the EXECUTE_OPERATION action to instruct the platform to begin the read operation.
5. Busy waits by continually executing CHECK_BUSY_STATUS action until FALSE is returned.
6. Executes a GET_COMMAND_STATUS action to determine the status of the read operation.
 - If the status is Record Store Empty (0x04), continue to step 7.
 - If an error occurred reading a valid error record, the status will be Failed (0x03), continue to step 7.
 - If the status is Record Not Found (0x05), indicating that the specified error record does not exist, OSPM retrieves a valid identifier by executing a GET_RECORD_IDENTIFIER action. The platform will return a valid record identifier.
 - If the status is Success, OSPM transfers the retrieved record from the Error Log Address Range to a private buffer and then executes the GET_RECORD_IDENTIFIER action to determine the identifier of the next record in the persistent store.
7. Execute an END_OPERATION to notify the platform that the record read operation is complete.

The steps performed by the platform to carry out a read request are as follows:

1. Sets some internal state to indicate that it is busy. OSPM polls by executing a CHECK_BUSY_STATUS action until the operation is completed.
2. Using the record identifier supplied by OSPM through the SET_RECORD_IDENTIFIER operation, determine which error record to read:
 - If the identifier is 0x0 (unspecified), the platform reads the 'first' error record from its persistent store (first being implementation specific).
 - If the identifier is non-zero, the platform attempts to locate the specified error record on the persistent store.
 - If the specified error record does not exist, set the status register's Status to Record Not Found (0x05), and update the status register's Identifier field with the identifier of the 'first' error record.
3. Transfer the record from the persistent store to the offset specified by OSPM from the base of the Error Log Address Range.
4. Record the Identifier of the 'next' valid error record that resides on the persistent store. This allows OSPM to retrieve a valid record identifier by executing a GET_RECORD_IDENTIFIER operation.
5. Record the status of the operation so OSPM can retrieve the status by executing a GET_COMMAND_STATUS action.
6. Clear internal busy state so when OSPM executes CHECK_BUSY_STATUS, the result indicates that the operation is complete.

Where the Error Log Address Range does reside in NVRAM, OSPM requires no platform support to read persisted error records. OSPM can scan the Error Log Address Range on its own and retrieve the error records it previously persisted.

18.5.2.3 Clearing

After OSPM has finished processing an error record, it will notify the platform by clearing the record. This allows the platform to delete the record from the persistent store or mark it such that the space is free and can be reused. The following steps are executed by OSPM to clear an error record:

1. Executes a BEGIN_CLEAR_OPERATION action to notify the platform that a record clear operation is beginning.
2. Executes a SET_RECORD_IDENTIFIER action to inform the platform which error record is to be cleared. This value must not be set to 0x0 (unspecified).
3. Executes an EXECUTE_OPERATION action to instruct the platform to begin the clear operation.
4. Busy waits by continually executing CHECK_BUSY_STATUS action until FALSE is returned.
5. Executes a GET_COMMAND_STATUS action to determine the status of the clear operation.
6. Execute an END_OPERATION to notify the platform that the record read operation is complete.

The platform carries out a clear request by performing the following steps:

1. Sets some internal state to indication that it is busy. OSPM polls by executing a CHECK_BUSY_STATUS action until the operation is completed.
2. Using the record identifier supplied by OSPM through the SET_RECORD_IDENTIFIER operation, determine which error record to clear. This value may not be 0x0 (unspecified).
3. Locate the specified error record on the persistent store.
4. Mark the record as free by updating the Attributes in its serialization header.

5. Update internal record count.
6. Clear internal busy state so when OS PM executes CHECK_BUSY_STATUS, the result indicates that the operation is complete.

When the Error Log Address Range resides in NVRAM, the OS requires no platform support to Clear error records.

18.5.2.4 Usage

This section describes several possible ways the error record serialization mechanism might be implemented.

18.5.2.4.1 Error Log Address Range Resides in NVRAM

If the *Error Log Address Range* resides in NVRAM, then when OSPM writes a record into the logging range, the record is automatically persistent and the busy bit can be cleared immediately. On a subsequent boot, OSPM can read any persisted error records directly from the persistent store range. The size of the persistent store, in this case, is expected to be enough for several error records.

18.5.2.4.2 Error Log Address Range Resides in (volatile) RAM

In this implementation, the Error Log Address Range describes an intermediate location for error records. To persist a record, OSPM copies the record into the Error Log Address Range and sets the Execute, at which time the platform runs necessary code (SMM code on non-UEFI based systems and UEFI runtime code on UEFI-enabled systems) to transfer the error record from main memory to some persistent store. To read a record, OSPM asks the platform to copy a record from the persistent store to a specified offset within the Error Log Address Range. The size of the Error Log Address Range is at least large enough for one error record.

18.5.2.4.3 Error Log Address Range Resides on Service Processor

In this type of implementation, the Error Log Address Range is really MMIO. When OSPM writes an error record to the Error Log Address Range, it is really writing to memory on a service processor. When the OSPM sets the Execute control bit, the platform knows that the OSPM is done writing the record and can do something with it, like move it into a permanent location (i.e. hard disk) on the service processor. The size of the persistent store in this type of implementation is typically large enough for one error record.

18.5.2.4.4 Error Log Address Range is Copied Across Network

In this type of implementation, the Error Log Address Range is an intermediate cache for error records. To persist an error record, OSPM copies the record into the Error Log Address Range and set the Execute control bit, and the platform runs code to transmit this error record over the wire. The size of the Error Log Address Range in this type of implementation is typically large enough for one error record.

18.6 Error Injection

This section outlines an ACPI table mechanism, called EINJ, which allows for a generic interface mechanism through which OSPM can inject hardware errors to the platform without requiring platform specific OSPM level software. The primary goal of this mechanism is to support testing of OSPM error handling stack by enabling the injection of hardware errors. Through this capability OSPM is able to implement a simple interface for diagnostic and validation of errors handling on the system.

18.6.1 Error Injection Table (EINJ)

The Error Injection (EINJ) table provides a generic interface mechanism through which OSPM can inject hardware errors to the platform without requiring platform specific OSPM software. System firmware is responsible for building this table, which is made up of Injection Instruction entries. The following table describes the necessary details for EINJ.

Table 18.24: Error Injection Table (EINJ)

Field	Byte length	Byte offset	Description
ACPI Standard Header			
Header Signature	4	0	EINJ. Signature for the Error Record Injection Table.
Length	4	4	Length, in bytes, of entire EINJ. Entire table must be contiguous.
Revision	1	8	2
Checksum	1	9	Entire table must sum to zero.
OEMID	6	10	OEM ID.
OEM Table ID	8	16	The manufacturer model ID.
OEM Revision	4	24	OEM revision of EINJ.
Creator ID	4	28	Vendor ID of the utility that created the table.
Creator Revision	4	32	Revision of the utility that created the table.
Injection Header			
Injection Header Size	4	36	Length in bytes of the Injection Interface header.
Injection Flags	1	40	Reserved. Must be zero
<i>Reserved</i>	3	41	Must be zero.
Injection Entry Count	4	44	The number of Instruction Entries in the Injection Action Table
Injection Action Table			
Injection Instruction Entries		48	A series of error injection instruction entries, per Injection Entry Count See Table 18.26 .

The following table identifies the supported error injection actions.

Table 18.25: Error Injection Actions

Value	Name	Description
0x0	BEGIN_INJECTION_OPERATION	Indicates to the platform that an error injection is beginning. This allows the platform to set its operational context.

continues on next page

Table 18.25 – continued from previous page

0x1	GET_TRIGGER_ERROR_ACTION- _TABLE	Returns a 64-bit physical memory pointer to the Trigger Action Table. See Table 18.36
0x2	SET_ERROR_TYPE	Type of error to Inject. Only one ERROR_TYPE can be injected at any given time. If there is request for multiple injections at the same time, then the platform will return an error condition. See Section 18.6.4 .
0x3	GET_ERROR_TYPE	Returns the error injection capabilities of the platform.
0x4	END_OPERATION	Indicates to the platform that the current injection operation has ended. This allows the platform to clear its operational context.
0x5	EXECUTE_OPERATION	Instructs the platform to carry out the current operation based on the current operational context.
0x6	CHECK_BUSY_STATUS	Returns the state of the current operation. Once an operation has been executed through the EXECUTE_OPERATION action, the platform is required to return an indication that the operation is busy until the operation is completed. This allows software to poll for completion by repeatedly executing the CHECK_BUSY_STATUS action until the platform indicates that the operation is complete by setting not busy. The lower most bit (bit0) of the returned value indicates the busy status by setting it to 1 and not busy status by setting it to 0.
0x7	GET_COMMAND_STATUS	Returns the status of the current operation. See Table 18.29 for a list of valid command status codes.
0x8	SET_ERROR_TYPE- _WITH_ADDRESS	Type of error to Inject, and the address to inject. Only one Error type can be injected at any given time. If there is request for multiple injections at the same time, then the platform will return an error condition. The RegisterRegion field (See Table 18.26) in SET_ERROR_TYPE_WITH_ADDRESS points to a data structure whose format is defined in Table 18.31 . Note that executing SET_ERROR_TYPE_WITH_ADDRESS without specifying an address has the same effect as executing SET_ERROR_TYPE. See Table 18.30 , error type definition.

continues on next page

Table 18.25 – continued from previous page

0x9	GET_EXECUTE_OPERATION- _TIMINGS	Returns an encoded QWORD: [63:32] value in microseconds that the platform expects would be the maximum amount of time it will take to process and complete an EXECUTE_OPERATION. [31:0] value in microseconds that the platform expects would be the nominal amount of time it will take to process and complete an EXECUTE_OPERATION.
0x10	EINJV2_SET_ERROR_TYPE	New Error Injection action introduced in EINJv2 for the purpose of injecting an EINJv2 error type, with address, severity, and detailed syndrome. Only one Error type can be injected at any given time. For multiple injections at the same time, then the platform will return an error condition. The RegisterRegion field (see Table 18.26) in EINJV2_SET_ERROR_TYPE points to a data structure whose format is defined in Table 18.34 See Section 18.6.4.1, for the EINJv2 error type definition.
0x11	EINJV2_GET_ERROR_TYPE	Returns the extended error injection capabilities (EINJv2 features) of the platform: Bit 0 - EINJv2 Processor Error Type supported Bit 1 - EINJv2 Memory Error Type supported Bit 2 - EINJv2 PCIe Error Type supported Bit 3-30 - Reserved (Must be zero) Bit 31 - EINJv2 Vendor specific error codes
0xFF	TRIGGER_ERROR	This Value is reserved for entries declared in the Trigger Error Action Table returned in response to a GET_TRIGGER_ERROR_ACTION_TABLE action. The returned table consists of a series of actions each of which is set to TRIGGER_ERROR (see Table 18.36). When executed by software, the series of TRIGGER_ERROR actions triggers the error injected as a result of the successful completion of an EXECUTE_OPERATION action.

18.6.2 Injection Instruction Entries

An Injection action consists of a series of one or more Injection Instructions. An Injection Instruction represents a primitive operation on an abstracted hardware register, represented by the register region as defined in an Injection Instruction Entry.

An Injection Instruction Entry describes a region in an injection hardware register and the injection instruction to be performed on that region.

The following table details the layout of an Injection Instruction Entry.

Table 18.26: Injection Instruction Entry

Field	Byte length	Byte offset	Description
Injection Action	1	0	The injection action that this instruction is a part of. See the Error Injection Actions table for supported injection actions.
Instruction	1	1	Identifies the instruction to execute. See the Injection Instructions table for a list of valid instructions.
Flags	1	2	Flags that qualify the instruction.
<i>Reserved</i>	1	3	Must be zero.
Register Region	12	4	The Generic Address Structure is used to describe the address and bit. Address_Space_ID must be 0 (System Memory) or 1 (System IO). This constraint is an attempt to ensure that the registers are accessible in the presence of hardware error conditions.
Value	8	16	This is the value field that is used by the instruction READ or WRITE_REGISTER_VALUE.
Mask	8	24	The bit mask required to obtain the bits corresponding to the injection instruction in a given bit range defined by the register region.

Register Region is described as a generic address structure. This structure describes the physical address of a register as well as the bit range that corresponds to a desired region of the register. The bit range is defined as the smallest set of consecutive bits that contains every bit in the register that is associated with the injection Instruction. If bits [6:5] and bits [3:2] all correspond to an Injection Instruction, the bit range for that instruction would be [6:2].

Because a bit range could contain bits that do not pertain to a particular injection Instruction (i.e. bit 4 in the example above), a bit mask is required to distinguish all the bits in the region that correspond to the instruction. The Mask field is defined to be this bit mask with a bit set to a ‘1’ for each bit in the bit range (defined by the register region) corresponding to the Injection Instruction. Note that bit 0 of the bit mask corresponds to the lowest bit in the bit range. In the example used above, the mask would be 11011b or 0x1B.

Table 18.27: Instruction Flags

Value	Name	Description
0x01	PRESERVE_REGISTER	For WRITE_REGISTER and WRITE_REGISTER_VALUE instructions, this flag indicates that bits within the register that are not being written must be preserved rather than destroyed. For READ_REGISTER instructions, this flag is ignored.

18.6.3 Injection Instructions

The table below lists the supported Injection Instructions for Injection Instruction Entries.

Table 18.28: Injection Instructions

Opcode	Instruction name	Description
0x00	READ_REGISTER	A READ_REGISTER instruction reads the value from the specified register region.
0x01	READ_REGISTER_VALUE	A READ_REGISTER_VALUE instruction reads the designated information from the specified Register Region and compares the results with the contents of the Value field. If the information read matches the contents of the Value field, TRUE is returned, else FALSE is returned.
0x02	WRITE_REGISTER	A WRITE_REGISTER instruction writes a value chosen by software to the specified Register Region. The Value field is ignored.

continues on next page

Table 18.28 – continued from previous page

Opcode	Instruction name	Description
0x03	WRITE_REGISTER_VALUE	A WRITE_REGISTER_VALUE instruction writes the contents of the Value field to the specified Register Region.
0x04	NOOP	No operation.

The table below defines the error injection status codes returned from GET_COMMAND_STATUS.

Table 18.29: Command Status Definition

Value	Description
0x0	Success
0x1	Unknown Failure
0x2	Invalid Access

18.6.4 Error Types

The table below defines the error type codes returned from GET_ERROR_TYPE, as well as the error type set by SET_ERROR_TYPE and the Error Type field set by SET_ERROR_TYPE_WITH_ADDRESS (see Table 18.31).

Both the SET_ERROR_TYPE and SET_ERROR_TYPE_WITH_ADDRESS actions must be present as part of the EINJ Action Table. OSPM is free to choose either of these two actions to inject an error type. The platform will give precedence to SET_ERROR_TYPE_WITH_ADDRESS. That is, if a non-zero Error Type value is set by SET_ERROR_TYPE_WITH_ADDRESS, then any Error Type value set by SET_ERROR_TYPE will be ignored. But if no Error Type is specified by SET_ERROR_TYPE_WITH_ADDRESS, then the platform will use SET_ERROR_TYPE to identify the error type to inject.

Table 18.30: Error Type Definition

Bit	Description
0	Processor Correctable
1	Processor Uncorrectable non-fatal
2	Processor Uncorrectable fatal
3	Memory Correctable
4	Memory Uncorrectable non-fatal
5	Memory Uncorrectable fatal
6	PCI Express Correctable
7	PCI Express Uncorrectable non-fatal
8	PCI Express Uncorrectable fatal
9	Platform Correctable
10	Platform Uncorrectable non-fatal
11	Platform Uncorrectable fatal
12	CXL.cache Protocol Correctable
13	CXL.cache Protocol Uncorrectable non-fatal
14	CXL.cache Protocol Uncorrectable fatal
15	CXL.mem Protocol Correctable
16	CXL.mem Protocol Uncorrectable non-fatal
17	CXL.mem Protocol Uncorrectable fatal
18:29	RESERVED

continues on next page

Table 18.30 – continued from previous page

30	<p>EINJV2 Error Type. If this bit is set, then the support for EINJV2_SET_ERROR_TYPE and EINJV2_GET_ERROR_TYPE actions are supported.</p> <p>NOTE: This may only be used with the action GET_ERROR_TYPE and it is not permitted to set this bit with SET_ERROR_TYPE or SET_ERROR_TYPE_WITH_ADDRESS</p>
31	<p>Vendor Defined Error Type. If this bit is set, then the Error types and related data structures are defined by the Vendor, as shown in Table 18.32.</p>

Note: CXL errors (Bits 17:12) are intended to target the CXL port (for example via Link or Protocol errors, not actual Component errors).

Table 18.31: SET_ERROR_TYPE_WITH_ADDRESS Data Structure

Field	Byte Length	Byte Offset	Description
Error Type	4	0	Bitmap of error types to inject. See Table 18.30. This field is cleared by the platform once it is consumed.
Vendor Error Type Extension Structure Offset	4	4	Specifies the offset from the beginning of the table to the vendor error type extension structure. If no vendor error type extension is present, bit31 in error type must be clear and this field must be set to 0.
Flags	4	8	<p>Bit [0] - Processor Identification Field Valid</p> <p>Bit [1]- Memory Address and Memory address Mask Field Valid</p> <p>NOTE: For CXL errors, the Memory Address points to a CXL 1.1 compliant memory-mapped Downstream port</p> <p>Bit [2] - PCIe SBDF field valid</p> <p>NOTE: For CXL errors, the SBDF points to a CXL 2.0 compliant Root port.</p> <p>Bit [31:3] - RESERVED</p> <p>This field is cleared by the platform once it is consumed.</p>
Processor Error			
Processor Identification	4	12	Optional field: on non-ARM architectures, this is the physical APIC ID or the X2APIC ID of the processor which is a target for the injection; on ARM systems, this is the ACPI Processor UID value as used in the MADT.
Memory Error			
Memory Address	8	16	Optional field specifying the physical address of the memory that is the target for the injection. Valid if Bit [1] of the Flags field is set.
Memory Address Range	8	24	Optional field that provides a range mask for the address field. Valid if Bit [1] of the Flags field is set. If the OSPM doesn't want to provide a range of addresses, then this field should be zero.

continues on next page

Table 18.31 – continued from previous page

PCIe SBDF	4	32	Byte 3 - PCIe Segment Byte 2 - Bus Number Byte 1: Bits [7:3] Device Number Bits [2:0] Function Number Byte 0 - RESERVED
-----------	---	----	--

Table 18.32: Vendor Error Type Extension Structure

Field	Byte Length	Byte Offset	Attribute	Description
Length	4	0x0	Set by Platform. RO for Software.	Length, in bytes, of the entire Vendor Error Type Extension Structure.
SBDF	4	0x04	Set by Platform. RO for Software	This provides a PCIe Segment, Bus, Device and Function number which can be used to read the Vendor ID, Device ID and Rev ID, so that software can identify the system for error injection purposes. The platform sets this field and is RO for Software.
Vendor ID	2	0x08	Set by Platform. RO for Software	Vendor ID which identifies the device manufacturer. This is the same as the PCI SIG defined Vendor ID. The platform sets this field and is RO for Software
Device ID	2	0x0A	Set by Platform. RO for Software	This 16-bit ID is assigned by the manufacturer that identifies this device. The platform sets this field and is RO for Software
Rev ID	1	0x0C	Set by Platform. RO for Software	This 8-bit value is assigned by the manufacturer and identifies the revision number of the device. The platform sets this field and is RO for Software
<i>Reserved</i>	3	0x0D	Set by Platform. RO for Software	<i>Reserved</i>
OEM Defined structure	N	0x10		The rest of the fields are defined by the OEM.

18.6.4.1 EINJv2 Error Types

EINJ version 2 (EINJv2) introduces a new error injection action. The table below defines the error type codes returned from EINJV2_GET_ERROR_TYPE, as well as the error type set by EINJV2_SET_ERROR_TYPE.

EINJV2_SET_ERROR_TYPE actions must be present as part of the EINJ Action Table. OSPM is free to choose this action for advanced error injection options. The platform will give precedence to EINJV2_SET_ERROR_TYPE. That is, if a non-zero Error Type value is set by EINJV2_SET_ERROR_TYPE, then any Error Type value set by SET_ERROR_TYPE_WITH_ADDRESS and/or SET_ERROR_TYPE will be ignored.

Also, EINJv2 breaks out the Error Type from the severity. The following table describes the new Error Type encoding.

Table 18.33: EINJv2 Error Type

Bit	Description
0	Processor Error
1	Memory Error
2	PCIe Error
3-30	<i>Reserved</i>
31	Vendor Defined Error

Table 18.34: EINJV2_SET_ERROR_TYPE Data Structure

Field	Byte Length	Byte Offset	Description
Error Type	4	0	Bit map of error types to inject (see Table 18.30). Only one Error Type bit may be set at a time. This field is cleared by the platform once it is consumed.
Error Type Code	1	4	Vendor specific code for each error type used to indicate error injection behavior. Value of zero is default error injection behavior as defined by EINJv2. Non-zero value indicates vendor specific behavior.
Flags	3	5	This field indicates which of the remaining fields are valid: Bit 0 - Address Valid Bit 1 - Address Range Valid Bit 2 - Severity Valid Bit 3 - Component Syndrome Count and Array is valid All other bits are reserved
Length	4	8	This specifies the length of the entire structure including the component syndrome array.
Severity	4	12	Optional field specifying the severity of the injected error: 0 - Corrected Error 1 - Uncorrected Non-Fatal 2 - Uncorrected Fatal All other values are reserved
Address	8	16	Optional field specifying the physical address of the memory that is the target for the injection. Valid if Bit [0] of the Flags field is set.
Address Range	8	24	Optional field specifying the physical address range mask of the memory that is the target for the injection. Valid if Bit [1] of the Flags field is set.
Component Syndrome Count (N)	4	28	This represents the maximum number of components supported in the Component Syndrome Array. This is intended to support injecting an error into multiple components / devices simultaneously. For Example: If Component Syndrome Count is valid per the Flags field and the value Count (N) is 4, this structure contains the error Component Syndrome Array for 4 unique components.
Component Syndrome Array	N * 32	32	This is an array based on the Component Syndrome Entry Structure, each entry being 32-bytes as described in Table 18.35 . The length of this structure is 32 x Component Syndrome Count.

Table 18.35: EINJV2_SET_ERROR_TYPE Component Syndrome Structure

Field	Byte Length	Byte Offset	Description
Component ID	16	0	<p>Component ID definition depends on the Error Type Value. Note that because this is a union structure, the byte length is 16 bytes to accommodate the largest possible ID (i.e. FRU ID for vendor specific errors).</p> <p>Processor Error (0x1): The bottom 32-bit represents the ACPI ID (represented in MADT) of the processor. The remaining bits are vendor specific.</p> <p>Memory Error (0x2): This represents the Device ID within the memory module (e.g. DDR DIMM) for a particular system physical address. For example: 18 x 4 DIMMs support up to 18 devices (0-17) per address. 9 x 8 DIMMs support up to 9 devices (0-8) per address. It is possible to inject error syndrome into multiple device instances up to the Component Syndrome Count.</p> <p>PCIe Error (0x4): This represents the SBDF.</p> <p>Vendor Specific Error (0x80000000) This represents some platform specific identifier (e.g. FRU ID or other vendor specific error format).</p>
Component Syndrome	16	16	<p>The Component Syndrome definition depends on the Error Type Value.</p> <p>Processor Error (0x1): The usage of the syndrome bits will be vendor specific.</p> <p>Memory Error (0x2): This indicates bit mask of data bits that must be flipped within a memory device. (e.g. If the set syndrome bit value is zero, the bit value will be changed to one. if the set syndrome bit value is one, the bit value will be changed to zero). The range of valid bits depends on the component error injection granularity. Example 1: For a DDR4 18x4 memory device topology with a burst length of 8 (e.g., 64-byte cache line in a single burst), there will be up to 32 valid bits per device that may be modified per burst. If bit 3 in this mask is set, bit offset 3 of the device in that burst will be flipped. Example 2: For a DDR5 5x8 memory device topology with a burst length of 16 (e.g., 64-byte cache line in a single burst), there will be up to 128 valid bits per device that may be modified per burst.</p> <p>PCIe Error (0x4): The usage of the syndrome bits will be vendor specific.</p> <p>Vendor Specific Error (0x80000000) The usage of the syndrome bits will be vendor specific.</p>

18.6.5 Trigger Action Table

An error injection operation is a two-step process where the error is injected into the platform and subsequently triggered. After software injects an error into the platform using the EXECUTE_OPERATION action, it then needs to trigger the error. In order to trigger the error, software executes the GET_TRIGGER_ERROR_ACTION_TABLE action, which returns a pointer to a Trigger Error Action table. The format of this table is shown in the table below. Software then executes the instruction entries specified in the Trigger Error Action Table in order to trigger the injected error.

Table 18.36: Trigger Error Action

TRIGGER_ERROR Header	Byte Length	Byte Offset	Description
Header Size	4	0	Length in bytes of this header.
Revision	4	4	
Table Size	4	8	Size in Bytes of the entire table.
Entry Count	4	12	The number of Instruction Entries in the TRIGGER_ERROR Action Sequence - see note (1) below.
Action Table			
TRIGGER_ERROR Instruction Entries - see note (2) below		16	A series of error injection instruction entries as defined in Table 18-405.

Note: (1) If the “Entry Count” field above is ZERO, then there are no action structures in the TRIGGER_ERROR action table. The platform may make this field ZERO in situations where there is no need for a TRIGGER_ERROR action (for example, in cases where the error injection action seeds as well as consumes the error).

Note: (2) The format of TRIGGER_ERROR Instructions Entries is the same as Injection Instruction entries as described in Table 18-407.

18.6.6 Error Injection Operation

Before OSPM can use this mechanism to inject errors, it must discover the error injection capabilities of the platform by executing a GET_ERROR_TYPE. See Table 18.30 for a definition of error types.

After discovering the error injection capabilities, OSPM can inject and trigger an error according to the sequence described below.

Note that injecting an error into the platform does not automatically consume the error. In response to an error injection, the platform returns a trigger error action table. The software that injected the error must execute the actions in the trigger error action table in order to consume the error. If a specific error type is such that it is automatically consumed on injection, the platform will return a trigger error action table consisting of NO_OP.

1. Executes a BEGIN_INJECTION_OPERATION action to notify the platform that an error injection operation is beginning.
2. Executes a GET_ERROR_TYPE action to determine the error injection capabilities of the system. This action returns a DWORD bit map of the error types supported by the platform (see Table 18.30).
3. If GET_ERROR_TYPE returns the DWORD with Bit [31] set, it means that vendor defined error types are present, apart from the standard error types (see Table 18.30).
4. OSPM chooses the type of error to inject by executing a SET_ERROR_TYPE or a SET_ERROR_TYPE_WITH_ADDRESS_WITH_ADDRESS action (see Section 18.6.4).

- a. If the OSPM chooses to inject one of the supported standard error types, then it sets the corresponding bit in the error type bitmap. For example, if OSPM chooses to inject a “Memory Correctable” error, then the OSPM sets the value 0x0000_0080 in the error type bitmap.
- b. If the OSPM chooses to inject one of the vendor defined error types, then it sets bit[31] in the error type bitmap.

* OSPM executes the SET_ERROR_TYPE_WITH_ADDRESS_WITH_ADDRESS action to retrieve the location of the “SET_ERROR_TYPE_WITH_ADDRESS data structure”, to then get the location of the “Vendor Error Type Extension Structure” by reading the “Vendor Error Type Extension Structure Offset” (see Table 18.32).

- OSPM reads the Vendor ID, Device ID and Rev ID from the PCI config space whose path (PCIe Segment/Device/Function) is provided in the “SBDF” field of the Vendor Error Type Extension Structure.

- If the Vendor ID/Device ID and Rev IDs match, then the OSPM can identify the platform it is running on and would know the Vendor error types that are supported by this platform.

- The OSPM writes the vendor error type to inject in the “OEM Defined Structure” field (see Table 18.32).

* Optionally, for either standard or vendor-defined error types, the OSPM can choose the target of the injection, such as a memory range, PCIe Segment/Device/Function or Processor APIC ID, depending on the type of error. The OSPM does this by executing the SET_ERROR_TYPE_WITH_ADDRESS action to fill in the appropriate fields of the “SET_ERROR_TYPE_WITH_ADDRESS Data structure” (see Table 18.31).

5. Executes an EXECUTE_OPERATION action to instruct the platform to begin the injection operation.
6. Busy waits by continually executing CHECK_BUSY_STATUS action until the platform indicates that the operation is complete by clearing the abstracted Busy bit.
7. Executes a GET_COMMAND_STATUS action to determine the status of the completed operation.
8. If the status indicates that the platform cannot inject errors, stop.
9. Executes a GET_TRIGGER_ERROR_ACTION_TABLE operation to get the physical pointer to the TRIGGER_ERROR action table. This provides the flexibility in systems where injecting an error is a two (or more) step process.
10. Executes the actions specified in the TRIGGER_ERROR action table.
11. Execute an END_OPERATION to notify the platform that the error injection operation is complete.

18.6.7 Error Injection Version 2 Operation

Before OSPM can use this mechanism to inject errors, it must discover the error injection capabilities of the platform by executing a EINJV2_GET_ERROR_TYPE. See Table 18.30 for a definition of error types.

After discovering the EINJV2 error injection capabilities, OSPM can inject and trigger an error according to the sequence described below.

Note that injecting an error into the platform does not automatically consume the error. In response to an error injection, the platform returns a trigger error action table. The software that injected the error must execute the actions in the trigger error action table in order to consume the error. If a specific error type is such that it is automatically consumed on injection, the platform will return a trigger error action table consisting of NO_OP:

1. Executes a BEGIN_INJECTION_OPERATION action to notify the platform that an error injection operation is beginning.

2. Executes a EINJ_GET_ERROR_TYPE action to determine the error injection capabilities of the system. This action returns a DWORD bit map of the error types supported by the platform (see Table 18.30).
3. If EINJV2_GET_ERROR_TYPE returns the DWORD with Bit [30] set, it means that EINJv2 error types are present, apart from the standard error types (see Table 18.30).
4. Executes a EINJV2_GET_ERROR_TYPE action to determine the error injection capabilities of the system. This action returns a DWORD bit map of the error types supported by the platform (see Table 18.33).
5. If EINJV2_GET_ERROR_TYPE returns the DWORD with Bit [1] set, it means that memory error types are present.
6. OSPM chooses the type of error to inject by executing a EINJV2_SET_ERROR_TYPE action.

- a. If the OSPM chooses to inject one of the supported standard error types, then it sets the corresponding bit in the error type bitmap.

For example: if OSPM chooses to inject a Memory error, then the OSPM sets the value 0x0000_0002 in the error type bitmap. If OSPM chooses to inject a memory error pattern into a device at a particular DRAM address, the Flags will be set to 0x9 to indicate component syndrome and address are valid. OSPM will populate the Address field with the system physical address and the component syndrome count and array syndrome.

Error Type = 0x2 (Memory Error)

Error Code = 0x0 (no vendor specific behavior)

Length=0x44

Severity=0 (not used)

Address=0000FFFFFFFF00000

Address Range=0x0

Flags = 0x9 (Address and Component Syndrome Array is Valid)

Component Syndrome Count = 1

Component Syndrome Array [0] = { 000000000000000000000000000000004 ,
000000000000000000000000A5A5A5A5 }

So in this example software is trying to inject a 32-bit bit flip pattern on one device across a single burst for a particular system physical address.

EINJV2_SET_ERROR_TYPE=000000000000000000000000A5A5A5A50000000000000000000000000000000040000000
000000000000FFFFFFFF00000000000000000044000009000000002

7. Executes an EXECUTE_OPERATION action to instruct the platform to begin the injection operation.
8. Busy waits by continually executing CHECK_BUSY_STATUS action until the platform indicates that the operation is complete by clearing the abstracted Busy bit.
9. Executes a GET_COMMAND_STATUS action to determine the status of the completed operation.
10. If the status indicates that the platform cannot inject errors, stop.

18.7 GHES_ASSIST Error Reporting

In some cases, errors reported by hardware may provide a limited amount of information, as additional information may require platform-specific knowledge. Hence, the GHES_ASSIST mechanism, as marked in the Flags field of a given Error Source Structure, allows system firmware to provide additional information in the context of an error reported by hardware. Specifically, system firmware provides additional information via a Generic Hardware Error Source (GHES) structure which has its *Related Source ID* pointing back to the Error Source structure that represents the hardware. OSPM conveys support for GHES_ASSIST as declared by the *GHES_ASSIST Support* flag of the Platform-Wide _OSC Capabilities DWORD 2. See Section 6.2.11.2, *Platform-Wide OSPM Capabilities*.

Note: System firmware must ensure that additional information provided by GHES_ASSIST structures is aligned with the current error status information reported by the hardware. The implication is that as errors are generated by the hardware, system firmware must have mechanisms to get control before those errors are delivered to OSPM.

Since OSPM is expected to consume the additional GHES_ASSIST information in the context of an error reported by hardware, the Notification Structure associated with the pertinent GHES should have the Type field set to *Polled*, or a type that is aligned with the signaling of the hardware error event. See Table 18.14, *Hardware Error Notification Structure*.

OSPM is expected clear the hardware error condition after consuming any additional information from the pertinent GHES_ASSIST structures.

18.7.1 GHES_ASSIST on Machine Check Architecture

To support GHES_ASSIST on Machine Check Architecture (MCA) error sources, system firmware provides a set of GHES structures for each MCA error source (see Table 18.3 Machine Check Exception, Table 18.5 Corrected Machine Check, and Table 18.15 Deferred Machine Check). Each set consists of a GHES structure per MCA bank on each Logical Processor (CPU), where the GHES structures from each set share a common *Related Source ID*.

For each MCA error source, OSPM can index through the set of GHES_ASSIST structures using the following formula:

$$\text{Index} = ((\text{CPU number}) * (\text{MCA Banks per CPU})) + (\text{MCA Bank index})$$

Where *CPU number* represents the index of the corresponding Processor Local APIC or x2APIC structure with (Flags.Enabled = 1) in MADT (e.g. 0 represents the first enabled Processor Local APIC or x2APIC entry in MADT), and *MCA Banks per CPU* represents the value of the *Number Of Hardware Banks* field from the pertinent MCA error source structure.

Note: System firmware must ensure that each set of GHES_ASSIST structures is laid out sequentially in system memory, so that OSPM may consume them as specified by the *Index* formula described above.

ACPI SOURCE LANGUAGE (ASL) REFERENCE

This section formally defines the ACPI Source Language (ASL). ASL is a source language for defining ACPI objects including writing ACPI control methods. OEMs and platform firmware developers define objects and write control methods in ASL and then use a translator tool (compiler) to generate ACPI Machine Language (AML) versions of the control methods. For a formal definition of AML, see the *ACPI Machine Language (AML) Specification* chapter.

AML and ASL are different languages though they are closely related.

Every ACPI-compatible OS must support AML. A given user can define some arbitrary source language (to replace ASL) and write a tool to translate it to AML.

An OEM or platform firmware vendor needs to write ASL and be able to single-step AML for debugging. (Debuggers and similar tools are expected to be AML-level tools, not source-level tools.) An ASL translator implementer must understand how to read ASL and generate AML. An AML interpreter author must understand how to execute AML.

This section has two parts:

- The ASL grammar, which is the formal ASL specification and also serves as a quick reference.
- A full ASL reference, which includes for each ASL operator: the operator invocation syntax, the type of each argument, and a description of the action and use of the operator.

19.1 ASL 2.0 Symbolic Operators and Expressions

For the math and logical operations, ASL supports standard symbolic operators and expressions that are similar to the C language. Compound assignment operators are also supported. The AML code that is generated from the symbolic operators and expressions is identical to the AML code generated for the equivalent legacy ASL operators.

The tables below summarize the ASL 2.0 support for symbolic operators, compared to the legacy ASL equivalent.

Math operators

ASL 2.0 Syntax	Legacy ASL Equivalent
Z = X + Y	Add (X, Y, Z)
Z = X / Y	Divide (X, Y, , Z)
Z = X % Y	Mod (X, Y, Z)
Z = X * Y	Multiply (X, Y, Z)
Z = X - Y	Subtract (X, Y, Z)
Z = X << Y	ShiftLeft (X, Y, Z)
Z = X >> Y	ShiftRight (X, Y, Z)
Z = X & Y	And (X, Y, Z)
Z = X Y	Or (X, Y, Z)
Z = X ^ Y	Xor (X, Y, Z)
Z = ~X	Not (X, Z)
X++	Increment (X)
X--	Decrement (X)

Logical operators

ASL 2.0 Syntax	Legacy ASL Equivalent
(X == Y)	LEqual (X, Y)
(X != Y)	LNotEqual (X, Y)
(X < Y)	LLess (X, Y)
(X > Y)	LGreater (X, Y)
(X <= Y)	LLessEqual (X, Y)
(X >= Y)	LGreaterEqual (X, Y)
(X && Y)	LAnd (X, Y)
(X Y)	LOr (X, Y)
!X	LNot (X)

Assignment and Compound Assignment operations

ASL 2.0 Syntax	Legacy ASL Equivalent
X = Y	Store (Y, X)
X += Y	Add (X, Y, X)
X /= Y	Divide (X, Y, , X)
X %= Y	Mod (X, Y, X)
X *= Y	Multiply (X, Y, X)
X -= Y	Subtract (X, Y, X)
X <<= Y	ShiftLeft (X, Y, X)
X >>= Y	ShiftRight (X, Y, X)
X &= Y	And (X, Y, X)
X = Y	Or (X, Y, X)
X ^= Y	Xor (X, Y, X)

Miscellaneous

ASL 2.0 Syntax	Legacy ASL Equivalent
Z = X[Y]	Index (X, Y, Z)

19.2 ASL Language Grammar

The purpose of this section is to unambiguously state the grammar rules used by the syntax checker of an ASL compiler.

ASL statements declare objects. Each object has three parts, one of which is required and two of which are optional:

```
Object := ObjectType FixedList VariableList
```

FixedList refers to a list, of known length, that supplies data that all instances of a given ObjectType must have. A fixed list is written as (a , b , c , ...) where the number of arguments depends on the specific ObjectType, and some elements can be nested objects, that is (a, b, (q, r, s, t), d). Arguments to a FixedList can have default values, in which case they can be skipped. Thus, (a,,c) will cause the default value for the second argument to be used. Some ObjectTypes can have a null FixedList, which is simply omitted. Trailing arguments of some object types can be left out of a fixed list, in which case the default value is used.

VariableList refers to a list, not of predetermined length, of child objects that help define the parent. It is written as { x, y, z, aa, bb, cc } where any argument can be a nested object. ObjectType determines what terms are legal elements of the VariableList. Some ObjectTypes may have a null variable list, which is simply omitted.

Other rules for writing ASL statements are the following:

- Multiple blanks are the same as one. Blank, (,), ‘ , ’ and newline are all token separators.
- // marks the beginning of a comment, which continues from the // to the end of the line.
- /* marks the beginning of a comment, which continues from the /* to the next */.
- “” (quotes) surround an ASCII string.
- Numeric constants can be written in three ways: ordinary decimal, octal (using 0ddd) or hexadecimal, using the notation 0xdd.
- Nothing indicates an empty item. For example, { Nothing } is equivalent to {}.

19.2.1 ASL Grammar Notation

The notation used to express ASL grammar is specified in the following table.

Table 19.1: ASL Grammar Notation

Notation Convention	Description	Example
Term := Term Term ...	The term to the left of := can be expanded into the sequence of terms on the right.	aterm := bterm cterm means that aterm can be expanded into the two-term sequence of bterm followed by cterm.
Angle brackets (<>)	used to group items.	<a b> <c d> means either a b or c d.
Arrow (=>)	Indicates required run-time reduction of an ASL argument to an AML data type. Means “reduces to” or “evaluates to” at run-time.	“TermArg => Integer” means that the argument must be an ASL TermArg that must resolve to an Integer data type when it is evaluated by an AML interpreter.

continues on next page

Table 19.1 – continued from previous page

Notation Convention	Description	Example
Bar symbol ()	Separates alternatives.	<p>aterm := bterm <cterm dterm> means the following constructs are possible:</p> <p style="padding-left: 40px;">bterm</p> <p style="padding-left: 40px;">cterm dterm</p> <p>aterm := <bterm cterm> dterm means the following constructs are possible:</p> <p style="padding-left: 40px;">bterm dterm</p> <p style="padding-left: 40px;">cterm dterm</p>
Term Term Term	Terms separated from each other by spaces form an ordered list.	N/A
Word in bold	Denotes the name of a term in the ASL grammar, representing any instance of such a term. ASL terms are not case-sensitive.	In the following ASL term definition: ThermalZone (ZoneName) {TermList} the item in bold is the name of the term.
Word in italics	Names of arguments to objects that are replaced for a given instance.	In the following ASL term definition: ThermalZone (ZoneName) {TermList} the italicized item is an argument. The item that is not bolded or italicized is defined elsewhere in the ASL grammar.
Single quotes (‘ ’)	Indicate constant characters.	‘A’
0xdd	Refers to a byte value expressed as two hexadecimal digits.	0x21 means a value of hexadecimal 21, or decimal 37. Notice that a value expressed in hexadecimal must start with a leading zero (0).
Dash character (-)	Indicates a range.	1-9 means a single digit in the range 1 to 9 inclusive.

19.2.2 ASL Name and Pathname Terms

// Name and path characters supported

LeadNameChar := ‘A’-‘Z’ | ‘a’-‘z’ | ‘_’

DigitChar := ‘0’-‘9’

NameChar := *DigitChar* | *LeadNameChar*

RootChar := ‘^’

ParentPrefixChar := ‘^’

PathSeparatorChar := ‘.’

CommaChar := ‘,’

SemicolonDelimiter := Nothing | ‘;’

// Names and paths

NameSeg :=

<*LeadNameChar*> |

<*LeadNameChar* *NameChar*> |

```

    <LeadNameChar NameChar NameChar> |
    <LeadNameChar NameChar NameChar NameChar>
NameString := <RootChar NamePath> | <ParentPrefixChar PrefixPath NamePath> | NonEmpty-
    NamePath
NamePath := Nothing | <NameSeg NamePathTail>
NamePathTail := Nothing | <PathSeparatorChar NameSeg NamePathTail>
NonEmptyNamePath := NameSeg | <NameSeg NamePathTail>
PrefixPath := Nothing | <ParentPrefixChar PrefixPath>

```

19.2.3 ASL Root and Secondary Terms

// Root Terms

```

ASLCode := DefinitionBlockList
DefinitionBlockList := DefinitionBlockTerm | <DefinitionBlockTerm DefinitionBlockList>

```

// Major Terms

```

SuperName := NameString | ArgTerm | LocalTerm | DebugTerm | ReferenceTypeOpcode | MethodInvo-
    cationTerm
Target := Nothing | SuperName
TermArg := ExpressionOpcode | DataObject | ArgTerm | LocalTerm | NameString | SymbolicExpression
MethodInvocationTerm :=
    NameString ( // NameString => Method
        ArgList
    ) => Nothing | DataRefObject

```

// List Terms

```

ArgList := Nothing | <TermArg ArgListTail>
ArgListTail := Nothing | <CommaChar TermArg ArgListTail>
ByteList := Nothing | <ByteConstExpr ByteListTail>
ByteListTail := Nothing | <CommaChar ByteConstExpr ByteListTail>
DWordList := Nothing | <DwordConstExpr DwordListTail>
DWordListTail := Nothing | <CommaChar DwordConstExpr DwordListTail>
ExtendedAccessAttribTerm :=
    ExtendedAccessAttribKeyword (
        AccessLength //ByteConst
    )
FieldUnitList := Nothing | <FieldUnit FieldUnitListTail>
FieldUnitListTail := Nothing | <CommaChar FieldUnit FieldUnitListTail>
FieldUnit := FieldUnitEntry | OffsetTerm | AccessAsTerm | ConnectionTerm
FieldUnitEntry := <Nothing | NameSeg> CommaChar Integer
PackageList := Nothing | <PackageElement PackageListTail>

```

PackageListTail := Nothing | *<CommaChar PackageElement PackageListTail>*
PackageElement := *DataObject* | *NameString*
ParameterTypePackage := *ObjectTypeKeyword* | {Nothing | *ParameterTypePackageList*}
ParameterTypePackageList := *ObjectTypeKeyword* | *<ObjectTypeKeyword CommaChar ParameterTypePackageList>*
ParameterTypesPackage := *ObjectTypeKeyword* | {Nothing | *ParameterTypesPackageList*}
ParameterTypesPackageList := *ParameterTypePackage* | *<ParameterTypePackage CommaChar ParameterTypesPackageList>*
TermList := Nothing | *<Term SemiColonDelimiter TermList>*
Term := *Object* | *StatementOpcode* | *ExpressionOpcode* | *SymbolicExpression*
Object := *CompilerDirective* | *NamedObject* | *NameSpaceModifier*

// Conditional Execution List Terms

CaseTermList := Nothing | *CaseTerm* | *DefaultTerm DefaultTermList* | *CaseTerm CaseTermList*
DefaultTermList := Nothing | *CaseTerm* | *CaseTerm DefaultTermList*
IfExistsTerm := *IfTerm ElseTerm*

19.2.4 ASL Data and Constant Terms

// Numeric Value Terms

LeadDigitChar := '1'-'9'
HexDigitChar := *DigitChar* | 'A'-'F' | 'a'-'f'
OctalDigitChar := '0'-'7'
NullChar := 0x00

// Data Terms

BufferData := *BufferTypeOpcode* | *BufferTerm*
ComputationalData := *BufferData* | *IntegerData* | *StringData*
DataObject := *BufferData* | *PackageData* | *IntegerData* | *StringData*
DataRefObject := *DataObject* | *ObjectReference*
IntegerData := *IntegerTypeOpcode* | *Integer* | *ConstTerm*
PackageData := *PackageTerm*
StringData := *StringTypeOpcode* | *String*

// Integer Terms

Integer := *DecimalConst* | *OctalConst* | *HexConst*
DecimalConst := *LeadDigitChar* | *<DecimalConst DigitChar>*
OctalConst := '0' | *<OctalConst OctalDigitChar>*
HexConst := *<0x HexDigitChar>* | *<0X HexDigitChar>* | *<HexConst HexDigitChar>*
ByteConst := *Integer* => 0x00-0xFF
WordConst := *Integer* => 0x0000-0xFFFF

DWordConst := Integer => 0x00000000-0xFFFFFFFF
QWordConst := Integer => 0x0000000000000000-0xFFFFFFFFFFFFFFFF
ByteConstExpr := <IntegerTypeOpcode | ConstExprTerm | Integer> => ByteConst
WordConstExpr := <IntegerTypeOpcode | ConstExprTerm | Integer> => WordConst
DWordConstExpr := <IntegerTypeOpcode | ConstExprTerm | Integer> => DWordConst
QWordConstExpr := <IntegerTypeOpcode | ConstExprTerm | Integer> => QWordConst
ConstTerm := ConstExprTerm | Revision
ConstExprTerm := Zero | One | Ones

// String Terms

String := "" Utf8CharList ""
Utf8CharList := Nothing | <EscapeSequence Utf8CharList> | <Utf8Char Utf8CharList>
Utf8Char := 0x01-0x21 | 0x23-0x5B | 0x5D-0x7F | 0xC2-0xDF 0x80-0xBF | 0xE0 0xA0-0xBF 0x80-0xBF | 0xE1-0xEC 0x80-0xBF 0x80-0xBF | 0xED 0x80-0x9F 0x80-0xBF | 0xEE-0xEF 0x80-0xBF 0x80-0xBF | 0xF0 0x90-0xBF 0x80-0xBF 0x80-0xBF | 0xF1-0xF3 0x80-0xBF 0x80-0xBF 0x80-0xBF

// Escape sequences

EscapeSequence := SimpleEscapeSequence | OctalEscapeSequence | HexEscapeSequence
HexEscapeSequence := \x HexDigitChar | \x HexDigitChar HexDigitChar
SimpleEscapeSequence := \' | \" | \a | \b | \f | \n | \r | \t | \v | \
OctalEscapeSequence := \ OctalDigitChar | \ OctalDigitChar OctalDigitChar | \ OctalDigitChar OctalDigitChar OctalDigitChar

// Miscellaneous Data Type Terms

ObjectReference := Integer
Boolean := True | False
True := Ones
False := Zero

// Symbolic Operator terms

Operators := '+' | '-' | '*' | '/' | '%' | '&' | '|' | '^' | '~' | '<' | '>' | '!' | '='
CompoundOperators := "<<" | ">>" | "++" | "--" | "==" | "!=" | "<=" | ">=" | "&&" | "||" | "+=" | "-=" | "*=" | "/=" | "%=" | "<<=" | ">>=" | "&=" | "==" | "^="

19.2.5 ASL Opcode Terms

CompilerDirective := IncludeTerm | ExternalTerm
NamedObject := BankFieldTerm | CreateBitFieldTerm | CreateByteFieldTerm | CreateDWordFieldTerm | CreateFieldTerm | CreateQWordFieldTerm | CreateWordFieldTerm | DataRegionTerm | DeviceTerm | EventTerm | FieldTerm | FunctionTerm | IndexFieldTerm | MethodTerm | MutexTerm | OpRegionTerm | PowerResTerm | ProcessorTerm | ThermalZoneTerm
NameSpaceModifier := AliasTerm | NameTerm | ScopeTerm

SymbolicExpressionTerm := (*TermArg*) | *AddSymbolicTerm* | *AndSymbolicTerm* | *DecSymbolicTerm* | *DivideSymbolicTerm* | *IncSymbolicTerm* | *LAndSymbolicTerm* | *LEqualSymbolicTerm* | *LGreaterEqualSymbolicTerm* | *LGreaterSymbolicTerm* | *LLessEqualSymbolicTerm* | *LLessSymbolicTerm* | *LNotEqualSymbolicTerm* | *LNotSymbolicTerm* | *LOrSymbolicTerm* | *ModSymbolicTerm* | *MultiplySymbolicTerm* | *NotSymbolicTerm* | *OrSymbolicTerm* | *ShiftLeftSymbolicTerm* | *ShiftRightSymbolicTerm* | *SubtractSymbolicTerm* | *XorSymbolicTerm*

SymbolicAssignmentTerm := *StoreSymbolicTerm* | *AddCompoundTerm* | *AndCompoundTerm* | *DivideCompoundTerm* | *ModCompoundTerm* | *MultiplyCompoundTerm* | *OrCompoundTerm* | *ShiftLeftCompoundTerm* | *ShiftRightCompoundTerm* | *SubtractCompoundTerm* | *XorCompoundTerm*

StatementOpcode := *BreakTerm* | *BreakPointTerm* | *ContinueTerm* | *FatalTerm* | *ForTerm* | *IfElseTerm* | *NoOpTerm* | *NotifyTerm* | *ReleaseTerm* | *ResetTerm* | *ReturnTerm* | *SignalTerm* | *SleepTerm* | *StallTerm* | *SwitchTerm* | *UnloadTerm* | *WhileTerm*

A statement opcode term does not return a value and can only be used standalone on a line of ASL code. Since these opcodes do not return a value, they cannot be used as a term in an expression.

ExpressionOpcode := *AcquireTerm* | *AddTerm* | *AndTerm* | *ConcatTerm* | *ConcatResTerm* | *CondRefOfTerm* | *CopyObjectTerm* | *DecTerm* | *DerefOfTerm* | *DivideTerm* | *FindSetLeftBitTerm* | *FindSetRightBitTerm* | *FprintfTerm* | *FromBCDTerm* | *IncTerm* | *IndexTerm* | *LAndTerm* | *LEqualTerm* | *LGreaterTerm* | *LGreaterEqualTerm* | *LLessTerm* | *LLessEqualTerm* | *LNotTerm* | *LNotEqualTerm* | *LOrTerm* | *MatchTerm* | *MidTerm* | *ModTerm* | *MultiplyTerm* | *NAndTerm* | *NOrTerm* | *NotTerm* | *ObjectTypeTerm* | *OrTerm* | *PrintfTerm* | *RefOfTerm* | *ShiftLeftTerm* | *ShiftRightTerm* | *SizeOfTerm* | *StoreTerm* | *SubtractTerm* | *TimerTerm* | *ToBCDTerm* | *ToBufferTerm* | *ToDecimalStringTerm* | *ToHexStringTerm* | *ToIntegerTerm* | *ToStringTerm* | *WaitTerm* | *XorTerm* | *MethodInvocationTerm* | *SymbolicExpressionTerm* | *SymbolicAssignmentTerm*

An expression opcode returns a value and can be used in an expression.

IntegerTypeOpcode := *AddTerm* | *AndTerm* | *DecTerm* | *DerefOfTerm* | *DivideTerm* | *EISAIDTerm* | *FindSetLeftBitTerm* | *FindSetRightBitTerm* | *FromBCDTerm* | *IncTerm* | *LAndTerm* | *LEqualTerm* | *LGreaterTerm* | *LGreaterEqualTerm* | *LLessTerm* | *LLessEqualTerm* | *LNotTerm* | *LNotEqualTerm* | *MatchTerm* | *ModTerm* | *MultiplyTerm* | *NAndTerm* | *NOrTerm* | *NotTerm* | *OrTerm* | *ShiftLeftTerm* | *ShiftRightTerm* | *SubtractTerm* | *ToBCDTerm* | *ToIntegerTerm* | *XorTerm* | *SymbolicExpressionTerm*

Integer opcodes are a subset of expression opcodes that return an Integer value and can be used in an expression that evaluates to a constant. These opcodes may be evaluated at ASL compile-time. To ensure that these opcodes will evaluate to a constant, the following rules apply: The term cannot have a destination (target) operand, and must have either an IntegerTypeOpcode, StringTypeOpcode, BufferTypeOpcode, ConstExprTerm, Integer, BufferTerm, Package, or String for all arguments.

StringTypeOpcode := *ConcatTerm* | *DerefOfTerm* | *FprintfTerm* | *MidTerm* | *PrintfTerm* | *ToDecimalStringTerm* | *ToHexStringTerm* | *ToStringTerm*

String type opcodes are a subset of expression opcodes that return a String value and can be used in an expression that evaluates to a constant. These opcodes may be evaluated at ASL compile-time. To ensure that these opcodes will evaluate to a constant, the following rules apply: The term cannot have a destination (target) operand, and must have either an IntegerTypeOpcode, StringTypeOpcode, BufferTypeOpcode, ConstExprTerm, Integer, BufferTerm, Package, or String for all arguments.

BufferTypeOpcode := *ConcatTerm* | *ConcatResTerm* | *DerefOfTerm* | *MidTerm* | *ResourceTemplateTerm* | *ToBufferTerm* | *ToPLDTerm* | *ToUUIDTerm* | *UnicodeTerm*

Buffer type opcodes are a subset of expression opcodes that return a Buffer value and can be used in an expression that evaluates to a constant. These opcodes may be evaluated at ASL compile-time. To ensure that these opcodes will evaluate to a constant, the following rules apply: The term cannot have a destination (target) operand, and must have either an IntegerTypeOpcode, StringTypeOpcode, BufferTypeOpcode, ConstExprTerm, Integer, BufferTerm, Package, or String for all arguments.

ReferenceTypeOpcode := *RefOfTerm* | *DerefOfTerm* | *IndexTerm* | *IndexSymbolicTerm* | UserTermObj

Reference type opcodes are a subset of expression opcodes that return a Reference value and can be used in an expression. They cannot be evaluated at compile time. Reference type also includes the UserTerm, which is a control method invocation.

19.2.6 ASL Primary (Terminal) Terms

AccessAsTerm :=

```
AccessAs (
    AccessType, // AccessTypeKeyword
    AccessAttribute // Nothing | ByteConstExpr | AccessAttribKeyword |
    ExtendedAccessAttribTerm
)
```

AcquireTerm :=

```
Acquire (
    SyncObject, // SuperName => Mutex
    TimeoutValue // WordConstExpr
) => Boolean // True means the operation timed out and the Mutex was not acquired
```

AddCompoundTerm := Addend1-Result // TermArg => Integer => Target += Addend2 // TermArg => Integer => Integer

AddSymbolicTerm := Addend1 // TermArg => Integer + Addend2 // TermArg => Integer => Integer

AddTerm :=

```
Add (
    Addend1, // TermArg => Integer
    Addend2, // TermArg => Integer
    Result // Target
) => Integer
```

AliasTerm :=

```
Alias (
    SourceObject, // NameString
    AliasObject // NameString
)
```

AndCompoundTerm :=

```
Source1-Result // TermArg => Integer => Target
&=
Source2 // TermArg => Integer
=> Integer
```

AndSymbolicTerm :=

```
Source1 // TermArg => Integer
&
Source2 // TermArg => Integer
=> Integer
```

AndTerm :=

```

And (
    Source1, // TermArg => Integer
    Source2, // TermArg => Integer
    Result // Target
) => Integer

ArgTerm := Arg0 | Arg1 | Arg2 | Arg3 | Arg4 | Arg5 | Arg6

BankFieldTerm :=
    BankField (
        RegionName, // NameString => OperationRegion
        BankName, // NameString => FieldUnit
        BankValue, // TermArg => Integer
        AccessType, // AccessTypeKeyword
        LockRule, // LockRuleKeyword
        UpdateRule // UpdateRuleKeyword
    ) { FieldUnitList }

BreakPointTerm := BreakPoint

BreakTerm := Break

BufferTerm :=
    Buffer (
        BuffSize // Nothing | TermArg => Integer
    ) { StringData | ByteList } => Buffer

CaseTerm :=
    Case (
        Value // DataObject
    ) { TermList }

ConcatResTerm :=
    ConcatenateResTemplate (
        Source1, // TermArg => Buffer
        Source2, // TermArg => Buffer
        Result // Target
    ) => Buffer

ConcatTerm :=
    Concatenate (
        Source1, // TermArg => SuperName
        Source2, // TermArg => SuperName
        Result // Target
    ) => Buffer | String

ConnectionTerm :=
    Connection (
        ConnectionResource // NameString | ResourceMacroTerm
    )

CondRefOfTerm :=

```

```

CondRefOf (
    Source // NameString | ArgTerm | LocalTerm | DerefOfTerm
    Destination // Target
) => Boolean

ContinueTerm := Continue

CopyObjectTerm :=
CopyObject (
    Source, // TermArg => DataRefObject
    Result, // NameString | LocalTerm | ArgTerm
) => DataRefObject

CreateBitFieldTerm :=
CreateBitField (
    SourceBuffer, // TermArg => Buffer
    BitIndex, // TermArg => Integer
    BitFieldName // NameString
)

CreateByteFieldTerm :=
CreateByteField (
    SourceBuffer, // TermArg => Buffer
    ByteIndex, // TermArg => Integer
    ByteFieldName // NameString
)

CreateDWordFieldTerm :=
CreateDWordField (
    SourceBuffer, // TermArg => Buffer
    ByteIndex, // TermArg => Integer
    DWordFieldName // NameString
)

CreateFieldTerm :=
CreateField (
    SourceBuffer, // TermArg => Buffer
    BitIndex, // TermArg => Integer
    NumBits, // TermArg => Integer
    FieldName // NameString
)

CreateQWordFieldTerm :=
CreateQWordField (
    SourceBuffer, // TermArg => Buffer
    ByteIndex, // TermArg => Integer
    QWordFieldName // NameString
)

CreateWordFieldTerm :=

```

```

CreateWordField (
    SourceBuffer, // TermArg => Buffer
    ByteIndex, // TermArg => Integer
    WordFieldName // NameString
)

DataRegionTerm :=
    DataTableRegion (
        RegionName, // NameString
        SignatureString, // TermArg => String
        OemIDString, // TermArg => String
        OemTableIDString // TermArg => String
    )

DebugTerm := Debug

DecSymbolicTerm :=
    Minuend // SuperName => Integer
    -
    => Integer

DecTerm :=
    Decrement (
        Minuend // SuperName
    ) => Integer

DefaultTerm := Default {TermList}

DefinitionBlockTerm := | DefinitionBlock ( | AMLFileName, // String | TableSignature, // String | ComplianceRevision, // ByteConst | OEMID, // String | TableID, // String | OEMRevision // DWordConst | ) {TermList}

DerefOfTerm := | DerefOf ( | Source // NameString | ArgTerm | LocalTerm | RefOfTerm | CondRefOfTerm | | IndexTerm | MethodInvocationTerm | ) => DataRefObject

DeviceTerm := | Device ( | DeviceName // NameString | ) {TermList}

DivideCompoundTerm := | Dividend-Result // TermArg => Integer => Target | /= | Divisor // TermArg => Integer | => Integer

DivideSymbolicTerm :=
    Dividend // TermArg => Integer
    /
    Divisor // TermArg => Integer
    => Integer

DivideTerm :=
    Divide (
        Dividend, // TermArg => Integer
        Divisor, // TermArg => Integer
        Remainder, // Target
        Result // Target
    ) => Integer // Returns Result

```

```

EISAIDTerm :=
    EISAID (
        EisaIdString // StringData
    ) => DWordConst

ElseIfTerm :=
    ElseIf (
        Predicate // TermArg => Integer
    ) {TermList} ElseTerm

ElseTerm := Else {TermList} | ElseIfTerm | Nothing

EventTerm :=
    Event (
        EventName // NameString
    )

ExternalTerm :=
    External (
        ObjName, // NameString
        ObjType, // Nothing | ObjectTypeKeyword
        ResultType, // Nothing | ParameterTypePackage
        ParameterTypes // Nothing | ParameterTypesPackage
    )

FatalTerm :=
    Fatal (
        Type, // ByteConstExpr
        Code, // DWordConstExpr
        Arg // TermArg => Integer
    )

FieldTerm :=
    Field (
        RegionName, // NameString => OperationRegion
        AccessType, // AccessTypeKeyword
        LockRule, // LockRuleKeyword
        UpdateRule // UpdateRuleKeyword
    ) {FieldUnitList}

FindSetLeftBitTerm :=
    FindSetLeftBit (
        Source, // TermArg => Integer
        Result // Target
    ) => Integer

FindSetRightBitTerm :=
    FindSetRightBit (
        Source, // TermArg => Integer
        Result // Target
    )

```

) => Integer

ForTerm :=

```
For (
    Initialize, // Nothing | TermArg => ComputationalData
    Predicate, // Nothing | TermArg => ComputationalData
    Update // Nothing | TermArg => ComputationalData
) {TermList}
```

FprintfTerm :=

```
Fprintf (
    TermArg,
    String,
    PrintfArgList
) => String
```

FromBCDTerm :=

```
FromBCD (
    BCDValue, // TermArg => Integer
    Result // Target
) => Integer
```

FunctionTerm :=

```
Function (
    FunctionName, // NameString
    ReturnType, // Nothing | ParameterTypePackage
    ParameterTypes // Nothing | ParameterTypesPackage
) {TermList}
```

IfTerm :=

```
If (
    Predicate // TermArg => Integer
) {TermList}
```

IncludeTerm :=

```
Include (
    FilePathName // StringData
)
```

IncSymbolicTerm :=

```
Addend // SuperName => Integer
++
=> Integer
```

IncTerm :=

```
Increment (
    Addend // SuperName
) => Integer
```

IndexFieldTerm :=

```

IndexField (
    IndexName, // NameString => FieldUnit
    DataName, // NameString => FieldUnit
    AccessType, // AccessTypeKeyword
    LockRule, // LockRuleKeyword
    UpdateRule // UpdateRuleKeyword
) {FieldUnitList}

```

IndexSymbolicTerm :=

```

Source // TermArg => <string | buffer | packageterm>
[Index] // TermArg => Integer
=> ObjectReference

```

IndexTerm :=

```

Index (
    Source, // TermArg => <string | buffer | packageterm>
    Index, // TermArg => Integer
    Destination // Target
) => ObjectReference

```

LAndSymbolicTerm :=

```

Source1 // TermArg => Integer
&&
Source2 // TermArg => Integer
=> Boolean

```

LAndTerm :=

```

LAnd (
    Source1, // TermArg => Integer
    Source2 // TermArg => Integer
) => Boolean

```

LEqualSymbolicTerm :=

```

Source1 // TermArg => ComputationalData
==
Source2 // TermArg => ComputationalData
=> Boolean

```

LEqualTerm :=

```

LEqual (
    Source1, // TermArg => ComputationalData
    Source2 // TermArg => ComputationalData
) => Boolean

```

LGreaterEqualSymbolicTerm :=

```

Source1 // TermArg => ComputationalData
>=
Source2 // TermArg => ComputationalData
=> Boolean

```

LGreaterEqualTerm :=

```

LGreaterEqual (
    Source1, // TermArg => ComputationalData
    Source2 // TermArg => ComputationalData
) => Boolean

```

LGreaterSymbolicTerm :=

```

Source1 // TermArg => ComputationalData
>
Source2 // TermArg => ComputationalData
=> Boolean

```

LGreaterTerm :=

```

LGreater (
    Source1, // TermArg => ComputationalData
    Source2 // TermArg => ComputationalData
) => Boolean

```

LLessEqualSymbolicTerm :=

```

Source1 // TermArg => ComputationalData
<=
Source2 // TermArg => ComputationalData
=> Boolean

```

LLessEqualTerm :=

```

LLessEqual (
    Source1, // TermArg => ComputationalData
    Source2 // TermArg => ComputationalData
) => Boolean

```

LLessSymbolicTerm :=

```

Source1 // TermArg => ComputationalData
<
Source2 // TermArg => ComputationalData
=> Boolean

```

LLessTerm :=

```

LLess (
    Source1, // TermArg => ComputationalData
    Source2 // TermArg => ComputationalData
) => Boolean

```

LNotEqualTerm :=

```

LNotEqual (
    Source1, // TermArg => ComputationalData
    Source2 // TermArg => ComputationalData
) => Boolean

```

LNotEqualSymbolicTerm :=

```

Source1 // TermArg => ComputationalData

```

```

!=
Source2 // TermArg => ComputationalData
=> Boolean

LNotSymbolicTerm :=
!
Source // TermArg => Integer
=> Boolean

LNotTerm :=
LNot (
    Source, // TermArg => Integer
) => Boolean

LOrSymbolicTerm :=
Source1 // TermArg => Integer
||
Source2 // TermArg => Integer
=> Boolean

LoadTableTerm :=
LoadTable (
    SignatureString, // TermArg => String
    OemIDString, // TermArg => String
    OemTableIDString, // TermArg => String
    RootPathString, // Nothing | TermArg => String
    ParameterPathString, // Nothing | TermArg => String
    ParameterData // Nothing | TermArg => DataRefObject
) => Boolean // True (non-zero) means table was successfully loaded

LoadTerm :=
Load (
    Object, // NameString
    Result // SuperName => Boolean – True (non-zero) // means the table was successfully
    loaded
) => Boolean // True (Ones) means the table was successfully loaded

LocalTerm := Local0 | Local1 | Local2 | Local3 | Local4 | Local5 | Local6 | Local7

LOrTerm :=
LOr (
    Source1, // TermArg => Integer
    Source2 // TermArg => Integer
) => Boolean

MatchTerm :=
Match (
    SearchPackage, // TermArg => Package
    Op1, // MatchOpKeyword
    MatchObject1, // TermArg => ComputationalData

```

```

    Op2, // MatchOpKeyword
    MatchObject2, // TermArg => ComputationalData
    StartIndex // TermArg => Integer
) => <ones | integer>

```

MethodTerm :=

```

Method (
    MethodName, // NameString
    NumArgs, // Nothing | ByteConstExpr
    SerializeRule, // Nothing | SerializeRuleKeyword
    SyncLevel, // Nothing | ByteConstExpr
    ReturnType, // Nothing | ParameterTypePackage
    ParameterTypes // Nothing | ParameterTypesPackage
) {TermList}

```

MidTerm :=

```

Mid (
    Source, // TermArg => <buffer | String>
    Index, // TermArg => Integer
    Length, // TermArg => Integer
    Result // Target
) => <buffer | string>

```

ModCompoundTerm :=

```

Dividend-Result // TermArg => Integer => Target
%=
Divisor // TermArg => Integer
=> Integer

```

ModSymbolicTerm :=

```

Dividend // TermArg => Integer
%
Divisor // TermArg => Integer
=> Integer

```

ModTerm :=

```

Mod (
    Dividend, // TermArg => Integer
    Divisor, // TermArg => Integer
    Result // Target
) => Integer // Returns Result

```

MultiplyCompoundTerm :=

```

Multiplicand-Result // TermArg => Integer => Target
*=
Multiplier // TermArg => Integer
=> Integer

```

MultiplySymbolicTerm :=

```

Multiplicand // TermArg => Integer

```

```

*
Multiplier // TermArg => Integer
=> Integer

MultiplyTerm :=
Multiply (
    Multiplicand, // TermArg => Integer
    Multiplier, // TermArg => Integer
    Result // Target
) => Integer

MutexTerm :=
Mutex (
    MutexName, // NameString
    SyncLevel // ByteConstExpr
)

NameTerm :=
Name (
    ObjectName, // NameString
    Object // DataObject
)

NAndTerm :=
NAnd (
    Source1, // TermArg => Integer
    Source2, // TermArg => Integer
    Result // Target
) => Integer

NoOpTerm := NoOp

NOrTerm :=
NOr (
    Source1, // TermArg => Integer
    Source2, // TermArg => Integer
    Result // Target
) => Integer

NotifyTerm :=
Notify (
    Object, // SuperName => <thermalzone | processor | device>
    NotificationValue // TermArg => Integer
)

NotSymbolicTerm :=
~
Source // TermArg => Integer
=> Integer

NotTerm :=

```

```
Not (
    Source, // TermArg => Integer
    Result // Target
) => Integer
```

ObjectTypeTerm :=

```
ObjectType (
    Object // NameString | ArgTerm | LocalTerm | DebugTerm |
    // RefOfTerm | DerefOfTerm | IndexTerm
) => Integer
```

OffsetTerm :=

```
Offset (
    ByteOffset // IntegerData
)
```

OpRegionTerm :=

```
OperationRegion (
    RegionName, // NameString
    RegionSpace, // RegionSpaceKeyword
    Offset, // TermArg => Integer
    Length // TermArg => Integer
)
```

OrCompoundTerm :=

```
Source1-Result // TermArg => Integer => Target
|=
Source2 // TermArg => Integer
=> Integer
```

OrSymbolicTerm :=

```
Source1 // TermArg => Integer
|
Source2 // TermArg => Integer
=> Integer
```

OrTerm :=

```
Or (
    Source1, // TermArg => Integer
    Source2, // TermArg => Integer
    Result // Target
) => Integer
```

PackageTerm :=

```
Package (
    NumElements // Nothing | ByteConstExpr | TermArg => Integer
) {PackageList} => Package
```

```
PLDKeyword := PLD_Revision | PLD_IgnoreColor | PLD_Red | PLD_Green | PLD_Blue | PLD_Width
| PLD_Height | PLD_UserVisible | PLD_Dock | PLD_Lid | PLD_Panel | PLD_VerticalPosition
```

| PLD_HorizontalPosition | PLD_Shape | PLD_GroupOrientation | PLD_GroupToken |
 PLD_GroupPosition | PLD_Bay | PLD_Ejectable | PLD_EjectRequired | PLD_CabinetNumber

PLDKeywordList := PLDKeyword = StringDataPLD_Revision | PLDKeyword = IntegerData-
 PLD_Revision | PLDKeyword = StringDataPLD_Revision, PLDKeywordListPLD_Revision, PLD-
 Keyword = IntegerDataPLD_Revision, PLDKeywordListPLD_Revision

PowerResTerm :=

PowerResource (
 ResourceName, // *NameString*
 SystemLevel, // *ByteConstExpr*
 ResourceOrder // *WordConstExpr*
) {TermList}

PrintfArgList := *TermArg* | *TermArg* , *PrintfArgList*

PrintfTerm :=

Printf (
 String,
 PrintfArgList
) => String

ProcessorTerm :=

Processor (
 ProcessorName, // *NameString*
 ProcessorID, // *ByteConstExpr*
 PBlockAddress, // *DWordConstExpr* | Nothing (=0)
 PblockLength // *ByteConstExpr* | Nothing (=0)
) {TermList}

RawDataBufferTerm :=

RawDataBuffer (
 BuffSize // Nothing | *WordConst*
) { ByteList } => RawDataBuffer

RefOfTerm :=

RefOf (
 Source // *NameString* | *ArgTerm* | *LocalTerm* | *DerefOfTerm*
) => ObjectReference

ReleaseTerm :=

Release (
 SyncObject // *SuperName*
)

ResetTerm :=

Reset (
 SyncObject // *SuperName*
)

ReturnTerm :=

Return (

```

        Arg // Nothing | TermArg => DataRefObject
    )
ScopeTerm :=
    Scope (
        Location // NameString
    ) { TermList }
ShiftLeftCompoundTerm :=
    Source-Result // TermArg => Integer => Target
    <<=
    ShiftCount // TermArg => Integer
    => Integer
ShiftLeftSymbolicTerm :=
    Source // TermArg => Integer
    <<
    ShiftCount // TermArg => Integer
    => Integer
ShiftLeftTerm :=
    ShiftLeft (
        Source, // TermArg => Integer
        ShiftCount, // TermArg => Integer
        Result // Target
    ) => Integer
ShiftRightCompoundTerm :=
    Source-Result // TermArg => Integer => Target
    >>=
    ShiftCount // TermArg => Integer
    => Integer
ShiftRightSymbolicTerm :=
    Source // TermArg => Integer
    >>
    ShiftCount // TermArg => Integer
    => Integer
ShiftRightTerm :=
    ShiftRight (
        Source, // TermArg => Integer
        ShiftCount, // TermArg => Integer
        Result // Target
    ) => Integer
SignalTerm :=
    Signal (
        SyncObject // SuperName
    )

```

SizeOfTerm :=

```
SizeOf (
    DataObject // SuperName => <string | buffer | package>
) => Integer
```

SleepTerm :=

```
Sleep (
    MilliSeconds // TermArg => Integer
)
```

StallTerm :=

```
Stall (
    MicroSeconds // TermArg => Integer
)
```

StoreSymbolicTerm :=

```
Destination // SuperName
=
Source // TermArg => DataRefObject
=> DataRefObject
```

StoreTerm :=

```
Store (
    Source, // TermArg => DataRefObject
    Destination // SuperName
) => DataRefObject
```

SubtractCompoundTerm :=

```
Minuend-Result // TermArg => Integer => Target
- =
Subtrahend // TermArg => Integer
=> Integer
```

SubtractSymbolicTerm :=

```
Minuend // TermArg => Integer
Subtrahend // TermArg => Integer
=> Integer
```

SubtractTerm :=

```
Subtract (
    Minuend, // TermArg => Integer
    Subtrahend, // TermArg => Integer
    Result // Target
) => Integer
```

SwitchTerm :=

```
Switch (
    Predicate // TermArg => ComputationalData
) { CaseTermList }
```

ThermalZoneTerm :=

```
ThermalZone (
    ThermalZoneName // NameString
) { TermList }
```

TimerTerm := Timer => Integer**ToBCDTerm :=**

```
ToBCD (
    Value, // TermArg => Integer
    Result // Target
) => Integer
```

ToBufferTerm :=

```
ToBuffer (
    Data, // TermArg => ComputationalData
    Result // Target
) => ComputationalData
```

ToDecimalStringTerm :=

```
ToDecimalString (
    Data, // TermArg => ComputationalData
    Result // Target
) => String
```

ToHexStringTerm :=

```
ToHexString (
    Data, // TermArg => ComputationalData
    Result // Target
) => String
```

ToIntegerTerm :=

```
ToInteger (
    Data, // TermArg => ComputationalData
    Result // Target
) => Integer
```

ToPLDTerm :=

```
ToPLD (
    PLDKeywordList
) => Buffer
```

ToStringTerm :=

```
ToString (
    Source, // TermArg => Buffer
    Length, // Nothing | TermArg => Integer
    Result // Target
) => String
```

ToUUIDTerm :=

```
ToUUID (
    String // StringData
) => Buffer
```

UnicodeTerm :=

```
Unicode (
    String // StringData
) => Buffer
```

UnloadTerm :=

```
Unload (
    DDBHandle // SuperName
)
```

WaitTerm :=

```
Wait (
    SyncObject, // SuperName => Event
    TimeoutValue // TermArg => Integer
) => Boolean // True means timed-out
```

WhileTerm :=

```
While (
    Predicate // TermArg => Integer
) {TermList}
```

XorCompoundTerm :=

```
Source1-Result // TermArg => Integer => Target
^=
Source2 // TermArg => Integer
=> Integer
```

XorSymbolicTerm :=

```
Source1 // TermArg => Integer
^
Source2 // TermArg => Integer
=> Integer
```

XOrTerm :=

```
XOr (
    Source1, // TermArg => Integer
    Source2, // TermArg => Integer
    Result // Target
) => Integer
```

19.2.7 ASL Parameter Keyword Terms

AccessAttribKeyword := `AttribQuick` | `AttribSendReceive` | `AttribByte` | `AttribBytes (n)` | `AttribRawBytes (n)` | `AttribRawProcessBytes (n)` | `AttribWord` | `AttribBlock` | `AttribProcessCall` | `AttribBlockProcessCall` // Note: Used for SMBus and GenericSerialBus BufferAcc only |

AccessTypeKeyword := `AnyAcc` | `ByteAcc` | `WordAcc` | `DWordAcc` | `QWordAcc` | `BufferAcc`

AddressKeyword := `AddressRangeMemory` | `AddressRangeReserved` | `AddressRangeNVS` | `AddressRangeACPI`

AddressSpaceKeyword := *RegionSpaceKeyword*

AddressingModeKeyword := `AddressingMode7Bit` | `AddressingMode10Bit`

ByteLengthKeyword := `DataBitsFive` | `DataBitsSix` | `DataBitsSeven` | `DataBitsEight` | `DataBitsNine`

BusMasterKeyword := `BusMaster` | `NotBusMaster`

ClockPhaseKeyword := `ClockPhaseFirst` | `ClockPhaseSecond`

ClockPolarityKeyword := `ClockPolarityLow` | `ClockPolarityHigh`

DecodeKeyword := `SubDecode` | `PosDecode`

EndianKeyword := `BigEndianing` | `LittleEndian`

ExtendedAccessAttribKeyword := `AttribBytes` | `AttribRawBytes` | `AttribRawProcessBytes` // Note: Used for GenericSerialBus BufferAcc only.

FlowControlKeyword := `FlowControlNone` | `FlowControlXon` | `FlowControlHardware`

InterruptTypeKeyword := `Edge` | `Level`

InterruptLevel := `ActiveHigh` | `ActiveLow`

InterruptLevelKeyword := `ActiveHigh` | `ActiveLow` | `ActiveBoth`

IODecodeKeyword := `Decode16` | `Decode10`

IoRestrictionKeyword := `IoRestrictionNone` | `IoRestrictionInputOnly` | `IoRestrictionOutputOnly` | `IoRestrictionNoneAndPreserve`

LockRuleKeyword := `Lock` | `NoLock`

MatchOpKeyword := `MTR` | `MEQ` | `MLE` | `MLT` | `MGE` | `MGT`

MaxKeyword := `MaxFixed` | `MaxNotFixed`

MemTypeKeyword := `Cacheable` | `WriteCombining` | `Prefetchable` | `NonCacheable`

MinKeyword := `MinFixed` | `MinNotFixed`

ObjectTypeKeyword := `UnknownObj` | `IntObj` | `StrObj` | `BuffObj` | `PkgObj` | `FieldUnitObj` | `DeviceObj` | `EventObj` | `MethodObj` | `MutexObj` | `OpRegionObj` | `PowerResObj` | `ThermalZoneObj` | `BuffFieldObj`

ParityKeyword := `ParityTypeNone` | `ParityTypeSpace` | `ParityTypeMark` | `ParityTypeOdd` | `ParityTypeEven`

PinConfigKeyword := `PullDefault` | `PullUp` | `PullDown` | `PullNone`

PolarityKeyword := `PolarityHigh` | `PolarityLow`

RangeTypeKeyword := `ISAOnlyRanges` | `NonISAOnlyRanges` | `EntireRange`

ReadWriteKeyword := `ReadWrite` | `ReadOnly`

RegionSpaceKeyword := SystemIO | SystemMemory | PCI_Config | EmbeddedControl | SMBus | SystemCMOS | PciBarTarget | IPMI | GeneralPurposeIO | GenericSerialBus | PCC | PRM | FFixedHW

ResourceTypeKeyword := ResourceConsumer | ResourceProducer

SerializeRuleKeyword := Serialized | NotSerialized

ShareTypeKeyword := Shared | Exclusive | SharedAndWake | ExclusiveAndWake

SlaveModeKeyword := ControllerInitiated | DeviceInitiated

StopBitsKeyword := StopBitsZero | StopBitsOne | StopBitsOnePlusHalf | StopBitsTwo

TransferWidthKeyword := Width8Bit | Width16Bit | Width32Bit | Width64Bit | Width128Bit | Width256Bit

TranslationKeyword := SparseTranslation | DenseTranslation

TypeKeyword := TypeTranslation | TypeStatic

UpdateRuleKeyword := Preserve | WriteAsOnes | WriteAsZeros

UserDefRegionSpace := IntegerData => 0x80 - 0xFF

XferTypeKeyword := Transfer8 | Transfer16 | Transfer8_16

WireModeKeyword := ThreeWireMode | FourWireMode

19.2.8 ASL Resource Template Terms

ResourceMacroList := Nothing | <*resourcemacroterm resourcemacrolist*>

ResourceMacroTerm := *DMA*Term | *DWordIO*Term | *DWordMemory*Term | *DWordSpace*Term | *End-DependentFn*Term | *ExtendedIO*Term | *ExtendedMemory*Term | *ExtendedSpace*Term | *FixedDMA*Term | *FixedIO*Term | *GpioInt*Term | *GpioIO*Term | *I2CSerialBus*Term | *Interrupt*Term | *IO*Term | *IRQNoFlags*Term | *IRQ*Term | *Memory24*Term | *Memory32Fixed*Term | *Memory32*Term | *Pin-Config*Term | *PinFunction*Term | *PinGroup*Term | *PinGroupConfig*Term | *PinGroupFunction*Term | *QWordIO*Term | *QWordMemory*Term | *QWordSpace*Term | *Register*Term | *SPISerialBus*Term | *Start-DependentFn*Term | *StartDependentFnNoPri*Term | *UARTSerialBus*Term | *VendorLong*Term | *VendorShort*Term | *WordBusNumber*Term | *WordIO*Term | *WordSpace*Term

DMATerm :=

```
DMA (
    DMAType, // DMATypeKeyword (_TYP)
    BusMaster, // BusMasterKeyword (_BM)
    XferType, // XferTypeKeyword (_SIZ)
    DescriptorName // Nothing | NameString
) {ByteList} // List of channels (0-7 bytes)
```

DWordIOTerm :=

```
DWordIO (
    ResourceUsage, // Nothing (ResourceConsumer) | ResourceTypeKeyword
    MinType, // Nothing (MinNotFixed) | MinKeyword (_MIF)
    MaxType, // Nothing (MaxNotFixed) | MaxKeyword (_MAF)
    Decode, // Nothing (PosDecode) | DecodeKeyword (_DEC)
    RangeType, // Nothing (EntireRange) | RangeTypeKeyword (_RNG)
    AddressGranularity, // DWordConstExpr (_GRA)
    MinAddress, // DWordConstExpr (_MIN)
```

```

MaxAddress, // DWordConstExpr (_MAX)
AddressTranslation, // DWordConstExpr (_TRA)
AddressLength, // DWordConstExpr (_LEN)
ResourceSourceIndex, // Nothing | ByteConstExpr
ResourceSource, // Nothing | StringData
DescriptorName, // Nothing | NameString
TranslationType, // Nothing | TypeKeyword (_TTP)
TranslationDensity // Nothing | TranslationKeyword (_TRS)
)

```

DWordMemoryTerm :=

```

DWordMemory (
    ResourceUsage, // Nothing (ResourceConsumer) | ResourceTypeKeyword
    Decode, // Nothing (PosDecode) | DecodeKeyword (_DEC)
    MinType, // Nothing (MinNotFixed) | MinKeyword (_MIF)
    MaxType, // Nothing (MaxNotFixed) | MaxKeyword (_MAF)
    MemType, // Nothing (NonCacheable) | MemTypeKeyword (_MEM)
    ReadWriteType, // ReadWriteKeyword (_RW)
    AddressGranularity, // DWordConstExpr (_GRA)
    MinAddress, // DWordConstExpr (_MIN)
    MaxAddress, // DWordConstExpr (_MAX)
    AddressTranslation, // DWordConstExpr (_TRA)
    AddressLength, // DWordConstExpr (_LEN)
    ResourceSourceIndex, // Nothing | ByteConstExpr
    ResourceSource, // Nothing | StringData
    DescriptorName, // Nothing | NameString
    MemoryRangeType, // Nothing | AddressKeyword (_MTP)
    TranslationType // Nothing | TypeKeyword (_TTP)
)

```

DWordSpaceTerm :=

```

DWordSpace (
    ResourceType, // ByteConstExpr (_RT), 0xC0 - 0xFF
    ResourceUsage, // Nothing (ResourceConsumer) | ResourceTypeKeyword
    Decode, // Nothing (PosDecode) | DecodeKeyword (_DEC)
    MinType, // Nothing (MinNotFixed) | MinKeyword (_MIF)
    MaxType, // Nothing (MaxNotFixed) | MaxKeyword (_MAF)
    TypeSpecificFlags, // ByteConstExpr (_TSF)
    AddressGranularity, // DWordConstExpr (_GRA)
    MinAddress, // DWordConstExpr (_MIN)
    MaxAddress, // DWordConstExpr (_MAX)
    AddressTranslation, // DWordConstExpr (_TRA)
    AddressLength, // DWordConstExpr (_LEN)
    ResourceSourceIndex, // Nothing | ByteConstExpr
    ResourceSource, // Nothing | StringData
    DescriptorName // Nothing | NameString
)

```

EndDependentFnTerm := EndDependentFn ()

ExtendedIOTerm :=

```
ExtendedIO (
    ResourceUsage, // Nothing (ResourceConsumer) | ResourceTypeKeyword
    MinType, // Nothing (MinNotFixed) | MinKeyword (_MIF)
    MaxType, // Nothing (MaxNotFixed) | MaxKeyword (_MAF)
    Decode, // Nothing (PosDecode) | DecodeKeyword (_DEC)
    RangeType, // Nothing (EntireRange) | RangeTypeKeyword (_RNG)
    AddressGranularity, // QWordConstExpr (_GRA)
    MinAddress, // QWordConstExpr (_MIN)
    MaxAddress, // QWordConstExpr (_MAX)
    AddressTranslation, // QWordConstExpr (_TRA)
    AddressLength, // QWordConstExpr (_LEN)
    TypeSpecificAttributes, // Nothing | QWordConstExpr
    DescriptorName, // Nothing | NameString
    TranslationType, // Nothing | TypeKeyword (_TTP)
    TranslationDensity // Nothing | TranslationKeyword (_TRS)
)
```

ExtendedMemoryTerm :=

```
ExtendedMemory (
    ResourceUsage, // Nothing (ResourceConsumer) | ResourceTypeKeyword
    Decode, // Nothing (PosDecode) | DecodeKeyword (_DEC)
    MinType, // Nothing (MinNotFixed) | MinKeyword (_MIF)
    MaxType, // Nothing (MaxNotFixed) | MaxKeyword (_MAF)
    MemType, // Nothing (NonCacheable) | MemTypeKeyword (_MEM)
    ReadWriteType, // ReadWriteKeyword (_RW)
    AddressGranularity, // QWordConstExpr (_GRA)
    MinAddress, // QWordConstExpr (_MIN)
    MaxAddress, // QWordConstExpr (_MAX)
    AddressTranslation, // QWordConstExpr (_TRA)
    AddressLength, // QWordConstExpr (_LEN)
    TypeSpecificAttributes, // Nothing | QWordConstExpr
    DescriptorName, // Nothing | NameString
    MemoryRangeType, // Nothing | AddressKeyword (_MTP)
    TranslationType // Nothing | TypeKeyword (_TTP)
)
```

ExtendedSpaceTerm :=

```
ExtendedSpace (
    ResourceType, // ByteConstExpr (_RT), 0xC0 - 0xFF
    ResourceUsage, // Nothing (ResourceConsumer) | ResourceTypeKeyword
    Decode, // Nothing (PosDecode) | DecodeKeyword (_DEC)
    MinType, // Nothing (MinNotFixed) | MinKeyword (_MIF)
    MaxType, // Nothing (MaxNotFixed) | MaxKeyword (_MAF)
    TypeSpecificFlags, // ByteConstExpr (_TSF)
    AddressGranularity, // QWordConstExpr (_GRA)
)
```

```

    MinAddress, // QWordConstExpr (_MIN)
    MaxAddress, // QWordConstExpr (_MAX)
    AddressTranslation, // QWordConstExpr (_TRA)
    AddressLength, // QWordConstExpr (_LEN)
    TypeSpecificAttributes, // Nothing | QWordConstExpr (_ATT)
    DescriptorName // Nothing | NameString
)
FixedDMATerm :=
    FixedDMA (
        DMAReq, // WordConstExpr (_DMA)
        Channel, // WordConstExpr (_TYP)
        XferWidth, // Nothing (Width32Bit) | TransferWidthKeyword (_SIZ)
        DescriptorName, // Nothing | NameString
    )
FixedIOTerm :=
    FixedIO (
        AddressBase, // WordConstExpr (_BAS)
        RangeLength, // ByteConstExpr (_LEN)
        DescriptorName // Nothing | NameString
    )
GpioIntTerm :=
    GpioInt (
        InterruptType, // InterruptTypeKeyword (_MOD)
        InterruptLevel, // InterruptLevelKeyword (_POL)
        ShareType, // Nothing (Exclusive) | ShareTypeKeyword (_SHR)
        PinConfig, // PinConfigKeyword | ByteConstExpr (_PPI)
        DeBounceTime // Nothing | WordConstExpr (_DBT)
        ResourceSource, // StringData
        ResourceSourceIndex, // Nothing (0) | ByteConstExpr
        ResourceUsage, // Nothing (ResourceConsumer) | ResourceTypeKeyword
        DescriptorName, // Nothing | NameString
        VendorData // Nothing | RawDataBuffer (_VEN)
    ) {DWordList} // List of GPIO pins (_PIN)
GpioIOTerm :=
    GpioIO (
        ShareType, // Nothing (Exclusive) | ShareTypeKeyword (_SHR)
        PinConfig, // PinConfigKeyword | ByteConstExpr (_PPIC)
        DeBounceTime // Nothing | WordConstExpr (_DBT)
        DriveStrength // Nothing | WordConstExpr (_DRS)
        IORestriction // Nothing (None) | IORestrictionKeyword (_IOR)
        ResourceSource, // StringData
        ResourceSourceIndex, // Nothing (0) | ByteConstExpr
        ResourceUsage, // Nothing (ResourceConsumer) | ResourceTypeKeyword
        DescriptorName, // Nothing | NameString

```



```
VendorData // Nothing | RawDataBuffer (_VEN)
) {DWordList} // List of GPIO pins (_PIN)
```

I2CSerialBusTerm :=

```
I2CSerialBusV2 (
  SlaveAddress, // WordConstExpr (_ADR)
  SlaveMode, // Nothing (ControllerInitiated) | SlaveModeKeyword (_SLV)
  ConnectionSpeed, // DWordConstExpr (_SPE)
  AddressingMode, // Nothing (AddressingMode7Bit) | AddressModeKeyword (_MOD)
  ResourceSource, // StringData
  ResourceSourceIndex, // Nothing | ByteConstExpr
  ResourceUsage, // Nothing (ResourceConsumer) | ResourceTypeKeyword
  DescriptorName, // Nothing | NameString
  ShareType, // Nothing (Exclusive) | ShareTypeKeyword (_SHR)
  VendorData // Nothing | RawDataBuffer (_VEN)
)
```

InterruptTerm :=

```
Interrupt (
  ResourceType, // Nothing (ResourceConsumer) | ResourceTypeKeyword
  InterruptType, // InterruptTypeKeyword (_LL, _HE)
  InterruptLevel, // InterruptLevelKeyword (_LL, _HE)
  ShareType, // Nothing (Exclusive) | ShareTypeKeyword (_SHR)
  ResourceSourceIndex, // Nothing | ByteConstExpr
  ResourceSource, // Nothing | StringData
  DescriptorName // Nothing | NameString
) {DWordList} // list of interrupts (_INT)
```

IOTerm :=

```
IO (
  IODecode, // IODecodeKeyword (_DEC)
  MinAddress, // WordConstExpr (_MIN)
  MaxAddress, // WordConstExpr (_MAX)
  Alignment, // ByteConstExpr (_ALN)
  RangeLength, // ByteConstExpr (_LEN)
  DescriptorName // Nothing | NameString
)
```

IRQNoFlagsTerm :=

```
IRQNoFlags (
  DescriptorName // Nothing | NameString
) {ByteList} // list of interrupts (0-15 bytes)
```

IRQTerm :=

```
IRQ (
  InterruptType, // InterruptTypeKeyword (_LL, _HE)
  InterruptLevel, // InterruptLevelKeyword (_LL, _HE)
  ShareType, // Nothing (Exclusive) | ShareTypeKeyword (_SHR)
  DescriptorName // Nothing | NameString
```

) {ByteList} // list of interrupts (0-15 bytes)

Memory24Term :=

```
Memory24 (
    ReadWriteType, // ReadWriteKeyword (_RW)
    MinAddress[23:8], // WordConstExpr (_MIN)
    MaxAddress[23:8], // WordConstExpr (_MAX)
    Alignment, // WordConstExpr (_ALN)
    RangeLength, // WordConstExpr (_LEN)
    DescriptorName // Nothing | NameString
)
```

Memory32FixedTerm :=

```
Memory32Fixed (
    ReadWriteType, // ReadWriteKeyword (_RW)
    AddressBase, // DWordConstExpr (_BAS)
    RangeLength, // DWordConstExpr (_LEN)
    DescriptorName // Nothing | NameString
)
```

Memory32Term :=

```
Memory32 (
    ReadWriteType, // ReadWriteKeyword (_RW)
    MinAddress, // DWordConstExpr (_MIN)
    MaxAddress, // DWordConstExpr (_MAX)
    Alignment, // DWordConstExpr (_ALN)
    RangeLength, // DWordConstExpr (_LEN)
    DescriptorName // Nothing | NameString
)
```

PinConfigTerm :=

```
PinConfig (
    ShareType, // Nothing (Exclusive) | ShareTypeKeyword (_SHR)
    PinConfigType, // ByteData (_TYP)
    PinConfigValue, // ByteData (_VAL)
    ResourceSource, // StringData
    ResourceSourceIndex, // Nothing (0) | ByteConstExpr
    ResourceUsage, // Nothing (ResourceConsumer) | ResourceTypeKeyword
    DescriptorName, // Nothing | NameString
    VendorData // Nothing | RawDataBuffer (_VEN)
) {DWordList} (_PIN)
```

PinFunctionTerm :=

```
PinFunction (
    ShareType, // Nothing (Exclusive) | ShareTypeKeyword (_SHR)
    PinPullConfiguration, // PinConfigKeyword | ByteConstExpr (_PPI)
    FunctionNumber, // WordData
    ResourceSource, // StringData
    ResourceSourceIndex, // Nothing (0) | ByteConstExpr
)
```

```

ResourceUsage, // Nothing (ResourceConsumer) | ResourceTypeKeyword
DescriptorName, // Nothing | NameString
VendorData // Nothing | RawDataBuffer (_VEN)
) {DWordList} (_PIN)

```

PinGroupTerm :=

```

PinGroup (
ResourceLabel, // StringData
ResourceUsage, // Nothing (ResourceConsumer) | ResourceTypeKeyword
DescriptorName, // Nothing | NameString
VendorData // Nothing | RawDataBuffer (_VEN)
) {DWordList} (_PIN)

```

PinGroupConfigTerm :=

```

PinGroupConfig (
ShareType, // Nothing (Exclusive) | ShareTypeKeyword (_SHR)
PinConfigType, // ByteData (_TYP)
PinConfigValue, // ByteData (_VAL)
ResourceSource, // StringData
ResourceSourceIndex, // Nothing (0) | ByteConstExpr
ResourceSourceLabel, // StringData
ResourceUsage, // Nothing (ResourceConsumer) | ResourceTypeKeyword
DescriptorName, // Nothing | NameString
VendorData // Nothing | RawDataBuffer (_VEN)
)

```

PinGroupFunctionTerm :=

```

PinGroupFunction (
ShareType, // Nothing (Exclusive) | ShareTypeKeyword (_SHR)
FunctionNumber, // WordData (_FUN)
ResourceSource, // StringData
ResourceSourceIndex, // Nothing (0) | ByteConstExpr
ResourceSourceLabel, // StringData
ResourceUsage, // Nothing (ResourceConsumer) | ResourceTypeKeyword
DescriptorName, // Nothing | NameString
VendorData // Nothing | RawDataBuffer (_VEN)
)

```

QWordIOTerm :=

```

QWordIO (
ResourceUsage, // Nothing (ResourceConsumer) | ResourceTypeKeyword
MinType, // Nothing (MinNotFixed) | MinKeyword (_MIF)
MaxType, // Nothing (MaxNotFixed) | MaxKeyword (_MAF)
Decode, // Nothing (PosDecode) | DecodeKeyword (_DEC)
RangeType, // Nothing (EntireRange) | RangeTypeKeyword (_RNG)
AddressGranularity, // QWordConstExpr (_GRA)
MinAddress, // QWordConstExpr (_MIN)
MaxAddress, // QWordConstExpr (_MAX)
)

```

```

AddressTranslation, // QWordConstExpr (_TRA)
AddressLength, // QWordConstExpr (_LEN)
ResourceSourceIndex, // Nothing | ByteConstExpr
ResourceSource, // Nothing | StringData
DescriptorName, // Nothing | NameString
TranslationType, // Nothing | TypeKeyword (_TTP)
TranslationDensity // Nothing | TranslationKeyword (_TRS)

```

)

QWordMemoryTerm :=

```

QWordMemory (
    ResourceUsage, // Nothing (ResourceConsumer) | ResourceTypeKeyword
    Decode, // Nothing (PosDecode) | DecodeKeyword (_DEC)
    MinType, // Nothing (MinNotFixed) | MinKeyword (_MIF)
    MaxType, // Nothing (MaxNotFixed) | MaxKeyword (_MAF)
    MemType, // Nothing (NonCacheable) | MemTypeKeyword (_MEM)
    ReadWriteType, // ReadWriteKeyword (_RW)
    AddressGranularity, // QWordConstExpr (_GRA)
    MinAddress, // QWordConstExpr (_MIN)
    MaxAddress, // QWordConstExpr (_MAX)
    AddressTranslation, // QWordConstExpr (_TRA)
    AddressLength, // QWordConstExpr (_LEN)
    ResourceSourceIndex, // Nothing | ByteConstExpr
    ResourceSource, // Nothing | StringData
    DescriptorName, // Nothing | NameString
    MemoryRangeType, // Nothing | AddressKeyword (_MTP)
    TranslationType // Nothing | TypeKeyword (_TTP)

```

)

QWordSpaceTerm :=

```

QWordSpace (
    ResourceType, // ByteConstExpr (_RT), 0xC0 - 0xFF
    ResourceUsage, // Nothing (ResourceConsumer) | ResourceTypeKeyword
    Decode, // Nothing (PosDecode) | DecodeKeyword (_DEC)
    MinType, // Nothing (MinNotFixed) | MinKeyword (_MIF)
    MaxType, // Nothing (MaxNotFixed) | MaxKeyword (_MAF)
    TypeSpecificFlags, // ByteConstExpr (_TSF)
    AddressGranularity, // QWordConstExpr (_GRA)
    MinAddress, // QWordConstExpr (_MIN)
    MaxAddress, // QWordConstExpr (_MAX)
    AddressTranslation, // QWordConstExpr (_TRA)
    AddressLength, // QWordConstExpr (_LEN)
    ResourceSourceIndex, // Nothing | ByteConstExpr
    ResourceSource, // Nothing | StringData
    DescriptorName // Nothing | NameString

```

)

RegisterTerm :=

```
Register (
    AddressSpaceID, // AddressSpaceKeyword (_ASI)
    RegisterBitWidth, // ByteConstExpr (_RBW)
    RegisterOffset, // ByteConstExpr (_RBO)
    RegisterAddress, // QWordConstExpr (_ADR)
    AccessSize, // ByteConstExpr (_ASZ)
    DescriptorName // Nothing | NameString
)
```

SPISerialBusTerm :=

```
SPISerialBusV2 (
    DeviceSelection, // WordConstExpr (_ADR)
    DeviceSelectionPolarity, // Nothing (PolarityLow) |
    DevicePolarityKeyword (_DPL)
    WireMode, // Nothing (FourWireMode) | WireModeKeyword (_MOD)
    DataBitLength, // ByteConstExpr (_LEN)
    SlaveMode, // Nothing (ControllerInitiated) | SlaveModeKeyword (_SLV)
    ConnectionSpeed, // DWordConstExpr (_SPE)
    ClockPolarity, // ClockPolarityKeyword (_POL)
    ClockPhase, // ClockPhaseKeyword (_PHA)
    ResourceSource, // StringData
    ResourceSourceIndex, // Nothing | ByteConstExpr
    ResourceUsage, // Nothing (ResourceConsumer) | ResourceTypeKeyword
    DescriptorName, // Nothing | NameString
    ShareType, // Nothing (Exclusive) | ShareTypeKeyword (_SHR)
    VendorData // Nothing | RawDataBuffer (_VEN)
)
```

StartDependentFnNoPriTerm :=

```
StartDependentFnNoPri () {ResourceMacroList}
```

StartDependentFnTerm :=

```
StartDependentFn (
    CompatPriority, // ByteConstExpr (0-2)
    PerfRobustPriority // ByteConstExpr (0-2)
) {ResourceMacroList}
```

UARTSerialBusTerm :=

```
UARTSerialBusV2(
    Initial BaudRate, // DwordConstExpr (_SPE)
    BitsPerByte, // Nothing (DataBitsEight) | DataBitsKeyword (_LEN)
    StopBits, // Nothing (StopBitsOne) | StopBitsKeyword (_STB)
    LinesInUse, // ByteConstExpr (_LIN)
    IsBigEndian, // Nothing (LittleEndian) | EndianessKeyword (_END)
    Parity, // Nothing (ParityTypeNone) | ParityTypeKeyword (_PAR)
    FlowControl, // Nothing (FlowControlNone) | FlowControlKeyword (_FLC)
    ReceiveBufferSize, // WordConstExpr (_RXL)
    TransmitBufferSize, // WordConstExpr (_TXL)
```

```

ResourceSource, // StringData
ResourceSourceIndex, // Nothing | ByteConstExpr
ResourceUsage, // Nothing (ResourceConsumer) | ResourceTypeKeyword
DescriptorName, // Nothing | NameString
ShareType, // Nothing (Exclusive) | ShareTypeKeyword (_SHR)
VendorData // Nothing | Object (_VEN)
)

VendorLongTerm :=
VendorLong (
    DescriptorName // Nothing | NameString
) {ByteList}

VendorShortTerm :=
VendorShort (
    DescriptorName // Nothing | NameString
) {ByteList} // Up to 7 bytes

WordBusNumberTerm :=
WordBusNumber (
    ResourceUsage, // Nothing (ResourceConsumer) | ResourceTypeKeyword
    MinType, // Nothing (MinNotFixed) | MinKeyword (_MIF)
    MaxType, // Nothing (MaxNotFixed) | MaxKeyword (_MAF)
    Decode, // Nothing (PosDecode) | DecodeKeyword (_DEC)
    AddressGranularity, // WordConstExpr (_GRA)
    MinAddress, // WordConstExpr (_MIN)
    MaxAddress, // WordConstExpr (_MAX)
    AddressTranslation, // WordConstExpr (_TRA)
    AddressLength, // WordConstExpr (_LEN)
    ResourceSourceIndex, // Nothing | ByteConstExpr
    ResourceSource, // Nothing | StringData
    DescriptorName // Nothing | NameString
)

WordIOTerm :=
WordIO (
    ResourceUsage, // Nothing (ResourceConsumer) | ResourceTypeKeyword
    MinType, // Nothing (MinNotFixed) | MinKeyword (_MIF)
    MaxType, // Nothing (MaxNotFixed) | MaxKeyword (_MAF)
    Decode, // Nothing (PosDecode) | DecodeKeyword (_DEC)
    RangeType, // Nothing (EntireRange) | RangeTypeKeyword (_RNG)
    AddressGranularity, // WordConstExpr (_GRA)
    MinAddress, // WordConstExpr (_MIN)
    MaxAddress, // WordConstExpr (_MAX)
    AddressTranslation, // WordConstExpr (_TRA)
    AddressLength, // WordConstExpr (_LEN)
    ResourceSourceIndex, // Nothing | ByteConstExpr
    ResourceSource, // Nothing | StringData

```

```

DescriptorName, // Nothing | NameString
TranslationType, // Nothing | TypeKeyword (_TTP)
TranslationDensity // Nothing | TranslationKeyword (_TRS)
)

WordSpaceTerm :=
WordSpace (
ResourceType, // ByteConstExpr (_RT), 0xC0 - 0xFF
ResourceUsage, // Nothing (ResourceConsumer) | ResourceTypeKeyword
Decode, // Nothing (PosDecode) | DecodeKeyword (_DEC)
MinType, // Nothing (MinNotFixed) | MinKeyword (_MIF)
MaxType, // Nothing (MaxNotFixed) | MaxKeyword (_MAF)
TypeSpecificFlags, // ByteConstExpr (_TSF)
AddressGranularity, // WordConstExpr (_GRA)
MinAddress, // WordConstExpr (_MIN)
MaxAddress, // WordConstExpr (_MAX)
AddressTranslation, // WordConstExpr (_TRA)
AddressLength, // WordConstExpr (_LEN)
ResourceSourceIndex, // Nothing | ByteConstExpr
ResourceSource, // Nothing | StringData
DescriptorName // Nothing | NameString
)

```

19.3 ASL Concepts

This reference section is for developers who are writing ASL code while developing definition blocks for platforms.

19.3.1 ASL Names

This section describes how to encode object names using ASL.

The following table lists the characters legal in any position in an ASL object name. ASL names are not case-sensitive and will be converted to upper case.

Table 19.2: Named Object Reference Encodings

Value	Description	Title
0x41-0x5A, 0x5F, 0x61-0x7A	Lead character of name ('A'-'Z', '_', 'a'-'z')	LeadNameChar
0x30-0x39, 0x41-0x5A, 0x5F, 0x61-0x7A	Non-lead (trailing) character of name ('A'-'Z', '_', 'a'-'z', '0'-'9')	NameChar

The following table lists the name modifiers that can be prefixed to an ASL name.

Table 19.3: Definition Block Name Modifier Encodings

Value	Description	NamePrefix :=	Follows by...
0x5C	Namespace root ('')	RootPrefix	Name
0x5E	Parent namespace ('^')	ParentPrefix	ParentPrefix or Name

19.3.1.1 `_T_x` Reserved Object Names

The ACPI specification reserves object names with the prefix `_T_` for internal use by the ASL compiler. The ASL compiler may, for example, use these objects to store temporary values when implementing translation of complicated control structures into AML. The ASL compiler must declare `_T_x` objects normally (using `Name`) and must not define them more than once within the same scope.

19.3.2 ASL Literal Constants

This section describes how to encode integer and string constants using ASL.

19.3.2.1 Integers

```
DigitChar      := '0'-'9'
LeadDigitChar  := '1'-'9'
OctalDigitChar := '0'-'7'
HexDigitChar   := DigitChar \| 'A'-'F' \| 'a'-'f'
```

```
Integer        := DecimalConst \| OctalConst \| HexConst
DecimalConst   := LeadDigitChar \| <decimalconst digitchar>
OctalConst     := '0' \| <octalconst octaldigitchar>
HexConst       := <0x hexdigitchar> \| <0x hexdigitchar> \| <HexConst HexDigitChar>
ByteConst      := Integer => 0x00-0xFF
WordConst      := Integer => 0x0000-0xFFFF
DWordConst     := Integer => 0x00000000-0xFFFFFFFF
QWordConst     := Integer => 0x0000000000000000-0xFFFFFFFFFFFFFFFF
```

Numeric constants can be specified in decimal, octal, or hexadecimal. Octal constants are preceded by a leading zero (0), and hexadecimal constants are preceded by a leading zero and either a lower or upper case 'x'. In some cases, the grammar specifies that the number must evaluate to an integer within a limited range, such as 0x00-0xFF, and so on.

19.3.2.2 Strings

```
String         := ''' Utf8CharList '''
Utf8CharList   := Nothing | <escapesequence utf8charlist> | <Utf8Char Utf8CharList>
Utf8Char       := 0x01-0x21 |
                  0x23-0x5B |
                  0x5D-0x7F |
                  0xC2-0xDF 0x80-0xBF |
                  0xE0 0xA0-0xBF 0x80-0xBF |
                  0xE1-0xEC 0x80-0xBF 0x80-0xBF |
                  0xED 0x80-0x9F 0x80-0xBF |
                  0xEE-0xEF 0x80-0xBF 0x80-0xBF |
                  0xF0 0x90-0xBF 0x80-0xBF 0x80-0xBF |
                  0xF1-0xF3 0x80-0xBF 0x80-0xBF 0x80-0xBF |
                  0xF4 0x80-0x8F 0x80-0xBF 0x80-0xBF
EscapeSeq      := SimpleEscapeSeq | OctalEscapeSeq | HexEscapeSeq
SimpleEscapeSeq := \' | \" | \a | \b | \f | \n | \r | \t | \v | \\
OctalEscapeSeq := \ OctalDigitChar |
                  \ OctalDigitChar OctalDigitChar |
                  \ OctalDigitChar OctalDigitChar OctalDigitChar
HexEscapeSeq   := \x HexDigitChar |
```

(continues on next page)

(continued from previous page)

```

                \x HexDigitChar HexDigitChar
NullChar      := 0x00
    
```

String literals consist of zero or more ASCII characters surrounded by double quotation marks (“”). A string literal represents a sequence of characters that, taken together, form a null-terminated string. After all adjacent strings in the constant have been concatenated, a null character is appended.

Strings in the source file may be encoded using the UTF-8 encoding scheme as defined in the Unicode 4.0 specification. UTF-8 is a byte-oriented encoding scheme, where some characters take a single byte and others take multiple bytes. The ASCII character values 0x01-0x7F take up exactly one byte.

However, only one operator currently supports UTF-8 strings: Unicode. Since string literals are defined to contain only non-null character values, both Hex and Octal escape sequence values must be non-null values in the ASCII range 0x01 through 0xFF. For arbitrary byte data (outside the range of ASCII values), the **Buffer** object should be used instead.

Since the backslash is used as the escape character and also the namespace root prefix, any string literals that are to contain a fully qualified namepath from the root of the namespace must use the double backslash to indicate this:

```

Name (_EJD, "\\_SB.PCI0.DOCK1")
    
```

The double backslash is only required within quoted string literals.

Since double quotation marks are used close a string, a special escape sequence (") is used to allow quotation marks within strings. Other escape sequences are listed in the table below.

Table 19.4: ASL Escape Sequences

Escape Sequence	ASCII Character
\a	0x07 (BEL)
\b	0x08 (BS)
\f	0x0C (FF)
\n	0x0A (LF)
\r	0x0D (CR)
\t	0x09 (TAB)
\v	0x0B (VT)
\"	0x22 (“)
\'	0x27 (')
\\	0x5C (\)

Since literal strings are read-only constants, the following ASL statement (for example) is not supported:

```

Store ("ABC", "DEF")
    
```

However, the following sequence of statements is supported:

```

Name (STR, "DEF")
...
Store ("ABC", STR)
    
```

19.3.3 ASL Resource Templates

ASL includes some macros for creating resource descriptors. The ResourceTemplate macro creates a Buffer in which resource descriptor macros can be listed. The ResourceTemplate macro automatically generates an End descriptor and calculates the checksum for the resource template. The format for the ResourceTemplate macro is as follows:

```
ResourceTemplate ()
{
    // List of resource macros
}
```

The following is an example of how these macros can be used to create a resource template that can be returned from a _PRS control method:

```
Name (PRS0, ResourceTemplate ()
{
    StartDependentFn (1, 1)
    {
        IRQ (Level, ActiveLow, Shared) {10, 11}
        DMA (TypeF, NotBusMaster, Transfer16) {4}
        IO (Decode16, 0x1000, 0x2000, 0, 0x100)
        IO (Decode16, 0x5000, 0x6000, 0, 0x100, IO1)
    }
    StartDependentFn (1, 1)
    {
        IRQ (Level, ActiveLow, Shared) {}
        DMA (TypeF, NotBusMaster, Transfer16) {5}
        IO (Decode16, 0x3000, 0x4000, 0, 0x100)
        IO (Decode16, 0x5000, 0x6000, 0, 0x100, IO2)
    }
    EndDependentFn ()
})
```

Occasionally, it is necessary to change a parameter of a descriptor in an existing resource template at run-time (i.e., during a method execution.) To facilitate this, the descriptor macros optionally include a name declaration that can be used later to refer to the descriptor. When a name is declared with a descriptor, the ASL compiler will automatically create field names under the given name to refer to individual fields in the descriptor.

The offset returned by a reference to a resource descriptor field name is either in units of bytes (for 8-, 16-, 32-, and 64-bit field widths) or in bits (for all other field widths). In all cases, the returned offset is the integer offset (in either bytes or bits) of the name from the first byte (offset 0) of the parent resource template.

For example, given the above resource template, the following code changes the minimum and maximum addresses for the I/O descriptor named IO2:

```
CreateWordField (PRS0, IO2._MIN, IMIN)
Store (0xA000, IMIN)

CreateWordField (PRS0, IO2._MAX, IMAX)
Store (0xB000, IMAX)
```

The resource template macros for each of the resource descriptors are listed below, after the table that defines the resource descriptor. The resource template macros are formally defined in *ASL Macros for Resource Descriptors*

The reserved names (such as _MIN and _MAX) for the fields of each resource descriptor are defined in the appropriate table entry of the table that defines that resource descriptor.

19.3.4 ASL Macros

ASL compilers support built-in macros to assist in various ASL coding operations. These macros do not have a corresponding AML opcode, but are instead fully processed by the compiler itself, and may result in the generation of AML opcodes for other ASL/AML operators. The following table lists some of the supported directives and an explanation of their function.

The ASL language provides a wide variety of data types and operators that manipulate data. It also provides mechanisms for both explicit and implicit conversion between the data types when used with ASL operators.

Each of the available ASL macros are described below.

EISAID (TextID)

Converts and compresses the 7-character text argument into its corresponding 4-byte numeric EISA ID encoding (Integer). This can be used when declaring IDs for devices that are EISA IDs.

The algorithm used to convert the TextID is as shown in the following example:

Starting with a seven character input string “PNP0303”, we want to create a DWordConst. This string contains a three character manufacturer code “PNP”, a three character hex product identifier “030”, and a one character revision identifier “3”.

The compressed manufacturer code is created as follows:

- 1) Find hex ASCII value for each letter
- 2) Subtract 40h from each ASCII value
- 3) Retain 5 least significant bits for each letter and discard remaining 0’s:

Byte 0:

Bit 7: reserved (0)

Bit 6-2: 1st character of compressed mfg code “P”

Bit 1-0: Upper 2 bits of 2nd character of mfg code “N”

Byte 1:

Bit 7-5: Lower 3 bits of 2nd character of mfg code “N”

Bit 4-0: 3rd character of mfg code “P”

Byte 2:

Bit 7-4: 1st hex digit of product number “0”

Bit 3-0: 2nd hex digit of product number “3”

Byte 3:

Bit 7-4: 3rd hex digit of product number “0”

Bit 3-0: 4th hex digit of product number “3”

For (Initialize, Predicate, Update) {TermList}

Implements a standard For() loop by converting the For() arguments and TermList into an AML While loop.

Fprintf (Target, FormatString, FormatArgs)

Converts a format string to a series of string Concatenate operations and stores the result to a Named Object (Target).

Printf (FormatString, FormatArgs)

Converts a format string to a series of string Concatenate operations and automatically stores the result to the Debug Object.

ResourceTemplate ()

Used to supply Plug and Play resource descriptor information in human readable form, which is then translated into the appropriate binary Plug and Play resource descriptor encodings in a Resource Template Buffer object. For more information about resource descriptor encodings, (See: *Resource Data Types for ACPI*).

ToPLD (PLDKeywordList)

Converts a PLD (Physical Location of Device) Keyword List into a _PLD Buffer object.

ToUUID (AsciiString)

Converts an ASCII UUID or GUID string to an encoded 128-bit Buffer object.

Unicode (StringData)

Converts a standard ASCII string to a Unicode string returned in a Buffer object.

19.3.5 ASL Data Types

ASL provides a wide variety of data types and operators that manipulate data. It also provides mechanisms for both explicit and implicit conversion between the data types when used with ASL operators.

The table below describes each of the available ASL data types.

Table 19.5: Summary of ASL Data Types

ASL Data Type	Description
[Uninitialized]	No assigned type or value. This is the type of all control method LocalX variables and unused ArgX variables at the beginning of method execution, as well as all uninitialized Package elements. Uninitialized objects must be initialized (via Store or CopyObject) before they may be used as source operands in ASL expressions.
Buffer	An array of bytes. Uninitialized elements are zero by default.
Buffer Field	Portion of a buffer created using CreateBitField, CreateByteField, CreateWordField, CreateQWordField, CreateField, or returned by the Index operator.
Debug Object	Debug output object. Formats an object and prints it to the system debug port. Has no effect if debugging is not active.
Device	Device or bus object
Event	Event synchronization object
Field Unit (within an Operation Region)	Portion of an address space, bit-aligned and of one-bit granularity. Created using Field, BankField, or IndexField.
Integer	An <i>n</i> -bit little-endian unsigned integer. In ACPI 1.0 this was 32 bits. In ACPI 2.0 and later, this is 64 bits. The Integer (DWORD) designation indicates that only the lower 32 bits have meaning and the upper 32 bits of 64-bit integers must be zero (masking of upper bits is not required).
Integer Constant	Created by the ASL terms “Zero”, “One”, “Ones”, and “Revision”.
Method	Control Method (Executable AML function)
Mutex	Mutex synchronization object
Object Reference	Reference to an object created using the RefOf, Index, or CondRefOf operators
Operation Region	Operation Region (A region within an Address Space)
Package	Collection of ASL objects with a fixed number of elements (up to 255).
Power Resource	Power Resource description object

continues on next page

Table 19.5 – continued from previous page

ASL Data Type	Description
Processor	Processor description object
RawDataBuffer	An array of bytes. Uninitialized elements are zero by default. RawDataBuffer does not contain any AML encoding bytes, only the raw bytes.
String	Null-terminated ASCII string.
Thermal Zone	Thermal Zone description object

Note: Compatibility Note: The ability to store and manipulate object references was introduced in ACPI 2.0. In ACPI 1.0 references could not be stored in variables, passed as parameters or returned from functions.

19.3.5.1 Data Type Conversion Overview

ASL provides two mechanisms to convert objects from one data type to another data type at run-time (during execution of the AML interpreter). The first mechanism, Explicit Data Type Conversion, allows the use of explicit ASL operators to convert an object to a different data type. The second mechanism, Implicit Data Type Conversion, is invoked by the AML interpreter when it is necessary to convert a data object to an expected data type before it is used or stored.

The following general rules apply to data type conversions:

- Input parameters are always subject to implicit data type conversion (also known as implicit source operand conversion) whenever the operand type does not match the expected input type.
- Output (target) parameters for all operators except the explicit data conversion operators are subject to implicit data type conversion (also known as implicit result object conversion) whenever the target is an existing named object or named field that is of a different type than the object to be stored.
- Output parameters for the explicit data conversion operators, as well as output parameters that refer to a method local or argument (LocalX or ArgX) are not subject to implicit type conversion.

Both of these mechanisms (explicit and implicit conversion) are described in detail in the sections that follow.

19.3.5.2 Explicit Data Type Conversions

The following ASL operators are provided to explicitly convert an object from one data type to another:

ToBuffer

Convert an Integer, String, or Buffer to an object of type Buffer

ToDecimalString

Convert an Integer, String, or Buffer to an object of type String. The string contains the ASCII representation of the decimal value of the source operand.

ToHexString

Convert an Integer, String, or Buffer to an object of type String. The string contains the ASCII representation of the hexadecimal value of the source operand.

ToInteger

Convert an Integer, String, or Buffer to an object of type Integer.

ToString

Copy directly and convert a Buffer to an object of type String.

The following ASL operator is provided to copy and transfer objects with an explicit result conversion of the type of the target to match the type of the source object:

CopyObject

Explicitly store a copy of the operand object to the target name. No implicit type conversion is performed. (This operator is used to avoid the implicit conversion inherent in the ASL Store operator.)

19.3.5.3 Implicit Data Type Conversions

Automatic or Implicit type conversions can take place at two different times during the execution of an ASL operator. First, it may be necessary to convert one or more of the source operands to the data type(s) expected by the ASL operator. Second, the result of the operation may require conversion before it is stored into the destination. (Many of the ASL operators can store their result optionally into an object specified by the last parameter. In these operators, if the destination is specified, the action is exactly as if a Store operator had been used to place the result in the destination.)

Such data conversions are performed by an AML interpreter during execution of AML code and are known collectively as Implicit Operand Conversions. As described briefly above, there are two different types of implicit operand conversion:

1. Conversion of a source operand from a mismatched data type to the correct data type required by an ASL operator, called Implicit Source Conversion. This conversion occurs when a source operand must be converted to the operand type expected by the operator. Any or all of the source operands may be converted in this manner before the execution of the ASL operator can proceed.
2. Conversion of the result of an operation to the existing type of a target operand before it is stored into the target operand, called Implicit Result Conversion. This conversion occurs when the target is a fixed type such as a named object or a field. When storing to a method Local or Arg, no conversion is performed or required because these data types are of variable type (the store simply overwrites any existing object and the existing type).

The following ASL operator is provided to copy and transfer objects with an implicit result conversion to the existing type of the target object:

Store

Store a copy of the operand object to the target name. Implicit result conversion is performed if the target name is of a fixed data type (see above). However, Stores to method locals and arguments do not perform implicit conversion and are therefore the same as using CopyObject.

19.3.5.4 Implicit Source Operand Conversion

During the execution of an ASL operator, each source operand is processed by the AML interpreter as follows:

- If the operand is of the type expected by the operator, no conversion is necessary.
- If the operand type is incorrect, attempt to convert it to the proper type.
- For the Concatenate operator and logical operators (LEqual, LGreater, LGreaterEqual, LLess, LLessEqual, and LNotEqual), the data type of the first operand dictates the required type of the second operand, and for Concatenate only, the type of the result object. (The second operand is implicitly converted, if necessary, to match the type of the first operand.)
- If conversion is impossible, abort the running control method and issue a fatal error.

An implicit source conversion will be attempted anytime a source operand contains a data type that is different than the type expected by the operator. For example:

```
Store ("5678", Local1)
Add (0x1234, Local1, BUF1)
```

In the Add statement above, Local1 contains a String object and must undergo conversion to an Integer object before the Add operation can proceed.

In some cases, the operator may take more than one type of operand (such as Integer and String). In this case, depending on the type of the operand, the highest priority conversion is applied. The table below describes the source operand conversions available. For example:

```
Store (Buffer (1) {}, Local0)
Name (ABCD, Buffer (10) {1, 2, 3, 4, 5, 6, 7, 8, 9, 0})
CreateDWordField (ABCD, 2, XYZ)
Name (MNOP, "1234")
Concatenate (XYZ, MNOP, Local0)
```

The Concatenate operator can take an Integer, Buffer or String for its first two parameters and the type of the first parameter determines how the second parameter will be converted. In this example, the first parameter is of type Buffer Field (from the CreateDWordField operator). What should it be converted to: Integer, Buffer or String? According to the table *Object Conversion Rules* the highest priority conversion is to Integer. Therefore, both of the following objects will be converted to Integers:

```
XYZ (0x05040302)
MNOP (0x31, 0x32, 0x33, 0x34)
```

And will then be joined together and the resulting type and value will be:

```
Buffer (0x02, 0x03, 0x04, 0x05, 0x31, 0x32, 0x33, 0x34)
```

19.3.5.5 Implicit Result Object Conversion

For all ASL operators that generate and store a result value (including the Store operator), the result object is processed and stored by the AML interpreter as follows:

- If the ASL operator is one of the explicit conversion operators (ToString, ToInteger, etc., and the CopyObject operator), no conversion is performed. (In other words, the result object is stored directly to the target and completely overwrites any existing object already stored at the target.)
- If the target is a method local or argument (LocalX or ArgX), no conversion is performed and the result is stored directly to the target.
- If the target is a fixed type such as a named object or field object, an attempt is made to convert the source to the existing target type before storing.
- If conversion is impossible, abort the running control method and issue a fatal error.

An implicit result conversion can occur anytime the result of an operator is stored into an object that is of a fixed type. For example:

```
Name (BUF1, Buffer (10))
Add (0x1234, 0x789A, BUF1)
```

Since BUF1 is a named object of fixed type *Buffer*, the Integer result of the Add operation must be converted to a Buffer before it is stored into BUF1.

19.3.5.6 Data Types and Type Conversions

The following table lists the available ASL data types and the available data type conversions (if any) for each. The entry for each data type is fully cross-referenced, showing both the types to which the object may be converted as well as all other types that may be converted to the data type.

The allowable conversions apply to both explicit and implicit conversions.

Table 19.6: Data Types and Type Conversions

ASL Data Type	Can be implicitly or explicitly converted to these Data Types (In priority order)	Can be implicitly or explicitly converted from these Data Types
[Uninitialized]	None. Causes a fatal error when used as a source operand in any ASL statement.	Integer, String, Buffer, Package, Object Reference
Buffer	Integer, String, Debug Object	Integer, String
Buffer Field	Integer, Buffer, String, Debug Object	Integer, Buffer, String
Debug Object	None. Causes a fatal error when used as a source operand in any ASL statement.	Integer, String, Buffer, Package, Field Unit, Buffer Field
Device	None	None
Event	None	None
Field Unit (within an Operation Region)	Integer, Buffer, String, Debug Object	Integer, Buffer, String
Integer	Buffer, Buffer Field, Field Unit, String, Debug Object	Buffer, String
Integer Constant	Integer, Debug Object	None. Also, storing any object to a constant is a no-op, not an error.
Method	None	None
Mutex	None	None
Object Reference	None	None
Operation Region	None	None
Package	Debug Object	None
String	Integer, Buffer, Debug Object	Integer, Buffer
Power Resource	None	None
RawDataBuffer	None	None
Thermal Zone	None	None

19.3.5.7 Data Type Conversion Rules

The following table presents the detailed data conversion rules for each of the allowable data type conversions. These conversion rules are implemented by the AML Interpreter and apply to all conversion types – explicit conversions, implicit source conversions, and implicit result conversions.

Table 19.7: Object Conversion Rules

To convert from an object of this Data Type	To an object of this Data Type	This action is performed by the AML Interpreter
Buffer	Buffer Field	The contents of the buffer are copied to the Buffer Field. If the buffer is smaller than the size of the buffer field, it is zero extended. If the buffer is larger than the size of the buffer field, the upper bits are truncated. Compatibility Note: This conversion was first introduced in ACPI 2.0. The behavior in ACPI 1.0 was undefined.
Buffer	Debug Object	Each buffer byte is displayed as a hexadecimal integer, delimited by spaces and/or commas.
Buffer	Field Unit	The entire contents of the buffer are copied to the Field Unit. If the buffer is larger (in bits) than the size of the Field Unit, it is broken into pieces and completely written to the Field Unit, lower chunks first. If the buffer (or the last piece of the buffer, if broken up) is smaller than the size of the Field Unit, it is zero extended before being written.
Buffer	Integer	If no integer object exists, a new integer is created. The contents of the buffer are copied to the Integer, starting with the least-significant bit and continuing until the buffer has been completely copied — up to the maximum number of bits in an Integer. The size of an Integer is indicated by the Definition Block table header’s Revision field. A Revision field value less than 2 indicates that the size of an Integer is 32 bits. A value greater than or equal to 2 signifies that the size of an Integer is 64 bits. If the buffer is smaller than the size of an integer, it is zero extended. If the buffer is larger than the size of an integer, it is truncated. Conversion of a zero-length buffer to an integer is not allowed.
Buffer	String	If no string object exists, a new string is created. If the string already exists, it is completely overwritten and truncated or extended to accommodate the converted buffer exactly. The entire contents of the buffer are converted to a string of two-character hexadecimal numbers, each separated by a space. A zero-length buffer will be converted to a null (zero-length) string.
Buffer Field	[See the Integer and Buffer Rules]	If the Buffer Field is smaller than or equal to the size of an Integer (in bits), it will be treated as an Integer. Otherwise, it will be treated as a buffer. The size of an Integer is indicated by the Definition Block table header’s Revision field. A Revision field value less than 2 indicates that the size of an Integer is 32 bits. A value greater than or equal to 2 signifies that the size of an Integer is 64 bits. (See the conversion rules for the Integer and Buffer data types.)
Field Unit	[See the Integer and Buffer Rules]	If the Field Unit is smaller than or equal to the size of an Integer (in bits), it will be treated as an Integer. If the Field Unit is larger than the size of an Integer, it will be treated as a Buffer. The size of an Integer is indicated by the Definition Block table header’s Revision field. A Revision field value less than 2 indicates that the size of an Integer is 32 bits. A value greater than or equal to 2 signifies that the size of an Integer is 64 bits. (See the conversion rules for the Integer and Buffer data types.)

continues on next page

Table 19.7 – continued from previous page

To convert from an object of this Data Type	To an object of this Data Type	This action is performed by the AML Interpreter
Integer	Buffer	If no buffer object exists, a new buffer object is created based on the size of the integer (4 bytes for 32-bit integers and 8 bytes for 64-bit integers). If a buffer object already exists, the Integer overwrites the entire Buffer object. If the integer requires more bits than the size of the Buffer, then the integer is truncated before being copied to the Buffer. If the integer contains fewer bits than the size of the buffer, the Integer is zero-extended to fill the entire buffer.
Integer	Buffer Field	The Integer overwrites the entire Buffer Field. If the integer is smaller than the size of the buffer field, it is zero-extended. If the integer is larger than the size of the buffer field, the upper bits are truncated. Compatibility Note: This conversion was first introduced in ACPI 2.0. The behavior in ACPI 1.0 was undefined.
Integer	Debug Object	The integer is displayed as a hexadecimal value.
Integer	Field Unit	The Integer overwrites the entire Field Unit. If the integer is smaller than the size of the buffer field, it is zero-extended. If the integer is larger than the size of the buffer field, the upper bits are truncated.
Integer	String	If no string object exists, a new string object is created based on the size of the integer (8 characters for 32-bit integers and 16 characters for 64-bit integers). If the string already exists, it is completely overwritten and truncated or extended to accommodate the converted integer exactly. In either case, the entire integer is converted to a string of hexadecimal ASCII characters.
Package	Package	If no package object exists, a new package object is created. If the package already exists, it is completely overwritten and truncated or extended to accommodate the source package exactly. Any and all existing valid (non-null) package elements of the target package are deleted, and the entire contents of the source package are copied into the target package.
Package	Debug Object	Each element of the package is displayed based on its type.
String	Buffer	If no buffer object exists, a new buffer object is created. If a buffer object already exists, it is completely overwritten. If the string is longer than the buffer, the string is truncated before copying. If the string is shorter than the buffer, the remaining buffer bytes are set to zero. In either case, the string is treated as a buffer, with each ASCII string character copied to one buffer byte, including the null terminator. A null (zero-length) string will be converted to a zero-length buffer.
String	Buffer Field	The string is treated as a buffer. If this buffer is smaller than the size of the buffer field, it is zero extended. If the buffer is larger than the size of the buffer field, the upper bits are truncated. Compatibility Note: This conversion was first introduced in ACPI 2.0. The behavior in ACPI 1.0 was undefined.
String	Debug Object	Each string character is displayed as an ASCII character.
String	Field Unit	Each character of the string is written, starting with the first, to the Field Unit. If the Field Unit is less than eight bits, then the upper bits of each character are lost. If the Field Unit is greater than eight bits, then the additional bits are zeroed.

continues on next page

Table 19.7 – continued from previous page

To convert from an object of this Data Type	To an object of this Data Type	This action is performed by the AML Interpreter
String	Integer	If no integer object exists, a new integer is created. The integer is initialized to the value zero and the ASCII string is interpreted as a hexadecimal constant. Each string character is interpreted as a hexadecimal value ('0'-'9', 'A'-'F', 'a'-'f'), starting with the first character as the most significant digit, and ending with the first non-hexadecimal character, end-of-string, or when the size of an integer is reached (8 characters for 32-bit integers and 16 characters for 64-bit integers). Note: the first non-hex character terminates the conversion without error, and a "0x" prefix is not allowed. Conversion of a null (zero-length) string to an integer is not allowed.

19.3.5.8 Rules for Storing and Copying Objects

The table below lists the actions performed when storing objects to different types of named targets. ASL provides the following types of “store” operations:

- The Store operator is used to explicitly store an object to a location, with implicit conversion support of the source object.
- Many of the ASL operators can store their result optionally into an object specified by the last parameter. In these operators, if the destination is specified, the action is exactly as if a Store operator had been used to place the result in the destination.
- The CopyObject operator is used to explicitly store a copy of an object to a location, with no implicit conversion support.

Table 19.8: Object Storing and Copying Rules

When Storing an object of any datatype to this type of Target location	This action is performed by the Store operator or any ASL operator with a Target operand	This action is performed by the CopyObject operator
Method ArgX variable	The object is copied to the destination with no conversion applied, with one exception. If the ArgX contains an Object Reference, an automatic de-reference occurs and the object is copied to the target of the Object Reference instead of overwriting the contents of ArgX.	The object is copied to the destination with no conversion applied, with one exception. If the ArgX contains an Object Reference, an automatic de-reference occurs and the object is copied to the target of the Object Reference instead of overwriting the contents of ArgX.
Method LocalXvariable	The object is copied to the destination with no conversion applied. Even if LocalX contains an Object Reference, it is overwritten.	The object is copied to the destination with no conversion applied. Even if LocalX contains an Object Reference, it is overwritten.
Field Unit or BufferField	The object is copied to the destination after implicit result conversion is applied.	Fields permanently retain their type and cannot be changed. Therefore, CopyObject can only be used to copy an object of type Integer or Buffer to fields.

continues on next page

Table 19.8 – continued from previous page

When Storing an object of any datatype to this type of Target location	This action is performed by the Store operator or any ASL operator with a Target operand	This action is performed by the CopyObject operator
Named data object	The object is copied to the destination after implicit result conversion is applied to match the existing type of the named location.	The object and type are copied to the named location.

19.3.5.8.1 ArgX Objects

1. Read from ArgX parameters

- **ObjectReference** - Automatic dereference, return the target of the reference. Use of DeRefOf returns the same.
- **Buffer** - Return the Buffer. Can create an Index, Field, or Reference to the buffer.
- **Package** - Return the Package. Can create an Index or Reference to the package.
- **All other object types** - Return the object.

Example method invocation for the table below:

```
MTHD (RefOf (Obj), Buf, Pkg, Obj)
```

Table 19.9: Reading from ArgX Objects

Parameter	MTHD ArgX Type	Read operation on ArgX	Result of read
RefOf (Obj),	Reference to object Obj	Store (Arg0, ...)	Obj
"	"	CopyObject (Arg0, ...)	Obj
"	"	DeRefOf (Arg0)	Obj
Buf,	Buffer	Store (Arg1, ...)	Buf
"	"	CopyObject (Arg1, ...)	Buf
"	"	Index (Arg1, ...)	Index (Buf)
"	"	Field (Arg1, ...)	Field (Buf)
Pkg	Package	Store (Arg2, ...)	Pkg
"	"	CopyObject (Arg2, ...)	Pkg
"	"	Index (Arg2, ...)	Index (Pkg)
Obj	All other object types	Store (Arg3, ...)	Obj
"	"	CopyObject (Arg3, ...)	Obj

2. Store to ArgX parameters

- **ObjectReference objects** - Automatic dereference, copy the object and overwrite the final target.
- **All other object types** - Copy the object and overwrite the ArgX variable. (Direct writes to buffer or package ArgX parameters will also simply overwrite ArgX)

Table 19.10: Writing to ArgX Objects

Current type of ArgX	Object to be written	Write operation on ArgX	Result of write (in ArgX)
RefOf (OldObj)	Obj (any type)	Store (... , ArgX)	RefOf (copy of Obj)
"	"	CopyObject (... , ArgX)	RefOf (copy of Obj)
All other object types	Obj (Any type)	Store (... , ArgX)	Copy of Obj
"	"	CopyObject (... , ArgX)	Copy of Obj

Note: RefOf (ArgX) returns a reference to ArgX.

19.3.5.8.2 LocalX Objects

1. Read from LocalX variables

- **ObjectReference** - If performing a DeRefOf return the target of the reference. Otherwise, return the reference.
- **All other object types** - Return a the object

Table 19.11: Reading from LocalX Objects

Current LocalX Type	Read operation on LocalX	Result of read
RefOf (Obj)	Store (LocalX, ...)	RefOf (Obj)
"	CopyObject (LocalX, ...)	RefOf (Obj)
"	DeRefOf (LocalX)	Obj
Obj (All other types)	Store (LocalX, ...)	Obj
"	CopyObject (LocalX, ...)	Obj

2. Store to LocalX variables

- **All object types** - Delete any existing object in LocalX first, then store a copy of the object.

Table 19.12: Writing to LocalX Objects

Current LocalX-Type	Object to be written	Write operation on LocalX	Result of write (in LocalX)
All object types	Obj (any type)	Store (... , LocalX)	Copy of Obj
"	"	CopyObject (... , LocalX)	Copy of Obj

19.3.5.8.3 Named Objects

1. Read from Named object

- **ObjectReference** - If performing a DeRefOf return the target of the reference. Otherwise, return the reference.
- **All other object types** - Return the object

Table 19.13: Reading from Named Objects

Current NAME Type	Read operation on NAME	Result of read
RefOf (Obj)	Store (NAME, ...)	RefOf (Obj)
"	CopyObject (NAME, ...)	RefOf (Obj)
"	DeRefOf (NAME)	Obj
Obj (All other types)	Store (NAME, ...)	Obj
"	CopyObject (NAME, ...)	Obj

2. Store to Named object

- **All object types** - Delete any existing object in NAME first, then store a copy of the object. The Store operator will perform an implicit conversion to the existing type in NAME. CopyObject does not perform an implicit store.

Table 19.14: Writing to Named Objects

Current Type	NAME	Object to be written	Write operation on NAME	Result of write (in NAME)
Any (Any Type)		Obj (Any type)	Store (... , NAME)	Copy of Obj (converted to match existing type of NAME)
"		"	CopyObject (... , NAME)	Copy of Obj (No conversion)

19.4 ASL Operators Summary

Table 19.15: ASL Operators Summary List

Operator Name	Description
AccessAs	Change Field Access
Acquire	Acquire a mutex
Add	Integer Add
Alias	Define a name alias
And	Integer Bitwise And
ArgX	Method argument data objects
BankField	Declare fields in a banked configuration object
Break	Continue following the innermost enclosing While
BreakPoint	Used for debugging, stops execution in the debugger
Buffer	Declare Buffer object
Case	Expression for conditional execution
Concatenate	Concatenate two strings, integers or buffers
ConcatenateResTemplate	Concatenate two resource templates
CondRefOf	Conditional reference to an object
Connection	Declare Field Connection Attributes
Continue	Continue innermost enclosing While loop
CopyObject	Copy and existing object
CreateBitField	Declare a bit field object of a buffer object
CreateByteField	Declare a byte field object of a buffer object
CreateDWordField	Declare a DWord field object of a buffer object
CreateField	Declare an arbitrary length bit field of a buffer object
CreateQWordField	Declare a QWord field object of a buffer object
CreateWordField	Declare a Word field object of a buffer object
DataTableRegion	Declare a Data Table Region
Debug	Debugger output
Decrement	Decrement an Integer
Default	Default execution path in Switch()
DefinitionBlock	Declare a Definition Block
DerefOf	Dereference an object reference
Device	Declare a bus/device object
Divide	Integer Divide
DMA	DMA Resource Descriptor macro
DWordIO	DWord IO Resource Descriptor macro
DWordMemory	DWord Memory Resource Descriptor macro
DWordSpace	DWord Space Resource Descriptor macro
EisaId	EISA ID String to Integer conversion macro
Else	Alternate conditional execution
ElseIf	Conditional execution

continues on next page

Table 19.15 – continued from previous page

Operator Name	Description
EndDependentFn	End Dependent Function
Event	Resource Descriptor macro
ExtendedIO	Declare an event synchronization object
ExtendedMemory	Extended IO Resource Descriptor macro
ExtendedSpace	Extended Space Resource Descriptor macro
External	Declare external objects
Fatal	Fatal error check
Field	Declare fields of an operation region object
FindSetLeftBit	Index of first least significant bit set
FindSetRightBit	Index of first most significant bit set
FixedDMA	Fixed DMA Resource Descriptor macro
FixedIO	Fixed I/O Resource Descriptor macro
Fprintf	Stores formatted string to a Named Object
FromBCD	Convert from BCD to numeric
Function	Declare control method
GpioInt	GPIO Interrupt Connection Resource Descriptor macro
GpioIo	GPIO IO Connection Resource Descriptor macro
I2CSerialBusV2	I2C Serialbus Connection Resource Descriptor (Version 2) macro
If	Conditional execution
Include	Include another ASL file
Increment	Increment a Integer
Index	Indexed Reference to member object
IndexField	Declare Index/Data Fields
Interrupt	Interrupt Resource Descriptor macro
IO	IO Resource Descriptor macro
IRQ	Interrupt Resource Descriptor macro
IRQNoFlags	Short Interrupt Resource Descriptor macro
LAnd	Logical And
LEqual	Logical Equal
LGreater	Logical Greater
LGreaterEqual	Logical Not less
LLess	Logical Less
LLessEqual	Logical Not greater
LNot	Logical Not
LNotEqual	Logical Not equal
Load	Load differentiating definition block
LoadTable	Load Table from RSDT/XSDT
LocalX	Method local data objects
LOr	Logical Or
Match	Search for match in package array
Memory24	Memory Resource Descriptor macro
Memory32	Memory Resource Descriptor macro
Memory32Fixed	Memory Resource Descriptor macro
Method	Declare a control method
Mid	Return a portion of buffer or string
Mod	Integer Modulo
Multiply	Integer Multiply
Mutex	Declare a mutex synchronization object
Name	Declare a Named object

continues on next page

Table 19.15 – continued from previous page

Operator Name	Description
NAnd	Integer Bitwise Nand
NoOp	No operation
NOr	Integer Bitwise Nor
Not	Integer Bitwise Not
Notify	Notify Object of event
ObjectType	Type of object
Offset	Set Field Offset within operation range
One	Constant One Object (1)
Ones	Constant Ones Object (-1)
OperationRegion	Declare an operational region
Or	Integer Bitwise Or
Package	Declare a package object
PowerResource	Declare a power resource object
Printf	Stores formatted string to Debug Object
Processor	Declare a processor package
QWordIO	QWord IO Resource Descriptor macro
QWordMemory	QWord Memory Resource Descriptor macro
QWordSpace	Qword Space Resource Descriptor macro
RawDataBuffer	Declare a RawDataBuffer
RefOf	Create Reference to an object
Register	Generic register Resource Descriptor macro
Release	Release a synchronization object
Reset	Reset a synchronization object
ResourceTemplate	Resource to buffer conversion macro
Return	Return from method execution
Revision	Constant revision object
Scope	Open named scope
ShiftLeft	Integer shift value left
ShiftRight	Integer shift value right
Signal	Signal a synchronization object
SizeOf	Get the size of a buffer, string, or package
Sleep	Sleep n milliseconds (yields the processor)
SPISerialbusV2	SPI Serialbus Connection Resource Descriptor (Version 2) macro
Stall	Delay n microseconds (does not yield the processor)
StartDependentFn	Start Dependent Function Resource Descriptor macro
StartDependentFnNoPri	Start Dependent Function Resource Descriptor macro
Store	Store object Integer
Subtract	Subtract
Switch	Select code to execute based on expression value
ThermalZone	Declare a thermal zone package.
Timer	Get 64-bit timer value
ToBCD	Convert Integer to BCD
ToBuffer	Convert data type to buffer
ToDecimalString	Convert data type to decimal string
ToHexString	Convert data type to hexadecimal string
ToInteger	Convert data type to integer
ToPLD	Converts a PLD Keyword List into a _PLD buffer
ToString	Copy ASCII string from buffer
ToUUID	Convert ASCII string to UUID

continues on next page

Table 19.15 – continued from previous page

Operator Name	Description
Unicode	String to Unicode conversion macro
UARTSerialBusV2	UART SerialBus Connection Resource Descriptor (version2) macro
VendorLong	Vendor Resource Descriptor
VendorShort	Vendor Resource Descriptor
Wait	Wait on an Event
While	Conditional loop
WordBusNumber	Word Bus number Resource Descriptor macro
WordIO	Word IO Resource Descriptor macro
WordSpace	Word Space Resource Descriptor macro
Xor	Integer Bitwise Xor
Zero	Constant Zero object 0

19.5 ASL Operator Summary by Type

Table 19.16: ASL compiler controls

<i>Operator Name</i>	<i>Description</i>
External	Declare external objects
Include	Include another ASL file

Table 19.17: ACPI table management

<i>Operator Name</i>	<i>Description</i>
DefinitionBlock	Load definition block
Declare a Definition Block	LoadTable
Load	Load Table from RSDT/XSDT

Table 19.18: Miscellaneous named object creation

<i>Operator Name</i>	<i>Description</i>
Alias	Define a name alias
Buffer	Declare Buffer object
Device	Declare a bus/device object
Function	Declare a control method
Method	Declare a control method
Name	Declare a Named object
Package	Declare a package object
PowerResource	Declare a power resource object
Processor	Declare a processor package
RawDataBuffer	Declare a RawDataBuffer
Scope	Open named scope
ThermalZone	Declare a thermal zone package

Table 19.19: Operation Regions and Fields

<i>Operator Name</i>	<i>Description</i>
AccessAs	Change Field Access

continues on next page

Table 19.19 – continued from previous page

<i>Operator Name</i>	<i>Description</i>
BankField	Declare fields in a banked configuration object
Connection	Declare Field Connection Attributes
DataTableRegion	Declare a Data Table Region
Field	Declare fields of an operation region object
IndexField	Declare Index/Data Fields
Offset	Set Field offset within operation region
OperationRegion	Declare an operational region

Table 19.20: **Buffer Fields**

<i>Operator Name</i>	<i>Description</i>
CreateBitField	Declare a bit field object of a buffer object
CreateByteField	Declare a byte field object of a buffer object
CreateDWordField	Declare a DWord field object of a buffer object
CreateField	Declare an arbitrary length bit field of a buffer object
CreateQWordField	Declare a QWord field object of a buffer object
CreateWordField	Declare a Word field object of a buffer object

Table 19.21: **Synchronization**

<i>Operator Name</i>	<i>Description</i>
Acquire	Acquire a mutex
Event	Declare an event synchronization object
Mutex	Declare a mutex synchronization object
Notify	Notify Object of event
Release	Release a synchronization object
Reset	Reset a synchronization object
Signal	Signal a synchronization object
Wait	Wait on an Event

Table 19.22: **Object references**

<i>Operator Name</i>	<i>Description</i>
CondRefOf	Conditional reference to an object
DerefOf	Dereference an object reference
RefOf	Create Reference to an object

Table 19.23: **Integer arithmetic**

<i>Operator Name</i>	<i>Description</i>
Add	Integer Add
And	Integer Bitwise And
Decrement	Decrement an Integer
Divide	Integer Divide
FindSetLeftBit	Index of first least significant bit set
FindSetRightBit	Index of first most significant bit set
Increment	Increment a Integer
Mod	Integer Modulo
Multiply	Integer Multiply

continues on next page

Table 19.23 – continued from previous page

<i>Operator Name</i>	<i>Description</i>
NAnd	Integer Bitwise Nand
NOr	Integer Bitwise Nor
Not	Integer Bitwise Not
Or	Integer Bitwise Or
ShiftLeft	Integer shift value left
ShiftRight	Integer shift value right I
Subtract	Integer Subtract
Xor	Integer Bitwise Xor

Table 19.24: **Logical operators**

<i>Operator Name</i>	<i>Description</i>
LAnd	Logical And
LEqual	Logical Equal
LGreater	Logical Greater
LGreaterEqual	Logical Not less
LLess	Logical Less
LLessEqual	Logical Not greater
LNot	Logical Not
LNotEqual	Logical Not equal
LOr	Logical Or

Table 19.25: **Method execution control**

<i>Operator Name</i>	<i>Description</i>
Break	Continue following the innermost enclosing While
BreakPoint	Used for debugging, stops execution in the debugger
Case	Expression for conditional execution
Continue	Continue innermost enclosing While loop
Default	Default execution path in Switch()
Else	Alternate conditional execution
ElseIf	Conditional execution
Fatal	Fatal error check
If	Conditional execution
NoOp	No operation
Return	Return from method execution
Sleep	Sleep in milliseconds (yields the processor)
Stall	Delay in microseconds (does not yield the processor)
Switch	Select code to execute based on expression value
While	Conditional loop

Table 19.26: **Data type conversion and manipulation**

<i>Operator Name</i>	<i>Description</i>
Concatenate	Concatenate two strings, integers or buffers
CopyObject	Copy and existing object
Debug	Debugger output
Eisald	EISA ID String to Integer conversion macro
Fprintf	Stores formatted string to a Named Object

continues on next page

Table 19.26 – continued from previous page

<i>Operator Name</i>	<i>Description</i>
FromBCD	Convert from BCD to numeric
Index	Indexed Reference to member object
Match	Search for match in package array
Mid	Return a portion of buffer or string
ObjectType	Type of object
Printf	Stores formatted string to Debug Object
SizeOf	Get the size of a buffer, string, or package
Store	Store object
Timer	Get 64-bit timer value
ToBCD	Convert Integer to BCD
ToBuffer	Convert data type to buffer
ToDecimalString	Convert data type to decimal string
ToHexString	Convert data type to hexadecimal string
ToInteger	Convert data type to integer
ToPLD	Converts a PLD Keyword List into a _PLD buffer
ToString	Copy ASCII string from buffer
ToUUID	Convert ASCII string to UUID
Unicode	String to Unicode conversion macro

Table 19.27: **Resource Descriptor macros**

<i>Operator Name</i>	<i>Description</i>
ConcatenateResTemplate	Concatenate two resource templates
DMA	DMA Resource Descriptor macro
DWordIO	DWord IO Resource Descriptor macro
DWordMemory	DWord Memory Resource Descriptor macro
DWordSpace	DWord Space Resource Descriptor macro
EndDependentFn	End Dependent Function Resource Descriptor macro
ExtendedIO	Extended I/O Resource Descriptor macro
ExtendedMemory	Extended Memory Resource Descriptor macro
ExtendedSpace	Extended Space Resource Descriptor macro
FixedDMA	Fixed DMA resource Descriptor macro
FixedIO	Fixed I/O Resource Descriptor macro
GpioInt	GPIO Interrupt Connection Resource Descriptor macro
GpioIO	GPIO IO Connection Resource Descriptor macro
I2CSerialBusV2	I2C SerialBus Connection Resource Descriptor (Version 2) macro
Interrupt	Interrupt Resource Descriptor macro
IO	IO Resource Descriptor macro
IRQ	Interrupt Resource Descriptor macro
IRQNoFlags	Short Interrupt Resource Descriptor macro
Memory24	Memory Resource Descriptor macro
Memory32	Memory Resource Descriptor macro
Memory32Fixed	Memory Resource Descriptor macro
QWordIO	QWord IO Resource Descriptor macro
QWordMemory	QWord Memory Resource Descriptor macro
QWordSpace	Qword Space Resource Descriptor macro
Register	Generic register Resource Descriptor macro
ResourceTemplate	Resource to buffer conversion macro
SPISerialBusV2	SPI SerialBus Connection Resource Descriptor (Version 2) macro

continues on next page

Table 19.27 – continued from previous page

<i>Operator Name</i>	<i>Description</i>
StartDependentFn Start-DependentFnNoPri	Start Dependent Function Resource Descriptor macro
UARTSerialBusV2	UART SerialBus Connection Resource Descriptor (Version 2) macro
VendorLong	Vendor Resource Descriptor
VendorShort	Vendor Resource Descriptor
WordBusNumber	Word Bus number Resource Descriptor macro
WordIO	Word IO Resource Descriptor macro
WordSpace	Word Space Resource Descriptor macro

Table 19.28: Constants

<i>Operator Name</i>	<i>Description</i>
One	Constant One Object (1)
Ones	Constant Ones Object (-1)
Revision	Constant revision object
Zero	Constant Zero object (0)

Table 19.29: Control method objects

<i>Operator Name</i>	<i>Description</i>
ArgX	Method argument data objects
LocalX	Method local data objects

19.6 ASL Operator Reference

This section describes each of the ASL operators. The syntax for each operator is given, with a description of each argument and an overall description of the operator behavior. Example ASL code is provided for the more complex operators.

ASL operators can be categorized as follows:

- Named Object creation
- Method execution control (If, Else, While, etc.)
- Integer math
- Logical operators
- Resource Descriptor macros
- Object conversion
- Utility/Miscellaneous

19.6.1 AccessAs (Change Field Unit Access)

Syntax:

```
AccessAs (AccessType, AccessAttribute)
AccessAs (AccessType, AccessAttribute (AccessLength))
```

Arguments

AccessType is an *AccessTypeKeyword* that specifies the type of access desired (**ByteAcc**, **WordAcc**, etc.). *AccessAttribute* is an optional argument of type *AccessAttributeKeyword* that specifies additional protocols to be used, such as **AttribQuick**, **AttribSendReceive**, etc. *AccessLength* is a required argument for some of the Access Attributes.

Description

The **AccessAs** operator is used within a *FieldList* to specify the Access Type, Access Attributes, and Access Length for the remaining *FieldUnits* within the list (or until another **AccessAs** operator is encountered.) It allows FieldUnits to have different access types within a single Field definition.

Supported *AccessTypes*:

- AnyAcc
- ByteAcc
- WordAcc
- DwordAcc
- QWordAcc
- BufferAcc

Supported simple *AccessAttributes* (with SMBus synonyms):

- AttribQuick (*SMBQuick*)
- AttribSendReceive (*SMBSendReceive*)
- AttribByte (*SMBByte*)
- AttribWord (*SMBWord*)
- AttribBlock (*SMBBlock*)
- AttribProcessCall (*SMBProcessCall*)
- AttribBlockProcessCall (*SMBBlockProcessCall*)

Access Attributes that require an *AccessLength* argument:

- AttribBytes (*AccessLength*)
- AttribRawBytes (*AccessLength*)
- AttribRawProcessBytes (*AccessLength*)

19.6.2 Acquire (Acquire a Mutex)

Syntax:

```
Acquire (SyncObject, TimeoutValue) => Boolean
```

Arguments

SyncObject must be a mutex synchronization object. *TimeoutValue* is evaluated as an Integer.

Description

Ownership of the Mutex is obtained. If the Mutex is already owned by a different invocation, the current execution thread is suspended until the owner of the Mutex releases it or until at least *TimeoutValue* milliseconds have elapsed. A Mutex can be acquired more than once by the same invocation.

Note: For Mutex objects referenced by a *_DLM* object, the host OS may also contend for ownership.

This operation returns **True** if a timeout occurred and the mutex ownership was not acquired. A *TimeoutValue* of 0xFFFF (or greater) indicates that there is no timeout and the operation will wait indefinitely.

19.6.3 Add (Integer Add)

Syntax:

```
Add (Addend1, Addend2, Result) => Integer
Result = Addend1 + Addend2 => Integer
Result += Addend => Integer
```

Arguments

Addend1 and *Addend2* are evaluated as Integers.

Description

The operands are added and the result is optionally stored into *Result*. Overflow conditions are ignored and the result of overflows simply loses the most significant bits.

19.6.4 Alias (Declare Name Alias)

Syntax:

```
Alias (SourceObject, AliasObject)
```

Arguments

SourceObject is any named object. *AliasObject* is a NameString.

Description

Creates a new object named *AliasObject* that refers to and acts exactly the same as *SourceObject*.

AliasObject is created as an alias of *SourceObject* in the namespace. The *SourceObject* name must already exist in the namespace. If the alias is to a name within the same definition block, the *SourceObject* name must be logically ahead of this definition in the block.

Example:

The following example shows the use of an **Alias** term:

```
Alias (\SUS.SET.EVEN, SSE)
```

19.6.5 And (Integer Bitwise And)

Syntax:

```
And (Source1, Source2, Result) => Integer
Result = Source1 & Source2 => Integer
Result &= Source => Integer
```

Arguments

Source1 and *Source2* are evaluated as Integers.

Description

A bitwise AND is performed and the result is optionally stored into *Result*.

19.6.6 Argx (Method Argument Data Objects)

Syntax:

```
Arg0 | Arg1 | Arg2 | Arg3 | Arg4 | Arg5 | Arg6
```

Description

Up to 7 argument-object references can be passed to a control method. On entry to a control method, only the argument objects that are passed are usable.

19.6.7 BankField (Declare Bank/Data Field)

Syntax:

```
BankField (RegionName, BankName, BankValue, AccessType, LockRule,
UpdateRule) {FieldUnitList}
```

Arguments

RegionName is evaluated as a Namestring, and is the name of the host Operation Region.

BankName is evaluated as a Namestring, and is the name of the bank selection register.

BankValue is the bank selection ID (Integer) that is written to the *BankName* register before the *FieldUnitList* is accessed.

The *AccessType*, *LockRule*, *UpdateRule*, and *FieldUnitList* are the same format as the Field operator.

Description

Accessing the contents of a banked field data object will occur automatically through the proper bank setting, with synchronization occurring on the operation region that contains the *BankName* data variable, and on the Global Lock if specified by the *LockRule*.

This operator creates data field objects. The contents of the created objects are obtained by a reference to a bank selection register.

This encoding is used to define named data field objects whose data values are fields within a larger object selected by a bank-selected register.

Example

The following is a block of ASL sample code using BankField:

- Creates a 4-bit bank-selected register in system I/O space.
- Creates overlapping fields in the same system I/O space that are selected via the bank register.

```
//
// Define a 256-byte operational region in SystemIO space
// and name it GIO0

OperationRegion (GIO0, SystemIO, 0x125, 0x100)

// Create some fields in GIO including a 4-bit bank select register

Field (GIO0, ByteAcc, NoLock, Preserve) {
    GLB1, 1,
    GLB2, 1,
    Offset (1),           // Move to offset for byte 1
    BNK1, 4
}

// Create FET0 & FET1 in bank 0 at byte offset 0x30

BankField (GIO0, BNK1, 0, ByteAcc, NoLock, Preserve) {
    Offset (0x30),
    FET0, 1,
    FET1, 1
}

    // Create BLVL & BAC in bank 1 at the same offset

BankField (GIO0, BNK1, 1, ByteAcc, NoLock, Preserve) {
    Offset (0x30),
    BLVL, 7,
    BAC, 1
}
```

19.6.8 Break (Break from While)

Syntax:

```
Break
```

Description

Break causes execution to continue immediately following the innermost enclosing **While** or **Switch** scope, in the current Method. If there is no enclosing **While** or **Switch** within the current Method, a fatal error is generated.

Compatibility Note: In ACPI 1.0, the Break operator continued immediately following the innermost “code package.” Starting in ACPI 2.0, the Break operator was changed to exit the innermost “While” or “Switch” package. This should have no impact on existing code, since the ACPI 1.0 definition was, in practice, useless.

19.6.9 BreakPoint (Execution Break Point)

Syntax:

```
BreakPoint
```

Description

Used for debugging, the **Breakpoint** opcode stops the execution and enters the AML debugger. In the non-debug version of the AML interpreter, **BreakPoint** is equivalent to **Noop**.

19.6.10 Buffer (Declare Buffer Object)

Syntax:

```
Buffer (BufferSize) {Initializer} => Buffer
```

Arguments

Declares a Buffer of optional size *BufferSize* and an optional initial value of *Initializer*. The *Initializer* is must be either a *ByteList* or a *String*.

Description

The optional *BufferSize* argument specifies the size of the buffer and an optional initial value of the buffer is specified via the *Initializer*. The initial value can be either an ASCII String or a list of byte values separated by commas. Strings are automatically null terminated with a single zero byte.

The relationship between the *BufferSize* and the *Initializer* is summarized by the rules below.

In the typical case, the *BufferSize* is identical to the length of the *Initializer*:

```
Name (BUF0, Buffer(4) {0x01,0x02,0x03,0x04}) // Length = 4
```

If the *BufferSize* is not specified, the length of the *Initializer* is used as the buffer size:

```
Name (BUF1, Buffer() {0,1,2,3,4,5}) // Length = 6
Name (BUF2, Buffer() {"abcde"}) // Length = 6
```

If the *BufferSize* is larger than the length of the *Initializer*, the *BufferSize* is used as the final buffer size. At runtime, the AML interpreter will automatically pad zeros to the *Initializer* to match the *BufferSize*:

```
Name (BUF3, Buffer(1024) {4,5,6,7,8}) // Length = 1024
Name (BUF4, Buffer(1024) {"abcde"}) // Length = 1024
```

If the *BufferSize* is smaller than the length of the *Initializer*, the length of the *Initializer* is used as the buffer size:

```
Name (BUF5, Buffer(1) {5,4,3,2,1}) // Length = 5
```

If the *Initializer* is not specified, the AML interpreter creates a buffer containing all zeros, the length of which matches the *BufferSize*:

```
Name (BUF6, Buffer(32) {}) // Length = 32
```

If neither the *BufferSize* nor the *Initializer* are specified, a buffer of zero length is created:

```
Name (BUF7, Buffer() {}) // Length = 0
```

19.6.11 Case (Expression for Conditional Execution)

Syntax:

```
Case ( Value ) {TermList}
```

Arguments

Value specifies an Integer, Buffer, String or Package object. TermList is a sequence of executable ASL expressions.

Description

Execute code based upon the value of a Switch statement.

If the Case Value is an Integer, Buffer or String, then control passes to the statement that matches the value of the enclosing Switch (Value). If the Case value is a Package, then control passes if any member of the package matches the Switch (Value). The Switch CaseTermList can include any number of Case instances, but no two Case Values (or members of a Value, if Value is a Package) within the same Switch statement can contain the same value.

Execution of the statement body begins at the start of the TermList and proceeds until the end of the TermList body or until a Break or Continue operator transfers control out of the body.

19.6.12 Concatenate (Concatenate Data)

Syntax:

```
Concatenate ( Source1, Source2, Result ) => Buffer or String
```

Arguments

Source1 and Source2 must each evaluate to any valid ACPI object. For the basic data object types (Integer, String, or Buffer), the value of the object is used in the concatenation. For all other object types (see table below), a string object is created that contains the name (type) of the object. This string object is then concatenated according to the rules in *Concatenate Data Types*.

The data type of *Source1* dictates the required type of *Source2* and the type of the result object. *Source2* is implicitly converted if necessary (and possible) to match the type of *Source1*.

Description

Source2 is concatenated to Source1 and the result data is optionally stored into Result.

Table 19.30: Concatenate Data Types

Source1 Data Type	Source2 Data Type (Converted Type)	Result Data Type
Integer	Integer/String/Buffer → Integer	Buffer
String	Integer/String/Buffer /All other types → String	String
Buffer	Integer/String/Buffer /All other types → Buffer	Buffer
All other types → String	Integer/String/Buffer /All other types → String	String

For the *Source1* /Integer case, a String or Buffer that cannot be implicitly converted to an Integer will generate a fatal error.

Table 19.31: Concatenate Object Types

Data Object Type	Name	Resolved to Value
1	Integer	Integer value of the object
2	String	String value of the object
3	Buffer	Buffer value of the object
Other Object Types	Name	Resolved to String
0	Uninitialized	“[Uninitialized Object]”
4	Package	“[Package]”
5	Field Unit	“[Field]”
6	Device	“[Device]”
7	Event	“[Event]”
8	Control Method	“[Control Method]”
9	Mutex	“[Mutex]”
10	Operation Region	“[Operation Region]”
11	Power Resource	“[Power Resource]”
12	Processor	“[Processor]”
13	Thermal Zone	“[Thermal Zone]”
14	Buffer Field	“[Buffer Field]”
15	<i>Reserved</i>	
16	Debug Object	“[Debug Object]”

Examples:

```
Device (DEVX) {}
Name (PKGX, Package () {1,2,3,"Battery1"})

Method (MTHX, 2)
{
    Concatenate ("My Object: ", DEVX, Debug) // MyObject: Device

    Printf ("PKGX %o contains %o elements\n", PKGX, SizeOf (PKGX))

    Printf ("Arg0: %o\n", Arg0)
}
```

19.6.13 ConcatenateResTemplate (Concatenate Resource Templates)

Syntax:

```
ConcatenateResTemplate (Source1, Source2, Result) => Buffer
```

Arguments

Source1 and Source2 are evaluated as Resource Template buffers.

Description

The resource descriptors from Source2 are appended to the resource descriptors from Source1. Then a new end tag and checksum are appended and the result is stored in Result, if specified. If either Source1 or Source2 is exactly 1 byte in length, a run-time error occurs. An empty buffer is treated as a resource template with only an end tag.

19.6.14 CondRefOf (Create Object Reference Conditionally)

Syntax:

```
CondRefOf (Source, Result) => Boolean
```

Arguments

Attempts to create a reference to the Source object. The Source of this operation can be any object type (for example, data package, device object, and so on), and the result data is optionally stored into Result.

Description

On success, the Destination object is set to refer to Source and the execution result of this operation is the value True. On failure, Destination is unchanged and the execution result of this operation is the value False. This can be used to reference items in the namespace that may appear dynamically (for example, from a dynamically loaded definition block).

CondRefOf is equivalent to RefOf except that if the Source object does not exist, it is fatal for RefOf but not for CondRefOf.

19.6.15 Connection (Declare Field Connection Attributes)

Syntax:

```
Connection (ConnectionResourceObj)
```

Arguments

ConnectionResourceObj is a GPIO or Serial Bus Connection Descriptor depending on the Operation Region type, or a named object containing the Descriptor.

See Section 6.4.3.8.2 and *Field (Declare Field Objects)* for more information.

Examples:

```
OperationRegion(TOP1, GenericSerialBus, 0x00, 0x100)
                                     // GenericSerialBus device at command_
↪value offset zero

Name (I2C, ResourceTemplate() {
    I2CSerialBusV2(0x5a,,100000,, "\_SB.I2C",,,,,RawDataBuffer() {1,6})
})

Field(TOP1, BufferAcc, NoLock, Preserve)
{
    Connection(I2C)                    // Specify connection resource_
↪information
    AccessAs(BufferAcc, AttribWord)    // Use the GenericSerialBus
                                     // Read/Write Word protocol
    FLD0, 8,                            // Virtual register at command value 0.
    FLD1, 8,                            // Virtual register at command value 1.

Field(TOP1, BufferAcc, NoLock, Preserve)
{
    Connection(I2CSerialBusV2(0x5b,,100000,, "\_SB.I2C",,,,,RawDataBuffer() {3,9}))
    AccessAs(BufferAcc, AttribBytes (16))
    FLD2, 8                             // Virtual register at command value 0.
```

(continues on next page)

(continued from previous page)

```

}

// Create the GenericSerialBus data buffer
Name(BUFF, Buffer(34){})           // Create GenericSerialBus data buffer_
→as BUFF
CreateByteField(BUFF, 0x00, STAT) // STAT = Status (Byte)
CreateWordField(BUFF, 0x02, DATA) // DATA = Data (Word)

```

Description

The Connection macro declares the connection attributes for subsequent fields defined within the Field declaration.

19.6.16 Continue (Continue Innermost Enclosing While)**Syntax:**

```
Continue
```

Description

Continue causes execution to continue at the start of the innermost enclosing While scope, in the currently executing Control Method, at the point where the condition is evaluated. If there is no enclosing While within the current Method, a fatal error is generated.

19.6.17 CopyObject (Copy and Store Object)**Syntax:**

```
CopyObject (Source, Destination) => DataRefObject
```

Arguments

Converts the contents of the Source to a DataRefObject using the conversion rules in [Section 19.3.5](#) and then copies the results without conversion to the object referred to by Destination.

Description

If Destination is already an initialized object of type DataRefObject, the original contents of Destination are discarded and replaced with Source. Otherwise, a fatal error is generated.

Note: Compatibility Note: The CopyObject operator was first introduced new in ACPI 2.0.

19.6.18 CreateBitField (Create 1-Bit Buffer Field)**Syntax:**

```
CreateBitField (SourceBuffer, BitIndex, BitFieldName)
```

Arguments

SourceBuffer is evaluated as a buffer. *BitIndex* is evaluated as an integer. *BitFieldName* is a NameString.

Description

A new buffer field object named `BitFieldName` is created for the bit of `SourceBuffer` at the bit index of `BitIndex`. The bit-defined field within `SourceBuffer` must exist. `BitFieldName` is created for the bit of `SourceBuffer` at the bit index of `BitIndex`. The bit-defined field within `SourceBuffer` must exist.

19.6.19 CreateByteField (Create 8-Bit Buffer Field)

Syntax:

```
CreateByteField ( SourceBuffer, ByteIndex, ByteFieldName )
```

Arguments

SourceBuffer is evaluated as a buffer. *ByteIndex* is evaluated as an integer. *ByteFieldName* is a `NameString`.

Description

A new buffer field object named `ByteFieldName` is created for the byte of `SourceBuffer` at the byte index of `ByteIndex`. The byte-defined field within `SourceBuffer` must exist.

19.6.20 CreateDWordField (Create 32-Bit Buffer Field)

Syntax:

```
CreateDWordField ( SourceBuffer, ByteIndex, DWordFieldName )
```

Arguments

SourceBuffer is evaluated as a buffer. *ByteIndex* is evaluated as an integer. *DWordFieldName* is a `NameString`.

Description

A new buffer field object named `DWordFieldName` is created for the `DWord` of `SourceBuffer` at the byte index of `ByteIndex`. The `DWord`-defined field within `SourceBuffer` must exist.

19.6.21 CreateField (Create Arbitrary Length Buffer Field)

Syntax:

```
CreateField ( SourceBuffer, BitIndex, NumBits, FieldName )
```

Arguments

SourceBuffer is evaluated as a buffer. *BitIndex* and *NumBits* are evaluated as integers. *FieldName* is a `NameString`.

Description

A new buffer field object named `FieldName` is created for the bits of `SourceBuffer` at `BitIndex` for `NumBits`. The entire bit range of the defined field within `SourceBuffer` must exist. If `NumBits` evaluates to zero, a fatal exception is generated.

19.6.22 CreateQWordField (Create 64-Bit Buffer Field)

Syntax:

```
CreateQWordField ( SourceBuffer, ByteIndex, QWordFieldName )
```

Arguments

SourceBuffer is evaluated as a buffer. *ByteIndex* is evaluated as an integer. *QWordFieldName* is a *NameString*.

Description

A new buffer field object named *QWordFieldName* is created for the QWord of *SourceBuffer* at the byte index of *ByteIndex*. The QWord-defined field within *SourceBuffer* must exist.

19.6.23 CreateWordField (Create 16-Bit Buffer Field)

Syntax:

```
CreateWordField ( SourceBuffer, ByteIndex, WordFieldName )
```

Arguments

SourceBuffer is evaluated as a buffer. *ByteIndex* is evaluated as an integer. *WordFieldName* is a *NameString*.

Description

A new bufferfield object named *WordFieldName* is created for the word of *SourceBuffer* at the byte index of *ByteIndex*. The word-defined field within *SourceBuffer* must exist.

19.6.24 CSI2Bus (CSI-2 Serial Bus Connection Resource Descriptor Macro)

Syntax

CSI2Bus (*SlaveMode*, *PhyType*, *LocalPort*, *ResourceSource*, *ResourceSourceIndex*, *ResourceUsage*, *DescriptorName*, *VendorData*)

Arguments

SlaveMode is an optional argument and can be either *ControllerInitiated* or *DeviceInitiated*. *ControllerInitiated* is the default. The bit field name *_SLV* is automatically created to refer to this portion of the resource descriptor.

PhyType is an integer ranging from 0 to 3 specifying the value for the PHY Type. This value describes the PHY type used to connect this device to its receiver. *_PHY* is automatically created to refer to this portion of the resource descriptor.

LocalPort is an optional integer argument, that identifies the index of the local Port for this connection. The first Port instance is 0.

ResourceSource is a string which uniquely identifies the remote CSI-2 receiver referred to by this descriptor. *ResourceSource* can be a fully-qualified name, a relative name or a name segment that utilizes the namespace search rules.

ResourceSourceIndex is an integer specifying the Port index of the Device specified by *ResourceSource*. Port index values begin at 0.

ResourceUsage is an optional argument and is assumed to be *ResourceConsumer* for this revision.

DescriptorName is an optional argument that specifies a name for an integer constant that will be created in the current scope that contains the offset of this resource descriptor within the current resource template buffer. The predefined

descriptor field names may be appended to this name to access individual fields within the descriptor via the Buffer Field operators.

VendorData is an optional argument that specifies an object to be decoded by the OS driver. It is a RawDataBuffer. The bit field name `_VEN` is automatically created to refer to this portion of the resource descriptor.

Description

The CSI2Bus macro evaluates to a buffer that contains a CSI-2 resource descriptor. The macro is designed to be used inside of a ResourceTemplate (see Section 19.3.4).

19.6.25 DataTableRegion (Create Data Table Operation Region)

Syntax:

```
DataTableRegion ( RegionName, SignatureString, OemIDString, OemTableIDString )
```

Arguments

Creates a new region named RegionName. SignatureString, OemIDString and OemTableIDString are evaluated as strings.

Description

A Data Table Region is a special Operation Region whose RegionSpace is SystemMemory. Any table referenced by a Data Table Region must be in memory marked by AddressRangeReserved or AddressRangeNVS.

The memory referred to by the Data Table Region is the memory that is occupied by the table referenced in XSDT that is identified by SignatureString, OemIDString and OemTableIDString. Any Field object can reference RegionName

The base address of a Data Table region is the address of the first byte of the header of the table identified by SignatureString, OemIDString and OemTableIDString. The length of the region is the length of the table.

19.6.26 Debug (Debugger Output)

Syntax:

```
Debug
```

Description

The debug data object is a virtual data object. Writes to this object provide debugging information. On at least debug versions of the interpreter, any writes into this object are appropriately displayed on the system’s native kernel debugger. All writes to the debug object are otherwise benign. If the system is in use without a kernel debugger, then writes to the debug object are ignored. The following table relates the ASL term types that can be written to the Debug object to the format of the information on the kernel debugger display.

Table 19.32: Debug Object Display Formats

ASL Term Type	Display Format
Numeric data object	All digits displayed in hexadecimal format.
String data object	String is displayed.
Object reference	Information about the object is displayed (for example, object type and object name), but the object is not evaluated.

The Debug object is a write-only object; attempting to read from the debug object is not supported.

19.6.27 Decrement (Integer Decrement)

Syntax:

```
Decrement (Minuend) => Integer
Minuend -- => Integer
```

Arguments

Minuend is evaluated as an Integer.

Description

This operation decrements the *Minuend* by one and the result is stored back to *Minuend*. Equivalent to Subtract (*Minuend*, 1, *Minuend*). Underflow conditions are ignored and the result is Ones.

19.6.28 Default (Default Execution Path in Switch)

Syntax:

```
Default {TermList}
```

Arguments

TermList is a sequence of executable ASL expressions.

Description

Within the body of a *Switch (Select Code To Execute Based On Expression)* statement, the statements specified by *TermList* will be executed if no *Case (Expression for Conditional Execution)* statement value matches the Switch statement value. If Default is omitted and no Case match is found, none of the statements in the Switch body are executed. There can be at most one Default statement in the immediate scope of the parent Switch statement. The Default statement can appear anywhere in the body of the Switch statement.

19.6.29 DefinitionBlock (Declare Definition Block)

Syntax:

```
DefinitionBlock ( AMLFileName, TableSignature, ComplianceRevision, OEMID, TableID,   
↳ OEMRevision) {TermList}
```

Arguments

AMLFileName is a string that specifies the desired name of the translated output AML file. If the *AMLFileName* is a NULL (zero length) string, the ASL compiler will automatically create the filename (typically generated from the input filename/pathname). *TableSignature* is a string that contains the 4-character ACPI signature. *ComplianceRevision* is an 8-bit value. *OEMID* is a 6-character string, *TableId* is an 8-character string, and *OEMRevision* is a 32-bit value. *TermList* is a sequence of executable ASL expressions.

If multiple *DefinitionBlocks* are defined in the same ASL file, the first *DefinitionBlock* defines the output *AMLFileName* as per the rule above.

Description

The *DefinitionBlock* term specifies the unit of data and/or AML code that the OS will load as part of the Differentiated Definition Block or as part of an additional Definition Block.

This unit of data and/or AML code describes either the base system or some large extension (such as a docking station). The entire *DefinitionBlock* will be loaded and compiled by the OS as a single unit.

System software loads a definition block by referencing the objects in the TermList package in order. The object list is encoded as TermList, so that rather than describing a static object list, it is possible to describe a dynamic object list according to the system settings. See [Section 5.4.2](#).

Note: For compatibility with ACPI versions before ACPI 2.0, the bit width of Integer objects is dependent on the ComplianceRevision of the DSDT. If the ComplianceRevision is less than 2, all integers are restricted to 32 bits. Otherwise, full 64-bit integers are used. The version of the DSDT sets the global integer width for all integers, including integers in SSDTs.

19.6.30 DerefOf (Dereference an Object Reference)

Syntax:

```
DerefOf (Source) => Object
```

Arguments

Returns the object referred by the Source object reference.

Description

If the Source evaluates to an object reference, the actual contents of the object referred to are returned. If the Source evaluates to a string, the string is evaluated as an ASL name (relative to the current scope) and the contents of that object are returned. If the object specified by Source does not exist then a fatal error is generated. If the object specified is a reference generated by the Index() operator and refers to an uninitialized package element, then a fatal error is generated.

Note: Compatibility Note: The use of a String with DerefOf was first introduced in ACPI 2.0*.

19.6.31 Device (Declare Device Package)

Syntax:

```
Device (DeviceName) {TermList}
```

Arguments

Creates a Device object of name DeviceName, which represents a processor, a bus or a device, or any other similar hardware. Device opens a name scope.

Description

A Device Package is one of the basic ways the Differentiated Definition Block describes the hardware devices in the system to the operating software. Each Device Package is defined somewhere in the hierarchical namespace corresponding to that device's location in the system. Within the namespace of the device are other names that provide information and control of the device, along with any sub-devices that in turn describe sub-devices, and so on.

For any device, the platform runtime firmware provides only information that is added to the device in a non-hardware standard manner. This type of value-added function is expressible in the ACPI Definition Block such that operating software can use the function.

The platform runtime firmware supplies Device Objects only for devices that are obtaining some system-added function outside the device's normal capabilities and for any Device Object required to fill in the tree for such a device. For example, if the system includes a PCI device (integrated or otherwise) with no additional functions such as power management, the platform runtime firmware would not report such a device; however, if the system included an integrated ISA device below the integrated PCI device (device is an IS bridge), then the system would include a Device Package

for the ISA device with the minimum feature being added being the ISA device's ID and configuration information and the parent PCI device, because it is required to get the ISA Device Package placement in the namespace correct.

The device object list is encoded as *TermList*, so that rather than describing a static device object list, it is possible to describe a dynamic device object list according to the system settings. see [Section 5.4.2](#).

Example

The following block of ASL sample code shows a nested use of Device objects to describe an IDE controller connected to the root PCI bus:

```
Device (IDE0) { // primary controller
    Name (_ADR, 0) // put PCI Address (device/function) here

    // define region for IDE mode register

    OperationRegion (PCIC, PCI_Config, 0x50, 0x10)
    Field (PCIC, AnyAcc, NoLock, Preserve) {
        ...
    }
    Device (PRIM) { // Primary adapter
        Name (_ADR, 0) // Primary adapter = 0
        ...
        Method (_STM, 2) {
            ...
        }
        Method (_GTM) {
            ...
        }
    }

    Device (MSTR) { // master channel
        Name (_ADR, 0)
        Name (_PR0, Package () {0, PIDE})

        Name (_GTF) {
            ...
        }
    }
    Device (SLAV) {
        Name (_ADR, 1)
        Name (_PR0, Package () {0, PIDE})
        Name (_GTF) {
            ...
        }
    }
}
}
```

19.6.32 Divide (Integer Divide)

Syntax:

```
Divide (Dividend, Divisor, Remainder, Result) => Integer
Result = Dividend / Divisor=> Integer
Result /= Divisor => Integer
```

Arguments

Dividend and *Divisor* are evaluated as Integers.

Description

Dividend is divided by Divisor, then the resulting remainder is optionally stored into Remainder and the resulting quotient is optionally stored into Result. Divide-by-zero exceptions are fatal.

The function return value is the Result (quotient).

19.6.33 DMA (DMA Resource Descriptor Macro)**Syntax:**

```
DMA ( DmaType , IsBusMaster , DmaTransferSize, DescriptorName )
{ DmaChannelList } => Buffer
```

Arguments

DmaType specifies the type of DMA cycle: ISA compatible (Compatibility), EISA Type A (TypeA), EISA Type B (TypeB) or EISA Type F (TypeF). The 2-bit field *DescriptorName._TYP* is automatically created to refer to this portion of the resource descriptor, where '0' is Compatibility, '1' is TypeA, '2' is TypeB and '3' is TypeF.

IsBusMaster specifies whether this device can generate DMA bus master cycles (BusMaster) or not (NotBusMaster). If nothing is specified, then BusMaster is assumed. The 1-bit field *DescriptorName._BM* is automatically created to refer to this portion of the resource descriptor, where '0' is NotBusMaster and '1' is BusMaster.

DmaTransferSize specifies the size of DMA cycles the device is capable of generating: 8-bit (Transfer8), 16-bit (Transfer16) or both 8 and 16-bit (Transfer8_16). The 2-bit field *DescriptorName._SIZ* is automatically created to refer to this portion of the resource descriptor, where '0' is Transfer8, '1' is Transfer8_16 and '2' is Transfer16.

DescriptorName is an optional argument that specifies a name for an integer constant that will be created in the current scope that contains the offset of this resource descriptor within the current resource template buffer. The predefined descriptor field names may be appended to this name to access individual fields within the descriptor via the Buffer Field operators.

DmaChannelList is a comma-delimited list of integers in the range 0 through 7 that specify the DMA channels used by the device. There may be no duplicates in the list.

Description

The DMA macro evaluates to a buffer that contains a DMA resource descriptor. The format of this resource descriptor can be found in *DMA Descriptor*. This macro is designed to be used inside of a *ResourceTemplate (Resource To Buffer Conversion Macro)*.

19.6.34 DWordIO (DWord IO Resource Descriptor Macro)**Syntax:**

```
DWordIO ( ResourceUsage, IsMinFixed, IsMaxFixed, Decode, ISARanges,
AddressGranularity, AddressMinimum, AddressMaximum, AddressTranslation,
RangeLength, ResourceSourceIndex, ResourceSource, DescriptorName,
TranslationType, TranslationDensity)
```

Arguments

ResourceUsage specifies whether the I/O range is consumed by this device (ResourceConsumer) or passed on to child devices (ResourceProducer). If nothing is specified, then ResourceConsumer is assumed.

IsMinFixed specifies whether the minimum address of this I/O range is fixed (MinFixed) or can be changed (MinNotFixed). If nothing is specified, then MinNotFixed is assumed. The 1-bit field *DescriptorName._MIF* is automatically created to refer to this portion of the resource descriptor, where '1' is MinFixed and '0' is MinNotFixed.

IsMaxFixed specifies whether the maximum address of this I/O range is fixed (MaxFixed) or can be changed (MaxNotFixed). If nothing is specified, then MaxNotFixed is assumed. The 1-bit field *DescriptorName._MAF* is automatically created to refer to this portion of the resource descriptor, where '1' is MaxFixed and '0' is MaxNotFixed.

Decode specifies whether or not the device decodes the I/O range using positive (PosDecode) or subtractive (SubDecode) decode. If nothing is specified, then PosDecode is assumed. The 1-bit field *DescriptorName._DEC* is automatically created to refer to this portion of the resource descriptor, where '1' is SubDecode and '0' is PosDecode.

ISARanges specifies whether the I/O ranges specifies are limited to valid ISA I/O ranges (ISAOnly), valid non-ISA I/O ranges (NonISAOnly) or encompass the whole range without limitation (EntireRange). The 2-bit field *DescriptorName._RNG* is automatically created to refer to this portion of the resource descriptor, where '1' is NonISAOnly, '2' is ISAOnly and '0' is EntireRange.

AddressGranularity evaluates to a 32-bit integer that specifies the power-of-two boundary (- 1) on which the I/O range must be aligned. The 32-bit field *DescriptorName._GRA* is automatically created to refer to this portion of the resource descriptor.

AddressMinimum evaluates to a 32-bit integer that specifies the lowest possible base address of the I/O range. The value must have '0' in all bits where the corresponding bit in *AddressGranularity* is '1'. For bridge devices which translate addresses, this is the address on the secondary bus. The 32-bit field *DescriptorName._MIN* is automatically created to refer to this portion of the resource descriptor.

AddressMaximum evaluates to a 32-bit integer that specifies the highest possible base address of the I/O range. The value must have '0' in all bits where the corresponding bit in *AddressGranularity* is '1'. For bridge devices which translate addresses, this is the address on the secondary bus. The 32-bit field *DescriptorName._MAX* is automatically created to refer to this portion of the resource descriptor.

AddressTranslation evaluates to a 32-bit integer that specifies the offset to be added to a secondary bus I/O address which results in the corresponding primary bus I/O address. For all non-bridge devices or bridges which do not perform translation, this must be '0'. The 32-bit field *DescriptorName._TRA* is automatically created to refer to this portion of the resource descriptor.

RangeLength evaluates to a 32-bit integer that specifies the total number of bytes decoded in the I/O range. The 32-bit field *DescriptorName._LEN* is automatically created to refer to this portion of the resource descriptor.

ResourceSourceIndex is an optional argument which evaluates to an 8-bit integer that specifies the resource descriptor within the object specified by *ResourceSource*. If this argument is specified, the *ResourceSource* argument must also be specified.

ResourceSource is an optional argument which evaluates to a string containing the path of a device which produces the pool of resources from which this I/O range is allocated. If this argument is specified, but the *ResourceSourceIndex* argument is not specified, a value of zero is assumed.

DescriptorName is an optional argument that specifies a name for an integer constant that will be created in the current scope that contains the offset of this resource descriptor within the current resource template buffer. The predefined descriptor field names may be appended to this name to access individual fields within the descriptor via the Buffer Field operators.

TranslationType is an optional argument that specifies whether the resource type on the secondary side of the bus is different (TypeTranslation) from that on the primary side of the bus or the same (TypeStatic). If TypeTranslation is specified, then the primary side of the bus is Memory. If TypeStatic is specified, then the primary side of the bus is I/O. If nothing is specified, then TypeStatic is assumed. The 1-bit field *DescriptorName._TTP* is automatically created to refer to this portion of the resource descriptor, where '1' is TypeTranslation and '0' is TypeStatic. see [Table 6.49](#) for more information.

TranslationDensity is an optional argument that specifies whether or not the translation from the primary to secondary bus is sparse (SparseTranslation) or dense (DenseTranslation). It is only used when *TranslationType* is TypeTranslation. If nothing is specified, then DenseTranslation is assumed. The 1-bit field *DescriptorName._TRS* is automatically created to refer to this portion of the resource descriptor, where '1' is *SparseTranslation* and '0' is *DenseTranslation*. see [Table 6.50](#) for more information.

Description

The DWordIO macro evaluates to a buffer that contains a 32-bit I/O range resource descriptor. The format of the 32-bit I/O range resource descriptor can be found in Table 6.46. This macro is designed to be used inside of a *ResourceTemplate (Resource To Buffer Conversion Macro)*.

19.6.35 DWordMemory (DWord Memory Resource Descriptor Macro)**Syntax:**

```
DWordMemory (ResourceUsage, Decode, IsMinFixed, IsMaxFixed, Cacheable,
ReadAndWrite, AddressGranularity, AddressMinimum, AddressMaximum,
AddressTranslation, RangeLength, ResourceSourceIndex, ResourceSource,
DescriptorName, MemoryRangeType, TranslationType)
```

Arguments

ResourceUsage specifies whether the Memory range is consumed by this device (ResourceConsumer) or passed on to child devices (ResourceProducer). If nothing is specified, then ResourceConsumer is assumed.

Decode specifies whether or not the device decodes the Memory range using positive (PosDecode) or subtractive (SubDecode) decode. If nothing is specified, then PosDecode is assumed. The 1-bit field DescriptorName._DEC is automatically created to refer to this portion of the resource descriptor, where '1' is SubDecode and '0' is PosDecode.

IsMinFixed specifies whether the minimum address of this Memory range is fixed (MinFixed) or can be changed (MinNotFixed). If nothing is specified, then MinNotFixed is assumed. The 1-bit field DescriptorName._MIF is automatically created to refer to this portion of the resource descriptor, where '1' is MinFixed and '0' is MinNotFixed.

IsMaxFixed specifies whether the maximum address of this Memory range is fixed (MaxFixed) or can be changed (MaxNotFixed). If nothing is specified, then MaxNotFixed is assumed. The 1-bit field DescriptorName._MAF is automatically created to refer to this portion of the resource descriptor, where '1' is MaxFixed and '0' is MaxNotFixed.

Cacheable specifies whether or not the memory region is cacheable (Cacheable), cacheable and write-combining (WriteCombining), cacheable and prefetchable (Prefetchable) or uncacheable (NonCacheable). If nothing is specified, then NonCacheable is assumed. The 2-bit field DescriptorName._MEM is automatically created to refer to this portion of the resource descriptor, where '1' is Cacheable, '2' is WriteCombining, '3' is Prefetchable and '0' is NonCacheable.

ReadAndWrite specifies whether or not the memory region is read-only (ReadOnly) or read/write (ReadWrite). If nothing is specified, then ReadWrite is assumed. The 1-bit field DescriptorName._RW is automatically created to refer to this portion of the resource descriptor, where '1' is ReadWrite and '0' is ReadOnly.

AddressGranularity evaluates to a 32-bit integer that specifies the power-of-two boundary (- 1) on which the Memory range must be aligned. The 32-bit field DescriptorName._GRA is automatically created to refer to this portion of the resource descriptor.

AddressMinimum evaluates to a 32-bit integer that specifies the lowest possible base address of the Memory range. The value must have '0' in all bits where the corresponding bit in AddressGranularity is '1'. For bridge devices which translate addresses, this is the address on the secondary bus. The 32-bit field DescriptorName._MIN is automatically created to refer to this portion of the resource descriptor.

AddressMaximum evaluates to a 32-bit integer that specifies the highest possible base address of the Memory range. The value must have '0' in all bits where the corresponding bit in AddressGranularity is '1'. For bridge devices which translate addresses, this is the address on the secondary bus. The 32-bit field DescriptorName._MAX is automatically created to refer to this portion of the resource descriptor.

AddressTranslation evaluates to a 32-bit integer that specifies the offset to be added to a secondary bus I/O address which results in the corresponding primary bus I/O address. For all non-bridge devices or bridges which do not perform translation, this must be '0'. The 32-bit field DescriptorName._TRA is automatically created to refer to this portion of the resource descriptor.

RangeLength evaluates to a 32-bit integer that specifies the total number of bytes decoded in the Memory range. The 32-bit field *DescriptorName._LEN* is automatically created to refer to this portion of the resource descriptor.

ResourceSourceIndex is an optional argument which evaluates to an 8-bit integer that specifies the resource descriptor within the object specified by *ResourceSource*. If this argument is specified, the *ResourceSource* argument must also be specified.

ResourceSource is an optional argument which evaluates to a string containing the path of a device which produces the pool of resources from which this Memory range is allocated. If this argument is specified, but the *ResourceSourceIndex* argument is not specified, a zero value is assumed.

DescriptorName is an optional argument that specifies a name for an integer constant that will be created in the current scope that contains the offset of this resource descriptor within the current resource template buffer. The predefined descriptor field names may be appended to this name to access individual fields within the descriptor via the Buffer Field operators.

MemoryRangeType is an optional argument that specifies the memory usage. The memory can be marked as normal (*AddressRangeMemory*), used as ACPI NVS space (*AddressRangeNVS*), used as ACPI reclaimable space (*AddressRangeACPI*) or as system reserved (*AddressRangeReserved*). If nothing is specified, then *AddressRangeMemory* is assumed. The 2-bit field *DescriptorName._MTP* is automatically created in order to refer to this portion of the resource descriptor, where '0' is *AddressRangeMemory*, '1' is *AddressRangeReserved*, '2' is *AddressRangeACPI* and '3' is *AddressRangeNVS*.

TranslationType is an optional argument that specifies whether the resource type on the secondary side of the bus is different (*TypeTranslation*) from that on the primary side of the bus or the same (*TypeStatic*). If *TypeTranslation* is specified, then the primary side of the bus is I/O. If *TypeStatic* is specified, then the primary side of the bus is Memory. If nothing is specified, then *TypeStatic* is assumed. The 1-bit field *DescriptorName._TTP* is automatically created to refer to this portion of the resource descriptor, where '1' is *TypeTranslation* and '0' is *TypeStatic*. see [Table 6.50](#) for more information.

Description

The *DWordMemory* macro evaluates to a buffer which contains a 32-bit memory resource descriptor. The format of the 32-bit memory resource descriptor can be found in *DWORD Address Space Descriptor Definition*. This macro is designed to be used inside of a *ResourceTemplate (Resource To Buffer Conversion Macro)*.

19.6.36 DWordSpace (DWord Space Resource Descriptor Macro)

Syntax:

```
DWordSpace (ResourceType, ResourceUsage, Decode, IsMinFixed, IsMaxFixed,
TypeSpecificFlags, AddressGranularity, AddressMinimum, AddressMaximum,
AddressTranslation, RangeLength, ResourceSourceIndex, ResourceSource,
DescriptorName)
```

Arguments

ResourceType evaluates to an 8-bit integer that specifies the type of this resource. Acceptable values are 0xC0 through 0xFF.

ResourceUsage specifies whether the Memory range is consumed by this device (*ResourceConsumer*) or passed on to child devices (*ResourceProducer*). If nothing is specified, then *ResourceConsumer* is assumed.

Decode specifies whether or not the device decodes the Memory range using positive (*PosDecode*) or subtractive (*SubDecode*) decode. If nothing is specified, then *PosDecode* is assumed. The 1-bit field *DescriptorName._DEC* is automatically created to refer to this portion of the resource descriptor, where '1' is *SubDecode* and '0' is *PosDecode*.

IsMinFixed specifies whether the minimum address of this Memory range is fixed (MinFixed) or can be changed (MinNotFixed). If nothing is specified, then MinNotFixed is assumed. The 1-bit field DescriptorName._MIF is automatically created to refer to this portion of the resource descriptor, where '1' is MinFixed and '0' is MinNotFixed.

IsMaxFixed specifies whether the maximum address of this Memory range is fixed (MaxFixed) or can be changed (MaxNotFixed). If nothing is specified, then MaxNotFixed is assumed. The 1-bit field DescriptorName._MAF is automatically created to refer to this portion of the resource descriptor, where '1' is MaxFixed and '0' is MaxNotFixed.

TypeSpecificFlags evaluates to an 8-bit integer. The flags are specific to the Resource Type.

AddressGranularity evaluates to a 32-bit integer that specifies the power-of-two boundary (- 1) on which the Memory range must be aligned. The 32-bit field DescriptorName._GRA is automatically created to refer to this portion of the resource descriptor.

AddressMinimum evaluates to a 32-bit integer that specifies the lowest possible base address of the Memory range. The value must have '0' in all bits where the corresponding bit in AddressGranularity is '1'. For bridge devices which translate addresses, this is the address on the secondary bus. The 32-bit field DescriptorName._MIN is automatically created to refer to this portion of the resource descriptor.

AddressMaximum evaluates to a 32-bit integer that specifies the highest possible base address of the Memory range. The value must have '0' in all bits where the corresponding bit in AddressGranularity is '1'. For bridge devices which translate addresses, this is the address on the secondary bus. The 32-bit field DescriptorName._MAX is automatically created to refer to this portion of the resource descriptor.

AddressTranslation evaluates to a 32-bit integer that specifies the offset to be added to a secondary bus I/O address which results in the corresponding primary bus I/O address. For all non-bridge devices or bridges which do not perform translation, this must be '0'. The 32-bit field DescriptorName._TRA is automatically created to refer to this portion of the resource descriptor.

RangeLength evaluates to a 32-bit integer that specifies the total number of bytes decoded in the Memory range. The 32-bit field DescriptorName._LEN is automatically created to refer to this portion of the resource descriptor.

ResourceSourceIndex is an optional argument which evaluates to an 8-bit integer that specifies the resource descriptor within the object specified by ResourceSource. If this argument is specified, the ResourceSource argument must also be specified.

ResourceSource is an optional argument which evaluates to a string containing the path of a device which produces the pool of resources from which this Memory range is allocated. If this argument is specified, but the ResourceSourceIndex argument is not specified, a zero value is assumed.

DescriptorName is an optional argument that specifies a name for an integer constant that will be created in the current scope that contains the offset of this resource descriptor within the current resource template buffer. The predefined descriptor field names may be appended to this name to access individual fields within the descriptor via the Buffer Field operators.

Description

The DWordSpace macro evaluates to a buffer which contains a 32-bit Address Space resource descriptor. The format of this resource descriptor can be found in *DWORD Address Space Descriptor*. This macro is designed to be used inside of a *ResourceTemplate (Resource To Buffer Conversion Macro)*.

19.6.37 EISAID (EISA ID String To Integer Conversion Macro)

Syntax:

```
EISAID ( EisaIdString ) => DWordConst
```

Arguments

The EisaIdString must be a String object of the form “UUUNNNN”, where “U” is an uppercase letter and “N” is a hexadecimal digit. No asterisks or other characters are allowed in the string.

Description

Converts EisaIdString, a 7-character text string argument, into its corresponding 4-byte numeric EISA ID encoding. It can be used when declaring IDs for devices that have EISA IDs.

Example

```
EISAID ("PNP0C09") // This is a valid invocation of the macro.
```

19.6.38 Else (Alternate Execution)

Syntax:

```
Else {TermList}
```

Arguments

TermList is a sequence of executable ASL statements.

Description

If Predicate evaluates to 0 in an If statement, then control is transferred to the Else portion, which can consist of zero or more ElseIf statements followed by zero or one Else statements. If the Predicate of any ElseIf statement evaluates to non-zero, the statements in its term list are executed and then control is transferred past the end of the final Else term. If no Predicate evaluates to non-zero, then the statements in the Else term list are executed.

Example

The following example checks Local0 to be zero or non-zero. On non-zero, CNT is incremented; otherwise, CNT is decremented:

```
If (LGreater (Local0, 5)
{
    Increment (CNT)
}
Else If (Local0) {
    Add (CNT, 5, CNT)
}
Else
{
    Decrement (CNT)
}
```

19.6.39 ElseIf (Alternate/Conditional Execution)

Syntax:

```
ElseIf ( Predicate ) {TermList}
```

Arguments

Predicate is evaluated as an Integer.

Description

If the Predicate of any ElseIf statement evaluates to non-zero, the statements in its term list are executed and then control is transferred past the end of the final Else. If no Predicate evaluates to non-zero, then the statements in the Else term list are executed.

Note: Compatibility Note: The ElseIf operator was first introduced in ACPI 2.0, but is backward compatible with the ACPI 1.0 specification. An ACPI 2.0 and later ASL compiler must synthesize ElseIf from the If and Else opcodes available in 1.0. For example:

```
If (predicate1)
{
    ...statements1...
}
ElseIf (predicate2)
{
    ...statements2...
}
Else
{
    ...statements3...
}
```

is translated to the following:

```
If (predicate1)
{
    ...statements1...
}
Else
{
    If (predicate2)
    {
        ...statements2...
    }
    Else
    {
        ...statements3...
    }
}
```

19.6.40 EndDependentFn (End Dependent Function Resource Descriptor Macro)

Syntax:

```
EndDependentFn ( ) => Buffer
```

Description

The `EndDependentFn` macro generates an end-of-dependent-function resource descriptor buffer inside of a *ResourceTemplate* (*Resource To Buffer Conversion Macro*). This descriptor must be matched with a *StartDependentFn* (*Start Dependent Function Resource Descriptor Macro*) or a *StartDependentFnNoPri* (*Start Dependent Function Resource Descriptor Macro*).

19.6.41 Event (Declare Event Synchronization Object)

Syntax:

```
Event ( EventName )
```

Arguments

Creates an event synchronization object named `EventName`.

Description

For more information about the uses of an event synchronization object, see the ASL definitions for the `Wait`, `Signal`, and `Reset` function operators.

19.6.42 ExtendedIO (Extended IO Resource Descriptor Macro)

Syntax:

```
ExtendedIO ( ResourceUsage, IsMinFixed , IsMaxFixed , Decode ,
ISARanges , AddressGranularity, AddressMinimum, AddressMaximum ,
AddressTranslation , RangeLength , TypeSpecificAttributes,
DescriptorName, TranslationType, TranslationDensity)
```

Arguments

ResourceUsage specifies whether the Memory range is consumed by this device (`ResourceConsumer`) or passed on to child devices (`ResourceProducer`). If nothing is specified, then `ResourceConsumer` is assumed.

IsMinFixed specifies whether the minimum address of this I/O range is fixed (`MinFixed`) or can be changed (`MinNotFixed`). If nothing is specified, then `MinNotFixed` is assumed. The 1-bit field `DescriptorName._MIF` is automatically created to refer to this portion of the resource descriptor, where '1' is `MinFixed` and '0' is `MinNotFixed`.

IsMaxFixed specifies whether the maximum address of this I/O range is fixed (`MaxFixed`) or can be changed (`MaxNotFixed`). If nothing is specified, then `MaxNotFixed` is assumed. The 1-bit field `DescriptorName._MAF` is automatically created to refer to this portion of the resource descriptor, where '1' is `MaxFixed` and '0' is `MaxNotFixed`.

Decode specifies whether or not the device decodes the I/O range using positive (`PosDecode`) or subtractive (`SubDecode`) decode. If nothing is specified, then `PosDecode` is assumed. The 1-bit field `DescriptorName._DEC` is automatically created to refer to this portion of the resource descriptor, where '1' is `SubDecode` and '0' is `PosDecode`.

ISARanges specifies whether the I/O ranges specifies are limited to valid ISA I/O ranges (`ISAOnly`), valid non-ISA I/O ranges (`NonISAOnly`) or encompass the whole range without limitation (`EntireRange`). The 2-bit field `DescriptorName._RNG` is automatically created to refer to this portion of the resource descriptor, where '1' is `NonISAOnly`, '2' is `ISAOnly` and '0' is `EntireRange`.

AddressGranularity evaluates to a 64-bit integer that specifies the power-of-two boundary (- 1) on which the I/O range must be aligned. The 64-bit field *DescriptorName._GRA* is automatically created to refer to this portion of the resource descriptor.

AddressMinimum evaluates to a 64-bit integer that specifies the lowest possible base address of the I/O range. The value must have '0' in all bits where the corresponding bit in *AddressGranularity* is '1'. For bridge devices which translate addresses, this is the address on the secondary bus. The 64-bit field *DescriptorName._MIN* is automatically created to refer to this portion of the resource descriptor.

AddressMaximum evaluates to a 64-bit integer that specifies the highest possible base address of the I/O range. The value must have '0' in all bits where the corresponding bit in *AddressGranularity* is '1'. For bridge devices which translate addresses, this is the address on the secondary bus. The 64-bit field *DescriptorName._MAX* is automatically created to refer to this portion of the resource descriptor.

AddressTranslation evaluates to a 64-bit integer that specifies the offset to be added to a secondary bus I/O address which results in the corresponding primary bus I/O address. For all non-bridge devices or bridges which do not perform translation, this must be '0'. The 64-bit field *DescriptorName._TRA* is automatically created to refer to this portion of the resource descriptor.

RangeLength evaluates to a 64-bit integer that specifies the total number of bytes decoded in the I/O range. The 64-bit field *DescriptorName._LEN* is automatically created to refer to this portion of the resource descriptor.

Type Specific Attributes is an optional argument that specifies attributes specific to this resource type.

DescriptorName is an optional argument that specifies a name for an integer constant that will be created in the current scope that contains the offset of this resource descriptor within the current resource template buffer. The predefined descriptor field names may be appended to this name to access individual fields within the descriptor via the Buffer Field operatorsDescription

The *ExtendedIO* macro evaluates to a buffer that contains a 64-bit I/O resource descriptor, which describes a range of I/O addresses. The format of this resource descriptor can be found in [Section 6.4.3.5.4](#). This macro is designed to be used inside of a *ResourceTemplate (Resource To Buffer Conversion Macro)*.

TranslationType is an optional argument that specifies whether the resource type on the secondary side of the bus is different (*TypeTranslation*) from that on the primary side of the bus or the same (*TypeStatic*). If *TypeTranslation* is specified, then the primary side of the bus is Memory. If *TypeStatic* is specified, then the primary side of the bus is I/O. If nothing is specified, then *TypeStatic* is assumed. The 1-bit field *DescriptorName._TTP* is automatically created to refer to this portion of the resource descriptor, where '1' is *TypeTranslation* and '-0'-is-*TypeStatic*. See [Section 5.6.8](#) for more information.

TranslationDensity is an optional argument that specifies whether or not the translation from the primary to secondary bus is sparse (*SparseTranslation*) or dense (*DenseTranslation*). It is only used when *TranslationType* is *TypeTranslation*. If nothing is specified, then *DenseTranslation* is assumed. The 1-bit field *DescriptorName._TRS* is automatically created to refer to this portion of the resource descriptor, where '1' is *SparseTranslation* and '0' is *DenseTranslation*. See [Section 5.6.8](#) for more information.

19.6.43 ExtendedMemory (Extended Memory Resource Descriptor Macro)

Syntax:

```
ExtendedMemory ( ResourceUsage, Decode, IsMinFixed, IsMaxFixed,
Cacheable, ReadAndWrite, AddressGranularity, AddressMinimum,
AddressMaximum, AddressTranslation, RangeLength, TypeSpecificAttributes,
DescriptorName, MemoryRangeType, TranslationType)
```

Arguments

ResourceUsage specifies whether the Memory range is consumed by this device (*ResourceConsumer*) or passed on to child devices (*ResourceProducer*). If nothing is specified, then *ResourceConsumer* is assumed.

Decode specifies whether or not the device decodes the Memory range using positive (PosDecode) or subtractive (SubDecode) decode. If nothing is specified, then PosDecode is assumed. The 1-bit field DescriptorName._DEC is automatically created to refer to this portion of the resource descriptor, where '1' is SubDecode and '0' is PosDecode.

IsMinFixed specifies whether the minimum address of this Memory range is fixed (MinFixed) or can be changed (MinNotFixed). If nothing is specified, then MinNotFixed is assumed. The 1-bit field DescriptorName._MIF is automatically created to refer to this portion of the resource descriptor, where '1' is MinFixed and '0' is MinNotFixed.

IsMaxFixed specifies whether the maximum address of this Memory range is fixed (MaxFixed) or can be changed (MaxNotFixed). If nothing is specified, then MaxNotFixed is assumed. The 1-bit field DescriptorName._MAF is automatically created to refer to this portion of the resource descriptor, where '1' is MaxFixed and '0' is MaxNotFixed.

Cacheable specifies whether or not the memory region is cacheable (Cacheable), cacheable and write-combining (WriteCombining), cacheable and prefetchable (Prefetchable) or uncacheable (NonCacheable). If nothing is specified, then NonCacheable is assumed. The 2-bit field DescriptorName._MEM is automatically created to refer to this portion of the resource descriptor, where '1' is Cacheable, '2' is WriteCombining, '3' is Prefetchable and '0' is NonCacheable.

ReadAndWrite specifies whether or not the memory region is read-only (ReadOnly) or read/write (ReadWrite). If nothing is specified, then ReadWrite is assumed. The 1-bit field DescriptorName._RW is automatically created to refer to this portion of the resource descriptor, where '1' is ReadWrite and '0' is ReadOnly.

AddressGranularity evaluates to a 64-bit integer that specifies the power-of-two boundary (- 1) on which the Memory range must be aligned. The 64-bit field DescriptorName._GRA is automatically created to refer to this portion of the resource descriptor.

AddressMinimum evaluates to a 64-bit integer that specifies the lowest possible base address of the Memory range. The value must have '0' in all bits where the corresponding bit in AddressGranularity is '1'. For bridge devices which translate addresses, this is the address on the secondary bus. The 64-bit field DescriptorName._MIN is automatically created to refer to this portion of the resource descriptor.

AddressMaximum evaluates to a 64-bit integer that specifies the highest possible base address of the Memory range. The value must have '0' in all bits where the corresponding bit in AddressGranularity is '1'. For bridge devices which translate addresses, this is the address on the secondary bus. The 64-bit field DescriptorName._MAX is automatically created to refer to this portion of the resource descriptor.

AddressTranslation evaluates to a 64-bit integer that specifies the offset to be added to a secondary bus I/O address which results in the corresponding primary bus I/O address. For all non-bridge devices or bridges which do not perform translation, this must be '0'. The 64-bit field DescriptorName._TRA is automatically created to refer to this portion of the resource descriptor.

RangeLength evaluates to a 64-bit integer that specifies the total number of bytes decoded in the Memory range. The 64-bit field DescriptorName._LEN is automatically created to refer to this portion of the resource descriptor.

Type Specific Attributes is an optional argument that specifies attributes specific to this resource type.

DescriptorName is an optional argument that specifies a name for an integer constant that will be created in the current scope that contains the offset of this resource descriptor within the current resource template buffer. The predefined descriptor field names may be appended to this name to access individual fields within the descriptor via the Buffer Field operators.

MemoryRangeType is an optional argument that specifies the memory usage. The memory can be marked as normal (AddressRangeMemory), used as ACPI NVS space (AddressRangeNVS), used as ACPI reclaimable space (AddressRangeACPI) or as system reserved (AddressRangeReserved). If nothing is specified, then AddressRangeMemory is assumed. The 2-bit field DescriptorName._MTP is automatically created in order to refer to this portion of the resource descriptor, where '0' is AddressRangeMemory, '1' is AddressRangeReserved, '2' is AddressRangeACPI and '3' is AddressRangeNVS.

TranslationType is an optional argument that specifies whether the resource type on the secondary side of the bus is different (TypeTranslation) from that on the primary side of the bus or the same (TypeStatic). If TypeTranslation is specified, then the primary side of the bus is I/O. If TypeStatic is specified, then the primary side of the bus is Memory.

If nothing is specified, then `TypeStatic` is assumed. The 1-bit field `DescriptorName._TTP` is automatically created to refer to this portion of the resource descriptor, where '1' is `TypeTranslation` and '0' is `TypeStatic`. See [Section 5.6.8](#) for more information.

Description

The `ExtendedMemory` macro evaluates to a buffer that contains a 64-bit memory resource descriptor, which describes a range of memory addresses. The format of this resource descriptor can be found in [Section 6.4.3.5.4](#). This macro is designed to be used inside of a *ResourceTemplate (Resource To Buffer Conversion Macro)*.

19.6.44 ExtendedSpace (Extended Address Space Resource Descriptor Macro)

Syntax:

```
ExtendedSpace (ResourceType, ResourceUsage, Decode, IsMinFixed,
IsMaxFixed, TypeSpecificFlags, AddressGranularity, AddressMinimum,
AddressMaximum, AddressTranslation, RangeLength, TypeSpecificAttributes,
DescriptorName)
```

Arguments

ResourceType evaluates to an 8-bit integer that specifies the type of this resource. Acceptable values are 0xC0 through 0xFF.

ResourceUsage specifies whether the Memory range is consumed by this device (`ResourceConsumer`) or passed on to child devices (`ResourceProducer`). If nothing is specified, then `ResourceConsumer` is assumed.

Decode specifies whether or not the device decodes the Memory range using positive (`PosDecode`) or subtractive (`SubDecode`) decode. If nothing is specified, then `PosDecode` is assumed. The 1-bit field `DescriptorName._DEC` is automatically created to refer to this portion of the resource descriptor, where '1' is `SubDecode` and '0' is `PosDecode`.

IsMinFixed specifies whether the minimum address of this Memory range is fixed (`MinFixed`) or can be changed (`MinNotFixed`). If nothing is specified, then `MinNotFixed` is assumed. The 1-bit field `DescriptorName._MIF` is automatically created to refer to this portion of the resource descriptor, where '1' is `MinFixed` and '0' is `MinNotFixed`.

IsMaxFixed specifies whether the maximum address of this Memory range is fixed (`MaxFixed`) or can be changed (`MaxNotFixed`). If nothing is specified, then `MaxNotFixed` is assumed. The 1-bit field `DescriptorName._MAF` is automatically created to refer to this portion of the resource descriptor, where '1' is `MaxFixed` and '0' is `MaxNotFixed`.

TypeSpecificFlags evaluates to an 8-bit integer. The flags are specific to the `ResourceType`.

AddressGranularity evaluates to a 64-bit integer that specifies the power-of-two boundary (- 1) on which the Memory range must be aligned. The 64-bit field `DescriptorName._GRA` is automatically created to refer to this portion of the resource descriptor.

AddressMinimum evaluates to a 64-bit integer that specifies the lowest possible base address of the Memory range. The value must have '0' in all bits where the corresponding bit in `AddressGranularity` is '1'. For bridge devices which translate addresses, this is the address on the secondary bus. The 64-bit field `DescriptorName._MIN` is automatically created to refer to this portion of the resource descriptor.

AddressMaximum evaluates to a 64-bit integer that specifies the highest possible base address of the Memory range. The value must have '0' in all bits where the corresponding bit in `AddressGranularity` is '1'. For bridge devices which translate addresses, this is the address on the secondary bus. The 64-bit field `DescriptorName._MAX` is automatically created to refer to this portion of the resource descriptor.

AddressTranslation evaluates to a 64-bit integer that specifies the offset to be added to a secondary bus I/O address which results in the corresponding primary bus I/O address. For all non-bridge devices or bridges which do not perform translation, this must be '0'. The 64-bit field `DescriptorName._TRA` is automatically created to refer to this portion of the resource descriptor.

RangeLength evaluates to a 64-bit integer that specifies the total number of bytes decoded in the Memory range. The 64-bit field *DescriptorName*. *_LEN* is automatically created to refer to this portion of the resource descriptor.

Type Specific Attributes is an optional argument that specifies attributes specific to this resource type.

DescriptorName is an optional argument that specifies a name for an integer constant that will be created in the current scope that contains the offset of this resource descriptor within the current resource template buffer. The predefined descriptor field names may be appended to this name to access individual fields within the descriptor via the Buffer Field operators.

Description

The *ExtendedSpace* macro evaluates to a buffer that contains a 64-bit Address Space resource descriptor, which describes a range of addresses. The format of the 64-bit AddressSpace descriptor can be found in Section 6.4.3.5.4. This macro is designed to be used inside of a *ResourceTemplate (Resource To Buffer Conversion Macro)*.

19.6.45 External (Declare External Objects)

Syntax:

```
External ( ObjectName, ObjectType, ReturnType, ParameterTypes )
```

Arguments

ObjectName is a NameString.

ObjectType is an optional *ObjectTypeKeyword* (e.g. *IntObj*, *PkgObj*, etc.). If not specified, “UnknownObj” type is assumed.

ReturnType is optional. If the specified *ObjectType* is *MethodObj*, then this specifies the type or types of object returned by the method. If the method does not return an object, then nothing is specified or *UnknownObj* is specified. To specify a single return type, simply use the *ObjectTypeKeyword*. To specify multiple possible return types, enclose the comma-separated *ObjectTypeKeywords* with braces. For example: {*IntObj*, *BuffObj*}.

ParameterTypes is optional. If the specified *ObjectType* is *MethodObj*, this specifies both the number and type of the method parameters. It is a comma-separated, variable-length list of the expected object type or types for each of the method parameters, enclosed in braces. For each parameter, the parameter type consists of either an *ObjectTypeKeyword* or a comma-separated sub-list of *ObjectTypeKeywords* enclosed in braces. There can be no more than seven parameters in total.

The *External* directive informs the ASL compiler that the object is declared external to this table so that no errors will be generated for an undeclared object. The ASL compiler will create the external object at the specified place in the namespace (if a full path of the object is specified), or the object will be created at the current scope of the *External* term.

For external control methods, the ASL compiler can emit an *External* AML opcode that contains the name of the method and the number of required arguments. This information may be used by AML disassemblers to properly disassemble the AML to the correct ASL code.

External is especially useful for use in secondary SSDTs, when the required scopes and objects are declared in the main DSDT.

Example

This example shows the use of *External* in conjunction with *Scope* within an SSDT:

```
DefinitionBlock ("ssdt.aml", "SSDT", 2, "X", "Y", 0x00000001)
{
    External (\_SB.PCI0, DeviceObj)
```

(continues on next page)

(continued from previous page)

```
Scope (\_SB.PCI0)
{
}
}
```

19.6.46 Fatal (Fatal Error Check)

Syntax:

```
Fatal ( Type, Code, Arg )
```

Arguments

This operation is used to inform the OS that there has been an OEM-defined fatal error.

Description

In response, the OS must log the fatal event and perform a controlled OS shutdown in a timely fashion.

19.6.47 Field (Declare Field Objects)

Syntax:

```
Field ( RegionName, AccessType, LockRule, UpdateRule ) {FieldUnitList}
```

Arguments

RegionName is evaluated as a Namestring that refers to the host operation region.

AccessType is optional and defines the default access width of the field definition and is any one of the following: AnyAcc, ByteAcc, WordAcc, DWordAcc, or QWordAcc. In general, accesses within the parent object are performed naturally aligned. If desired, *AccessType* set to a value other than AnyAcc can be used to force minimum access width. Notice that the parent object must be able to accommodate the *AccessType* width. For example, an access type of WordAcc cannot read the last byte of an odd-length operation region. The exceptions to natural alignment are the access types used for a non-linear SMBus device. These will be discussed in detail below. Not all access types are meaningful for every type of operational region. If not specified, the default is AnyAcc.

LockRule is optional and indicates whether the Global Lock is to be used when accessing this field and is one of the following: Lock or NoLock. If *LockRule* is set to Lock, accesses to modify the component data objects will acquire and release the Global Lock. If both types of locking occur, the Global Lock is acquired after the parent object Mutex. On Hardware-reduced ACPI platforms, Lock is not supported. If not specified, the default is NoLock.

UpdateRule is optional and specifies how the unmodified bits of a field are treated, and can be any one of the following: Preserve, WriteAsOnes, or WriteAsZeros. For example, if a field defines a component data object of 4 bits in the middle of a WordAcc region, when those 4 bits are modified the *UpdateRule* specifies how the other 12 bits are treated. If not specified, the default is Preserve.

FieldUnitList is a variable-length list of individual field unit definitions, separated by commas. Each entry in the field unit list is one of the following:

Table 19.33: Field Unit List Entries

FieldUnitName (BitLength)
Offset (<i>ByteOffset</i>)
AccessAs (<i>AccessType, AccessAttribute</i>)

continues on next page

Table 19.33 – continued from previous page

FieldUnitName (BitLength)
Connection (<i>ConnectionResourceObj</i>)

FieldUnitName is the ACPI name for the field unit (1 to 4 characters), and BitLength is the length of the field unit in bits. Offset is used to specify the byte offset of the next defined field unit. This can be used instead of defining the bit lengths that need to be skipped. AccessAs is used to define the access type and attributes for the remaining field units within the list. Connection is used to identify the connection resource of the field access. This is necessary for GenericSerialBus and GeneralPurposeIO operation region address spaces only.

Description

Declares a series of named data objects whose data values are fields within a larger object. The fields are parts of the object named by RegionName, but their names appear in the same scope as the Field term.

For example, the field operator allows a larger operation region that represents a hardware register to be broken down into individual bit fields that can then be accessed by the bit field names. Extracting and combining the component field from its parent is done automatically when the field is accessed.

When reading from a FieldUnit, returned values are normalized (shifted and masked to the proper length.) The data type of an individual FieldUnit can be either a Buffer or an Integer, depending on the bit length of the FieldUnit. If the FieldUnit is smaller than or equal to the size of an Integer (in bits), it will be treated as an Integer. If the FieldUnit is larger than the size of an Integer, it will be treated as a Buffer. The size of an Integer is indicated by the DSDT header’s Revision field. A revision less than 2 indicates that the size of an Integer is 32 bits. A value greater than or equal to 2 signifies that the size of an Integer is 64 bits. For more information about data types and FieldUnit type conversion rules, see Section 19.3.5.7 .

Accessing the contents of a field data object provides access to the corresponding field within the parent object. If the parent object supports Mutex synchronization, accesses to modify the component data objects will acquire and release ownership of the parent object around the modification.

The following table relates region types declared with an OperationRegion term to the different access types supported for each region.

Table 19.34: OperationRegion Address Spaces and Access Types

Address Space	Permitted Access Type(s)	Description
SystemMemory	ByteAcc, WordAcc, DWordAcc, QWordAcc, or AnyAcc	All access allowed
SystemIO	ByteAcc, WordAcc, DWordAcc, QWordAcc, or AnyAcc	All access allowed
PCI_Config	ByteAcc, WordAcc, DWordAcc, QWordAcc, or AnyAcc	All access allowed
EmbeddedControl	ByteAcc	Byte access only
SMBus	BufferAcc	Reads and writes to this operation region involve the use of a region specific data buffer. (See below.)
SystemCMOS	ByteAcc	Byte access only
PciBarTarget	ByteAcc, WordAcc, DWordAcc, QWordAcc, or AnyAcc	All access allowed
IPMI	BufferAcc	Reads and writes to this operation region involve the use of a region specific data buffer. (See below.)
GeneralPurposeIO	ByteAcc	Byte access only
GenericSerialBus	BufferAcc	Reads and writes to this operation region involve the use of a region-specific data buffer. (See below.)
PCC	ByteAcc	Reads and writes to this operation region are performed in units of bytes.

The named FieldUnit data objects are provided in the FieldList as a series of names and bit widths. Bits assigned no name (or NULL) are skipped. The ASL compiler supports the Offset (ByteOffset) macro within a FieldList to skip to the bit position of the supplied byte offset, and the AccessAs macro to change access within the field list.

GenericSerialBus, SMBus and IPMI regions are inherently non-linear, where each offset within the respective address space represents a variable sized (0 to 32 bytes) field. Given this uniqueness, these operation regions include restrictions on their field definitions and require the use of a region-specific data buffer when initiating transactions. For more information on the SMBus data buffer format see [Section 13.2.5](#). For more information on the IPMI data buffer format, see [Section 5.5.2.4.5](#). For more information on the GenericSerialBus data buffer format, see [Section 5.5.2.4.7](#).

For restrictions on the use of Fields with GeneralPurposeIO OpRegions, see [Section 5.5.2.4.6](#).

Example:

```
OperationRegion (MIOC, PCI_Config, Zero, 0xFF)
Field (MIOC, AnyAcc, NoLock, Preserve)
{
    Offset (0x58),
    HXGB, 32,
    HXGT, 32,
    GAPE, 8,
    MROA, 4,
    MROB, 4
}
```

19.6.48 FindSetLeftBit (Find First Set Left Bit)

Syntax:

```
FindSetLeftBit ( Source, Result ) => Integer
```

Arguments

Source is evaluated as an Integer.

Description

The one-based bit location of the first MSb (most significant set bit) is optionally stored into Result. The result of 0 means no bit was set, 1 means the left-most bit set is the first bit, 2 means the left-most bit set is the second bit, and so on.

19.6.49 FindSetRightBit (Find First Set Right Bit)

Syntax:

```
FindSetRightBit ( Source, Result ) => Integer
```

Arguments

Source is evaluated as an Integer.

Description

The one-based bit location of the most LSb (least significant set bit) is optionally stored in Result. The result of 0 means no bit was set, 32 means the first bit set is the thirty-second bit, 31 means the first bit set is the thirty-first bit, and so on.

19.6.50 FixedDMA (DMA Resource Descriptor Macro)

Syntax:

```
FixedDMA ( DmaRequestLine, Channel, DmaTransferWidth, DescriptorName ) => Buffer
```

Arguments

DmaRequestLine is a system-relative number uniquely identifying the request line statically assigned to the device.. The bit field name `_DMA` is automatically created to refer to this portion of the resource descriptor.

Channel is a controller-relative number uniquely identifying the channel statically assigned to this `DmaRequestLine`. Channels can be shared by reusing Channel numbers across descriptors. The bit field name `_TYP` is automatically created to refer to this portion of the resource descriptor.

DmaTransferWidth is an optional argument specifying the width of data transfer for which the device is configured. Valid values are `Width8Bit`, `Width16Bit`, `Width32Bit`, `Width64Bit`, `Width128Bit` or `Width256Bit`. If not specified, `Width32Bit` is assumed. The bit field name `_SIZ` is automatically created to refer to this portion of the resource descriptor.

DescriptorName is an optional argument that specifies a name for an integer constant that will be created in the current scope that contains the offset of this resource descriptor within the current resource template buffer. The predefined descriptor field names may be appended to this name to access individual fields within the descriptor via the Buffer Field operators.

Description

The `FixedDMA` macro evaluates to a buffer that contains a *Fixed DMA Descriptor*. This macro is designed to be used inside of a *ResourceTemplate (Resource To Buffer Conversion Macro)*.

19.6.51 FixedIO (Fixed IO Resource Descriptor Macro)

Syntax:

```
FixedIO ( AddressBase, RangeLength, DescriptorName ) => Buffer
```

Arguments

AddressBase evaluates to a 16-bit integer. It describes the starting address of the fixed I/O range. The field `DescriptorName`. `_BAS` is automatically created to refer to this portion of the resource descriptor.

RangeLength evaluates to an 8-bit integer. It describes the length of the fixed I/O range. The field `DescriptorName`. `_LEN` is automatically created to refer to this portion of the resource descriptor.

DescriptorName evaluates to a name string which refers to the entire resource descriptor.

Description

The `FixedIO` macro evaluates to a buffer that contains a fixed I/O resource descriptor. The format of this resource descriptor can be found in Section 6.4.2.6. This macro is designed to be used inside of a *ResourceTemplate (Resource To Buffer Conversion Macro)*.

19.6.52 For (Conditional Loop)

Syntax:

```
For ( Initialize, Predicate, Update ) {TermList}
```

Arguments

Initialize. This optional expression is evaluated once before the loop is entered. If not specified, no initialization takes place.

Predicate. The list of terms within the TermList are executed until the predicate evaluates to zero (FALSE). If this argument is not specified, the For macro is equivalent to *While(1)*.

Update. This optional expression is evaluated once per execution of the loop, after all other terms within the TermList have been executed.

Description

For is a macro that creates a loop by converting the input arguments to the equivalent ASL *While* loop.

Note: Creation of a named object more than once in a given scope is not allowed. As such, unconditionally creating named objects within a For loop must be avoided. A fatal error will be generated on the second iteration of the loop, during the attempt to create the same named object a second time.

Example

The following example shows the use of the *For* macro to create a loop, followed by the equivalent *While* loop that is actually emitted by the ASL compiler:

```
for (local0 = 0, local0 < 8, local0++)
{
}

Local0 = 0
While (Local0 < 8)
{
    Local0++
}
```

19.6.53 Fprintf (Create and Store formatted string)

Syntax:

```
Fprintf ( Destination, FormatString, FormatArgs ) => String
```

Arguments

Fprintf is a macro that converts the evaluated *FormatString* into a series of string *Concatenate* operations, storing the result in *Destination*.

FormatString is a string literal which may contain one or more uses of the format specifier, *%o*, to indicate locations in the string where an object may be inserted. *%o* is the only format specifier supported since the resulting object is a string and type conversion is handled automatically by *Concatenate*.

FormatArgs is a comma separated list of Named Objects, Locals, or Args that can be evaluated to a string. Each argument is added to the *FormatString* using the *Concatenate* operation at the location specified by *%o* in order of appearance.

Description

Fprintf is a macro that converts the evaluated FormatString into a series of string Concatenate operations, storing the result in Destination

Example

The following ASL example uses *Fprintf* to write a formatted string of Arg0 and Arg1 to the Named Object STR1:

```
Fprintf (STR1, "%o: %o Successful", Arg1, Arg0)
```

This Fprintf macro expression evaluates to the following ASL operation.

```
Store (Concatenate (Concatenate (Concatenate (Concatenate ("", Arg1), ": "), Arg0), "␣  
↪Successful"), STR1)
```

19.6.54 FromBCD (Convert BCD To Integer)

Syntax:

```
FromBCD ( BCDValue, Result ) => Integer
```

Arguments

BCDValue is evaluated as an Integer in Binary Coded Decimal format.

Description

The FromBCD operation *converts BCDValue to a numeric format, and optionally stores the numeric value into Result.*

19.6.55 Function (Declare Control Method)

Syntax:

```
Function ( FunctionName, ReturnType, ParameterTypes ) {TermList}
```

Arguments

ReturnType is optional and specifies the type(s) of the object(s) returned by the method. If the method does not return an object, then nothing is specified or UnknownObj is specified. To specify a single return type, simply use the *ObjectTypeKeyword* (e.g. IntObj, PkgObj, etc.). To specify multiple possible return types, enclose the comma-separated *ObjectTypeKeywords* with braces. For example:

```
{IntObj, BuffObj}.
```

ParameterTypes is optional and specifies both the number and type of the method parameters. It is a comma-separated, variable-length list of the expected object type or types for each of the method parameters, enclosed in braces. For each parameter, the parameter type consists of either an *ObjectTypeKeyword* or a comma-separated sub-list of *ObjectTypeKeywords* enclosed in braces. There can be no more than seven parameters in total.

Description

Function declares a named package containing a series of terms that collectively represent a control method. A control method is a procedure that can be invoked to perform computation. Function opens a name scope.

System software executes a control method by executing the terms in the package in order. For more information on method execution, see [Section 5.5.2](#).

The current namespace location used during name creation is adjusted to be the current location on the namespace tree. Any names created within this scope are “below” the name of this package. The current namespace location

is assigned to the method package, and all namespace references that occur during control method execution for this package are relative to that location.

Functions are equivalent to a Method that specifies NotSerialized. As such, a function should not create any named objects, since a second thread that might re-enter the function will cause a fatal error if an attempt is made to create the same named object twice.

Note: Compatibility Note: New for ACPI 3.0

Example

The following block of ASL sample code shows the use of Function for defining a control method:

```
Function (EXAM, IntObj, {StrObj, {IntObj, StrObj}})
{
    Name (Temp, "")
    Store (Arg0, Temp)           // could have used Arg1
    Return (SizeOf (Concatenate (Arg1, Temp)))
}
```

This declaration is equivalent to:

```
Method (EXAM, 2, NotSerialized, 0, IntObj, {StrObj, {IntObj, StrObj}})
{
    ...
}
```

19.6.56 GpioInt (GPIO Interrupt Connection Resource Descriptor Macro)

Syntax:

```
GpioInt (EdgeLevel, ActiveLevel, Shared, PinConfig, DebounceTimeout,
ResourceSource, ResourceSourceIndex, ResourceUsage, DescriptorName,
VendorData) {PinList}
```

Arguments

EdgeLevel can be either Edge or Level. The bit field name *_MOD* is automatically created to refer to this portion of the resource descriptor.

ActiveLevel can be one of ActiveHigh, ActiveLow or ActiveBoth. ActiveBoth can be specified only if EdgeLevel is Edge. The bit field name *_POL* is automatically created to refer to this portion of the resource descriptor.

Shared is an optional argument and can be one of Shared, Exclusive, SharedAndWake or ExclusiveAndWake. If not specified, Exclusive is assumed. The “Wake” designation indicates that the interrupt is capable of waking the system from a low-power idle state or a system sleep state. The bit field name *_SHR* is automatically created to refer to this portion of the resource descriptor.

PinConfig can be one of PullDefault, PullUp, PullDown, PullNone or a vendor-supplied value in the range 128-255. The bit field name *_PPI* is automatically created to refer to this portion of the resource descriptor.

DebounceTimeout is an optional argument specifying the debounce wait time, in hundredths of milliseconds. The bit field name *_DBT* is automatically created to refer to this portion of the resource descriptor.

ResourceSource is a string which uniquely identifies the GPIO controller referred to by this descriptor. ResourceSource can be a fully-qualified name, a relative name or a name segment that utilizes the namespace search rules.

ResourceSourceIndex is an optional argument and is assumed to be 0 for this revision.

ResourceUsage is an optional argument and is assumed to be ResourceConsumer for this revision.

DescriptorName is an optional argument that specifies a name for an integer constant that will be created in the current scope that contains the offset of this resource descriptor within the current resource template buffer. The predefined descriptor field names may be appended to this name to access individual fields within the descriptor via the Buffer Field operators.

VendorData is an optional argument that specifies a RawDataBuffer containing vendor-defined byte data to be decoded by the OS driver. The bit field name *_VEN* is automatically created to refer to this portion of the resource descriptor.

PinList is a list of (zero-based) pin numbers on the ResourceSource that are described by this descriptor. For interrupt pin descriptors, only one pin is allowed. The bit field name *_PIN* is automatically created to refer to this portion of the resource descriptor.

Description

The *GpioInt* macro evaluates to a buffer that contains a GPIO Interrupt Connection resource descriptor. The format of this resource descriptor can be found in Section 6.4.3.8.1. This macro is designed to be used inside of a *ResourceTemplate* (*Resource To Buffer Conversion Macro*).

19.6.57 GpioIo (GPIO Connection IO Resource Descriptor Macro)

Syntax:

```
GpioIo (Shared, PinConfig, DebounceTimeout, DriveStrength,
IORestriction, ResourceSource, ResourceSourceIndex, ResourceUsage,
DescriptorName, VendorData) {PinList}
```

Arguments

Shared is an optional argument and can be either Shared or Exclusive. If not specified, Exclusive is assumed. The bit field name *_SHR* is automatically created to refer to this portion of the resource descriptor.

PinConfig can be one of PullDefault, PullUp, PullDown, PullNone or a vendor-supplied value in the range 128-255. The bit field name *_PPI* is automatically created to refer to this portion of the resource descriptor.

DebounceTimeout is an optional argument specifying the hardware debounce wait time, in hundredths of milliseconds. The bit field name *_DBT* is automatically created to refer to this portion of the resource descriptor.

DriveStrength is an optional argument specifying the output drive capability of the pin, in hundredths of milliamperes. The bit field name *_DRS* is automatically created to refer to this portion of the resource descriptor.

IORestriction is an optional argument and can be IoRestrictionInputOnly, IoRestrictionOutputOnly, IoRestrictionNone, or IoRestrictionNoneAndPreserve. IORestrictions limit the mode in which the pin can be accessed (Input or Output). They also ensure that the pin configuration is preserved during periods when the driver is unloaded or the resource has been disconnected by the driver. If not specified, IoRestrictionNone is assumed. The bit field name *_IOR* is automatically created to refer to this portion of the resource descriptor.

ResourceSource is a string which uniquely identifies the GPIO controller referred to by this descriptor. ResourceSource can be a fully-qualified name, a relative name or a name segment that utilizes the namespace search rules.

ResourceSourceIndex is an optional argument and is always 0 for this revision.

ResourceUsage is an optional argument and is always ResourceConsumer for this revision.

DescriptorName is an optional argument that specifies a name for an integer constant that will be created in the current scope that contains the offset of this resource descriptor within the current resource template buffer. The predefined descriptor field names may be appended to this name to access individual fields within the descriptor via the Buffer Field operators.

VendorData is an optional argument that specifies a *RawDataBuffer* containing vendor-defined byte data to be decoded by the OS driver. The bit field name *_VEN* is automatically created to refer to this portion of the resource descriptor.

PinList is a list of pin numbers on the *ResourceSource* that are described by this descriptor. The bit field name *_PIN* is automatically created to refer to this portion of the resource descriptor.

Description

The *GpioIo* macro evaluates to a buffer that contains a GPIO IO Connection resource descriptor. The format of this resource descriptor can be found in *GPIO Connection Descriptor*. This macro is designed to be used inside of a *ResourceTemplate (Resource To Buffer Conversion Macro)*

19.6.58 I2CSerialBusV2 (I2C Serial Bus Connection Resource Descriptor (Version 2) Macro)

Syntax:

```
I2CSerialBusV2 (SlaveAddress, SlaveMode, ConnectionSpeed,
AddressingMode, ResourceSource, ResourceSourceIndex, ResourceUsage,
DescriptorName, Shared, VendorData)
```

Arguments

SlaveAddress is the I2C bus address for this connection. The bit field name *_ADR* is automatically created to refer to this portion of the resource descriptor.

SlaveMode is an optional argument and can be either *ControllerInitiated* or *DeviceInitiated*. *ControllerInitiated* is the default. The bit field name *_SLV* is automatically created to refer to this portion of the resource descriptor.

ConnectionSpeed is the maximum connection speed supported by this connection, in hertz. The bit field name *_SPE* is automatically created to refer to this portion of the resource descriptor.

AddressingMode is an optional argument and can be either *AddressingMode7Bit* or *AddressingMode10Bit*. *AddressingMode7Bit* is the default. The bit field name *_MOD* is automatically created to refer to this portion of the resource descriptor.

ResourceSource is a string which uniquely identifies the I2C bus controller referred to by this descriptor. *ResourceSource* can be a fully-qualified name, a relative name or a name segment that utilizes the namespace search rules.

ResourceSourceIndex is an optional argument and is assumed to be 0 for this revision.

ResourceUsage is an optional argument and is assumed to be *ResourceConsumer* for this revision.

DescriptorName is an optional argument that specifies a name for an integer constant that will be created in the current scope that contains the offset of this resource descriptor within the current resource template buffer. The predefined descriptor field names may be appended to this name to access individual fields within the descriptor via the *Buffer Field operators*.

Shared is an optional argument and can be either **Shared** or **Exclusive**. If not specified, **Exclusive** is assumed. The bit field name *_SHR* is automatically created to refer to this portion of the resource descriptor. This was added in ACPI 6.1, and changed *I2CSerialBus* to *I2CSerialBusV2*.

VendorData is an optional argument that specifies an object to be decoded by the OS driver. It is a *RawDataBuffer*. The bit field name *_VEN* is automatically created to refer to this portion of the resource descriptor.

Description

The *I2CSerialBusV2* macro evaluates to a buffer that contains an *I2C Serial Bus Connection Resource Descriptor*. This macro is designed to be used inside of a *ResourceTemplate (Resource To Buffer Conversion Macro)*.

19.6.59 If (Conditional Execution)

Syntax:

```
If ( Predicate ) {TermList}
```

Arguments

Predicate is evaluated as an Integer.

Description

If the Predicate is non-zero, the term list of the If term is executed.

Example

The following examples all check for bit 3 in Local0 being set, and clear it if set:

```
// example 1
If (And (Local0, 4))
{
  XOr (Local0, 4, Local0)
}

// example 2
Store (4, Local2)
If (And (Local0, Local2))
{
  XOr (Local0, Local2, Local0)
}
```

19.6.60 Include (Include Additional ASL File)

Syntax:

```
Include (FilePathName)
```

Arguments

FilePathname is a StringData data type that contains the full OS file system path.

Description

Include another file that contains ASL terms to be inserted in the current file of ASL terms. The file must contain elements that are grammatically correct in the current scope.

Example:

```
Include ("dataobj.asl")
```

19.6.61 Increment (Integer Increment)

Syntax:

```
Increment (Addend) => Integer
```

Destination = *Source* [*Index*] => *ObjectReference*

Addend ++ => *Integer*

Arguments

Addend is evaluated as an *Integer*.

Description

Add one to the *Addend* and place the result back in *Addend*. Equivalent to *Add* (*Addend*, 1, *Addend*). Overflow conditions are ignored and the result of an overflow is zero.

19.6.62 Index (Indexed Reference To Member Object)

Syntax:

```
Index (Source, Index, Destination) => ObjectReference
```

Destination = *Source* [*Index*] => *ObjectReference*

Arguments

Source is evaluated to a buffer, string, or package data type. *Index* is evaluated to an integer. The reference to the *n*th object (where *n* = *Index*) within *Source* is optionally stored as a reference into *Destination*.

Description

When *Source* evaluates to a *Buffer*, *Index* returns a reference to a *Buffer Field* containing the *n*th byte in the buffer. When *Source* evaluates to a *String*, *Index* returns a reference to a *Buffer Field* containing the *n*th character in the string. When *Source* evaluates to a *Package*, *Index* returns a reference to the *n*th object in the package.

19.6.62.1 Index with Packages

The following example ASL code shows a way to use the *Index* term to store into a local variable the sixth element of the first package of a set of nested packages:

```
Name (IO0D, Package () {
    Package () {
        0x01, 0x03F8, 0x03F8, 0x01, 0x08, 0x01, 0x25, 0xFF, 0xFE, 0x00, 0x00
    },
    Package () {
        0x01, 0x02F8, 0x02F8, 0x01, 0x08, 0x01, 0x25, 0xFF, 0xBE, 0x00, 0x00
    },
    Package () {
        0x01, 0x03E8, 0x03E8, 0x01, 0x08, 0x01, 0x25, 0xFF, 0xFA, 0x00, 0x00
    },
    Package () {
        x01, 0x02E8, 0x02E8, 0x01, 0x08, 0x01, 0x25, 0xFF, 0xBA, 0x00, 0x00
    },
    Package () {
        0x01, 0x0100, 0x03F8, 0x08, 0x08, 0x02, 0x25, 0x20, 0x7F, 0x00, 0x00
    }
})
```

(continues on next page)

(continued from previous page)

```

    }
  })

  // Get the 6th element of the first package

  Store (DeRefOf (Index (DeRefOf (Index (IOOD, 0)), 5)), Local0)

```

Note: DeRefOf is necessary in the first operand of the Store operator in order to get the actual object, rather than just a reference to the object. If DeRefOf were not used, then Local0 would contain an object reference to the sixth element in the first package rather than the number 1.*

19.6.62.2 Index with Buffers

The following example ASL code shows a way to store into the third byte of a buffer:

```

Name (BUFF, Buffer () {0x01, 0x02, 0x03, 0x04, 0x05})
// Store 0x55 into the third byte of the buffer
Store (0x55, Index (BUFF, 2))

```

The Index operator returns a reference to an 8-bit Buffer Field (similar to that created using CreateByteField).

If Source is evaluated to a buffer data type, the ObjectReference refers to the byte at Index within Source. If Source is evaluated to a buffer data type, a Store operation will only change the byte at Index within Source.

The following example ASL code shows the results of a series of Store operations:

```

Name (SRCB, Buffer () {0x10, 0x20, 0x30, 0x40})
Name (BUFF, Buffer () {0x1, 0x2, 0x3, 0x4})

```

The following will store 0x78 into the 3rd byte of the destination buffer:

```

Store (0x12345678, Index (BUFF, 2))

```

The following will store 0x10 into the 2nd byte of the destination buffer:

```

Store (SRCB, Index (BUFF, 1))

```

The following will store 0x41 (an 'A') into the 4th byte of the destination buffer:

```

Store ("ABCDEFGH", Index (BUFF, 3))

```

Note: Compatibility Note: First introduced in ACPI 2.0. In ACPI 1.0, the behavior of storing data larger than 8-bits into a buffer using Index was undefined.

19.6.62.3 Index with Strings

The following example ASL code shows a way to store into the 3rd character in a string:

```
Name (STR, "ABCDEFGHijkl")
// Store 'H' (0x48) into the third character to the string
Store ("H", Index (STR, 2))
```

The Index operator returns a reference to an 8-bit Buffer Field (similar to that created using CreateByteField).

Note: Compatibility Note: First introduced in ACPI 2.0.

19.6.63 IndexField (Declare Index/Data Fields)

Syntax:

```
IndexField (IndexName, DataName, AccessType, LockRule, UpdateRule) {FieldUnitList}
```

Arguments

IndexName is evaluated as a Namestring and refers to a Field Unit object.

DataName is evaluated as a Namestring and refers to a Field Unit object.

AccessType, *LockRule*, *UpdateRule*, and *FieldList* are the same format as the Field term.

Description

Creates a series of named data objects whose data values are fields within a larger object accessed by an index/data-style reference to *IndexName* and *DataName*.

This encoding is used to define named data objects whose data values are fields within an index/data register pair. This provides a simple way to declare register variables that occur behind a typical index and data register pair.

Accessing the contents of an indexed field data object will automatically occur through the *DataName* object by using an *IndexName* object aligned on an *AccessType* boundary, with synchronization occurring on the operation region that contains the index data variable, and on the Global Lock if specified by *LockRule*.

The value written to the *IndexName* register is defined to be a byte offset that is aligned on an *AccessType* boundary. For example, if *AccessType* is *DWordAcc*, valid index values are 0, 4, 8, etc. This value is always a byte offset and is independent of the width or access type of the *DataName* register.

Example

The following example contains a block of ASL sample code using *IndexField*, that:

- (a) Creates an index/data register in system I/O space made up of 8-bit registers.
- (b) Creates a FET0 field within the indexed range.

```
Method (EX1) {
    // Define a 256-byte operational region in SystemIO space
    // and name it GI00

    OperationRegion (GI00, 1, 0x125, 0x100)

    // Create a field named Preserve structured as a sequence
    // of index and data bytes
```

(continues on next page)

(continued from previous page)

```

Field (GIO0, ByteAcc, NoLock, WriteAsZeros) {
    IDX0, 8,
    DAT0, 8,
    .
    .
    .
}
// Create an IndexField within IDX0 & DAT0 which has
// FETs in the first two bits of indexed offset 0,
// and another 2 FETs in the high bit on indexed
// 2F and the low bit of indexed offset 30

IndexField (IDX0, DAT0, ByteAcc, NoLock, Preserve) {
    FET0, 1,
    FET1, 1,
    Offset (0x2f),           // skip to byte offset 2f
    , 7,                     // skip another 7 bits
    FET3, 1,
    FET4, 1
}

// Clear FET3 (index 2F, bit 7)

Store (Zero, FET3)

} // End EX1

```

19.6.64 Interrupt (Interrupt Resource Descriptor Macro)

Syntax:

```

Interrupt ( ResourceUsage, EdgeLevel, ActiveLevel, Shared,
ResourceSourceIndex, ResourceSource, DescriptorName ) { InterruptList
} => Buffer

```

Arguments

ResourceUsage describes whether the device consumes the specified interrupt (ResourceConsumer) or produces it for use by a child device (ResourceProducer). If nothing is specified, then ResourceConsumer is assumed.

EdgeLevel describes whether the interrupt is edge triggered (Edge) or level triggered (Level). The field *DescriptorName*._HE is automatically created to refer to this portion of the resource descriptor, where ‘1’ is Edge and ‘0’ is Level.

ActiveLevel describes whether the interrupt is active-high (ActiveHigh) or active-low (ActiveLow). The field *DescriptorName*._LL is automatically created to refer to this portion of the resource descriptor, where ‘1’ is ActiveLow and ‘0’ is ActiveHigh.

Shared describes whether the interrupt can be shared with other devices (Shared) or not (Exclusive), and whether it is capable of waking the system from a low-power idle or system sleep state (SharedAndWake or ExclusiveAndWake). The field *DescriptorName*._SHR is automatically created to refer to this portion of the resource descriptor, where ‘1’ is Shared and ‘0’ is Exclusive. If nothing is specified, then Exclusive is assumed.

ResourceSourceIndex evaluates to an integer between 0x00 and 0xFF and describes the resource source index. If it is not specified, then it is not generated. If this argument is specified, the ResourceSource argument must also be specified.

ResourceSource evaluates to a string which uniquely identifies the resource source. If it is not specified, it is not generated. If this argument is specified, but the *ResourceSourceIndex* argument is not specified, a zero value is assumed.

DescriptorName evaluates to a name string which refers to the entire resource descriptor.

InterruptList is a comma-delimited list on integers, at least one value is required. Each integer represents a 32-bit interrupt number. At least one interrupt must be defined, and there may be no duplicates in the list. The field “DescriptorName. _INT” is automatically created to refer to this portion of the resource descriptor.

Description

The Interrupt macro evaluates to a buffer that contains an interrupt resource descriptor. The format of this descriptor can be found in Section 6.4.3.6. This macro is designed to be used inside of a *ResourceTemplate (Resource To Buffer Conversion Macro)*.

The interrupt macro uses the *ResourceUsage* field to distinguish two types of devices, a *ResourceProducer* and a *ResourceConsumer*.

A **ResourceProducer** represents a device that can forward interrupts from one or more devices to processors under the OSPM. Usage of *ResourceProducer* within interrupt macros is undefined and will be ignored by the OSPM. Declaring interrupt macros as *ResourceProducer* is not recommended.

A **ResourceConsumer** is a device that consumes the interrupts declared in the *InterruptList*. Most devices fall under this category and use this method to declare the interrupts that can be generated by that device. The interrupt descriptors declared as *ResourceConsumer*, are generated by either the main interrupt controller described in the MADT or by a device that acts as an “interrupt producer”. The *ResourceSource* field is used to make this distinction. If this is omitted, the interrupt numbers in the *InterruptList* identify global system interrupts, GSIVs, and these interrupts target the main interrupt controller described in the MADT (see Section 5.2.12). The *ResourceSource* field may also provide the name of a device that is an “interrupt producer”. In this case the interrupt numbers in the *InterruptList* refer to the private interrupt number space of the indicated an interrupt set of the “interrupt producer” device.

The **ResourceSourceIndex** parameter is reserved. If a platform specifies “Interrupt ResourceSource support” in the Platform-Wide _OSC (bit 13 in Table 6.13), the *ResourceSourceIndex* parameter must be zero.

The following example illustrates how to specify consumption of a “secondary interrupt”. In this example, the device SDC0 consumes a secondary interrupt from MUX0, which multiplexes a group of secondary interrupts lines and generates a single summary interrupt (also referred to as an “interrupt producer”). The device driver for MUX0 is expected to generate a specific software based secondary interrupt based on implementation defined details of that device:

```
Scope (\_SB) {
    Device (MUX0) {
        Name (_HID, "ACME0F0F") // vendor specific interrupt combiner
        Name (_UID, 0)
        Name (_CRS, ResourceTemplate () {
            //Register Interface
            MEMORY32FIXED(ReadWrite, 0x30000000, 0x200, )
            //Summary Interrupt line (GSIV 51)
            Interrupt(ResourceConsumer, Level, ActiveHigh, Exclusive) {51}
        })
    }

    Device (SDC0) {
        Name (_HID, EISAID("PNP0D40")) // SDA Standard Compliant SD Host Controller
        Name (_UID, 0)
        Name (_CRS, ResourceTemplate() {
            //Register Interface
```

(continues on next page)

(continued from previous page)

```

MEMORY32FIXED(ReadWrite, 0xFF000000, 0x200, )
// Secondary Interrupt 10 from interrupt combiner MUX0
Interrupt(ResourceConsumer, Edge, ActiveHigh, Exclusive, 0, "\\_SB.MUX0"){10}
}
)
}
}

```

19.6.65 IO (IO Resource Descriptor Macro)

Syntax:

```

IO (Decode , AddressMin, AddressMax, AddressAlignment, RangeLength, DescriptorName) =>
↪ Buffer

```

Argument

Decode describes whether the I/O range uses 10-bit decode (Decode10) or 16-bit decode (Decode16). The field *DescriptorName*.*_DEC* is automatically created to refer to this portion of the resource descriptor, where ‘1’ is Decode16 and ‘0’ is Decode10.

AddressMin evaluates to a 16-bit integer that specifies the minimum acceptable starting address for the I/O range. It must be an even multiple of *AddressAlignment*. The field *DescriptorName*.*_MIN* is automatically created to refer to this portion of the resource descriptor.

AddressMax evaluates to a 16-bit integer that specifies the maximum acceptable starting address for the I/O range. It must be an even multiple of *AddressAlignment*. The field *DescriptorName*.*_MAX* is automatically created to refer to this portion of the resource descriptor.

AddressAlignment evaluates to an 8-bit integer that specifies the alignment granularity for the I/O address assigned. The field *DescriptorName*.*_ALN* is automatically created to refer to this portion of the resource descriptor.

RangeLength evaluates to an 8-bit integer that specifies the number of bytes in the I/O range. The field *DescriptorName*.*_LEN* is automatically created to refer to this portion of the resource descriptor.

DescriptorName is an optional argument that specifies a name for an integer constant that will be created in the current scope that contains the offset of this resource descriptor within the current resource template buffer. The predefined descriptor field names may be appended to this name to access individual fields within the descriptor via the Buffer Field operators.

Description

The IO macro evaluates to a buffer that contains an IO resource descriptor. The format of the IO descriptor can be found in Section 6.4.2.5. This macro is designed to be used inside of a *ResourceTemplate (Resource To Buffer Conversion Macro)*.

19.6.66 IRQ (Interrupt Resource Descriptor Macro)

Syntax:

```
IRQ ( EdgeLevel, ActiveLevel, Shared, DescriptorName ) {InterruptList} => Buffer
```

Arguments

EdgeLevel describes whether the interrupt is edge triggered (Edge) or level triggered (Level). The field *DescriptorName_HE* is automatically created to refer to this portion of the resource descriptor, where ‘1’ is Edge and ‘0’ is Level.

ActiveLevel describes whether the interrupt is active-high (ActiveHigh) or active-low (ActiveLow). The field *DescriptorName_LL* is automatically created to refer to this portion of the resource descriptor, where ‘1’ is ActiveLow and ‘0’ is ActiveHigh.

Shared describes whether the interrupt can be shared with other devices (Shared) or not (Exclusive), and whether it is capable of waking the system from a low-power idle or system sleep state (SharedAndWake or ExclusiveAndWake). The field *DescriptorName_SHR* is automatically created to refer to this portion of the resource descriptor, where ‘1’ is Shared and ‘0’ is Exclusive. If nothing is specified, then Exclusive is assumed.

DescriptorName is an optional argument that specifies a name for an integer constant that will be created in the current scope that contains the offset of this resource descriptor within the current resource template buffer. The predefined descriptor field names may be appended to this name to access individual fields within the descriptor via the Buffer Field operators.

InterruptList is a comma-delimited list of integers in the range 0 through 15, at least one value is required. There may be no duplicates in the list.

Description

The IRQ macro evaluates to a buffer that contains an IRQ resource descriptor. The format of the IRQ descriptor can be found in Section 6.4.2.1. This macro is designed to be used inside of a *ResourceTemplate (Resource To Buffer Conversion Macro)*.

19.6.67 IRQNoFlags (Interrupt Resource Descriptor Macro)

Syntax:

```
IRQNoFlags ( DescriptorName ) { InterruptList } => Buffer
```

Arguments

DescriptorName is an optional argument that specifies a name for an integer constant that will be created in the current scope that contains the offset of this resource descriptor within the current resource template buffer.

InterruptList is a comma-delimited list of integers in the range 0 through 15, at least one value is required. There may be no duplicates in the list

The IRQNoFlags macro evaluates to a buffer that contains an active-high, edge-triggered IRQ resource descriptor. The format of the IRQ descriptor can be found in Section 6.4.2.1. This macro is designed to be used inside of a *ResourceTemplate (Resource To Buffer Conversion Macro)*.

19.6.68 LAnd (Logical And)

Syntax:

```
LAnd ( Source1, Source2 ) => Boolean
```

Source1 && *Source2* => Boolean

Arguments

Source1 and *Source2* are evaluated as integers.

Description

If both values are non-zero, True is returned; otherwise, False is returned.

19.6.69 LEqual (Logical Equal)

Syntax:

```
LEqual (Source1, Source2) => Boolean
```

Source1 == *Source2* => Boolean

Arguments

Source1 and *Source2* must each evaluate to an integer, a string, or a buffer. The data type of *Source1* dictates the required type of *Source2*. *Source2* is implicitly converted if necessary to match the type of *Source1*.

Description

If the values are equal, True is returned; otherwise, False is returned. For integers, a numeric compare is performed. For strings and buffers, True is returned only if both lengths are the same and the result of a byte-wise compare indicates exact equality.

19.6.70 LGreater (Logical Greater)

Syntax:

```
LGreater (Source1, Source2) => Boolean
```

Source1 > *Source2* => Boolean

Arguments

Source1 and *Source2* must each evaluate to an integer, a string, or a buffer. The data type of *Source1* dictates the required type of *Source2*. *Source2* is implicitly converted if necessary to match the type of *Source1*.

Description

If *Source1* is greater than *Source2*, True is returned; otherwise, False is returned. For integers, a numeric comparison is performed. For strings and buffers, a lexicographic comparison is performed. True is returned if a byte-wise (unsigned) compare discovers at least one byte in *Source1* that is numerically greater than the corresponding byte in *Source2*. False is returned if at least one byte in *Source1* is numerically less than the corresponding byte in *Source2*. In the case of byte-wise equality, True is returned if the length of *Source1* is greater than *Source2*, False is returned if the length of *Source1* is less than or equal to *Source2*.

19.6.71 LGreaterEqual (Logical Greater Than Or Equal)

Syntax:

```
LGreaterEqual (Source1, Source2) => Boolean
```

Source1 >= *Source2* => Boolean

Arguments

Source1 and *Source2* must each evaluate to an integer, a string, or a buffer. The data type of *Source1* dictates the required type of *Source2*. *Source2* is implicitly converted if necessary to match the type of *Source1*.

Description

If *Source1* is greater than or equal to *Source2*, True is returned; otherwise, False is returned. Equivalent to LNot(LLess()). See the description of the LLess operator.

19.6.72 LLess (Logical Less)

Syntax:

```
LLess (Source1, Source2) => Boolean  
Source1 < source2 => Boolean
```

Arguments

Source1 and *Source2* must each evaluate to an integer, a string, or a buffer. The data type of *Source1* dictates the required type of *Source2*. *Source2* is implicitly converted if necessary to match the type of *Source1*.

Description

If *Source1* is less than *Source2*, True is returned; otherwise, False is returned. For integers, a numeric comparison is performed. For strings and buffers, a lexicographic comparison is performed. True is returned if a byte-wise (unsigned) compare discovers at least one byte in *Source1* that is numerically less than the corresponding byte in *Source2*. False is returned if at least one byte in *Source1* is numerically greater than the corresponding byte in *Source2*. In the case of byte-wise equality, True is returned if the length of *Source1* is less than *Source2*, False is returned if the length of *Source1* is greater than or equal to *Source2*.

19.6.73 LLessEqual (Logical Less Than Or Equal)

Syntax:

```
LLessEqual (Source1, Source2) => Boolean  
Source1 <= source2 => Boolean
```

Arguments

Source1 and *Source2* must each evaluate to an integer, a string, or a buffer. The data type of *Source1* dictates the required type of *Source2*. *Source2* is implicitly converted if necessary to match the type of *Source1*.

Description

If *Source1* is less than or equal to *Source2*, True is returned; otherwise False is returned. Equivalent to LNot(LGreater()). See the description of the LGreater operator.

19.6.74 LNot (Logical Not)

Syntax:

```
LNot (Source) => Boolean
```

! *Source* => Boolean

Arguments

Source is evaluated as an integer.

Description

If the value is zero True is returned; otherwise, False is returned.

19.6.75 LNotEqual (Logical Not Equal)

Syntax:

```
LNotEqual ( Source1, Source2 ) => Boolean  
Source1 != Source2 => Boolean
```

Arguments

Source1 and Source2 must each evaluate to an integer, a string, or a buffer. The data type of Source1 dictates the required type of Source2. Source2 is implicitly converted if necessary to match the type of Source1.

Description

If Source1 is not equal to Source2, True is returned; otherwise False is returned. Equivalent to LNot(LEqual()). See the description of the LEqual operator.

19.6.76 Load (Load Definition Block)

Syntax:

```
Load (Object, Result) => Boolean
```

Arguments

The Object parameter can refer to one of the following object types:

1. An operation region field
2. An operation region directly
3. An ASL Buffer object

If the object is an operation region, the operation region must be in SystemMemory space. The Definition Block should contain an ACPI DESCRIPTION_HEADER of type SSDT. The Definition Block must be totally contained within the supplied operation region, operation region field, or Buffer object. OSPM reads this table into memory, the checksum is verified, and then it is loaded into the ACPI namespace.

Result is optional and is a Boolean indicating the status of the operation. A value of zero (false) means the operation failed. Any other value means that the operation was successful. Also, this value is always returned as the function return value

Description

Performs a run-time load of a Definition Block. Any table loaded via an operation region must be in memory marked as AddressRangeReserved or AddressRangeNVS. The OS can also check the OEM Table ID and Revision ID against a database for a newer revision Definition Block of the same OEM Table ID and load it instead.

The default namespace location to load the Definition Block is relative to the root of the namespace. The new Definition Block can override this by specifying absolute names or by adjusting the namespace location using the Scope operator.

Loading a Definition Block is a synchronous operation. Upon completion of the operation, the Definition Block has been loaded. The control methods defined in the Definition Block are not executed during load time.

19.6.77 LoadTable (Load Definition Block From XSDT)

Syntax:

```
LoadTable ( SignatureString, OEMIDString, OEMTableIDString,
RootPathString, ParameterPathString, ParameterData ) => Boolean
```

Arguments

The XSDT is searched for a table where the Signature field matches SignatureString, the OEM ID field matches OEMIDString, and the OEM Table ID matches OEMTableIDString. All comparisons are case sensitive. If the SignatureString is greater than four characters, the OEMIDString is greater than six characters, or the OEMTableID is greater than eight characters, a run-time error is generated. The OS can also check the OEM Table ID and Revision ID against a database for a newer revision Definition Block of the same OEM Table ID and load it instead.

The RootPathString specifies the root of the Definition Block. It is evaluated using normal scoping rules, assuming that the scope of the LoadTable instruction is the current scope. The new Definition Block can override this by specifying absolute names or by adjusting the namespace location using the Scope operator. If RootPathString is not specified, "" is assumed

If ParameterPathString and ParameterData are specified, the data object specified by ParameterData is stored into the object specified by ParameterPathString after the table has been added into the namespace. If the first character of ParameterPathString is a backslash ('\') or caret (^) character, then the path of the object is ParameterPathString. Otherwise, it is RootPathString.ParameterPathString. If the specified object does not exist, a run-time error is generated.

The status of the operation is returned as a Boolean. A value of zero (false) means the operation failed. Any other value means that the operation was successful.

Description

Performs a run-time load of a Definition Block from the XSDT. Any table referenced by LoadTable must be in memory marked by AddressRangeReserved or AddressRangeNVS.

Note: OSPM loads the DSDT and all SSDTs during initialization. As such, Definition Blocks to be conditionally loaded via LoadTable must contain signatures other than "SSDT".

Loading a Definition Block is a synchronous operation. Upon completion of the operation, the Definition Block has been loaded. The control methods defined in the Definition Block are not executed during load time.

Example:

```
Store (LoadTable ("OEM1", "MYOEM", "TABLE1", "\\_SB.PCI0", "MYD", Package () {0, "\\_SB.
↳PCI0"}), Local0)
```

This operation would search through the RSDT or XSDT for a table with the signature "OEM1," the OEM ID of "MYOEM," and the table ID of "TABLE1." If not found, it would store Zero in Local0. Otherwise, it will store a package containing 0 and "_SB.PCI0" into the variable at _SB.PCI0.MYD.

19.6.78 Localx (Method Local Data Objects)

Syntax:

```
Local0 | Local1 | Local2 | Local3 | Local4 | Local5 | Local6 | Local7
```

Description

Up to 8 local objects can be referenced in a control method. On entry to a control method, these objects are uninitialized and cannot be used until some value or reference is stored into the object. Once initialized, these objects are preserved in the scope of execution for that control method.

19.6.79 LOr (Logical Or)

Syntax:

```
LOr ( Source1, Source2 ) => Boolean
Source1 || Source2 => Boolean
```

Arguments

Source1 and *Source2* are evaluated as integers.

Description

If either value is non-zero, True is returned; otherwise, False is returned.

19.6.80 Match (Find Object Match)

Syntax:

```
Match ( SearchPackage, Op1, MatchObject1, Op2, MatchObject2, StartIndex ) => Ones \ | _
↪ Integer
```

Arguments

SearchPackage is evaluated to a package object and is treated as a one-dimension array. Each package element must evaluate to either an integer, a string, or a buffer. Uninitialized package elements and elements that do not evaluate to integers, strings, or buffers are ignored. *Op1* and *Op2* are match operators. *MatchObject1* and *MatchObject2* are the objects to be matched and must each evaluate to either an integer, a string, or a buffer. *StartIndex* is the starting index within the *SearchPackage*.

Description

A comparison is performed for each element of the package, starting with the index value indicated by *StartIndex* (0 is the first element). If the element of *SearchPackage* being compared against is called *P[i]*, then the comparison is:

```
If (P[i] Op1 MatchObject1) and (P[i] Op2 MatchObject2) then Match => i is returned.
```

If the comparison succeeds, the index of the element that succeeded is returned; otherwise, the constant object *Ones* is returned. The data type of the *MatchObject* dictates the required type of the package element. If necessary, the package element is implicitly converted to match the type of the *MatchObject*. If the implicit conversion fails for any reason, the package element is ignored (no match.)

Op1 and *Op2* have the values and meanings listed in the following table.

Table 19.35: Match Term Operator Meanings

Operator	Encoding	Macro
TRUE - A don't care, always returns TRUE	0	MTR
EQ - Returns TRUE if P[i] == MatchObject	1	MEQ
LE - Returns TRUE if P[i] <= MatchObject	2	MLE
LT - Returns TRUE if P[i] < MatchObject	3	MLT
GE - Returns TRUE if P[i] >= MatchObject	4	MGE
GT - Returns TRUE if P[i] > MatchObject	5	MGT

Example

Following are some example uses of Match:

```
Name (P1,
Package () {1981, 1983, 1985, 1987, 1989, 1990, 1991, 1993, 1995, 1997, 1999, 2001}
)

// match 1993 == P1[i]
Match (P1, MEQ, 1993, MTR, 0, 0) // -> 7, since P1[7] == 1993

// match 1984 == P1[i]
Match (P1, MEQ, 1984, MTR, 0, 0) // -> ONES (not found)

// match P1[i] > 1984 and P1[i] <= 2000
Match (P1, MGT, 1984, MLE, 2000, 0) // -> 2, since P1[2]>1984 and P1[2]<=2000

// match P1[i] > 1984 and P1[i] <= 2000, starting with 3rd element
Match (P1, MGT, 1984, MLE, 2000, 3) // -> 3, first match at or past Start
```

19.6.81 Memory24 (Memory Resource Descriptor Macro)

Syntax:

```
Memory24 (ReadAndWrite, AddressMinimum, AddressMaximum, AddressAlignment, RangeLength, ↵
↵DescriptorName)
```

Arguments

ReadAndWrite specifies whether or not the memory region is read-only (ReadOnly) or read/write (ReadWrite). If nothing is specified, then ReadWrite is assumed. The 1-bit field DescriptorName._RW is automatically created to refer to this portion of the resource descriptor, where '1' is ReadWrite and '0' is ReadOnly.

AddressMinimum evaluates to a 16-bit integer that specifies bits [8:23] of the lowest possible base address of the memory range. All other bits are assumed to be zero. The value must be an even multiple of AddressAlignment. The 16-bit field DescriptorName._MIN is automatically created to refer to this portion of the resource descriptor.

AddressMaximum evaluates to a 16-bit integer that specifies bits [8:23] of the highest possible base address of the memory range. All other bits are assumed to be zero. The value must be an even multiple of AddressAlignment. The 16-bit field DescriptorName._MAX is automatically created to refer to this portion of the resource descriptor.

AddressAlignment evaluates to a 16-bit integer that specifies bits [0:15] of the required alignment for the memory range. All other bits are assumed to be zero. The address selected must be an even multiple of this value. The 16-bit field DescriptorName._ALN is automatically created to refer to this portion of the resource descriptor.

RangeLength evaluates to a 16-bit integer that specifies the total number of bytes decoded in the memory range. The 16-bit field DescriptorName._LEN is automatically created to refer to this portion of the resource descriptor. The range length provides the length of the memory range in 256 byte blocks.

DescriptorName is an optional argument that specifies a name for an integer constant that will be created in the current scope that contains the offset of this resource descriptor within the current resource template buffer. The predefined descriptor field names may be appended to this name to access individual fields within the descriptor via the Buffer Field operators.

Description

The `Memory24` macro evaluates to a buffer that contains an 24-bit memory descriptor. The format of this descriptor can be found in [Table 6.40](#). This macro is designed to be used inside of a *ResourceTemplate (Resource To Buffer Conversion Macro)*.

Note: The use of `Memory24` is deprecated and should not be used in new designs*.

19.6.82 Memory32 (Memory Resource Descriptor Macro)

Syntax:

```
Memory32 (ReadAndWrite, AddressMinimum, AddressMaximum, AddressAlignment, RangeLength,
↪ DescriptorName)
```

Arguments

ReadAndWrite specifies whether or not the memory region is read-only (ReadOnly) or read/write (ReadWrite). If nothing is specified, then ReadWrite is assumed. The 1-bit field `DescriptorName._RW` is automatically created to refer to this portion of the resource descriptor, where '1' is ReadWrite and '0' is ReadOnly.

AddressMinimum evaluates to a 32-bit integer that specifies the lowest possible base address of the memory range. The value must be an even multiple of `AddressAlignment`. The 32-bit field `DescriptorName._MIN` is automatically created to refer to this portion of the resource descriptor.

AddressMaximum evaluates to a 32-bit integer that specifies the highest possible base address of the memory range. The value must be an even multiple of `AddressAlignment`. The 32-bit field `DescriptorName._MAX` is automatically created to refer to this portion of the resource descriptor.

AddressAlignment evaluates to a 32-bit integer that specifies the required alignment for the memory range. The address selected must be an even multiple of this value. The 32-bit field `DescriptorName._ALN` is automatically created to refer to this portion of the resource descriptor.

RangeLength evaluates to a 32-bit integer that specifies the total number of bytes decoded in the memory range. The 32-bit field `DescriptorName._LEN` is automatically created to refer to this portion of the resource descriptor. The range length provides the length of the memory range in 1 byte blocks.

DescriptorName is an optional argument that specifies a name for an integer constant that will be created in the current scope that contains the offset of this resource descriptor within the current resource template buffer. The predefined descriptor field names may be appended to this name to access individual fields within the descriptor via the Buffer Field operators.

Description

The `Memory32` macro evaluates to a buffer that contains a 32-bit memory descriptor, which describes a memory range with a minimum, a maximum and an alignment. The format of this descriptor can be found in [Section 6.4.3.3](#). This macro is designed to be used inside of a *ResourceTemplate (Resource To Buffer Conversion Macro)*.

19.6.83 Memory32Fixed (Memory Resource Descriptor Macro)

Syntax:

```
Memory32Fixed (ReadAndWrite, AddressBase, RangeLength, DescriptorName)
```

Arguments

ReadAndWrite specifies whether or not the memory region is read-only (ReadOnly) or read/write (ReadWrite). If nothing is specified, then ReadWrite is assumed. The 1-bit field DescriptorName._RW is automatically created to refer to this portion of the resource descriptor, where '1' is ReadWrite and '0' is ReadOnly.

AddressBase evaluates to a 32-bit integer that specifies the base address of the memory range. The 32-bit field DescriptorName._BAS is automatically created to refer to this portion of the resource descriptor.

RangeLength evaluates to a 32-bit integer that specifies the total number of bytes decoded in the memory range. The 32-bit field DescriptorName._LEN is automatically created to refer to this portion of the resource descriptor.

DescriptorName is an optional argument that specifies a name for an integer constant that will be created in the current scope that contains the offset of this resource descriptor within the current resource template buffer. The predefined descriptor field names may be appended to this name to access individual fields within the descriptor via the Buffer Field operators.

Description

The Memory32Fixed macro evaluates to a buffer that contains a 32-bit memory descriptor, which describes a fixed range of memory addresses. The format of this memory descriptor can be found in Section 6.4.3.4. This macro is designed to be used inside of a *ResourceTemplate (Resource To Buffer Conversion Macro)*.

19.6.84 Method (Declare Control Method)

Syntax:

```
Method ( MethodName, NumArgs, SerializeRule, SyncLevel, ReturnType, ParameterTypes )
↪ {TermList}
```

Arguments

MethodName is evaluated as a Namestring data type.

NumArgs is optional and is the required number of arguments to be passed to the method, evaluated as an Integer data type. If not specified, the default value is zero arguments. Up to 7 arguments may be passed to a method. These arguments may be referenced from within the method as Arg0 through Arg6.

SerializeRule is optional and is a flag that defines whether the method is serialized or not and is one of the following: Serialized or NotSerialized. A method that is serialized cannot be reentered by additional threads. If not specified, the default is NotSerialized.

SyncLevel is optional and specifies the synchronization level for the method (0 - 15). If not specified, the default sync level is zero.

ReturnType is optional and specifies the type(s) of the object(s) returned by the method. If the method does not return an object, then nothing is specified or UnknownObj is specified. To specify a single return type, simply use the ObjectTypeKeyword (e.g. IntObj, PkgObj, etc.). To specify multiple possible return types, enclose the comma-separated ObjectTypeKeywords with braces. For example: {IntObj, BuffObj}.

ParameterTypes is optional and specifies the type of the method parameters. It is a comma-separated, variable-length list of the expected object type or types for each of the method parameters, enclosed in braces. For each parameter, the parameter type consists of either an ObjectTypeKeyword or a comma-separated sub-list of ObjectTypeKeywords enclosed in braces. If ParameterTypes is specified, the number of parameters must match NumArgs.

TermList is a variable-length list of executable ASL statements representing the body of the control method.

Description

Creates a new control method of name *MethodName*. This is a named package containing a series of object references that collectively represent a control method, which is a procedure that can be invoked to perform computation. Method opens a name scope.

System software executes a control method by referencing the objects in the package in order. For more information on method execution, see [Section 5.5.2](#)

The current namespace location used during name creation is adjusted to be the current location on the namespace tree. Any names created within this scope are “below” the name of this package. The current namespace location is assigned to the method package, and all namespace references that occur during control method execution for this package are relative to that location.

If a method is declared as *Serialized*, an implicit mutex associated with the method object is acquired at the specified *SyncLevel*. If no *SyncLevel* is specified, *SyncLevel 0* is assumed. The *serialize* rule can be used to prevent reentering of a method. This is especially useful if the method creates namespace objects. Without the *serialize* rule, the reentering of a method will fail when it attempts to create the same namespace object.

There are eight local variables automatically available for each method, referenced as *Local0* through *Local7*. These locals may be used to store any type of ASL object.

Also notice that all namespace objects created by a method have temporary lifetime. When method execution exits, the created objects will be destroyed.

Examples

The following block of ASL sample code shows a use of *Method* for defining a control method that turns on a power resource.

```
Method (_ON) {
    Store (One, GPIO.IDEP) // assert power
    Sleep (10) // wait 10ms
    Store (One, GPIO.IDER) // de-assert reset#
    Stall (10) // wait 10us
    Store (Zero, GPIO.IDEI) // de-assert isolation
}
```

This method is an implementation of *_SRS* (Set Resources). It shows the use of a method argument and two method locals:

```
Method (_SRS, 1, NotSerialized)
{
    CreateWordField (Arg0, One, IRQW)
    Store (\_SB.PCI0.PID1.IENA, Local1)
    Or (IRQW, Local1, Local1)
    Store (Local1, \_SB.PCI0.PID1.IENA)
    FindSetRightBit (IRQW, Local0)
    If (Local0)
    {
        Decrement (Local0)
        Store (Local0, \_SB.PCI0.PID1.IN01)
    }
}
```

19.6.85 Mid (Extract Portion of Buffer or String)

Syntax:

```
Mid ( Source, Index, Length, Result ) => Buffer or String
```

Arguments

Source is evaluated as either a Buffer or String. *Index* and *Length* are evaluated as Integers.

Description

If *Source* is a buffer, then *Length* bytes, starting with the *Index*th byte (zero-based) are optionally copied into *Result*. If *Index* is greater than or equal to the length of the buffer, then the result is an empty buffer. Otherwise, if *Index* + *Length* is greater than or equal to the length of the buffer, then only bytes up to and including the last byte are included in the result.

If *Source* is a string, then *Length* characters, starting with the *Index*th character (zero-based) are optionally copied into *Result*. If *Index* is greater than or equal to the length of the buffer, then the result is an empty string. Otherwise, if *Index* + *Length* is greater than or equal to the length of the string, then only bytes up to an including the last character are included in the result.

19.6.86 Mod (Integer Modulo)

Syntax:

```
Mod ( Dividend, Divisor, Result ) => Integer
Result = Dividend % Divisor => Integer
Result %= Divisor => Integer
```

Arguments

Dividend and *Divisor* are evaluated as Integers.

Description

The *Dividend* is divided by *Divisor*, and then the resulting remainder is optionally stored into *Result*. If *Divisor* evaluates to zero, a fatal exception is generated.

19.6.87 Multiply (Integer Multiply)

Syntax:

```
Multiply ( Multiplicand, Multiplier, Result ) => Integer
Result = Multiplicand \ Multiplier => Integer
Result \= Multiplier => Integer
```

Arguments

Multiplicand and *Multiplier* are evaluated as Integers.

Description

The *Multiplicand* is multiplied by *Multiplier* and the result is optionally stored into *Result*. Overflow conditions are ignored and results are undefined.

19.6.88 Mutex (Declare Synchronization/Mutex Object)

Syntax:

```
Mutex ( MutexName, SyncLevel )
```

Arguments

The `MutexName` is evaluated as a Namestring data type.

The `SyncLevel` is optional and specifies the logical nesting level of the Mutex synchronization object. The current sync level is maintained internally for a thread, and represents the greatest `SyncLevel` among mutex objects that are currently acquired by the thread. The `SyncLevel` of a thread, before acquiring any mutexes, is zero. The `SyncLevel` of the Global Lock (`_GL`) is zero. If not specified, the default sync level value is zero.

Description

Creates a data mutex synchronization object named `MutexName`, with a synchronization level from 0 to 15 as specified by the Integer `SyncLevel`.

A mutex synchronization object provides a control method with a mechanism for waiting for certain events. To prevent deadlocks, wherever more than one synchronization object must be owned, the synchronization objects must always be released in the order opposite the order in which they were acquired.

The `SyncLevel` parameter declares the logical nesting level of the synchronization object. The current sync level is maintained internally for a thread, and represents the greatest `SyncLevel` among mutex objects that are currently acquired by the thread. The `SyncLevel` of a thread before acquiring any mutexes is zero. The `SyncLevel` of the Global Lock (`_GL`) is zero.

All Acquire terms must refer to a synchronization object with a `SyncLevel` that is equal or greater than the current level, and all Release terms must refer to a synchronization object with a `SyncLevel` that is equal to the current level.

Mutex synchronization provides the means for mutually exclusive ownership. Ownership is acquired using an Acquire term and is released using a Release term. Ownership of a Mutex must be relinquished before completion of any invocation. For example, the top-level control method cannot exit while still holding ownership of a Mutex. Acquiring ownership of a Mutex can be nested (can be acquired multiple times by the same thread).

19.6.89 Name (Declare Named Object)

Syntax:

```
Name ( ObjectName, Object )
```

Arguments

Creates a new object named `ObjectName`. Attaches `Object` to `ObjectName` in the Global ACPI namespace.

Description

Creates `ObjectName` in the namespace, which references the `Object`.

Example

The following example creates the name `PTTX` in the root of the namespace that references a package.

```
Name (\PTTX,                                     // Port to Port Translate Table
      Package () {Package () {0x43, 0x59}, Package () {0x90, 0xFF}}
)
```

The following example creates the name `CNT` in the root of the namespace that references an integer data object with the value 5:

```
Name (\CNT, 5)
```

19.6.90 NAnd (Integer Bitwise Nand)

Syntax:

```
NAnd (Source1, Source2, Result) => Integer
```

Arguments

Source1 and *Source2* are evaluated as Integers.

Description

A bitwise NAND is performed and the result is optionally stored in *Result*.

19.6.91 NoOp Code (No Operation)

Syntax:

```
NoOp
```

Description

This operation has no effect.

19.6.92 NOR (Integer Bitwise Nor)

Syntax:

```
NOR (Source1, Source2, Result) => Integer
```

Arguments

Source1 and *Source2* are evaluated as Integers.

Description

A bitwise NOR is performed and the result is optionally stored in *Result*.

19.6.93 Not (Integer Bitwise Not)

Syntax:

```
Not (Source, Result) => Integer
```

Result = \sim *Source* => Integer

Arguments

Source is evaluated as an integer data type.

Description

A bitwise NOT is performed and the result is optionally stored in *Result*.

19.6.94 Notify (Notify Object of Event)

Syntax:

```
Notify (Object, NotificationValue)
```

Arguments

Notifies the OS that the NotificationValue for the Object has occurred. Object must be a reference to a device, processor, or thermal zone object.

Description

Object type determines the notification values. For example, the notification values for a thermal zone object are different from the notification values used for a device object. Undefined notification values are treated as reserved and are ignored by the OS.

For lists of defined Notification values, see [Section 5.6.6](#)

19.6.95 Offset (Change Current Field Unit Offset)

Syntax:

```
Offset (ByteOffset)
```

Arguments

ByteOffset is the new offset (in bytes) for the next FieldUnit within a FieldList.

Description

The Offset operator is used within a FieldList to specify the byteOffset of the next defined field within its parent operation region. This can be used instead of defining the bit lengths that need to be skipped. All offsets are defined starting from zero, based at the starting address of the parent region.

19.6.96 ObjectType (Get Object Type)

Syntax:

```
ObjectType (Object) => Integer
```

Arguments

Object is any valid object.

Description

The execution result of this operation is an integer that has the numeric value of the object type for Object.

The object type codes are listed in the following table. Note that if this operation is performed on an object reference such as one produced by the Alias, Index, or RefOf statements, the object type of the base object is returned. For typeless objects such as predefined scope names (in other words, _SB, _GPE, etc.), the type value 0 (Uninitialized) is returned.

Table 19.36: Values Returned By the ObjectType Operator

Value	Object
0	Uninitialized

continues on next page

Table 19.36 – continued from previous page

Value	Object
1	Integer
2	String
3	Buffer
4	Package
5	Field Unit
6	Device
7	Event
8	Method
9	Mutex
10	Operation Region
11	Power Resource
12	<i>Reserved</i>
13	Thermal Zone
14	Buffer Field
15	<i>Reserved</i>
16	Debug Object
>16	<i>Reserved</i>

19.6.97 One (Constant One Integer)

Syntax:

```
One => Integer
```

Description

The One operator returns an Integer with the value 1. Writes to this object are not allowed. The use of this operator can reduce AML code size, since it is represented by a one-byte AML opcode.

19.6.98 Ones (Constant Ones Integer)

Syntax:

```
Ones => Integer
```

Description

The Ones operator returns an Integer with all bits set to 1. Writes to this object are not allowed. The use of this operator can reduce AML code size, since it is represented by a one-byte AML opcode.

Note: The actual value of the integer returned by the Ones operator depends on the integer width of the DSDT. If the revision of the DSDT is 1 or less, the integer width is 32 bits and Ones returns 0xFFFFFFFF. If the revision of the DSDT is 2 or greater, the integer width is 64 bits and Ones returns 0xFFFFFFFFFFFFFFFF. This difference must be considered when performing comparisons against the Ones Integer.

19.6.99 OperationRegion (Declare Operation Region)

Syntax:

```
OperationRegion (RegionName, RegionSpace, Offset, Length)
```

Arguments

Declares an operation region named `RegionName`. `Offset` is the offset within the selected `RegionSpace` at which the region starts (byte-granular), and `Length` is the length of the region in bytes.

Description

An Operation Region is a type of data object where read or write operations to the data object are performed in some hardware space. For example, the Definition Block can define an Operation Region within a bus, or system I/O space. Any reads or writes to the named object will result in accesses to the I/O space.

Operation regions are regions in some space that contain hardware registers for exclusive use by ACPI control methods. In general, no hardware register (at least byte-granular) within the operation region accessed by an ACPI control method can be shared with any accesses from any other source, with the exception of using the Global Lock to share a region with the firmware. The entire Operation Region can be allocated for exclusive use to the ACPI subsystem in the host OS.

Operation Regions that are defined within the scope of a method are the exception to this rule. These Operation Regions are known as “Dynamic” since the OS has no idea that they exist or what registers they use until the control method is executed. Using a Dynamic SystemIO or SystemMemory Operation Region is not recommended since the OS cannot guarantee exclusive access. All other types of Operation Regions may be Dynamic.

Operation Regions define the overall base address and length of a hardware region, but they cannot be accessed directly by AML code. A Field object containing one or more FieldUnits is used to overlay the Operation Region in order to access individual areas of the Region. An individual FieldUnit within an Operation Region may be as small as one bit, or as large as the length of the entire Region. FieldUnit values are normalized (shifted and masked to the proper length.) The data type of a FieldUnit can be either a Buffer or an Integer, depending on the bit length of the FieldUnit. If the FieldUnit is smaller than or equal to the size of an Integer (in bits), it will be treated as an Integer. If the FieldUnit is larger than the size of an Integer, it will be treated as a Buffer. The size of an Integer is indicated by the DSDT header’s Revision field. A revision less than 2 indicates that the size of an Integer is 32 bits. A value greater than or equal to 2 signifies that the size of an Integer is 64 bits. For more information about data types and FieldUnit type conversion rules, see [Section 19.3.5.7](#).

An Operation Region object implicitly supports Mutex synchronization. Updates to the object, or a Field data object for the region, will automatically synchronize on the Operation Region object; however, a control method may also explicitly synchronize to a region to prevent other accesses to the region (from other control methods). Notice that according to the control method execution model, control method execution is non-preemptive. Because of this, explicit synchronization to an Operation Region needs to be done only in cases where a control method blocks or yields execution and where the type of register usage requires such synchronization.

The predefined Operation Region types specified in ACPI are shown in [Table 5.182](#)

Example

The following example ASL code shows the use of OperationRegion combined with Field to describe IDE 0 and 1 controlled through general I/O space, using one FET:

```
OperationRegion (GIO, SystemIO, 0x125, 0x1)
Field (GIO, ByteAcc, NoLock, Preserve) {
    IDEI, 1,           // IDEISO_EN - isolation buffer
    IDEP, 1,           // IDE_PWR_EN - power
    IDER, 1            // IDERST#_EN - reset#
}
```

19.6.100 Or (Integer Bitwise Or)

Syntax:

```
Or (Source1, Source2, Result) => Integer
*Result* = *Source1* \| *Source2* => Integer
*Result* \|= *Source1* => Integer
```

Arguments

Source1 and *Source2* are evaluated as Integers.

Description

A bitwise OR is performed and the result is optionally stored in *Result*.

19.6.101 Package (Declare Package Object)

Syntax:

```
Package (NumElements) {PackageList} => Package
```

Arguments

NumElements is evaluated as an Integer. *PackageList* is an initializer list of objects.

Description

Declares an unnamed aggregation of named data items, constants, and/or references to non-data namespace objects. The size of the package is *NumElements*. The *PackageList* contains the data items, constants, and/or object references used to initialize the package.

If *NumElements* is absent, it is automatically set by the ASL compiler to match the number of elements in the *PackageList*. If *NumElements* is present and greater than the number of elements in the *PackageList*, the default entry of type Uninitialized (see *ObjectType*) is used to initialize the package elements beyond those initialized from the *PackageList*.

There are three types of package elements allowed in the *PackageList*: ConstantData Objects (Integers, Strings, Buffers, and Packages), named references that resolve to Data Objects (Integers, Strings, Buffers, and Packages), and named references to objects other than Data Objects.

These constant terms are resolved at ASL compile time:

- Integer Constant
- String Constant
- Buffer Constant
- Package Constant

These Named References to Data Objects are resolved to actual data by the AML Interpreter at runtime:

- Integer reference
- String reference
- Buffer reference
- Buffer Field reference
- Field Unit reference
- Package reference

These Named References to non-Data Objects cannot be resolved to values. They are instead returned in the package as references:

- Device reference
- Event reference
- Method reference
- Mutex reference
- Operation Region reference
- Power Resource reference
- Processor reference
- Thermal Zone reference

Note: For Package elements of type Package (defining a subpackage), individual elements of the subpackage are resolved according to the rules above, both compile-time and runtime.*

Evaluating an uninitialized element will yield a runtime error, but elements can be assigned values at runtime to define them (via the Index operator). It is a compile time error for *NumElements* to be less than the number of elements defined in the *PackageList*.

The ASL compiler can emit two different AML opcodes for a Package declaration, either *PackageOp* or *VarPackageOp*. For small, fixed-length packages, the *PackageOp* is used and this opcode is compatible with ACPI 1.0. A *VarPackageOp* will be emitted if any of the following conditions are true:

- The *NumElements* argument is a TermArg that can only be resolved at runtime.
- At compile time, *NumElements* resolves to a constant that is larger than 255.
- The *PackageList* contains more than 255 initializer elements.

Example:

```
Name (INT1, 0x1234)
Processor (CPU0, 0, 0x1010, 6) {}
PowerResource (PWR1, 0, 0) {}

Name (PKG1, Package () {
    0x3400,           // Integer Constant, resolved at compile time
    "Processor "     // String Constant, resolved at compile time
    \INT1            // Integer Reference, resolved to value at
                    // runtime
    \CPU0            // Object Reference, returned as a reference
                    // object
    Package () {    // Package Constant. Elements are resolved at
                    // both compile time and runtime
        0x4321,     // Integer Constant, resolved at compile time
        \INT1,     // Integer Reference, resolved to value at
                    // runtime
        \PWR1
    })
})
```

The runtime values of the parent package and subpackages are:

```

Package [Contains 0x05 Elements] {
  (00) Integer 0x00000000000003400
  (01) String [0x09] "Processor"
  (02) Integer 0x00000000000001234
  (03) Reference [Named Object] [CPU0] Processor
  (04) Package [Contains 0x03 Elements]
    (00) Integer 0x00000000000004321
    (01) Integer 0x00000000000001234
    (02) Reference [Named Object] [PWR1] Power
}

```

19.6.102 PinConfig (Pin Configuration Descriptor Macro)

Syntax:

```

Macro:

PinConfig (Shared/Exclusive, PinConfigType, PinConfigValue, ResourceSource,
ResourceSourceIndex, ResourceUsage, DescriptorName, VendorData) {Pin List}

```

Arguments

- *Shared* is an optional argument and can be either Shared or Exclusive. If not specified, Exclusive is assumed. The bit field name `_SHR` is automatically created to refer to this portion of the resource descriptor.
- *PinConfigType* can be one of the configuration types described below in *Pin Configuration Types and Values* . The bit field `_TYP` is automatically created to refer to this portion of the resource descriptor.
- *PinConfigValue* is one of the configurations values described below in *Pin Configuration Types and Values* . The bit field `_VAL` is automatically created to refer to this portion of the resource descriptor.
- *ResourceSource* is a string which uniquely identifies the pin controller referred to by this descriptor. ResourceSource can be a fully-qualified name, a relative name or a name segment that utilizes the namespace search rules.
- *ResourceSourceIndex* is an optional argument and is assumed to be 0 for this revision.
- *ResourceUsage* is an optional argument and is assumed to be ResourceConsumer for this revision.
- *DescriptorName* is an optional argument that specifies a name for an integer constant that will be created in the current scope that contains the offset of this resource descriptor within the current resource template buffer. The predefined descriptor field names may be appended to this name to access individual fields within the descriptor via the Buffer Field operators.
- *VendorData* is an optional argument that specifies a RawDataBuffer containing vendor-defined byte data to be decoded by the OS driver. The bit field name `_VEN` is automatically created to refer to this portion of the resource descriptor.
- *PinList* is a list of pin numbers on the ResourceSource that are described by this descriptor. The bit field name `_PIN` is automatically created to refer to this portion of the resource descriptor.

Table 19.37: Pin Configuration Types and Values

Pin Type	Configuration	Pin Value	Configuration	Description
0x00 = Default		N/A		Default configuration. No configuration is applied.

continues on next page

Table 19.37 – continued from previous page

Pin Type	Configuration	Pin Value	Configuration	Description
0x01 = Bias Pull-Up		Pull up resistance, in Ohms.		This means the pin is pulled up with a certain number of Ohms to an implicitly supplied VDD rail.
0x02 = Bias Pull-down		Pull down resistance, in Ohms.		This means the pin is pulled down with a certain number of Ohms, toward the GND rail.
0x03 = Bias Default		N/A		If the silicon has a default biasing mode, reset the pin to this mode.
0x04 = Bias Disable		N/A		Any software-selectable bias settings on the pin will be disabled.
0x05 = Bias High Impedance		N/A		This means that the pin is configured into a high impedance mode and essentially shut off from the outside world. It will not influence the signal state if a rail is connected to the pin, hence a good default mode.
0x06 = Bias Bus Hold		N/A		This will make the pin in a weak latch state where it weakly drives the last value on a tristate bus.
0x07 = Drive Open Drain		N/A		This will configure the pin into open drain (open collector) state.
0x08 = Drive Open Source		N/A		This will configure the pin into open source (open emitter) state.
0x09 = Drive Push Pull		N/A		This will configure the pin into explicit push-pull state. This is useful if the power-on default state is e.g. open drain or high impedance state.
0x0A = Drive Strength		Drive strength in milliamperes		This will set the output driver of the pin to supply a certain number of milliamperes, usually by activating several driver stages.
0x0B = Slew Rate		Custom format		This controls the slew rate of the pin, affecting speed but also sharpness of edges and thus noisiness on the board. The hardware-specific argument tells what slew rate to configure
0x0C = Input Debounce		Debounce time in microseconds.		This will enable debouncing (for e.g. key inputs) of the pin signal.
0x0D = Input Schmitt Trigger		Enabled = 1, Disabled = 0		This will enable Schmitt trigger support for the line.
0x0E - 0x7F = Reserved		Reserved		Reserved
0x80 - 0xFF = Vendor defined values		Custom base		From this point, vendor and Hardware-specific configurations are listed.

Description

The PinConfig macro evaluates to a buffer that contains a Pin Configuration resource descriptor, as described in [Section 6.4.3.10](#). This macro is designed to be used inside of a *ResourceTemplate (Resource To Buffer Conversion Macro)*.

Note: There is some overlap between the properties set by GpioIo/GpioInt/ PinFunction and PinConfig descriptors. For example, both are setting properties such as pull-ups. If the same property is specified by multiple descriptors for the same pins, the order in which these properties are applied is undetermined. To avoid any conflicts, GpioInt/GpioIo/PinFunction should provide a default value for these properties when PinConfig is used. If PinConfig is used to set pin bias, PullDefault should be used for GpioIo/GpioInt/ PinFunction. If PinConfig is used to set debounce timeout, 0 should be used for GpioIo/GpioInt. If PinConfig is used to set drive strength, 0 should be used for GpioIo.*

Example:

```
//
```

(continues on next page)

(continued from previous page)

```

// Description: GPIO
//
Device (GPIO)
{
    Name (_HID, "PNPFFFE")
    Name (_UID, 0x0)
    Method (_STA)
    {
        Return(0xf)
    }
    Method (_CRS, 0x0, NotSerialized)
    {
        Name (RBUF, ResourceTemplate()
        {
            Memory32Fixed(ReadWrite, 0x4FE00000, 0x20)
            Interrupt(ResourceConsumer, Level, ActiveHigh, Shared) {0x54}
        })
        Return(RBUF)
    }
}

//
// Description: I2C controller 1
//
Device (I2C1)
{
    Name (_HID, "PNPFFFF")
    Name (_UID, 0x0)
    Method (_STA)
    {
        Return(0xf)
    }
    Method (_CRS, 0x0, NotSerialized)
    {
        Name (RBUF, ResourceTemplate()
        {
            Memory32Fixed(ReadWrite, 0x4F800000, 0x20)
            Interrupt(ResourceConsumer, Level, ActiveHigh, Shared) {0x55}
            PinFunction(Exclusive, PullDefault, 0x5, "\\_SB.GPIO", 0, ResourceConsumer,
→ {2, 3}
            // Configure 10k Pull up for I2C SDA/SCL pins
            PinConfig(Exclusive, 0x01, 10000, "\\_SB.GPIO", 0, ResourceConsumer, ) {2, 3}
        })
        Return(RBUF)
    }
}

//
// Description: Physical display panel
//
Device (SDIO)
{
    Name (_HID, "PNPFFFD")
    Name (_UID, 0x0)
    Method (_STA)
    {
        Return(0xf)
    }
}

```

(continues on next page)

(continued from previous page)

```

}
Method (_CRS, 0x0, NotSerialized)
{
    Name (RBUF, ResourceTemplate()
    {
        Memory32Fixed(ReadWrite, 0x4F900000, 0x20)
        Interrupt(ResourceConsumer, Level, ActiveHigh, Shared) {0x57}
        GpioIo(Shared, PullDefault, 0, 0, IoRestrictionNone, "\\_SB.GPIO",) {2, 3}
        // Configure 20k Pull down
        PinConfig(Exclusive, 0x02, 20000, "\\_SB.GPIO", 0, ResourceConsumer, ) {2, 3}
        // Enable Schmitt-trigger
        PinConfig(Exclusive, 0x0D, 1, "\\_SB.GPIO", 0, ResourceConsumer, ) {2, 3}
        // Set slew rate to custom value 3
        PinConfig(Exclusive, 0x0B, 3, "\\_SB.GPIO", 0, ResourceConsumer, ) {2, 3}
    })
    Return(RBUF)
}
}

```

19.6.103 PinFunction (Pin Function Descriptor Macro)

Syntax:

```

Macro:

PinFunction (Shared/Exclusive, PinPullConfiguration, FunctionNumber, ResourceSource,
ResourceSourceIndex, ResourceUsage, DescriptorName, VendorData) {Pin List}

```

Arguments

- *Shared* is an optional argument and can be one of Shared, Exclusive. If not specified, Exclusive is assumed. The bit field name *_SHR* is automatically created to refer to this portion of the resource descriptor.
- *PinPullConfiguration* can be one of PullDefault, PullUp, PullDown, PullNone or a vendor-supplied value in the range 128-255.
- *FunctionNumber* is a provider-specific integer that designates which function is being described.
- *ResourceSource* is a string which uniquely identifies the GPIO controller referred to by this descriptor. *ResourceSource* can be a fully-qualified name, a relative name or a name segment that utilizes the namespace search rules.
- *ResourceSourceIndex* is an optional argument and is assumed to be 0 for this revision.
- *ResourceUsage* is an optional argument and is assumed to be ResourceConsumer for this revision.
- *DescriptorName* is an optional argument that specifies a name for an integer constant that will be created in the current scope that contains the offset of this resource descriptor within the current resource template buffer. The predefined descriptor field names may be appended to this name to access individual fields within the descriptor via the Buffer Field operators.
- *VendorData* is an optional argument that specifies a RawDataBuffer containing vendor-defined byte data to be decoded by the OS driver. The bit field name *_VEN* is automatically created to refer to this portion of the resource descriptor.
- *PinList* is a non-empty list of (zero-based) pin numbers on the ResourceSource that are described by this descriptor. The bit field name *_PIN* is automatically created to refer to this portion of the resource descriptor.

Description

The PinFunction macro evaluates to a buffer that contains a Pin Function resource descriptor, as described in this section. This macro is designed to be used inside of a *ResourceTemplate (Resource To Buffer Conversion Macro)*.

Note: PinFunction macro allows for maximum flexibility to define the desired function of each pin individually. It is the responsibility of the firmware writer to take into account any platform-level restrictions where pin function must be applied at a coarser granularity. Thus, if the platform design requires the functions for a set of pins to be configured as group, the firmware writer must ensure this is done in the corresponding PinFunction description by specifying all relevant pins in a single PinFunction. In the multi-pin scenario, the OSPM must honor the PinFunction requirements for all of the specified pins on an “all-or-nothing” basis.

Note: The Pin Function descriptor is intended for scenarios where non-GPIO functions are desired. For GPIO-based functionalities, the firmware should always specify the appropriate GpioIo or GpioInt descriptor.

Example:

```
//
// Description: GPIO
//

Device (GPIO)
{
    Name (_HID, "PNPFFFF")
    Name (_UID, 0x0)
    Method (_STA)
    {
        Return(0xf)
    }
    Method (_CRS, 0x0, NotSerialized)
    {
        Name (RBUF, ResourceTemplate()
        {
            Memory32Fixed(ReadWrite, 0x4FE00000, 0x20)
            Interrupt(ResourceConsumer, Level, ActiveHigh, Shared) {0x54}
        })
        Return(RBUF)
    }
}

//
// Description: I2C controller 1
//

Device (I2C1)
{
    Name (_HID, "PNPFFFF")
    Name (_UID, 0x0)
    Method (_STA)
    {
        Return(0xf)
    }
    Method (_CRS, 0x0, NotSerialized)
    {
        Name (RBUF, ResourceTemplate()
        {
            Memory32Fixed(ReadWrite, 0x4F800000, 0x20)
            Interrupt(ResourceConsumer, Level, ActiveHigh, Shared) {0x55}
            PinFunction(Exclusive, PullUp, 0x5, "\\_SB.GPIO", 0, ResourceConsumer,) {2, ↵
↵3}

```

(continues on next page)

(continued from previous page)

```

    })
    Return(RBUF)
  }
}

//
// Description: I2C controller 2
//

Device (I2C2)
{
  Name (_HID, "PNPFFFF")
  Name (_UID, 0x1)
  Method (_STA)
  {
    Return(0xf)
  }
  Method (_CRS, 0x0, NotSerialized)
  {
    Name (RBUF, ResourceTemplate()
    {
      Memory32Fixed(ReadWrite, 0x4F900000, 0x20)
      Interrupt(ResourceConsumer, Level, ActiveHigh, Shared) {0x56}
      PinFunction(Exclusive, PullUp, 0x0, 0x4, "\\_SB.GPIO", 0, ResourceConsumer,
→) {2, 3}
    })
    Return(RBUF)
  }
}

//
// Description: Physical display panel
//

Device (DISP)
{
  Name (_HID, "PNPFFFD")
  Name (_UID, 0x0)
  Method (_STA)
  {
    Return(0xf)
  }
  Method (_CRS, 0x0, NotSerialized)
  {
    Name (RBUF, ResourceTemplate()
    {
      Memory32Fixed(ReadWrite, 0x4F900000, 0x20)
      Interrupt(ResourceConsumer, Level, ActiveHigh, Shared) {0x57}
      GpioIo(Shared, PullDefault, 0, 0, IoRestrictionNone, "\\_SB.GPIO",) {2, 3}
    })
    Return(RBUF)
  }
}
}

```

19.6.104 PinGroup (Pin Group Descriptor Macro)

Syntax:

```
Macro:
PinGroup (ResourceLabel, ResourceUsage, DescriptorName, VendorData) {Pin List }
```

Arguments

- *ResourceUsage* is an optional argument and is assumed to be ResourceProducer for this revision.
- *ResourceLabel* is an arbitrary, non-empty string that uniquely identifies this particular PinGroup resource from others within a resource template buffer. This label is used by resource consumers to refer to this resource.
- *DescriptorName* is an optional argument that specifies a name for an integer constant that will be created in the current scope that contains the offset of this resource descriptor within the current resource template buffer. The predefined descriptor field names may be appended to this name to access individual fields within the descriptor via the Buffer Field operators.
- *VendorData* is an optional argument that specifies a RawDataBuffer containing vendor-defined byte data to be decoded by the OS driver. The bit field name `_VEN` is automatically created to refer to this portion of the resource descriptor.
- *PinList* is a non-empty list of (zero-based) pin numbers on the ResourceSource that are described by this descriptor. The bit field name `_PIN` is automatically created to refer to this portion of the resource descriptor.

Description

The PinGroup macro evaluates to a buffer that contains a Pin Group Configuration resource descriptor. The format of the Pin Group Configuration resource descriptor can be found in [Section 6.4.3.13](#). This macro is designed to be used inside of a *ResourceTemplate (Resource To Buffer Conversion Macro)*.

PinGroup resource descriptors must be declared within the scope of the pin controller device to which the pins belong.

19.6.105 PinGroupConfig (Pin Group Configuration Descriptor Macro)

Syntax:

```
Macro:
PinGroupConfig (Shared/Exclusive, PinConfigType, PinConfigValue, ResourceSource,
ResourceSourceIndex, ResourceSourceLabel, ResourceUsage, DescriptorName, VendorData)
```

Arguments:

- *Shared* is an optional argument and can be either Shared or Exclusive. If not specified, Exclusive is assumed. The bit field name `_SHR` is automatically created to refer to this portion of the resource descriptor.
- *PinConfigType* can be one of the configuration types described below in *Pin Group Configuration Types and Values*. The bit field name `_TYP` is automatically created to refer to this portion of the resource descriptor.
- *PinConfigValue* is one of the configurations values described below in *Pin Group Configuration Types and Values*. The bit field name `_VAL` is automatically created to refer to this portion of the resource descriptor.
- *ResourceSource* is a string that uniquely identifies the GPIO controller which includes the PinGroup resource referenced by this descriptor. ResourceSource can be a fully-qualified name, a relative name or a name segment that utilizes the namespace search rules.
- *ResourceSourceLabel* is a non-empty string argument that matches ResourceLabel of the PinGroup resource in the current resource template buffer of the GPIO controller referenced in ResourceSource.

- *DescriptorName* is an optional argument that specifies a name for an integer constant that will be created in the current scope that contains the offset of this resource descriptor within the current resource template buffer. The predefined descriptor field names may be appended to this name to access individual fields within the descriptor via the Buffer Field operators.
- *ResourceSourceIndex* is an optional argument and is assumed to be 0 for this revision.
- *ResourceUsage* is an optional argument and is assumed to be ResourceConsumer for this revision.
- *VendorData* is an optional argument that specifies a RawDataBuffer containing vendor-defined byte data to be decoded by the OS driver. The bit field name `_VEN` is automatically created to refer to this portion of the resource descriptor.

Table 19.38: Pin Group Configuration Types and Values

Pin Configuration Type	Pin Configuration Value	Description
0x00 = Default	N/A	Default configuration. No configuration is applied).
0x01 = Bias Pull-Up	Pull up resistance, in Ohms.	This means the pin is pulled up with a certain number of Ohms to an implicitly supplied VDD rail.
0x02 = Bias Pull-down	Pull down resistance, in Ohms.	This means the pin is pulled down with a certain number of Ohms, toward the GND rail.
0x03 = Bias Default	N/A	If the silicon has a default biasing mode, reset the pin to this mode.
0x04 = Bias Disable	N/A	Any software-selectable bias settings on the pin will be disabled.
0x05 = Bias High Impedance	N/A	This means that the pin is configured into a high impedance mode and essentially shut off from the outside world. It will not influence the signal state if a rail is connected to the pin, hence a good default mode.
0x06 = Bias Bus Hold	N/A	This will make the pin in a weak latch state where it weakly drives the last value on a tristate bus.
0x07 = Drive Open Drain	N/A	This will configure the pin into open drain (open collector) state.
0x08 = Drive Open Source	N/A	This will configure the pin into open source (open emitter) state.
0x09 = Drive Push Pull	N/A	This will configure the pin into explicit push-pull state. This is useful if the power-on default state is e.g. open drain or high impedance state.
0x0A = Drive Strength	Drive strength in milliamperes	This will set the output driver of the pin to supply a certain number of milliamperes, usually by activating several driver stages.
0x0B = Slew Rate	Custom format	This controls the slew rate of the pin, affecting speed but also sharpness of edges and thus noisiness on the board. The hardware-specific argument tells what slew rate to configure
0x0C = Input Debounce	Debounce time in microseconds.	This will enable debouncing (for e.g. key inputs) of the pin signal.
0x0D = Input Schmitt Trigger	Enabled = 1, Disabled = 0	This will enable Schmitt trigger support for the line.
0x0E - 0x7F = Reserved	Reserved	Reserved
0x80 - 0xFF = Vendor defined values	Custom base	From this point, vendor and Hardware-specific configurations are listed.

Description

The `PinGroupConfig` macro evaluates to a buffer that contains a Pin Group Configuration resource descriptor. The format of the Pin Group Configuration resource descriptor can be found in [Section 6.4.3.13](#). This macro is designed to be used inside of a *ResourceTemplate* (*Resource To Buffer Conversion Macro*).

Example:

```
//
// Description: GPIO
//

Device (GPIO)
{
    Name (_HID, "PNPFFFE")
    Name (_UID, 0x0)
    Method (_STA)
    {
        Return(0xf)
    }
    Method (_CRS, 0x0, NotSerialized)
    {
        Name (RBUF, ResourceTemplate()
        {
            Memory32Fixed(ReadWrite, 0x4FE00000, 0x20)
            Interrupt(ResourceConsumer, Level, ActiveHigh, Shared) {0x54}
            PinGroup("group1", ResourceProducer) {2, 3}
        })
        Return(RBUF)
    }
}

//
// Description: I2C controller 1
//

Device (I2C1)
{
    Name (_HID, "PNPFFFF")
    Name (_UID, 0x0)
    Method (_STA)
    {
        Return(0xf)
    }
    Method (_CRS, 0x0, NotSerialized)
    {
        Name (RBUF, ResourceTemplate()
        {
            Memory32Fixed(ReadWrite, 0x4F800000, 0x20)
            Interrupt(ResourceConsumer, Level, ActiveHigh, Shared) {0x55}
            // Set function I2C1 for SDA/SCL pins
            PinGroupFunction(Exclusive, 0x5, "\\_SB.GPIO, 0, "group1", ResourceConsumer,
↪)
            // Configure 10k Pull up for SDA/SCL pins
            PinGroupConfig(Exclusive, 0x01, 10000, "\\_SB.GPIO ", 0, "group1",
↪ResourceConsumer, )
        })
        Return(RBUF)
    }
}
}
```

(continues on next page)

(continued from previous page)

```

//
// Description: I2C controller 2
//

Device (I2C2)
{
    Name (_HID, "PNPFFFF")
    Name (_UID, 0x1)
    Method (_STA)
    {
        Return(0xf)
    }
    Method (_CRS, 0x0, NotSerialized)
    {
        Name (RBUF, ResourceTemplate()
        {
            Memory32Fixed(ReadWrite, 0x4F900000, 0x20)
            Interrupt(ResourceConsumer, Level, ActiveHigh, Shared) {0x56}
            // Set function I2C2 for SDA/SCL pins
            PinGroupFunction(Exclusive, 0x4, "\\_SB.GPIO ", 0, "group1",
↪ResourceConsumer, )
            // Configure 10k Pull up for SDA/SCL pins
            PinGroupConfig(Exclusive, 0x01, 10000, "\\_SB.GPIO ", 0, "group1",
↪ResourceConsumer, )
        })
        Return(RBUF)
    }
}

//
// Description: Physical display panel
//

Device (DISP)
{
    Name (_HID, "PNPFFFD")
    Name (_UID, 0x0)
    Method (_STA)
    {
        Return(0xf)
    }
    Method (_CRS, 0x0, NotSerialized)
    {
        Name (RBUF, ResourceTemplate()
        {
            Memory32Fixed(ReadWrite, 0x4F900000, 0x20)
            Interrupt(ResourceConsumer, Level, ActiveHigh, Shared) {0x57}
            // Set function GPIO for pin group group1
            PinGroupFunction(Exclusive, 0x1, "\\_SB.GPIO ", 0, "group1",
↪ResourceConsumer, )
            // Configure 20k Pull down
            PinGroupConfig (Exclusive, 0x02, 20000, "\\_SB.GPIO ", 0, "group1",
↪ResourceConsumer, )
            //Enable Schmitt-trigger
            PinGroupConfig (Exclusive, 0x0D, 1, "\\_SB.GPIO ", 0, "group1",
↪ResourceConsumer, )
            //Set slew rate to custom value 3

```

(continues on next page)

(continued from previous page)

```

        PinGroupConfig (Exclusive, 0x0B, 3, "\\_SB.GPIO ", 0, "group1",
↪ResourceConsumer, )
        ))
        Return(RBUF) }
    }
}

```

19.6.106 PinGroupFunction (Pin Group Function Configuration Descriptor Macro)

Syntax:

Macro:

```

PinGroupFunction (Shared/Exclusive, FunctionNumber, ResourceSource,
↪ResourceSourceIndex,
ResourceSourceLabel, ResourceUsage, DescriptorName, VendorData)

```

Arguments

- *Shared* is an optional argument and can be one of Shared, Exclusive. If not specified, Exclusive is assumed. The bit field name `_SHR` is automatically created to refer to this portion of the resource descriptor.
- *FunctionNumber* is a provider-specific integer which designates which function is being described. The bit field name `_FUN` is automatically created to refer to this portion of the resource descriptor.
- *ResourceSource* is a string that uniquely identifies the GPIO controller which includes the PinGroup resource referenced by this descriptor. ResourceSource can be a fully-qualified name, a relative name or a name segment that utilizes the namespace search rules.
- *ResourceSourceLabel* is a non-empty string argument that matches ResourceLabel of a PinGroup resource in the current resource template buffer of the GPIO controller referenced in ResourceSource.
- DescriptorName is an optional argument that specifies a name for an integer constant that will be created in the current scope that contains the offset of this resource descriptor within the current resource template buffer. The predefined descriptor field names may be appended to this name to access individual fields within the descriptor via the Buffer Field operators.
- *ResourceSourceIndex* is an optional argument and is assumed to be 0 for this revision.
- ResourceUsage is an optional argument and is assumed to be ResourceConsumer for this revision.
- *VendorData* is an optional argument that specifies a RawDataBuffer containing vendor-defined byte data to be decoded by the OS driver. The bit field name `_VEN` is automatically created to refer to this portion of the resource descriptor.

Description

The PinGroupFunction macro evaluates to a buffer that contains a Pin Function resource descriptor. The format of the Pin Function resource descriptor can be found in *Pin Function Descriptor*. This macro is designed to be used inside of a *ResourceTemplate (Resource To Buffer Conversion Macro)*.

19.6.107 PowerResource (Declare Power Resource)

Syntax:

```
PowerResource (ResourceName, SystemLevel, ResourceOrder) {TermList}
```

Arguments

Declares a power resource named *ResourceName*. *PowerResource* opens a name scope.

Description

For a definition of the *PowerResource* term, see [Section 7.2](#)

The power management object list is encoded as *TermList*, so that rather than describing a static power management object list, it is possible to describe a dynamic power management object list according to the system settings. See “*Definition Block Loading*”:

19.6.108 Printf (Create and Store formatted string)

Syntax:

```
Printf (FormatString, FormatArgs) => String
```

Arguments

Printf is a macro that converts the evaluated *FormatString* into a series of string *Concatenate* operations, storing the result in the Debug object.

FormatString is a string literal which may contain one or more uses of the format specifier, *%o*, to indicate locations in the string where an object may be inserted. *%o* is the only format specifier supported since the resulting object is a string and type conversion is handled automatically by *Concatenate*.

FormatArgs is a comma separated list of Named Objects, Locals, or Args that can be evaluated to a string. Each argument is added to the *FormatString* using the *Concatenate* operation at the location specified by *%o* in order of appearance.

Description

The *Printf* macro converts a format string into a series of cascading string *Concatenate* operations, and stores the result in the Debug object

Example

The following ASL example uses *Printf* to write a formatted string with the values of *Arg0*, *Arg1*, *Arg2*, and *Arg3* to the Debug Object:

```
Printf ("%o: Unexpected value for %o, %o at line %o", Arg0, Arg1, Arg2, Arg3)
```

This *Printf* macro expression evaluates to the following ASL operation:

```
Store (Concatenate (Concatenate (Concatenate (Concatenate
    (Concatenate (Concatenate (Concatenate ("", Arg0),
        ": Unexpected value for "), Arg1), ", "), Arg2),
        " at line "), Arg3), Debug)
```

19.6.109 QWordIO (QWord IO Resource Descriptor Macro)

Syntax:

```
QWordIO ( ResourceUsage, IsMinFixed, IsMaxFixed, Decode, ISARanges, 
↳AddressGranularity, AddressMinimum, AddressMaximum,
AddressTranslation, RangeLength, ResourceSourceIndex, ResourceSource, DescriptorName, 
↳TranslationType, TranslationDensity)
```

Arguments

ResourceUsage specifies whether the I/O range is consumed by this device (ResourceConsumer) or passed on to child devices (ResourceProducer). If nothing is specified, then ResourceConsumer is assumed.

IsMinFixed specifies whether the minimum address of this I/O range is fixed (MinFixed) or can be changed (MinNotFixed). If nothing is specified, then MinNotFixed is assumed. The 1-bit field DescriptorName. *_MIF* is automatically created to refer to this portion of the resource descriptor, where '1' is MinFixed and '0' is MinNotFixed.

IsMaxFixed specifies whether the maximum address of this I/O range is fixed (MaxFixed) or can be changed (MaxNotFixed). If nothing is specified, then MaxNotFixed is assumed. The 1-bit field DescriptorName. *_MAF* is automatically created to refer to this portion of the resource descriptor, where '1' is MaxFixed and '0' is MaxNotFixed.

Decode specifies whether or not the device decodes the I/O range using positive (PosDecode) or subtractive (SubDecode) decode. If nothing is specified, then PosDecode is assumed. The 1-bit field DescriptorName. *_DEC* is automatically created to refer to this portion of the resource descriptor, where '1' is SubDecode and '0' is PosDecode.

ISARanges specifies whether the I/O ranges specifies are limited to valid ISA I/O ranges (ISAOnly), valid non-ISA I/O ranges (NonISAOnly) or encompass the whole range without limitation (EntireRange). The 2-bit field DescriptorName. *_RNG* is automatically created to refer to this portion of the resource descriptor, where '1' is NonISAOnly, '2' is ISAOnly and '0' is EntireRange.

AddressGranularity evaluates to a 64-bit integer that specifies the power-of-two boundary (- 1) on which the I/O range must be aligned. The 64-bit field DescriptorName. *_GRA* is automatically created to refer to this portion of the resource descriptor.

AddressMinimum evaluates to a 64-bit integer that specifies the lowest possible base address of the I/O range. The value must have '0' in all bits where the corresponding bit in AddressGranularity is '1'. For bridge devices which translate addresses, this is the address on the secondary bus. The 64-bit field DescriptorName. *_MIN* is automatically created to refer to this portion of the resource descriptor.

AddressMaximum evaluates to a 64-bit integer that specifies the highest possible base address of the I/O range. The value must have '0' in all bits where the corresponding bit in AddressGranularity is '1'. For bridge devices which translate addresses, this is the address on the secondary bus. The 64-bit field DescriptorName. *_MAX* is automatically created to refer to this portion of the resource descriptor.

AddressTranslation evaluates to a 64-bit integer that specifies the offset to be added to a secondary bus I/O address which results in the corresponding primary bus I/O address. For all non-bridge devices or bridges which do not perform translation, this must be '0'. The 64-bit field DescriptorName. *_TRA* is automatically created to refer to this portion of the resource descriptor.

RangeLength evaluates to a 64-bit integer that specifies the total number of bytes decoded in the I/O range. The 64-bit field DescriptorName. *_LEN* is automatically created to refer to this portion of the resource descriptor.

ResourceSourceIndex is an optional argument which evaluates to an 8-bit integer that specifies the resource descriptor within the object specified by ResourceSource. If this argument is specified, the ResourceSource argument must also be specified.

ResourceSource is an optional argument which evaluates to a string containing the path of a device which produces the pool of resources from which this I/O range is allocated. If this argument is specified, but the ResourceSourceIndex argument is not specified, a zero value is assumed.

DescriptorName is an optional argument that specifies a name for an integer constant that will be created in the current scope that contains the offset of this resource descriptor within the current resource template buffer. The predefined descriptor field names may be appended to this name to access individual fields within the descriptor via the Buffer Field operators.

TranslationType is an optional argument that specifies whether the resource type on the secondary side of the bus is different (TypeTranslation) from that on the primary side of the bus or the same (TypeStatic). If TypeTranslation is specified, then the primary side of the bus is Memory. If TypeStatic is specified, then the primary side of the bus is I/O. If nothing is specified, then TypeStatic is assumed. The 1-bit field DescriptorName. *_TTP* is automatically created to refer to this portion of the resource descriptor, where ‘1’ is TypeTranslation and ‘0’ is TypeStatic. See *_TTP* for more information

TranslationDensity is an optional argument that specifies whether or not the translation from the primary to secondary bus is sparse (SparseTranslation) or dense (DenseTranslation). It is only used when TranslationType is TypeTranslation. If nothing is specified, then DenseTranslation is assumed. The 1-bit field DescriptorName. *_TRS* is automatically created to refer to this portion of the resource descriptor, where ‘1’ is SparseTranslation and ‘0’ is DenseTranslation. See *_TRS* for more information.

Description

The QWordIO macro evaluates to a buffer that contains a 64-bit I/O resource descriptor, which describes a range of I/O addresses. The format of the 64-bit I/O resource descriptor can be found in Section 6.4.3.5.1. This macro is designed to be used inside of a *ResourceTemplate (Resource To Buffer Conversion Macro)*.

19.6.110 QWordMemory (QWord Memory Resource Descriptor Macro)

Syntax:

```
QWordMemory (ResourceUsage, Decode, IsMinFixed, IsMaxFixed, Cacheable, ReadAndWrite, ↵
↵AddressGranularity, AddressMinimum,
AddressMaximum, AddressTranslation, RangeLength, ResourceSourceIndex, ResourceSource, ↵
↵DescriptorName, MemoryRangeType, TranslationType)
```

Arguments

ResourceUsage specifies whether the Memory range is consumed by this device (ResourceConsumer) or passed on to child devices (ResourceProducer). If nothing is specified, then ResourceConsumer is assumed.

Decode specifies whether or not the device decodes the Memory range using positive (PosDecode) or subtractive (SubDecode) decode. If nothing is specified, then PosDecode is assumed. The 1-bit field DescriptorName. *_DEC* is automatically created to refer to this portion of the resource descriptor, where ‘1’ is SubDecode and ‘0’ is PosDecode.

IsMinFixed specifies whether the minimum address of this Memory range is fixed (MinFixed) or can be changed (MinNotFixed). If nothing is specified, then MinNotFixed is assumed. The 1-bit field DescriptorName. *_MIF* is automatically created to refer to this portion of the resource descriptor, where ‘1’ is MinFixed and ‘0’ is MinNotFixed.

IsMaxFixed specifies whether the maximum address of this Memory range is fixed (MaxFixed) or can be changed (MaxNotFixed). If nothing is specified, then MaxNotFixed is assumed. The 1-bit field DescriptorName. *_MAF* is automatically created to refer to this portion of the resource descriptor, where ‘1’ is MaxFixed and ‘0’ is MaxNotFixed.

Cacheable specifies whether or not the memory region is cacheable (Cacheable), cacheable and write-combining (WriteCombining), cacheable and prefetchable (Prefetchable) or uncacheable (NonCacheable). If nothing is specified, then NonCacheable is assumed. The 2-bit field DescriptorName. *_MEM* is automatically created to refer to this portion of the resource descriptor, where ‘1’ is Cacheable, ‘2’ is WriteCombining, ‘3’ is Prefetchable and ‘0’ is NonCacheable.

ReadAndWrite specifies whether or not the memory region is read-only (ReadOnly) or read/write (ReadWrite). If nothing is specified, then ReadWrite is assumed. The 1-bit field DescriptorName. *_RW* is automatically created to refer to this portion of the resource descriptor, where ‘1’ is ReadWrite and ‘0’ is ReadOnly.

AddressGranularity evaluates to a 64-bit integer that specifies the power-of-two boundary (-1) on which the Memory range must be aligned. The 64-bit field `DescriptorName._GRA` is automatically created to refer to this portion of the resource descriptor.

AddressMinimum evaluates to a 64-bit integer that specifies the lowest possible base address of the Memory range. The value must have '0' in all bits where the corresponding bit in *AddressGranularity* is '1'. For bridge devices which translate addresses, this is the address on the secondary bus. The 64-bit field `DescriptorName._MIN` is automatically created to refer to this portion of the resource descriptor.

AddressMaximum evaluates to a 64-bit integer that specifies the highest possible base address of the Memory range. The value must have '0' in all bits where the corresponding bit in *AddressGranularity* is '1'. For bridge devices which translate addresses, this is the address on the secondary bus. The 64-bit field `DescriptorName._MAX` is automatically created to refer to this portion of the resource descriptor.

AddressTranslation evaluates to a 64-bit integer that specifies the offset to be added to a secondary bus I/O address which results in the corresponding primary bus I/O address. For all non-bridge devices or bridges which do not perform translation, this must be '0'. The 64-bit field `DescriptorName._TRA` is automatically created to refer to this portion of the resource descriptor.

RangeLength evaluates to a 64-bit integer that specifies the total number of bytes decoded in the Memory range. The 64-bit field `DescriptorName._LEN` is automatically created to refer to this portion of the resource descriptor.

ResourceSourceIndex is an optional argument which evaluates to an 8-bit integer that specifies the resource descriptor within the object specified by *ResourceSource*. If this argument is specified, the *ResourceSource* argument must also be specified.

ResourceSource is an optional argument which evaluates to a string containing the path of a device which produces the pool of resources from which this Memory range is allocated. If this argument is specified, but the *ResourceSourceIndex* argument is not specified, a zero value is assumed.

DescriptorName is an optional argument that specifies a name for an integer constant that will be created in the current scope that contains the offset of this resource descriptor within the current resource template buffer. The predefined descriptor field names may be appended to this name to access individual fields within the descriptor via the Buffer Field operators.

MemoryRangeType is an optional argument that specifies the memory usage. The memory can be marked as normal (*AddressRangeMemory*), used as ACPI NVS space (*AddressRangeNVS*), used as ACPI reclaimable space (*AddressRangeACPI*) or as system reserved (*AddressRangeReserved*). If nothing is specified, then *AddressRangeMemory* is assumed. The 2-bit field `DescriptorName._MTP` is automatically created in order to refer to this portion of the resource descriptor, where '0' is *AddressRangeMemory*, '1' is *AddressRangeReserved*, '2' is *AddressRangeACPI* and '3' is *AddressRangeNVS*.

TranslationType is an optional argument that specifies whether the resource type on the secondary side of the bus is different (*TypeTranslation*) from that on the primary side of the bus or the same (*TypeStatic*). If *TypeTranslation* is specified, then the primary side of the bus is I/O. If *TypeStatic* is specified, then the primary side of the bus is Memory. If nothing is specified, then *TypeStatic* is assumed. The 1-bit field `DescriptorName._TTP` is automatically created to refer to this portion of the resource descriptor, where '1' is *TypeTranslation* and '0' is *TypeStatic*. See *_TTP* for more information.

Description

The `QWordMemory` macro evaluates to a buffer that contains a 64-bit memory resource descriptor, which describes a range of memory addresses. The format of the 64-bit memory resource descriptor can be found in [Table 6.45](#). This macro is designed to be used inside of a *ResourceTemplate (Resource To Buffer Conversion Macro)*.

19.6.111 QWordSpace (QWord Space Resource Descriptor Macro)

Syntax:

```
QWordSpace (ResourceType, ResourceUsage, Decode, IsMinFixed, IsMaxFixed, ↵
↵TypeSpecificFlags, AddressGranularity, AddressMinimum,
AddressMaximum, AddressTranslation, RangeLength, ResourceSourceIndex, ResourceSource, ↵
↵DescriptorName) *
```

Arguments

ResourceType evaluates to an 8-bit integer that specifies the type of this resource. Acceptable values are 0xC0 through 0xFF.

ResourceUsage specifies whether the Memory range is consumed by this device (ResourceConsumer) or passed on to child devices (ResourceProducer). If nothing is specified, then ResourceConsumer is assumed.

Decode specifies whether or not the device decodes the Memory range using positive (PosDecode) or subtractive (SubDecode) decode. If nothing is specified, then PosDecode is assumed. The 1-bit field DescriptorName. _DEC is automatically created to refer to this portion of the resource descriptor, where '1' is SubDecode and '0' is PosDecode.

IsMinFixed specifies whether the minimum address of this Memory range is fixed (MinFixed) or can be changed (MinNotFixed). If nothing is specified, then MinNotFixed is assumed. The 1-bit field DescriptorName. _MIF is automatically created to refer to this portion of the resource descriptor, where '1' is MinFixed and '0' is MinNotFixed.

IsMaxFixed specifies whether the maximum address of this Memory range is fixed (MaxFixed) or can be changed (MaxNotFixed). If nothing is specified, then MaxNotFixed is assumed. The 1-bit field DescriptorName. _MAF is automatically created to refer to this portion of the resource descriptor, where '1' is MaxFixed and '0' is MaxNotFixed.

TypeSpecificFlags evaluates to an 8-bit integer. The flags are specific to the ResourceType.

AddressGranularity evaluates to a 64-bit integer that specifies the power-of-two boundary (- 1) on which the Memory range must be aligned. The 64-bit field DescriptorName. _GRA is automatically created to refer to this portion of the resource descriptor.

AddressMinimum evaluates to a 64-bit integer that specifies the lowest possible base address of the Memory range. The value must have '0' in all bits where the corresponding bit in AddressGranularity is '1'. For bridge devices which translate addresses, this is the address on the secondary bus. The 64-bit field DescriptorName. _MIN is automatically created to refer to this portion of the resource descriptor.

AddressMaximum evaluates to a 64-bit integer that specifies the highest possible base address of the Memory range. The value must have '0' in all bits where the corresponding bit in AddressGranularity is '1'. For bridge devices which translate addresses, this is the address on the secondary bus. The 64-bit field DescriptorName. _MAX is automatically created to refer to this portion of the resource descriptor.

AddressTranslation evaluates to a 64-bit integer that specifies the offset to be added to a secondary bus I/O address which results in the corresponding primary bus I/O address. For all non-bridge devices or bridges which do not perform translation, this must be '0'. The 64-bit field DescriptorName. _TRA is automatically created to refer to this portion of the resource descriptor.

RangeLength evaluates to a 64-bit integer that specifies the total number of bytes decoded in the Memory range. The 64-bit field DescriptorName. _LEN is automatically created to refer to this portion of the resource descriptor.

ResourceSourceIndex is an optional argument which evaluates to an 8-bit integer that specifies the resource descriptor within the object specified by ResourceSource. If this argument is specified, the ResourceSource argument must also be specified.

ResourceSource is an optional argument which evaluates to a string containing the path of a device which produces the pool of resources from which this Memory range is allocated. If this argument is specified, but the ResourceSourceIndex argument is not specified, a zero value is assumed.

DescriptorName is an optional argument that specifies a name for an integer constant that will be created in the current scope that contains the offset of this resource descriptor within the current resource template buffer. The predefined descriptor field names may be appended to this name to access individual fields within the descriptor via the Buffer Field operators.

Description

The `QWordSpace` macro evaluates to a buffer which contains a 64-bit Address Space resource descriptor, which describes a range of addresses. The format of the 64-bit AddressSpace descriptor can be found in [Table 6.45](#). This macro is designed to be used inside of a *ResourceTemplate (Resource To Buffer Conversion Macro)*.

19.6.112 RawDataBuffer (Raw Data Buffer)

Syntax:

```
RawDataBuffer (RDBufferSize) {ByteList} => RawDataBuffer
```

Arguments

Declares a `RawDataBuffer` of size `RDBufferSize` and optional initial value of `ByteList`.

Description

The optional `RDBufferSize` parameter specifies the size of the buffer and must be a word constant. The initial value is specified in `Initializer ByteList`. If `RDBufferSize` is not specified, it defaults to the size of initializer. If the count is too small to hold the value specified by initializer, the initializer size is used.

Note that a `RawDataBuffer` is not encoded as a Buffer (Opcode, Package length bytes, etc), but rather contains only the raw bytes specified.

19.6.113 RefOf (Create Object Reference)

Syntax:

```
RefOf (Object) => ObjectReference
```

Arguments

`Object` can be any object type (for example, a package, a device object, and so on).

Description

Returns an object reference to `Object`. If the `Object` does not exist, the result of a `RefOf` operation is fatal. Use the `CondRefOf` term in cases where the `Object` might not exist.

The primary purpose of `RefOf()` is to allow an object to be passed to a method as an argument to the method without the object being evaluated at the time the method was loaded.

19.6.114 Register (Generic Register Resource Descriptor Macro)

Syntax:

```
Register (AddressSpaceKeyword, RegisterBitWidth, RegisterBitOffset, RegisterAddress, ↵
↵AccessSize, DescriptorName)
```

Arguments

AddressSpaceKeyword specifies the address space where the register exists. The register can be one of the following:

- I/O space (SystemIO)
- System Memory (SystemMemory)
- PCI configuration space (PCI_Config)
- Embedded controller space (EmbeddedControl)
- SMBus (SMBus)
- CMOS (SystemCMOS)
- PCI Bar target (PciBarTarget)
- IPMI (IPMI)
- General purpose I/O (GeneralPurposeIO)
- Generic serial bus (GenericSerialBus)
- Platform Communications Channel (PCC)
- Fixed-feature hardware (FFixedHW)

The 8-bit field *DescriptorName*. *_ASI* is automatically created in order to refer to this portion of the resource descriptor. See the Address Space ID definition in *Table: Generic Register Descriptor Definition* for more information, including a list of valid values and their meanings.

RegisterBitWidth evaluates to an 8-bit integer that specifies the number of bits in the register. The 8-bit field *DescriptorName*. *_RBW* is automatically created in order to refer to this portion of the resource descriptor. See the *_RBW* definition in *Table: Generic Register Descriptor Definition* for more information.

RegisterBitOffset evaluates to an 8-bit integer that specifies the offset in bits from the start of the register indicated by *RegisterAddress*. The 8-bit field *DescriptorName*. *_RBO* is automatically created in order to refer to this portion of the resource descriptor. See the *_RBO* definition in *Table: Generic Register Descriptor Definition* for more information.

RegisterAddress evaluates to a 64-bit integer that specifies the register address. The 64-bit field *DescriptorName*. *_ADR* is automatically created in order to refer to this portion of the resource descriptor. See the *_ADR* definition in *Table: Generic Register Descriptor Definition* for more information.

AccessSize evaluates to an 8-bit integer that specifies the size of data values used when accessing the address space as follows:

```
0 - Undefined (legacy)
1 - Byte access
2 - Word access
3 - DWord access
4 - QWord access
```

The 8-bit field *DescriptorName*. *_ASZ* is automatically created in order to refer to this portion of the resource descriptor. See the *_ASZ* definition in the *Generic Register Resource Descriptor* for more information. For backwards compatibility, the *AccessSize* parameter is optional when invoking the *Register* macro. If the *AccessSize* parameter is not supplied then the *AccessSize* field will be set to zero. In this case, OSPM will assume the access size.

DescriptorName is an optional argument that specifies a name for an integer constant that will be created in the current scope that contains the offset of this resource descriptor within the current resource template buffer. The predefined descriptor field names may be appended to this name to access individual fields within the descriptor via the Buffer Field operators.

Description

The Register macro evaluates to a buffer that contains a generic register resource descriptor. For the format of the buffer see Section 19.6.114. This macro is designed to be used inside of a *ResourceTemplate (Resource To Buffer Conversion Macro)*.

19.6.115 Release (Release a Mutex Synchronization Object)

Syntax:

```
Release (SyncObject)
```

Arguments

SyncObject must be a mutex synchronization object.

Description

If the mutex object is owned by the current invocation, ownership for the Mutex is released once. It is fatal to release ownership on a Mutex unless it is currently owned. A Mutex must be totally released before an invocation completes.

19.6.116 Reset (Reset an Event Synchronization Object)

Syntax:

```
Reset (SyncObject)
```

Arguments

SyncObject must be an Event synchronization object.

Description

This operator is used to reset an event synchronization object to a non-signaled state. See also the Wait and Signal function operator definitions.

19.6.117 ResourceTemplate (Resource To Buffer Conversion Macro)

Syntax:

```
ResourceTemplate() {ResourceMacroList} => Buffer
```

Description

For a full definition of the ResourceTemplateTerm macro, see Section 19.3.3.

19.6.118 Return (Return from Method Execution)

Syntax:

```
Return
Return ()
Return (Arg)
```

Arguments

Arg is optional and can be any valid object or reference.

Description

Returns control to the invoking control method, optionally returning a copy of the object named in Arg. If no Arg object is specified, a Return(Zero) is generated by the ASL compiler.

Note: In the absence of an explicit Return () statement, the return value to the caller is undefined.

19.6.119 Revision (Constant Revision Integer)

Syntax:

```
Revision => Integer
```

Description

The Revision operator returns an Integer containing the current revision of the AML interpreter. Writes to this object are not allowed.

19.6.120 Scope (Open Named Scope)

Syntax:

```
Scope (Location) {ObjectList}
```

Arguments

Opens and assigns a base namespace scope to a collection of objects. All object names defined within the scope are created relative to Location. Note that Location does not have to be below the surrounding scope, but can refer to any location within the namespace. The Scope term itself does not create objects, but only locates objects within the namespace; the actual objects are created by other ASL terms.

Description

The object referred to by Location must already exist in the namespace and be one of the following object types that has a namespace scope associated with it:

- A predefined scope such as: (**root**), **_SB**, **GPE**, **_PR**, **_TZ**, etc.
- Device
- Processor
- Thermal Zone
- Power Resource

The Scope term alters the current namespace location to the existing Location. This causes the defined objects within TermList to be created relative to this new location in the namespace.

The object list is encoded as TermList, so that rather than describing a static object list, it is possible to describe a dynamic object list according to the system settings. See “*Definition Block Loading*”.

Note: When creating secondary SSDTs, it is often required to use the Scope operator to change the namespace location in order to create objects within some part of the namespace that has been defined by the main DSDT. Use the External operator to declare the scope location so that the ASL compiler will not issue an error for an undefined Location.*

Examples

The following example ASL code uses the Scope operator and creates several objects:

```
Scope (\PCI0)
{
    Name (X, 3)
    Scope (\)
    {
        Method (RQ) {Return (0)}
    }
    Name (^Y, 4)
}
```

The created objects are placed in the ACPI namespace as shown:

```
\\PCI0.X
\\RQ
\\Y
```

The following example shows the use of External in conjunction with Scope within an SSDT:

```
DefinitionBlock ("ssdt.aml", "SSDT", 2, "X", "Y", 0x00000001)
{
    External (\_SB.PCI0, DeviceObj)
    Scope (\_SB.PCI0)
    {
    }
}
```

19.6.121 ShiftLeft (Integer Shift Left)

Syntax:

```
ShiftLeft (Source, ShiftCount, Result) => Integer
Result = Source << shiftcount => Integer
Result <<= shiftcount => Integer
```

Arguments

Source and ShiftCount are evaluated as Integers.

Description

Source is shifted left with the least significant bit zeroed ShiftCount times. The result is optionally stored into Result.

19.6.122 ShiftRight (Integer Shift Right)

Syntax:

```
ShiftRight (Source, ShiftCount, Result) => Integer
Result = Source >> ShiftCount => Integer
Result >>= ShiftCount => Integer
```

Arguments

Source and *ShiftCount* are evaluated as Integers.

Description

Source is shifted right with the most significant bit zeroed ShiftCount times. The result is optionally stored into Result.

19.6.123 Signal (Signal a Synchronization Event)

Syntax:

```
Signal (SyncObject)
```

Arguments

SyncObject must be an Event synchronization object.

Description

The Event object is signaled once, allowing one invocation to acquire the event.

19.6.124 SizeOf (Get Data Object Size)

Syntax:

```
SizeOf (ObjectName) => Integer
```

Arguments

ObjectName must be a buffer, string or package object.

Description

Returns the size of a buffer, string, or package data object.

For a buffer, it returns the size in bytes of the data. For a string, it returns the size in bytes of the string, not counting the trailing NULL. For a package, it returns the number of elements. For an object reference, the size of the referenced object is returned. Other data types cause a fatal run-time error.

19.6.125 Sleep (Milliseconds Sleep)

Syntax:

```
Sleep (MilliSeconds)
```

Arguments

The Sleep term is used to implement long-term timing requirements. Execution is delayed for at least the required number of milliseconds.

Description

The implementation of Sleep is to round the request up to the closest sleep time supported by the OS and relinquish the processor.

19.6.126 SPISerialBusV2 (SPI Serial Bus Connection Resource Descriptor (Version 2) Macro)

Syntax:

```
SPISerialBusV2 (DeviceSelection, DeviceSelectionPolarity, WireMode, DataBitLength, ↵  
↵SlaveMode, ConnectionSpeed,  
ClockPolarity, ClockPhase, ResourceSource, ResourceSourceIndex, ResourceUsage, ↵  
↵DescriptorName, Shared, VendorData)
```

Arguments

DeviceSelection is the device selection value. This value may refer to a chip-select line, GPIO line or other line selection mechanism. *_ADR* is automatically created to refer to this portion of the resource descriptor.

DeviceSelectionPolarity is an optional argument and can be either *PolarityHigh* or *PolarityLow* to indicate that the device is active. *PolarityLow* is the default. The bit field *_DPL* is automatically created to refer to this portion of the resource descriptor.

WireMode is an optional argument and can be either *ThreeWireMode* or *FourWireMode*. *FourWireMode* is the default. The bit field name *_MOD* is automatically created to refer to this portion of the resource descriptor.

DataBitLength is the size, in bits, of the smallest transfer unit for this connection. *_LEN* is automatically created to refer to this portion of the resource descriptor.

SlaveMode is an optional argument and can be either *ControllerInitiated* or *DeviceInitiated*. *ControllerInitiated* is the default. The bit field name *_SLV* is automatically created to refer to this portion of the resource descriptor.

ConnectionSpeed is the maximum connection speed supported by this connection, in hertz. The bit field name *_SPE* is automatically created to refer to this portion of the resource descriptor.

ClockPolarity can be either *ClockPolarityLow* or *ClockPolarityHigh*. *_POL* is automatically created to refer to this portion of the resource descriptor.

ClockPhase can be either *ClockPhaseFirst* or *ClockPhaseSecond*. *_PHA* is automatically created to refer to this portion of the resource descriptor.

ResourceSource is a string which uniquely identifies the SPI bus controller referred to by this descriptor. *ResourceSource* can be a fully-qualified name, a relative name or a name segment that utilizes the namespace search rules.

ResourceSourceIndex is an optional argument and is assumed to be 0 for this revision.

ResourceUsage is an optional argument and is assumed to be *ResourceConsumer* for this revision. *DescriptorName* is an optional argument that specifies a name for an integer constant that will be created in the current scope that contains

the offset of this resource descriptor within the current resource template buffer. The predefined descriptor field names may be appended to this name to access individual fields within the descriptor via the Buffer Field operators.

Shared is an optional argument and can be either *Shared* or *Exclusive*. If not specified, *Exclusive* is assumed. The bit field name `_SHR` is automatically created to refer to this portion of the resource descriptor.

VendorData is an optional argument that specifies an object to be decoded by the OS driver. It is a *RawDataBuffer*. The bit field name `_VEN` is automatically created to refer to this portion of the resource descriptor.

Description

The *SPISerialBusV2* macro evaluates to a buffer that contains an *SPI Serial Bus Connection Resource Descriptor*. This macro is designed to be used inside of a *ResourceTemplate (Resource To Buffer Conversion Macro)*.

19.6.127 Stall (Stall for a Short Time)

Syntax:

```
Stall (MicroSeconds)
```

Arguments

The *Stall* term is used to implement short-term timing requirements. Execution is delayed for at least the required number of microseconds.

Description

The implementation of *Stall* is OS-specific, but must not relinquish control of the processor. Because of this, delays longer than 100 microseconds must use *Sleep* instead of *Stall*.

19.6.128 StartDependentFn (Start Dependent Function Resource Descriptor Macro)

Syntax:

```
StartDependentFn (CompatibilityPriority, PerformancePriority) {ResourceList}
```

Arguments

CompatibilityPriority indicates the relative compatibility of the configuration specified by *ResourceList* relative to the PC/AT. 0 = Good, 1 = Acceptable, 2 = Sub-optimal.

PerformancePriority indicates the relative performance of the configuration specified by *ResourceList* relative to the other configurations. 0 = Good, 1 = Acceptable, 2 = Sub-optimal.

ResourceList is a list of resources descriptors which must be selected together for this configuration.

Description

The *StartDependentFn* macro evaluates to a buffer that contains a start dependent function resource descriptor, which describes a group of resources which must be selected together. Each subsequent *StartDependentFn* or *StartDependentFnNoPri* resource descriptor introduces a new choice of resources for configuring the device, with the last choice terminated with an *EndDependentFn* resource descriptor. The format of the start dependent function resource descriptor can be found in Section 6.4.2.3. This macro generates the two-byte form of the resource descriptor, and is designed to be used inside of a *ResourceTemplate (Resource To Buffer Conversion Macro)*.

19.6.129 StartDependentFnNoPri (Start Dependent Function Resource Descriptor Macro)

Syntax:

```
StartDependentFnNoPri () {ResourceList}
```

Description

The StartDependentFnNoPri macro evaluates to a buffer that contains a start dependent function resource descriptor, which describes a group of resources which must be selected together. Each subsequent StartDependentFn or StartDependentFnNoPri resource descriptor introduces a new choice of resources for configuring the device, with the last choice terminated with an EndDependentFn resource descriptor. The format of the start dependent function resource descriptor can be found in [Section 6.4.2.3](#). This macro generates the one-byte form of the resource descriptor, and is designed to be used inside of a *ResourceTemplate (Resource To Buffer Conversion Macro)*.

This is similar to *StartDependentFn* with both CompatibilityPriority and PerformancePriority set to 1, but is one byte shorter.

19.6.130 Store (Store an Object)

Syntax:

```
Store (Source, Destination) => DataRefObject Destination = Source => DataRefObject
```

Arguments

This operation evaluates Source, converts it to the data type of Destination, and writes the result into Destination. For information on automatic data-type conversion, see [Section 19.3.5](#)

Description

Stores to OperationRegion Field data types may relinquish the processor depending on the address space.

All stores (of any type) to the constant Zero, constant One, or constant Ones object are not allowed. Stores to read-only objects are fatal. The execution result of the operation depends on the type of Destination. For any type other than an operation region field, the execution result is the same as the data written to Destination. For operation region fields with an AccessType of ByteAcc, WordAcc, DWordAcc, QWordAcc or AnyAcc, the execution result is the same as the data written to Destination as in the normal case, but when the AccessType is BufferAcc, the operation region handler may modify the data when it is written to the Destination so that the execution result contains modified data.

Example

The following example creates the name CNT that references an integer data object with the value 5 and then stores CNT to Local0. After the Store operation, Local0 is an integer object with the value 5:

```
Name (CNT, 5)
Store (CNT, Local0)
```

19.6.131 Subtract (Integer Subtract)

Syntax:

```
Subtract ( Minuend, Subtrahend, Result ) => Integer
Result = Minuend - Subtrahend => Integer
Result -= Subtrahend => Integer
```

Arguments

Minuend and Subtrahend are evaluated as Integers.

Description

Subtrahend is subtracted from Minuend, and the result is optionally stored into Result. Underflow conditions are ignored and the result simply loses the most significant bits.

19.6.132 Switch (Select Code To Execute Based On Expression)

Syntax:

```
Switch (Expression) {CaseTermList}
```

Arguments

Expression is an ASL expression that evaluates to an Integer, String or Buffer.

Description

The Switch, Case and Default statements help simplify the creation of conditional and branching code. The Switch statement transfers control to a statement within the enclosed body of executable ASL code

If the Case Value is an Integer, Buffer or String, then control passes to the statement that matches the value of Switch (Expression). If the Case value is a Package, then control passes if any member of the package matches the Switch (Value) The Switch CaseTermList can include any number of Case instances, but no two Case Values (or members of a Value, if Value is a Package) within the same Switch statement can have the same value.

Execution of the statement body begins at the selected TermList and proceeds until the TermList end of body or until a Break or Continue statement transfers control out of the body.

The Default statement is executed if no Case Value matches the value of Switch (expression). If the Default statement is omitted, and no Case match is found, none of the statements in the Switch body are executed. There can be at most one Default statement. The Default statement can appear anywhere in the body of the Switch statement.

A Case or Default term can only appear inside a Switch statement. Switch statements can be nested. (Compatibility Note) The Switch, Case, and Default terms were first introduced in ACPI 2.0. However, their implementation is backward compatible with ACPI 1.0 AML interpreters.

Example

Use of the Switch statement usually looks something like this:

```
Switch (expression)
{
  Case (value) {
    Statements executed if Lequal (expression, value)
  }
  Case (Package () {value, value, value}) {
    Statements executed if Lequal (expression, any value in package)
  }
}
```

(continues on next page)

(continued from previous page)

```

Default {
    Statements executed if expression does not equal any case constant-expression
}
}

```

Note: Compiler Note: The following example demonstrates how the Switch statement should be translated into ACPI 1.0-compatible AML:

```

Switch (Add (ABCD ( ), 1)
{
    Case (1) {
        ...statements1...
    }
    Case (Package () {4,5,6}) {
        ...statements2...
    }
    Default {
        ...statements3...
    }
}

```

is translated as:

```

Name (_T_I, 0) // Create Integer temporary variable for result
While (One)
{
    Store (Add (ABCD (), 1), \_T_I)
    If (LEqual (_T_I, 1)) {
        ...statements1...
    }
    Else {
        If (LNotEqual (Match (Package () {4, 5, 6}, MEQ, \_T_I, MTR, 0, 0), Ones)) {
            ...statements2...
        }
        Else {
            ...statements3...
        }
    }
    Break
}

```

The While (One) is emitted to enable the use of Break and Continue within the Switch statement. Temporary names emitted by the ASL compiler should appear at the top level of the method, since the Switch statement could appear within a loop and thus attempt to create the name more than once.

Note: If the ASL compiler is unable to determine the type of the expression, then it will generate a warning and assume a type of Integer. The warning will indicate that the code should use one of the type conversion operators (Such as ToInteger, ToBuffer, ToDecimalString or ToHexString). Caution: Some of these operators are defined starting with ACPI 2.0 and as such may not be supported by ACPI 1.0b compatible interpreters.

For example:

```

Switch (ABCD ()) // Cannot determine the type because methods can return anything.
{
    ...case statements...
}

```

will generate a warning and the following code:

```
Name (_T_I, 0)
Store (ABCD (), \_T_I)
```

To remove the warning, the code should be:

```
Switch (ToInteger (ABCD ()))
{
    ...case statements...
}
```

19.6.133 ThermalZone (Declare Thermal Zone)

Syntax:

```
ThermalZone (ThermalZoneName) {TermList}
```

Arguments

Declares a Thermal Zone object named ThermalZoneName. ThermalZone opens a name scope.

Each use of a ThermalZone term declares one thermal zone in the system. Each thermal zone in a system is required to have a unique ThermalZoneName.

Description

A thermal zone may be declared in the namespace anywhere within the _SB scope. For compatibility with operating systems implementing ACPI 1.0, a thermal zone may also be declared under the _TZ scope. An ACPI-compatible namespace may define Thermal Zone objects in either the _SB or _TZ scope but not both.

For example ASL code that uses a ThermalZone statement, see [Section 11](#)

The thermal object list is encoded as TermList, so that rather than describing a static thermal object list, it is possible to describe a dynamic thermal object list according to the system settings. See “*Definition Block Loading*”.

19.6.134 Timer (Get 64-Bit Timer Value)

Syntax:

```
Timer => Integer
```

Description

The timer opcode returns a monotonically increasing value that can be used by ACPI methods to measure time passing, this enables speed optimization by allowing AML code to mark the passage of time independent of OS ACPI interpreter implementation.

The Sleep opcode can only indicate waiting for longer than the time specified.

The value resulting from this opcode is 64 bits. It is monotonically increasing, but it is not guaranteed that every result will be unique, i.e. two subsequent instructions may return the same value. The only guarantee is that each subsequent evaluation will be greater-than or equal to the previous ones.

The period of this timer is 100 nanoseconds. While the underlying hardware may not support this granularity, the interpreter will do the conversion from the actual timer hardware frequency into 100 nanosecond units.

Users of this opcode should realize that a value returned only represents the time at which the opcode itself executed. There is no guarantee that the next opcode in the instruction stream will execute in any particular time bound.

The OSPM can implement this using the ACPI Timer and keep track of overrun. Other implementations are possible. This provides abstraction away from chipset differences

Note: **Compatibility Note** New for ACPI 3.0

19.6.135 ToBCD (Convert Integer to BCD)

Syntax:

```
ToBCD (Value, Result) => Integer
```

Arguments

Value is evaluated as an integer

Description

The ToBCD operator is used to convert *Value* from a numeric (Integer) format to a BCD format and optionally store the numeric value into *Result*.

19.6.136 ToBuffer (Convert Data to Buffer)

Syntax:

```
ToBuffer (Data, Result) => Buffer
```

Arguments

Data must be an Integer, String, or Buffer data type.

Description

Data is converted to buffer type and the result is optionally stored into *Result*. If *Data* is an integer, it is converted into *n* bytes of buffer (where *n* is 4 if the definition block has defined integers as 32 bits or 8 if the definition block has defined integers as 64 bits as indicated by the Definition Block table header's Revision field), taking the least significant byte of integer as the first byte of buffer. If *Data* is a buffer, no conversion is performed. If *Data* is a string, each ASCII string character is copied to one buffer byte, including the string null terminator. A null (zero-length) string will be converted to a zero-length buffer.

19.6.137 ToDecimalString (Convert Data to Decimal String)

Syntax:

```
ToDecimalString (Data, Result) => String
```

Arguments

Data must be an Integer, String, or Buffer data type.

Description

Data is converted to a decimal string, and the result is optionally stored into *Result*. If *Data* is already a string, no action is performed. If *Data* is a buffer, it is converted to a string of decimal values separated by commas. (Each byte of the buffer is converted to a single decimal value.) A zero-length buffer will be converted to a null (zero-length) string.

19.6.138 ToHexString (Convert Data to Hexadecimal String)

Syntax:

```
ToHexString (Data, Result) => String
```

Arguments

Data must be an Integer, String, or Buffer data type.

Description

Data is converted to a hexadecimal string, and the result is optionally stored into Result. If Data is already a string, no action is performed. If Data is a buffer, it is converted to a string of hexadecimal values separated by commas. A zero-length buffer will be converted to a null (zero-length) string.

19.6.139 ToInteger (Convert Data to Integer)

Syntax:

```
ToInteger (Data, Result) => Integer
```

Arguments

Data must be an Integer, String, or Buffer data type.

Description

Data is converted to integer type and the result is optionally stored into Result. If Data is a string, it must be either a decimal or hexadecimal numeric string (in other words, prefixed by “0x”) and the value must not exceed the maximum of an integer value. If the value is exceeding the maximum, the result of the conversion is unpredictable. A null (zero-length) string is illegal. If Data is a Buffer, the first 8 bytes of the buffer are converted to an integer, taking the first byte as the least significant byte of the integer. A zero-length buffer is illegal. If Data is an integer, no action is performed.

19.6.140 ToPLD (Creates a _PLD Buffer Object)

Syntax:

```
ToPLD (PLDKeywordList) => \_PLD Buffer Object
```

Arguments

PLDKeywordList is a list of *PLDKeyword* types that describe elements of a Physical Layer Description (_PLD) buffer that can be assigned values. The table below shows the available *PLDKeyword* types and their assignable types. Refer to the _PLD section for a description of the _PLD method object.

Table 19.39: **PLD Keywords and Assignment Types**

PLDKeyword	Assignment Type
PLD_Revision	Integer
PLD_IgnoreColor	Integer
PLD_Red	Integer
PLD_Green	Integer
PLD_Blue	Integer
PLD_Width	Integer

continues on next page

Table 19.39 – continued from previous page

PLDKeyword	Assignment Type
PLD_Height	Integer
PLD_UserVisible	Integer
PLD_Dock	Integer
PLD_Lid	Integer
PLD_Panel	Integer or String
PLD_VerticalPosition	Integer or String
PLD_HorizontalPosition	Integer or String
PLD_Shape	Integer or String
PLD_GroupOrientation	Integer
PLD_GroupToken	Integer
PLD_GroupPosition	Integer
PLD_Bay	Integer
PLD_Ejectable	Integer
PLD_EjectRequired	Integer
PLD_CabinetNumber	Integer
PLD_CardCageNumber	Integer
PLD_Reference	Integer
PLD_Rotation	Integer
PLD_Order	Integer
PLD_VeriticalOffset	Integer
PLD_HorizontalOffset	Integer

A subset of PLDKeyword types can be assigned string values for improved readability. Those types and their assignable values are shown in the table below.

Table 19.40: PLD Keywords and assignable String Values

PLDKeyword	Assignable String Values
PLD_Panel	“TOP”, “BOTTOM”, “LEFT”, “RIGHT”, “FRONT”, “BACK”, “UNKNOWN”
PLD_VerticalPosition	“UPPER”, “CENTER”, “LOWER”
PLD_HorizontalPosition	“LEFT”, “CENTER”, “RIGHT”
PLD_Shape	“ROUND”, “OVAL”, “SQUARE”, “VERTICALRECTANGLE”, “HORIZONTALRECTANGLE”, “VERTICALTRAPEZOID”, “HORIZONTALTRAPEZOID”, “UNKNOWN”

Description

The ToPLD macro converts a list of PLDKeyword types into a _PLD buffer object.

Example

The following ASL shows an example using ToPLD to construct a _PLD buffer/package object:

```
Name (_PLD, Package (0x01) // \_PLD: Physical Location of Device
{
    ToPLD (
        PLD_Revision = 0x2,
        PLD_IgnoreColor = 0x1,
        PLD_Red = 0x37,
        PLD_Green = 0x44,
        PLD_Blue = 0xFF,
        PLD_Width = 0x4,
        PLD_Height = 0x19,
```

(continues on next page)

(continued from previous page)

```

    PLD_UserVisible = 0x1,
    PLD_Dock = 0x0,
    PLD_Lid = 0x1,
    PLD_Panel = "TOP",
    PLD_VerticalPosition = "CENTER",
    PLD_HorizontalPosition = "RIGHT",
    PLD_Shape = "VERTICALRECTANGLE",
    PLD_GroupOrientation = 0x1,
    PLD_GroupToken = 0xA,
    PLD_GroupPosition = 0x21,
    PLD_Bay = 0x1,
    PLD_Ejectable = 0x0,
    PLD_EjectRequired = 0x1,
    PLD_CabinetNumber = 0x1E,
    PLD_CardCageNumber = 0x17,
    PLD_Reference = 0x0,
    PLD_Rotation = 0x7,
    PLD_Order = 0x3,
    PLD_VerticalOffset = 0x141,
    PLD_HorizontalOffset = 0x2C
)
}
)

```

19.6.141 ToString (Convert Buffer To String)

Syntax:

```
ToString (Source, Length, *Result) => String
```

Arguments

Source is evaluated as a buffer. *Length* is evaluated as an integer data type.

Description

Starting with the first byte, the contents of the buffer are copied into the string until the number of characters specified by *Length* is reached or a null (0) character is found. If *Length* is not specified or is *Ones*, then the contents of the buffer are copied until a null (0) character is found. If the source buffer has a length of zero, a zero length (null terminator only) string will be created. The result is copied into the *Result*.

19.6.142 ToUUID (Convert String to UUID Macro)

Syntax:

```
ToUUID (AsciiString) => Buffer
```

Arguments

AsciiString is evaluated as a String data type.

Description

This macro will convert an ASCII string to a 128-bit buffer. The string must have the following format:

```
aabbccdd-eeff-gghh-ijjj-kkllmmnnoopp
```

where aa - pp are one byte hexadecimal numbers, made up of hexadecimal digits. The resulting buffer has the format shown in the following table:

Table 19.41: UUID Buffer Format

String	Offset In Buffer
aa	3
bb	2
cc	1
dd	0
ee	5
ff	4
gg	7
hh	6
ii	8
jj	9
kk	10
ll	11
mm	12
nn	13
oo	14
pp	15

Note: **Compatibility Note:** New for ACPI 3.0

19.6.143 UARTSerialBusV2 (UART Serial Bus Connection Resource Descriptor Version 2 Macro)

Syntax:

```
UARTSerialBusV2 (InitialBaudRate, BitsPerByte, StopBits, LinesInUse, IsBigEndian, ↵
↵Parity, FlowControl, ReceiveBufferSize,
TransmitBufferSize, ResourceSource, ResourceSourceIndex, ResourceUsage, ↵
↵DescriptorName, Shared, VendorData)
```

Arguments

InitialBaudRate evaluates to a 32-bit integer that specifies the default or initial connection speed in bytes per second that the device supports. The bit field *_SPE* is automatically created to refer to this portion of the resource descriptor.

BitsPerByte is an optional argument that specifies whether five bits (*DataBitsFive*), six bits (*DataBitsSix*), seven bits (*DataBitsSeven*), eight bits (*DataBitsEight*) or nine bits (*DataBitsNine*) contain data during transfer of a single packet or character. *DataBitsEight* is the default. The bit field *DescriptorName._LEN* is automatically created to refer to this portion of the resource descriptor.

StopBits is an optional argument that specifies whether there are two bits (*StopBitsTwo*), one and a half bits (*StopBitsOnePlusHalf*), one bit (*StopBitsOne*) or no bits (*StopBitsZero*) used to signal the end of a packet or character. *StopBitsOne* is the default. The bit field *_STB* is automatically created to refer to this portion of the resource descriptor.

LinesInUse evaluates to an integer representing 8 1-bit flags representing the presence ('1') or absence ('0') of a particular line. The bit field *_LIN* is automatically created to refer to this portion of the resource descriptor.

Table 19.42: UART Serial Bus Connection Resource Descriptor - Version 2 Macro

Bit Mask	UART Line
Bit 7 (0x80)	Request To Send (RTS)
Bit 6 (0x40)	Clear To Send (CTS)
Bit 5 (0x20)	Data Terminal Ready (DTR)
Bit 4 (0x10)	Data Set Ready (DSR)
Bit 3 (0x08)	Ring Indicator (RI)
Bit 2 (0x04)	Data Carrier Detect (DTD)
Bit 1 (0x02)	Reserved. Must be 0.
Bit 0 (0x01)	Reserved. Must be 0.

IsBigEndian is an optional argument that specifies whether the device is expecting big endian (BigEndian) or little endian (LittleEndian) data formats. LittleEndian is the default. The bit field *_END* is automatically created to refer to this portion of the resource descriptor.

Parity is an optional argument that specifies whether the type of parity bits included after the data in a packet are to be interpreted as space parity (ParityTypeSpace), mark parity (ParityTypeMark), odd parity (ParityTypeOdd), even parity (ParityTypeEven) or no parity (ParityTypeNone). ParityTypeNone is the default. The bit field *PAR* is automatically created to refer to this portion of the resource descriptor.

FlowControl is an optional argument that specifies whether there is hardware-based flow control (FlowControlHardware), software-based flow control (FlowControlXON) or no flow control (FlowControlNone) used when communicating with the device. FlowControlNone is the default. The bit field *_FLC* is automatically created to refer to this portion of the resource descriptor.

ReceiveBufferSize evaluates to a 16-bit integer that specifies the upper limit in bytes of the receive buffer that can be optimally utilized while communicating with this device. The bit field *_RXL* is automatically created to refer to this portion of the resource descriptor.

TransmitBufferSize evaluates to a 16-bit integer that specifies the upper limit in bytes of the transmit buffer that can be optimally utilized while communicating with this device. The bit field *_TXL* is automatically created to refer to this portion of the resource descriptor.

ResourceSource is a string which uniquely identifies the UART bus controller referred to by this descriptor. ResourceSource can be a fully-qualified name, a relative name or a name segment that utilizes the namespace search rules.

ResourceSourceIndex is an optional argument and is assumed to be 0 for this revision.

ResourceUsage is an optional argument and is assumed to be ResourceConsumer for this revision.

DescriptorName is an optional argument that specifies a name for an integer constant that will be created in the current scope that contains the offset of this resource descriptor within the current resource template buffer. The predefined descriptor field names may be appended to this name to access individual fields within the descriptor via the Buffer Field operators.

Shared is an optional argument and can be either Shared or Exclusive. If not specified, Exclusive is assumed. The bit field name *_SHR* is automatically created to refer to this portion of the resource descriptor.

VendorData is an optional argument that specifies an object to be decoded by the OS driver. It is a RawDataBuffer. The bit field name *_VEN* is automatically created to refer to this portion of the resource descriptor.

Description

The UARTSerialBusV2 macro evaluates to a buffer that contains a *UART Serial Bus Connection Resource Descriptor - Version 2 Macro*. This macro is designed to be used inside of a *ResourceTemplate (Resource To Buffer Conversion*

Macro).

19.6.144 Unicode (String To Unicode Conversion Macro)

Syntax:

```
Unicode (String) => Buffer
```

Arguments

This macro will convert a string to a Unicode (UTF-16) string contained in a buffer. The format of the Unicode string is 16 bits per character, with a 16-bit null terminator.

19.6.145 VendorLong (Long Vendor Resource Descriptor)

Syntax:

```
VendorLong (DescriptorName) {VendorByteList}
```

Arguments

DescriptorName is an optional argument that specifies a name for an integer constant that will be created in the current scope that contains the offset of this resource descriptor within the current resource template buffer.

VendorByteList evaluates to a comma-separated list of 8-bit integer constants, where each byte is added verbatim to the body of the VendorLong resource descriptor. A maximum of n bytes can be specified. UUID and UUID specific descriptor subtype are part of the VendorByteList.

Description

The VendorLong macro evaluates to a buffer that contains a vendor-defined resource descriptor. The long form of the vendor-defined resource descriptor can be found in [Section 6.4.3.2](#). This macro is designed to be used inside of a *ResourceTemplate (Resource To Buffer Conversion Macro)*.

This is similar to *VendorShort*, except that the number of allowed bytes in VendorByteList is 65,533 (instead of 7).

19.6.146 VendorShort (Short Vendor Resource Descriptor)

Syntax:

```
VendorShort (DescriptorName) {VendorByteList}
```

Arguments

DescriptorName is an optional argument that specifies a name for an integer constant that will be created in the current scope that contains the offset of this resource descriptor within the current resource template buffer.

Description

The VendorShort macro evaluates to a buffer that contains a vendor-defined resource descriptor. The short form of the vendor-defined resource descriptor can be found in [Section 6.4.2.8](#). This macro is designed to be used inside of a *ResourceTemplate (Resource To Buffer Conversion Macro)*.

This is similar to *VendorLong*, except that the number of allowed bytes in VendorByteList is 7 (instead of 65,533).

19.6.147 Wait (Wait for a Synchronization Event)

Syntax:

```
Wait (SyncObject, TimeoutValue) => Boolean
```

Arguments

SynchObject must be an event synchronization object. *TimeoutValue* is evaluated as an Integer. The calling method blocks while waiting for the event to be signaled.

Description

The pending signal count is decremented. If there is no pending signal count, the processor is relinquished until a signal count is posted to the Event or until at least *TimeoutValue* milliseconds have elapsed.

This operation returns a non-zero value if a timeout occurred and a signal was not acquired. A *TimeoutValue* of 0xFFFF (or greater) indicates that there is no time out and the operation will wait indefinitely.

19.6.148 While (Conditional Loop)

Syntax:

```
While (Predicate) {TermList}
```

Arguments

Predicate is evaluated as an integer.

Description

If the *Predicate* is non-zero, the list of terms in *TermList* is executed. The operation repeats until the *Predicate* evaluates to zero.

Note: Creation of a named object more than once in a given scope is not allowed. As such, unconditionally creating named objects within a *While* loop must be avoided. A fatal error will be generated on the second iteration of the loop, during the attempt to create the same named object a second time.

19.6.149 WordBusNumber (Word Bus Number Resource Descriptor Macro)

Syntax:

```
WordBusNumber (ResourceUsage, IsMinFixed, IsMaxFixed, Decode, AddressGranularity,
↪AddressMinimum, AddressMaximum,
AddressTranslation, RangeLength, ResourceSourceIndex, ResourceSource, DescriptorName)
```

Arguments

ResourceUsage specifies whether the bus range is consumed by this device (ResourceConsumer) or passed on to child devices (ResourceProducer). If nothing is specified, then ResourceConsumer is assumed.

IsMinFixed specifies whether the minimum address of this bus number range is fixed (MinFixed) or can be changed (MinNotFixed). If nothing is specified, then MinNotFixed is assumed. The 1-bit field *DescriptorName*. *_MIF* is automatically created to refer to this portion of the resource descriptor, where '1' is MinFixed and '0' is MinNotFixed.

IsMaxFixed specifies whether the maximum address of this bus number range is fixed (MaxFixed) or can be changed (MaxNotFixed). If nothing is specified, then MaxNotFixed is assumed. The 1-bit field *DescriptorName*. *_MAF* is automatically created to refer to this portion of the resource descriptor, where '1' is MaxFixed and '0' is MaxNotFixed.

Decode specifies whether or not the device decodes the bus number range using positive (PosDecode) or subtractive (SubDecode) decode. If nothing is specified, then PosDecode is assumed. The 1-bit field DescriptorName. _DEC is automatically created to refer to this portion of the resource descriptor, where '1' is SubDecode and '0' is PosDecode.

AddressGranularity evaluates to a 16-bit integer that specifies the power-of-two boundary (- 1) on which the bus number range must be aligned. The 16-bit field DescriptorName. _GRA is automatically created to refer to this portion of the resource descriptor.

AddressMinimum evaluates to a 16-bit integer that specifies the lowest possible bus number for the bus number range. The value must have '0' in all bits where the corresponding bit in AddressGranularity is '1'. For bridge devices which translate addresses, this is the address on the secondary bus. The 16-bit field DescriptorName._MIN is automatically created to refer to this portion of the resource descriptor.

AddressMaximum evaluates to a 16-bit integer that specifies the highest possible bus number for the bus number range. The value must have '0' in all bits where the corresponding bit in AddressGranularity is '1'. For bridge devices which translate addresses, this is the address on the secondary bus. The 16-bit field DescriptorName._MAX is automatically created to refer to this portion of the resource descriptor.

AddressTranslation evaluates to a 16-bit integer that specifies the offset to be added to a secondary bus bus number which results in the corresponding primary bus bus number. For all non-bridge devices or bridges which do not perform translation, this must be '0'. The 16-bit field DescriptorName._TRA is automatically created to refer to this portion of the resource descriptor.

RangeLength evaluates to a 16-bit integer that specifies the total number of bus numbers decoded in the bus number range. The 16-bit field DescriptorName. _LEN is automatically created to refer to this portion of the resource descriptor.

ResourceSourceIndex is an optional argument which evaluates to an 8-bit integer that specifies the resource descriptor within the object specified by ResourceSource. If this argument is specified, the ResourceSource argument must also be specified.

ResourceSource is an optional argument which evaluates to a string containing the path of a device which produces the pool of resources from which this I/O range is allocated. If this argument is specified, but the ResourceSourceIndex argument is not specified, a zero value is assumed.

DescriptorName is an optional argument that specifies a name for an integer constant that will be created in the current scope that contains the offset of this resource descriptor within the current resource template buffer. The predefined descriptor field names may be appended to this name to access individual fields within the descriptor via the Buffer Field operators.

Description

The WordBusNumber macro evaluates to a buffer that contains a 16-bit bus-number resource descriptor. The format of the 16-bit bus number resource descriptor can be found in Section 6.4.3.5.3. This macro is designed to be used inside of a *ResourceTemplate (Resource To Buffer Conversion Macro)*.

19.6.150 WordIO (Word IO Resource Descriptor Macro)

Syntax:

```
WordIO (ResourceUsage, IsMinFixed, IsMaxFixed, Decode, ISARanges, AddressGranularity, ↵
↵AddressMinimum, AddressMaximum,
AddressTranslation, RangeLength, ResourceSourceIndex, ResourceSource, DescriptorName, ↵
↵TranslationType, TranslationDensity)
```

Arguments

ResourceUsage specifies whether the I/O range is consumed by this device (ResourceConsumer) or passed on to child devices (ResourceProducer). If nothing is specified, then ResourceConsumer is assumed.

IsMinFixed specifies whether the minimum address of this I/O range is fixed (MinFixed) or can be changed (MinNotFixed). If nothing is specified, then MinNotFixed is assumed. The 1-bit field DescriptorName. `_MIF` is automatically created to refer to this portion of the resource descriptor, where '1' is MinFixed and '0' is MinNotFixed.

IsMaxFixed specifies whether the maximum address of this I/O range is fixed (MaxFixed) or can be changed (MaxNotFixed). If nothing is specified, then MaxNotFixed is assumed. The 1-bit field DescriptorName. `_MAF` is automatically created to refer to this portion of the resource descriptor, where '1' is MaxFixed and '0' is MaxNotFixed.

Decode specifies whether or not the device decodes the I/O range using positive (PosDecode) or subtractive (SubDecode) decode. If nothing is specified, then PosDecode is assumed. The 1-bit field DescriptorName. `_DEC` is automatically created to refer to this portion of the resource descriptor, where '1' is SubDecode and '0' is PosDecode.

ISARanges specifies whether the I/O ranges specifies are limited to valid ISA I/O ranges (ISAOnly), valid non-ISA I/O ranges (NonISAOnly) or encompass the whole range without limitation (EntireRange). The 2-bit field DescriptorName. `_RNG` is automatically created to refer to this portion of the resource descriptor, where '1' is NonISAOnly, '2' is ISAOnly and '0' is EntireRange.

AddressGranularity evaluates to a 16-bit integer that specifies the power-of-two boundary (- 1) on which the I/O range must be aligned. The 16-bit field DescriptorName. `_GRA` is automatically created to refer to this portion of the resource descriptor.

AddressMinimum evaluates to a 16-bit integer that specifies the lowest possible base address of the I/O range. The value must have '0' in all bits where the corresponding bit in AddressGranularity is '1'. For bridge devices which translate addresses, this is the address on the secondary bus. The 16-bit field DescriptorName. `_MIN` is automatically created to refer to this portion of the resource descriptor.

AddressMaximum evaluates to a 16-bit integer that specifies the highest possible base address of the I/O range. The value must have '0' in all bits where the corresponding bit in AddressGranularity is '1'. For bridge devices which translate addresses, this is the address on the secondary bus. The 16-bit field DescriptorName. `_MAX` is automatically created to refer to this portion of the resource descriptor.

AddressTranslation evaluates to a 16-bit integer that specifies the offset to be added to a secondary bus I/O address which results in the corresponding primary bus I/O address. For all non-bridge devices or bridges which do not perform translation, this must be '0'. The 16-bit field DescriptorName. `_TRA` is automatically created to refer to this portion of the resource descriptor.

RangeLength evaluates to a 16-bit integer that specifies the total number of bytes decoded in the I/O range. The 16-bit field DescriptorName. `_LEN` is automatically created to refer to this portion of the resource descriptor.

ResourceSourceIndex is an optional argument which evaluates to an 8-bit integer that specifies the resource descriptor within the object specified by ResourceSource. If this argument is specified, the ResourceSource argument must also be specified.

ResourceSource is an optional argument which evaluates to a string containing the path of a device which produces the pool of resources from which this I/O range is allocated. If this argument is specified, but the ResourceSourceIndex argument is not specified, a zero value is assumed.

DescriptorName is an optional argument that specifies a name for an integer constant that will be created in the current scope that contains the offset of this resource descriptor within the current resource template buffer. The predefined descriptor field names may be appended to this name to access individual fields within the descriptor via the Buffer Field operators.

TranslationType is an optional argument that specifies whether the resource type on the secondary side of the bus is different (TypeTranslation) from that on the primary side of the bus or the same (TypeStatic). If TypeTranslation is specified, then the primary side of the bus is Memory. If TypeStatic is specified, then the primary side of the bus is I/O. If nothing is specified, then TypeStatic is assumed. The 1-bit field DescriptorName. `_TTP` is automatically created to refer to this portion of the resource descriptor, where '1' is TypeTranslation and '0' is TypeStatic. See `_TTP` for more information

TranslationDensity is an optional argument that specifies whether or not the translation from the primary to secondary

bus is sparse (SparseTranslation) or dense (DenseTranslation). It is only used when TranslationType is TypeTranslation. If nothing is specified, then DenseTranslation is assumed. The 1-bit field DescriptorName. _TRS is automatically created to refer to this portion of the resource descriptor, where '1' is SparseTranslation and '0' is DenseTranslation. See *_TRS* for more information.

Description

The WordIO macro evaluates to a buffer that contains a 16-bit I/O range resource descriptor. The format of the 16-bit I/O range resource descriptor can be found in Section 6.4.3.5.3. This macro is designed to be used inside of a *ResourceTemplate (Resource To Buffer Conversion Macro)*.

19.6.151 WordSpace (Word Space Resource Descriptor Macro)

Syntax:

```
WordSpace (ResourceType, ResourceUsage, Decode, IsMinFixed, IsMaxFixed, ↵
↵TypeSpecificFlags, AddressGranularity, AddressMinimum,
AddressMaximum, AddressTranslation, RangeLength, ResourceSourceIndex, ResourceSource, ↵
↵DescriptorName)
```

Arguments

ResourceType evaluates to an 8-bit integer that specifies the type of this resource. Acceptable values are 0xC0 through 0xFF.

ResourceUsage specifies whether the bus range is consumed by this device (ResourceConsumer) or passed on to child devices (ResourceProducer). If nothing is specified, then ResourceConsumer is assumed.

Decode specifies whether or not the device decodes the bus number range using positive (PosDecode) or subtractive (SubDecode) decode. If nothing is specified, then PosDecode is assumed. The 1-bit field DescriptorName. _DEC is automatically created to refer to this portion of the resource descriptor, where '1' is SubDecode and '0' is PosDecode.

IsMinFixed specifies whether the minimum address of this bus number range is fixed (MinFixed) or can be changed (MinNotFixed). If nothing is specified, then MinNotFixed is assumed. The 1-bit field DescriptorName. _MIF is automatically created to refer to this portion of the resource descriptor, where '1' is MinFixed and '0' is MinNotFixed.

IsMaxFixed specifies whether the maximum address of this bus number range is fixed (MaxFixed) or can be changed (MaxNotFixed). If nothing is specified, then MaxNotFixed is assumed. The 1-bit field DescriptorName. _MAF is automatically created to refer to this portion of the resource descriptor, where '1' is MaxFixed and '0' is MaxNotFixed.

TypeSpecificFlags evaluates to an 8-bit integer. The flags are specific to the ResourceType.

AddressGranularity evaluates to a 16-bit integer that specifies the power-of-two boundary (- 1) on which the bus number range must be aligned. The 16-bit field DescriptorName. _GRA is automatically created to refer to this portion of the resource descriptor.

AddressMinimum evaluates to a 16-bit integer that specifies the lowest possible bus number for the bus number range. The value must have '0' in all bits where the corresponding bit in AddressGranularity is '1'. For bridge devices which translate addresses, this is the address on the secondary bus. The 16-bit field DescriptorName. _MIN is automatically created to refer to this portion of the resource descriptor.

AddressMaximum evaluates to a 16-bit integer that specifies the highest possible bus number for the bus number range. The value must have '0' in all bits where the corresponding bit in AddressGranularity is '1'. For bridge devices which translate addresses, this is the address on the secondary bus. The 16-bit field DescriptorName. _MAX is automatically created to refer to this portion of the resource descriptor.

AddressTranslation evaluates to a 16-bit integer that specifies the offset to be added to a secondary bus bus number which results in the corresponding primary bus bus number. For all non-bridge devices or bridges which do not perform translation, this must be '0'. The 16-bit field DescriptorName. _TRA is automatically created to refer to this portion of the resource descriptor.

RangeLength evaluates to a 16-bit integer that specifies the total number of bus numbers decoded in the bus number range. The 16-bit field *DescriptorName*. *_LEN* is automatically created to refer to this portion of the resource descriptor.

ResourceSourceIndex is an optional argument which evaluates to an 8-bit integer that specifies the resource descriptor within the object specified by *ResourceSource*. If this argument is specified, the *ResourceSource* argument must also be specified.

ResourceSource is an optional argument which evaluates to a string containing the path of a device which produces the pool of resources from which this I/O range is allocated. If this argument is specified, but the *ResourceSourceIndex* argument is not specified, a zero value is assumed.

DescriptorName is an optional argument that specifies a name for an integer constant that will be created in the current scope that contains the offset of this resource descriptor within the current resource template buffer. The predefined descriptor field names may be appended to this name to access individual fields within the descriptor via the Buffer Field operators.

Description

The *WordSpace* macro evaluates to a buffer that contains a 16-bit Address Space resource descriptor. The format of the 16-bit Address Space resource descriptor can be found in [Section 6.4.3.5.3](#). This macro is designed to be used inside of a *ResourceTemplate* (*Resource To Buffer Conversion Macro*).

19.6.152 XOr (Integer Bitwise Xor)

Syntax:

```
XOr ( Source1, Source2, Result ) => Integer
Result = Source1 ^ Source2 => Integer
Result ^= Source => Integer
```

Arguments

Source1 and Source2 are evaluated as Integers.

Description

A bitwise XOR is performed and the result is optionally stored into Result.

19.6.153 Zero (Constant Zero Integer)

Syntax:

```
Zero => Integer
```

Description

The Zero operator returns an Integer with the value 0. Writes to this object are not allowed. The use of this operator can reduce AML code size, since it is represented by a one-byte AML opcode.

19.6.154 ClockInput (Clock Input Resource Descriptor Macro)

Syntax:

```
ClockInput (FrequencyNumerator, FrequencyDivisor, Scale, FixedMode, ResourceSource, ↵
↵ResourceSourceIndex)
```

Arguments

FrequencyNumerator is an integer argument describing the numerator of the input frequency of the clock. This argument is required. If *FixedMode* is **Variable** this value describes the initial/default input clock frequency. The unit type for the value in this argument is conveyed in *Scale*. The bit field name `_SPE` is automatically created to refer to this portion of the resource descriptor.

FrequencyDivisor is an integer argument describing the denominator of the input frequency of the clock. If *FixedMode* is **Variable** this value describes the initial/default input clock frequency.

Scale is one of Hz | kHz | MHz. This required argument conveys the unit of the frequency value determined by (*FrequencyNumerator* / *FrequencyDivisor*).

FixedMode is one of Fixed | Variable. **Fixed** denotes that the clock frequency cannot be adjusted. **Variable** denotes that the clock frequency is variable, and is controllable through the Device referenced by *ResourceSource*.

ResourceSource is a string which uniquely identifies the Device which is the source of the clock signal described by this Resource. If *FixedMode* is **Variable**, this argument is required. *ResourceSource* can be a fully-qualified name, a relative name or a name segment that utilizes the namespace search rules.

ResourceSourceIndex is an integer specifying the clock output of the Device specified by *ResourceSource*. Clock output index values begin at 0. If *FixedMode* is **Variable**, this argument is required. If *ResourceSource* is not supplied, this argument is ignored. If the clock source referenced by *ResourceSource* has only one clock output, this argument shall be 0.

Examples

The following examples show the use of the ClockInput macro for two different cases.

Case 1: Simple clock input descriptor, with a fixed frequency of 33 1/3 MHz and no Device shown as a clock source.

```
ClockInput (100, 3, MHz, Fixed,,)
```

Case 2: Clock input descriptor referencing a variable clock input of 19.2 kHz, with a source device and index.

```
ClockInput (19200, 1, Hz, Variable, "\\_SB.PCI0.CLK4", 3)
```

ACPI MACHINE LANGUAGE (AML) SPECIFICATION

This chapter formally defines the ACPI Machine Language (AML), which is the virtual machine language for ACPI control methods on an ACPI-compatible OS. ACPI control methods can be written directly in AML, but people usually write them in ASL and then compile to AML.

AML is the language processed by the ACPI AML interpreter. It is primarily a declarative language. It's best not to think of it as a stream of code, but rather as a set of declarations that the ACPI AML interpreter will compile into the ACPI Namespace at definition block load time. For example, notice that DefByte allocates an anonymous integer variable with a byte-size initial value in ACPI namespace, and passes in an initial value. The byte in the AML stream that defines the initial value is not the address of the variable's storage location.

An OEM or platform firmware vendor needs to write ASL and be able to single-step AML for debugging. (Debuggers and other ACPI control method language tools are expected to be AML-level tools, not source-level tools.) An ASL translator implementer must understand how to read ASL and generate AML. An AML interpreter author must understand how to execute AML.

AML and ASL are different languages, though they are closely related.

All ACPI-compatible operating systems must support AML. A given user can define some arbitrary source language (to replace ASL) and write a tool to translate it to AML. However, the ACPI group will support a single translator for a single language, ASL.

20.1 Notation Conventions

The notation conventions in the table below help the reader to interpret the AML formal grammar.

Table 20.1: AML Grammar Notation Conventions

Notation Convention	Description	Example
0xdd	Refers to a byte value expressed as 2 hexadecimal digits.	0x21
Number in bold.	Denotes the encoding of the AML term.	
Term => Evaluated Type	Shows the resulting type of the evaluation of Term.	
Single quotes (' ')	Indicate constant characters.	'A' => 0x41
Term := Term Term ...	The term to the left of := can be expanded into the sequence of terms on the right.	aterm := bterm cterm means that aterm can be expanded into the two-term sequence of bterm followed by cterm.

continues on next page

Table 20.1 – continued from previous page

Notation Convention	Description	Example
Term Term Term ...	Terms separated from each other by spaces form an ordered list.	
Angle brackets (<>)	used to group items.	<a b> <c d> means either a b or c d.
Bar symbol ()	Separates alternatives.	aterm := bterm [cterm dterm] means the following constructs are possible: bterm cterm dterm aterm := [bterm cterm] dterm means the following constructs are possible: bterm dterm cterm dterm
Dash character (-)	Indicates a range.	1-9 means a single digit in the range 1 to 9 inclusive.
Parenthesized term following another term.	The parenthesized term is the repeat count of the previous term.	aterm(3) means aterm aterm aterm. bterm(n) means n number of bterms.

20.2 AML Grammar Definition

This section defines the byte values that make up an AML byte stream.

The AML encoding can be categorized into the following groups:

- Table and Table Header encoding
- Name objects encoding
- Data objects encoding
- Package length encoding
- Term objects encoding
- Miscellaneous objects encoding

20.2.1 Table and Table Header Encoding

AMLCode := *DefBlockHeader TermList*

DefBlockHeader := *TableSignature TableLength SpecCompliance CheckSum OemID OemTableID OemRevision CreatorID CreatorRevision*

TableSignature := *DWordData* // As defined in section 5.2.3.

TableLength := *DWordData* // Length of the table in bytes including the block header.

SpecCompliance := *ByteData* // The revision of the structure.

CheckSum := *ByteData* // Byte checksum of the entire table.

OemID :=

ByteData(6) // OEM ID of up to 6 characters. If the OEM ID is shorter than 6 characters, it can be terminated with a NULL character.

OemTableID :=

ByteData(8) // OEM Table ID of up to 8 characters. If the OEM Table ID is shorter than 8 characters,
it can be terminated with a NULL character.

OemRevision := DWordData // OEM Table Revision.

CreatorID := DWordData // Vendor ID of the ASL compiler.

CreatorRevision := DWordData // Revision of the ASL compiler.

20.2.2 Name Objects Encoding

LeadNameChar := 'A'-'Z' | '_'

DigitChar := '0' - '9'

NameChar := *DigitChar* | *LeadNameChar*

RootChar := '^'

ParentPrefixChar := '^'

'A'-'Z' := 0x41 - 0x5A

'_' := 0x5F

'0'-'9' := 0x30 - 0x39

'^' := 0x5C

'^' := 0x5E

NameSeg :=

<leadnamechar namechar namechar namechar>

// Notice that NameSegs shorter than 4 characters are filled with trailing underscores ('_'s).

NameString := *<rootchar namepath>* | *<prefixpath namepath>*

PrefixPath := Nothing | *<'^' prefixpath>*

NamePath := NameSeg | *DualNamePath* | *MultiNamePath* | *NullName*

DualNamePath := *DualNamePrefix NameSeg NameSeg*

DualNamePrefix := 0x2E

MultiNamePath := *MultiNamePrefix SegCount NameSeg(SegCount)*

MultiNamePrefix := 0x2F

SegCount := **ByteData**

// SegCount can be from 1 to 255. For example: MultiNamePrefix(35) is

// encoded as 0x2f 0x23 and followed by 35 NameSegs. So, the total

// encoding length will be 1 + 1 + 35*4 = 142. Notice that:

// DualNamePrefix NameSeg NameSeg has a smaller encoding than the

// encoding of: MultiNamePrefix(2) NameSeg NameSeg

SimpleName := *NameString* | *ArgObj* | *LocalObj*

SuperName := *SimpleName* | *DebugObj* | *ReferenceTypeOpcode*

NullName := 0x00

Target := *SuperName* | *NullName*

20.2.3 Data Objects Encoding

ComputationalData := *ByteConst* | *WordConst* | *DWordConst* | *QWordConst* | *String* | *ConstObj* | *RevisionOp* | *DefBuffer*

DataObject := *ComputationalData* | *DefPackage* | *DefVarPackage*

DataRefObject := *DataObject* | *ObjectReference*

ByteConst := *BytePrefix* *ByteData*

BytePrefix := 0x0A

WordConst := *WordPrefix* *WordData*

WordPrefix := 0x0B

DWordConst := *DWordPrefix* *DWordData*

DWordPrefix := 0x0C

QWordConst := *QWordPrefix* *QWordData*

QWordPrefix := 0x0E

String := *StringPrefix* *AsciiCharList* *NullChar*

StringPrefix := 0x0D

ConstObj := *ZeroOp* | *OneOp* | *OnesOp*

ByteList := *Nothing* | *<bytedata bytelist>*

ByteData := 0x00 - 0xFF

***WordData* := *ByteData*[0:7] *ByteData*[8:15] // 0x0000-0xFFFF**

***DWordData* := *WordData*[0:15] *WordData*[16:31] // 0x00000000-0xFFFFFFFF**

***QWordData* := *DWordData*[0:31] *DWordData*[32:63] // 0x0000000000000000-0xFFFFFFFFFFFFFFFF**

AsciiCharList := *Nothing* | *<asciichar asciicharlist>*

AsciiChar := 0x01 - 0x7F

NullChar := 0x00

ZeroOp := 0x00

OneOp := 0x01

OnesOp := 0xFF

RevisionOp := *ExtOpPrefix* 0x30

ExtOpPrefix := 0x5B

20.2.4 Package Length Encoding

PkgLength :=

PkgLeadByte |
 <*pkgleadbyte bytedata*> |
 <*pkgleadbyte bytedata bytedata*> |
 <*pkgleadbyte bytedata bytedata bytedata*>

PkgLeadByte :=

<bit 7-6: bytedata count that follows (0-3)>
 <bit 5-4: only used if pkglength < 63>
 <bit 3-0: least significant package length nybble>

Note: The high 2 bits of the first byte reveal how many follow bytes are in the PkgLength. If the PkgLength has only one byte, bit 0 through 5 are used to encode the package length (in other words, values 0-63). If the package length value is more than 63, more than one byte must be used for the encoding in which case bit 4 and 5 of the PkgLeadByte are reserved and must be zero. If the multiple bytes encoding is used, bits 0-3 of the PkgLeadByte become the least significant 4 bits of the resulting package length value. The next ByteData will become the next least significant 8 bits of the resulting value and so on, up to 3 ByteData bytes. Thus, the maximum package length is 2*28.

20.2.5 Term Objects Encoding

Object := *NamespaceModifierObj* | *NamedObj*

TermObj := *Object* | *StatementOpcode* | *ExpressionOpcode*

TermList := Nothing | <*termobj termlist*>

TermArg := *ExpressionOpcode* | *DataObject* | *ArgObj* | *LocalObj*

MethodInvocation := *NameString TermArgList*

TermArgList := Nothing | <*termarg termarglist*>

20.2.5.1 Namespace Modifier Objects Encoding

NamespaceModifierObj := *DefAlias* | *DefName* | *DefScope*

DefAlias := *AliasOp NameString NameString*

AliasOp := 0x06

DefName := *NameOp NameString DataRefObject*

NameOp := 0x08

DefScope := *ScopeOp PkgLength NameString TermList*

ScopeOp := 0x10

20.2.5.2 Named Objects Encoding

NamedObj := *DefBankField* | *DefCreateBitField* | *DefCreateByteField* | *DefCreateDWordField* | *DefCreateField* | *DefCreateQWordField* | *DefCreateWordField* | *DefDataRegion* | *DefExternal* | *DefOpRegion* | *DefPowerRes* | *DefThermalZone*

DefBankField := *BankFieldOp* *PkgLength* *NameString* *NameString* *BankValue* *FieldFlags* *FieldList*

BankFieldOp := *ExtOpPrefix* 0x87

BankValue := *TermArg* => Integer

FieldFlags :=

ByteData // bit 0-3: AccessType

// 0 AnyAcc

// 1 ByteAcc

// 2 WordAcc

// 3 DWordAcc

// 4 QWordAcc

// 5 BufferAcc

// 6 Reserved

// 7-15 Reserved

// bit 4: LockRule

// 0 NoLock

// 1 Lock

// bit 5-6: UpdateRule

// 0 Preserve

// 1 WriteAsOnes

// 2 WriteAsZeros

// bit 7: Reserved (must be 0)

FieldList := Nothing | <*fieldelement fieldlist*>

NamedField := *NameSeg* *PkgLength*

ReservedField := 0x00 *PkgLength*

AccessField := 0x01 *AccessType* *AccessAttrib*

AccessType :=

ByteData // Bits 0:3 - Same as AccessType bits of FieldFlags.

// Bits 4:5 - Reserved

// Bits 7:6 - 0 = AccessAttrib = Normal Access Attributes

// 1 = AccessAttrib = AttribBytes (x)

// 2 = AccessAttrib = AttribRawBytes (x)

// 3 = AccessAttrib = AttribRawProcessBytes (x)

//

// x' is encoded as bits 0:7 of the AccessAttrib byte.

AccessAttrib :=

ByteData // If AccessType is BufferAcc for the SMB or

// GPIO OpRegions, AccessAttrib can be one of

// the following values:

```

// 0x02 AttribQuick
// 0x04 AttribSendReceive
// 0x06 AttribByte
// 0x08 AttribWord
// 0x0A AttribBlock
// 0x0C Attrib ProcessCall
// 0x0D AttribBlockProcessCall

ConnectField := <0x02 NameString> | <0x02 BufferData>

DefCreateBitField := CreateBitFieldOp SourceBuff BitIndex NameString
CreateBitFieldOp := 0x8D

SourceBuff := TermArg => Buffer

BitIndex := TermArg => Integer

DefCreateByteField := CreateByteFieldOp SourceBuff ByteIndex NameString
CreateByteFieldOp := 0x8C

ByteIndex := TermArg => Integer

DefCreateDWordField := CreateDWordFieldOp SourceBuff ByteIndex NameString
CreateDWordFieldOp := 0x8A

DefCreateField := CreateFieldOp SourceBuff BitIndex NumBits NameString
CreateFieldOp := ExtOpPrefix 0x13

NumBits := TermArg => Integer

DefCreateQWordField := CreateQWordFieldOp SourceBuff ByteIndex NameString
CreateQWordFieldOp := 0x8F

DefCreateWordField := CreateWordFieldOp SourceBuff ByteIndex NameString
CreateWordFieldOp := 0x8B

DefDataRegion := DataRegionOp NameString TermArg TermArg TermArg
DataRegionOp := ExOpPrefix 0x88

DefDevice := DeviceOp PkgLength NameString TermList
DeviceOp := ExtOpPrefix 0x82

DefEvent := EventOp NameString
EventOp := ExtOpPrefix 0x02

DefExternal := ExternalOp NameString ObjectType ArgumentCount
ExternalOp := 0x15

ObjectType := ByteData
ArgumentCount := ByteData (0 - 7)

DefField := FieldOp PkgLength NameString FieldFlags FieldList
FieldOp := ExtOpPrefix 0x81

DefIndexField := IndexFieldOp PkgLength NameString NameString FieldFlags FieldList

```

```

IndexFieldOp := ExtOpPrefix 0x86
DefMethod := MethodOp PkgLength NameString MethodFlags TermList
MethodOp := 0x14
MethodFlags :=
    ByteData // bit 0-2: ArgCount (0-7)
    // bit 3: SerializeFlag
    // 0 NotSerialized
    // 1 Serialized
    // bit 4-7: SyncLevel (0x00-0x0f)
DefMutex := MutexOp NameString SyncFlags
MutexOp := ExtOpPrefix 0x01
SyncFlags := ByteData // bits 0-3: SyncLevel (0x00-0x0f), bits 4-7: Reserved (must be 0)
DefOpRegion := OpRegionOp NameString RegionSpace RegionOffset RegionLen
OpRegionOp := ExtOpPrefix 0x80
RegionSpace :=
    ByteData // 0x00 SystemMemory
    // 0x01 SystemIO
    // 0x02 PCI_Config
    // 0x03 EmbeddedControl
    // 0x04 SMBus
    // 0x05 System CMOS
    // 0x06 PciBarTarget
    // 0x07 IPMI
    // 0x08 GeneralPurposeIO
    // 0x09 GenericSerialBus
    // 0x0A PCC
    // 0x80-0xFF: OEM Defined
RegionOffset := TermArg => Integer
RegionLen := TermArg => Integer
DefPowerRes := PowerResOp PkgLength NameString SystemLevel ResourceOrder TermList
PowerResOp := ExtOpPrefix 0x84
SystemLevel := ByteData
ResourceOrder := WordData
ProcID := ByteData
PblkAddr := DWordData
PblkLen := ByteData
DefThermalZone := ThermalZoneOp PkgLength NameString TermList
ThermalZoneOp := ExtOpPrefix 0x85
ExtendedAccessField := 0x03 AccessType ExtendedAccessAttrib AccessLength

```

ExtendedAccessAttrib := ByteData // 0x0B AttribBytes, 0x0E AttribRawBytes, 0x0F AttribRawProcess

FieldElement := *NamedField* | *ReservedField* | *AccessField* | *ExtendedAccessField* | *ConnectField*

20.2.5.3 Statement Opcodes Encoding

StatementOpcode := *DefBreak* | *DefBreakPoint* | *DefContinue* | *DefFatal* | *DefIfElse* | *DefNoop* | *DefNotify* | *DefRelease* | *DefReset* | *DefReturn* | *DefSignal* | *DefSleep* | *DefStall* | *DefWhile*

DefBreak := *BreakOp*

BreakOp := 0xA5

DefBreakPoint := *BreakPointOp*

BreakPointOp := 0xCC

DefContinue := *ContinueOp*

ContinueOp := 0x9F

DefElse := Nothing | *<elseop pkglength termlist>*

ElseOp := 0xA1

DefFatal := *FatalOp FatalType FatalCode FatalArg*

FatalOp := *ExtOpPrefix* 0x32

FatalType := *ByteData*

FatalCode := *DWordData*

FatalArg := *TermArg* => Integer

DefIfElse := *IfOp PkgLength Predicate TermList DefElse*

IfOp := 0xA0

Predicate := *TermArg* => Integer

DefNoop := *NoopOp*

NoopOp := 0xA3

DefNotify := *NotifyOp NotifyObject NotifyValue*

NotifyOp := 0x86

NotifyObject := *SuperName* => ThermalZone | Processor | Device

NotifyValue := *TermArg* => Integer

DefRelease := *ReleaseOp MutexObject*

ReleaseOp := *ExtOpPrefix* 0x27

MutexObject := *SuperName*

DefReset := *ResetOp EventObject*

ResetOp := *ExtOpPrefix* 0x26

EventObject := *SuperName*

DefReturn := *ReturnOp ArgObject*

ReturnOp := 0xA4

ArgObject := *TermArg* => *DataRefObject*
 DefSignal := *SignalOp EventObject*
 SignalOp := *ExtOpPrefix* 0x24
 DefSleep := *SleepOp MsecTime*
 SleepOp := *ExtOpPrefix* 0x22
 MsecTime := *TermArg* => *Integer*
 DefStall := *StallOp UsecTime*
 StallOp := *ExtOpPrefix* 0x21
 UsecTime := *TermArg* => *ByteData*
 DefWhile := *WhileOp PkgLength Predicate TermList*
 WhileOp := 0xA2

20.2.5.4 Expression Opcodes Encoding

ExpressionOpcode := *DefAcquire* | *DefAdd* | *DefAnd* | *DefBuffer* | *DefConcat* | *DefConcatRes* | *DefCondRefOf* | *DefCopyObject* | *DefDecrement* | *DefDerefOf* | *DefDivide* | *DefFindSetLeftBit* | *DefFindSetRightBit* | *DefFromBCD* | *DefIncrement* | *DefIndex* | *DefLAnd* | *DefLEqual* | *DefLGreater* | *DefLGreaterEqual* | *DefLLess* | *DefLLessEqual* | *DefMid* | *DefLNot* | *DefLNotEqual* | *DefLoadTable* | *DefLOR* | *DefMatch* | *DefMod* | *DefMultiply* | *DefNAnd* | *DefNOR* | *DefNot* | *DefObjectType* | *DefOr* | *DefPackage* | *DefVarPackage* | *DefRefOf* | *DefShiftLeft* | *DefShiftRight* | *DefSizeOf* | *DefStore* | *DefSubtract* | *DefTimer* | *DefToBCD* | *DefToBuffer* | *DefToDecimalString* | *DefToHexString* | *DefToInteger* | *DefToString* | *DefWait* | *DefXOR* | *MethodInvocation*

ReferenceTypeOpcode := *DefRefOf* | *DefDerefOf* | *DefIndex* | *UserTermObj*

DefAcquire := *AcquireOp MutexObject Timeout*
 AcquireOp := *ExtOpPrefix* 0x23
 Timeout := *WordData*
 DefAdd := *AddOp Operand Operand Target*
 AddOp := 0x72
 Operand := *TermArg* => *Integer*
 DefAnd := *AndOp Operand Operand Target*
 AndOp := 0x7B
 DefBuffer := *BufferOp PkgLength BufferSize ByteList*
 BufferOp := 0x11
 BufferSize := *TermArg* => *Integer*
 DefConcat := *ConcatOp Data Data Target*
 ConcatOp := 0x73
 Data := *TermArg* => *ComputationalData*
 DefConcatRes := *ConcatResOp BufData BufData Target*
 ConcatResOp := 0x84

BufData := TermArg => Buffer
DefCondRefOf := CondRefOfOp SuperName Target
CondRefOfOp := ExtOpPrefix 0x12
DefCopyObject := CopyObjectOp TermArg SimpleName
CopyObjectOp := 0x9D
DefDecrement := DecrementOp SuperName
DecrementOp := 0x76
DefDerefOf := DerefOfOp ObjReference
DerefOfOp := 0x83
ObjReference := TermArg => ObjectReference | String
DefDivide := DivideOp Dividend Divisor Remainder Quotient
DivideOp := 0x78
Dividend := TermArg => Integer
Divisor := TermArg => Integer
Remainder := Target
Quotient := Target
DefFindSetLeftBit := FindSetLeftBitOp Operand Target
FindSetLeftBitOp := 0x81
DefFindSetRightBit := FindSetRightBitOp Operand Target
FindSetRightBitOp := 0x82
DefFromBCD := FromBCDOp BCDValue Target
FromBCDOp := ExtOpPrefix 0x28
BCDValue := TermArg => Integer
DefIncrement := IncrementOp SuperName
IncrementOp := 0x75
DefIndex := IndexOp BuffPkgStrObj IndexValue Target
IndexOp := 0x88
BuffPkgStrObj := TermArg => Buffer, Package, or String
IndexValue := TermArg => Integer
DefLAnd := LandOp Operand Operand
LandOp := 0x90
DefLEqual := LequalOp Operand Operand
LequalOp := 0x93
DefLGreater := LgreaterOp Operand Operand
LgreaterOp := 0x94
DefLGreaterEqual := LgreaterEqualOp Operand Operand

LgreaterEqualOp := LnotOp LlessOp
DefLLess := LlessOp Operand Operand
LlessOp := 0x95
DefLLessEqual := LlessEqualOp Operand Operand
LlessEqualOp := LnotOp LgreaterOp
DefLNot := LnotOp Operand
LnotOp := 0x92
DefLNotEqual := LnotEqualOp Operand Operand
LnotEqualOp := LnotOp LequalOp
DefLoad := LoadOp NameString Target
LoadOp := ExtOpPrefix 0x20
DefLoadTable := LoadTableOp TermArg TermArg TermArg TermArg TermArg TermArg
LoadTableOp := ExtOpPrefix 0x1F
DefLor := LorOp Operand Operand
LorOp := 0x91
DefMatch := MatchOp SearchPkg MatchOpcode Operand MatchOpcode Operand StartIndex
MatchOp := 0x89
SearchPkg := TermArg => Package
MatchOpcode :=
 ByteData // 0 MTR
 // 1 MEQ
 // 2 MLE
 // 3 MLT
 // 4 MGE
 // 5 MGT
StartIndex := TermArg => Integer
DefMid := MidOp MidObj TermArg TermArg Target
MidOp := 0x9E
MidObj := TermArg => Buffer | String
DefMod := ModOp Dividend Divisor Target
ModOp := 0x85
DefMultiply := MultiplyOp Operand Operand Target
MultiplyOp := 0x77
DefNand := NandOp Operand Operand Target
NandOp := 0x7C
DefNor := NorOp Operand Operand Target
NorOp := 0x7E

DefNot := *NotOp Operand Target*
 NotOp := 0x80
 DefObjectType := *ObjectTypeOp <SimpleName | DebugObj | DefRefOf | DefDerefOf | DefIndex>*
 ObjectTypeOp := 0x8E
 DefOr := *OrOp Operand Operand Target*
 OrOp := 0x7D
 DefPackage := *PackageOp PkgLength NumElements PackageElementList*
 PackageOp := 0x12
 DefVarPackage := *VarPackageOp PkgLength VarNumElements PackageElementList*
 VarPackageOp := 0x13
 NumElements := *ByteData*
 VarNumElements := *TermArg => Integer*
 PackageElementList := *Nothing | <packageelement packageelementlist>*
 PackageElement := *DataRefObject | NameString*
 DefRefOf := *RefOfOp SuperName*
 RefOfOp := 0x71
 DefShiftLeft := *ShiftLeftOp Operand ShiftCount Target*
 ShiftLeftOp := 0x79
 ShiftCount := *TermArg => Integer*
 DefShiftRight := *ShiftRightOp Operand ShiftCount Target*
 ShiftRightOp := 0x7A
 DefSizeOf := *SizeOfOp SuperName*
 SizeOfOp := 0x87
 DefStore := *StoreOp TermArg SuperName*
 StoreOp := 0x70
 DefSubtract := *SubtractOp Operand Operand Target*
 SubtractOp := 0x74
 DefTimer := *TimerOp*
 TimerOp := 0x5B 0x33
 DefToBCD := *ToBCDOp Operand Target*
 ToBCDOp := *ExtOpPrefix 0x29*
 DefToBuffer := *ToBufferOp Operand Target*
 ToBufferOp := 0x96
 DefToDecimalString := *ToDecimalStringOp Operand Target*
 ToDecimalStringOp := 0x97
 DefToHexString := *ToHexStringOp Operand Target*

ToHexStringOp := 0x98
 DefToInteger := *ToIntegerOp Operand Target*
 ToIntegerOp := 0x99
 DefToString := *ToStringOp TermArg LengthArg Target*
 LengthArg := *TermArg => Integer*
 ToStringOp := 0x9C
 DefWait := *WaitOp EventObject Operand*
 WaitOp := *ExtOpPrefix* 0x25
 DefXOr := *XorOp Operand Operand Target*
 XorOp := 0x7F

20.2.6 Miscellaneous Objects Encoding

Miscellaneous objects include:

- Arg objects
- Local objects
- Debug objects

20.2.6.1 Arg Objects Encoding

ArgObj := Arg0Op | Arg1Op | Arg2Op | Arg3Op | Arg4Op | Arg5Op | Arg6Op
 Arg0Op := 0x68
 Arg1Op := 0x69
 Arg2Op := 0x6A
 Arg3Op := 0x6B
 Arg4Op := 0x6C
 Arg5Op := 0x6D
 Arg6Op := 0x6E

20.2.6.2 Local Objects Encoding

LocalObj := Local0Op | Local1Op | Local2Op | Local3Op | Local4Op | Local5Op | Local6Op | Local7Op
 Local0Op := 0x60
 Local1Op := 0x61
 Local2Op := 0x62
 Local3Op := 0x63
 Local4Op := 0x64
 Local5Op := 0x65
 Local6Op := 0x66

Local7Op := 0x67

20.2.6.3 Debug Objects Encoding

DebugObj := *DebugOp*

DebugOp := *ExtOpPrefix* 0x31

20.3 AML Byte Stream Byte Values

The following table lists all byte values that can be found in an AML byte stream, and the meaning of each byte value. This table is useful for debugging AML code.

Table 20.2: AML Byte Stream Byte Values

Encoding Value	Encoding Name	Encoding Group	Fixed List Arguments	Variable List Arguments
0x00	ZeroOp	Data Object	—	—
0x01	OneOp	Data Object	—	—
0x02-0x05	—	—	—	—
0x06	AliasOp	Term Object	NameString NameString	—
0x07	—	—	—	—
0x08	NameOp	Term Object	NameString DataRefObject	—
0x09	—	—	—	—
0x0A	BytePrefix	Data Object	ByteData	—
0x0B	WordPrefix	Data Object	WordData	—
0x0C	DWordPrefix	Data Object	DWordData	—
0x0D	StringPrefix	Data Object	AsciiCharList NullChar	—
0x0E	QWordPrefix	Data Object	QWordData	—
0x0F	—	—	—	—
0x10	ScopeOp	Term Object	NameString	TermList
0x11	BufferOp	Term Object	TermArg	ByteList
0x12	PackageOp	Term Object	ByteData	Package TermList
0x13	VarPackageOp	Term Object	TermArg	Package TermList
0x14	MethodOp	Term Object	NameString ByteData	TermList
0x15	ExternalOp	Name Object	NameString ByteData ByteData	—
0x16-0x2D	—	—	—	—
0x2E (‘.’)	DualNamePrefix	Name Object	NameSeg NameSeg	—
0x2F (‘/’)	MultiNamePrefix	Name Object	ByteData NameSeg(N)	—
0x30-0x39 (‘0’-‘9’)	DigitChar	Name Object	—	—
0x3A-0x40	—	—	—	—
0x41-0x5A (‘A’-‘Z’)	NameChar	Name Object	—	—
0x5B (‘[’)	ExtOpPrefix	—	ByteData	—
0x5B 0x00	—	—	—	—
0x5B 0x01	MutexOp	Term Object	NameString ByteData	—
0x5B 0x02	EventOp	Term Object	NameString	—

continues on next page

Table 20.2 – continued from previous page

Encoding Value	Encoding Name	Encoding Group	Fixed List Arguments	Variable List Arguments
0x5B 0x12	CondRefOfOp	Term Object	SuperName SuperName	—
0x5B 0x13	CreateFieldOp	Term Object	TermArg TermArg TermArg NameString	—
0x5B 0x1F	LoadTableOp	Term Object	TermArg TermArg TermArg TermArg TermArg TermArg	—
0x5B 0x20	LoadOp	Term Object	NameString SuperName	—
0x5B 0x21	StallOp	Term Object	TermArg	—
0x5B 0x22	SleepOp	Term Object	TermArg	—
0x5B 0x23	AcquireOp	Term Object	SuperName WordData	—
0x5B 0x24	SignalOp	Term Object	SuperName	—
0x5B 0x25	WaitOp	Term Object	SuperName TermArg	—
0x5B 0x26	ResetOp	Term Object	SuperName	—
0x5B 0x27	ReleaseOp	Term Object	SuperName	—
0x5B 0x28	FromBCDOp	Term Object	TermArg Target	—
0x5B 0x29	ToBCD	Term Object	TermArg Target	—
0x5B 0x2A	Reserved	—	—	—
0x5B 0x30	RevisionOp	Data Object	—	—
0x5B 0x31	DebugOp	Debug Object	—	—
0x5B 0x32	FatalOp	Term Object	ByteData DWordData TermArg	—
0x5B 0x33	TimerOp	Term Object	—	—
0x5B 0x80	OpRegionOp	Term Object	NameString ByteData TermArg TermArg	—
0x5B 0x81	FieldOp	Term Object	NameString ByteData	FieldList
0x5B 0x82	DeviceOp	Term Object	NameString	TermList
0x5B 0x83	<i>Permanently Reserved</i>	—	Use of this opcode for ProcessorOp was deprecated in ACPI 6.4, and is not to be reused.	—
0x5B 0x84	PowerResOp	Term Object	NameString ByteData WordData	TermList
0x5B 0x85	ThermalZoneOp	Term Object	NameString	TermList
0x5B 0x86	IndexFieldOp	Term Object	NameString NameString ByteData	FieldList
0x5B 0x87	BankFieldOp	Term Object	NameString NameString TermArg ByteData	FieldList
0x5B 0x88	DataRegionOp	Term Object	NameString TermArg TermArg TermArg	—
0x5B 0x80 - 0x5B 0xFF	—	—	—	—
0x5C ('\')	RootChar	Name Object	—	—
0x5D	—	—	—	—
0x5E (^)	ParentPrefixChar	Name Object	—	—
0x5F('_')	NameChar—	Name Object	—	—
0x60 (``)	Local0Op	Local Object	—	—
0x61 (‘a’)	Local1Op	Local Object	—	—
0x62 (‘b’)	Local2Op	Local Object	—	—
0x63 (‘c’)	Local3Op	Local Object	—	—
0x64 (‘d’)	Local4Op	Local Object	—	—
0x65 (‘e’)	Local5Op	Local Object	—	—

continues on next page

Table 20.2 – continued from previous page

Encoding Value	Encoding Name	Encoding Group	Fixed List Arguments	Variable List Arguments
0x66 ('f')	Local6Op	Local Object	—	—
0x67 ('g')	Local7Op	Local Object	—	—
0x68 ('h')	Arg0Op	Arg Object	—	—
0x69 ('i')	Arg1Op	Arg Object	—	—
0x6A ('j')	Arg2Op	Arg Object	—	—
0x6B ('k')	Arg3Op	Arg Object	—	—
0x6C ('l')	Arg4Op	Arg Object	—	—
0x6D ('m')	Arg5Op	Arg Object	—	—
0x6E ('n')	Arg6Op	Arg Object	—	—
0x6F	—	—	—	—
0x70	StoreOp	Term Object	TermArg SuperName	—
0x71	RefOfOp	Term Object	SuperName	—
0x72	AddOp	Term Object	TermArg TermArg Target	—
0x73	ConcatOp	Term Object	TermArg TermArg Target	—
0x74	SubtractOp	Term Object	TermArg TermArg Target	—
0x75	IncrementOp	Term Object	SuperName	—
0x76	DecrementOp	Term Object	SuperName	—
0x77	MultiplyOp	Term Object	TermArg TermArg Target	—
0x78	DivideOp	Term Object	TermArg TermArg Target Target	—
0x79	ShiftLeftOp	Term Object	TermArg TermArg Target	—
0x7A	ShiftRightOp	Term Object	TermArg TermArg Target	—
0x7B	AndOp	Term Object	TermArg TermArg Target	—
0x7C	NandOp	Term Object	TermArg TermArg Target	—
0x7D	OrOp	Term Object	TermArg TermArg Target	—
0x7E	NorOp	Term Object	TermArg TermArg Target	—
0x7F	XorOp	Term Object	TermArg TermArg Target	—
0x80	NotOp	Term Object	TermArg Target	—
0x81	FindSetLeftBitOp	Term Object	TermArg Target	—
0x82	FindSetRightBitOp	Term Object	TermArg Target	—
0x83	DerefOfOp	Term Object	TermArg	—
0x84	ConcatResOp	Term Object	TermArg TermArg Target	—
0x85	ModOp	Term Object	TermArg TermArg Target	—
0x86	NotifyOp	Term Object	SuperName TermArg	—
0x87	SizeOfOp	Term Object	SuperName	—
0x88	IndexOp	Term Object	TermArg TermArg Target	—
0x89	MatchOp	Term Object	TermArg ByteData TermArg ByteData TermArg TermArg	—
0x8A	CreateDWordFieldOp	Term Object	TermArg TermArg NameString	—
0x8B	CreateWordFieldOp	Term Object	TermArg TermArg NameString	—
0x8C	CreateByteFieldOp	Term Object	TermArg TermArg NameString	—
0x8D	CreateBitFieldOp	Term Object	TermArg TermArg NameString	—
0x8E	ObjectTypeOp	Term Object	SuperName	—
0x8F	CreateQWordFieldOp	Term Object	TermArg TermArg NameString	—
0x90	LandOp	Term Object	TermArg TermArg	—
0x91	LorOp	Term Object	TermArg TermArg	—
0x92	LnotOp	Term Object	TermArg	—

continues on next page

Table 20.2 – continued from previous page

Encoding Value	Encoding Name	Encoding Group	Fixed List Arguments	Variable List Arguments
0x92 0x93	LNotEqualOp	Term Object	TermArg TermArg	—
0x92 0x94	LLessEqualOp	Term Object	TermArg TermArg	—
0x92 0x95	LGreaterEqualOp	Term Object	TermArg TermArg	—
0x93	LEqualOp	Term Object	TermArg TermArg	—
0x94	LGreaterOp	Term Object	TermArg TermArg	—
0x95	LLessOp	Term Object	TermArg TermArg	—
0x96	ToBufferOp	Term Object	TermArg Target	—
0x97	ToDecimalStringOp	Term Object	TermArg Target	—
0x98	ToHexStringOp	Term Object	TermArg Target	—
0x99	ToIntegerOp	Term Object	TermArg Target	—
0x9A-0x9B	—	—	—	—
0x9C	ToStringOp	Term Object	TermArg TermArg Target	—
0x9D	CopyObjectOp	Term Object	TermArg SimpleName	—
0x9E	MidOp	Term Object	TermArg TermArg TermArg Target	—
0x9F	ContinueOp	Term Object	—	—
0xA0	IfOp	Term Object	TermArg	TermList
0xA1	ElseOp	Term Object	—	TermList
0xA2	WhileOp	Term Object	TermArg	TermList
0xA3	NoopOp	Term Object	—	—
0xA4	ReturnOp	Term Object	TermArg	—
0xA5	BreakOp	Term Object	—	—
0xA6-0xCB	—	—	—	—
0xCC	BreakPointOp	Term Object	—	—
0xCD-0xFE	—	—	—	—
0xFF	OnesOp	Data Object	—	—

20.4 AML Encoding of Names in the Namespace

Assume the following namespace exists:

```

\\
S0
  MEM
    SET
    GET
S1
  MEM
    SET
    GET
  CPU
    SET
    GET

```

Assume further that a definition block is loaded that creates a node `\\S0.CPU.SET`, and loads a block using it as a root. Assume the loaded block contains the following names:

```

STP1
^GET
^^PCI0
^^PCI0.SBS
\\S2
\\S2.ISA.COM1
^^^S3
^^^S2.MEM
^^^S2.MEM.SET
Scope (\S0.CPU.SET.STP1) {
    XYZ
    ^ABC
    ^ABC.DEF
}

```

This will be encoded in AML as:

```

'STP1'
ParentPrefixChar 'GET_'
ParentPrefixChar ParentPrefixChar 'PCI0'
ParentPrefixChar ParentPrefixChar DualNamePrefix 'PCI0' 'SBS_'
RootChar 'S2__'
RootChar MultiNamePrefix 3 'S2__' 'ISA_' 'COM1'
ParentPrefixChar ParentPrefixChar ParentPrefixChar 'S3__'
ParentPrefixChar ParentPrefixChar ParentPrefixChar DualNamePrefix 'S2__' 'MEM_'
ParentPrefixChar ParentPrefixChar ParentPrefixChar MultiNamePrefix 3 'S2__' 'MEM_'
↪ 'SET_'

```

After the block is loaded, the namespace will look like this (names added to the namespace by the loading operation are shown in bold):

```

\\
  S0
    MEM
      SET
      GET
    CPU
      SET
        STP1
          XYZ
          ABC
          DEF
        GET
      PCI0
      SBS
  S1
    MEM
      SET
      GET
    CPU
      SET
      GET
  S2
    ISA
      COM1
    MEM
      SET
  S3

```

ACPI DATA TABLES AND TABLE DEFINITION LANGUAGE

There are two fundamental types of ACPI tables:

- Tables that contain AML code produced from the ACPI Source Language (ASL). These include the DSDT, any SSDTs, and sometimes OEM-specific tables (OEMx).
- Tables that contain simple data and no AML byte code. These types of tables are known as ACPI Data Tables. They include tables such as the FADT, MADT, ECDDT, SRAT, etc. - essentially any table other than a DSDT or SSDT.
- The first type of table is generated using an ASL compiler and this language is specified in section 18.

The second type of table, the ACPI Data Table, is addressed by this section.

This section describes a simple language (the Table Definition Language or TDL) that can be used to generate any ACPI data table. It simplifies the table generation for platform firmware vendors and can automatically generate fields such as table lengths, subtable lengths, checksums, flag fields, etc.

21.1 Types of ACPI Data Tables

In the context of a compiler for the Table Definition Language (TDL), there are two types of ACPI Data Tables:

- ACPI tables that are “known” to the compiler. These would typically include all of the basic ACPI tables defined in the ACPI specification such as the FADT, MADT, ECDDT, etc. Since these tables are fully specified (usually via the ACPI specification, but from other sources as well), the TDL compiler knows all details of these tables – including all required data types, optional or required sub-tables, etc.
- ACPI tables that are unknown to the compiler. These may include tables that are not defined in the ACPI specification such as MCFG, DBGP, etc., or simply new ACPI tables that have not yet been implemented in the compiler.

One of the goals of the ACPI Table Definition Language is to support both cases above. Most ACPI tables will be known to the compiler (and will be the easiest to specify in TDL), but the language is general enough to allow the definition of new ACPI tables that are unknown or unimplemented in the compiler.

An additional goal of TDL is to support the output of a disassembler that formats an existing table into TDL. This enables disassembler/change/compile operations.

21.2 ACPI Table Definition Language Specification

The following section defines the ACPI Table Definition Language (TDL). The grammar notation follows the same rules as the ASL source language (See [Section 19.2.1](#)). Full definition of the various data types follows the ASL grammar specification.

21.2.1 Overview of the Table Definition Language (TDL)

Most ACPI tables share the following structure (all except FACS):

- A common, 36 byte header containing the table signature, length, checksum, revision, and other data.
- A table body which contains the specific table data.

The Table Definition Language allows the definition of an ACPI table via a collection of fields. Each line of TDL source code is a field, and corresponds to a single data item in the definition of the table.

For example, the C definition of the common ACPI table header is as follows:

```
typedef struct acpi_table_header
{
    char Signature[4];
    UINT32 Length;
    UINT8 Revision;
    UINT8 Checksum;
    char OemId[6];
    char OemTableId[8];
    UINT32 OemRevision;
    char AslCompilerId[4];
    UINT32 AslCompilerRevision;
} ACPI_TABLE_HEADER;
```

In the Table Definition Language, an ACPI table header can be described as follows:

```
: "ECDT"
: 00000000
: 01
: 00
: "OEM "
: "MACHINE1"
: 00000001
: ""
: 00000000
```

Additionally and optionally, it can also be described with accompanying field names:

```
Signature : "ECDT" [Embedded Controller Boot Resources Table]
Table Length : 00000000
Revision : 01
Checksum : 00
Oem ID : "OEM "
Oem Table ID : "MACHINE1"
Oem Revision : 00000001
Asl Compiler ID : ""
Asl Compiler Revision : 00000000
```

Note: In the ACPI table header, the TableLength, Checksum, AslCompilerId, and the AslCompilerRevision fields are all output fields that are filled in automatically by the compiler during table generation. Also, the field names are output by a disassembler that formats existing tables into TDL code.

21.2.2 TDL Grammar Specification

```
// Root Term
DataTable := FieldList
// Field Terms
FieldList := Field | <field fieldlist>
Field := <fielddefinition optionalfieldcomment> | CommentField
FieldDefinition :=
    // Fields for predefined (known) ACPI tables
    <OptionalFieldName ':' FieldValue> |

    // Generic data types (used for custom or undefined ACPI tables)
    <'uint8' ':' integerexpression> // 8-bit unsigned integer
    <'uint16' ':' integerexpression> // 16-bit unsigned integer
    <'uint24' ':' integerexpression> // 24-bit unsigned integer
    <'uint32' ':' integerexpression> // 32-bit unsigned integer
    <'uint40' ':' integerexpression> // 40-bit unsigned integer
    <'uint48' ':' integerexpression> // 48-bit unsigned integer
    <'uint56' ':' integerexpression> // 56-bit unsigned integer
    <'uint64' ':' integerexpression> // 64-bit unsigned integer
    <'string' ':' String> // Quoted ASCII string
    <'unicode' ':' String> // quoted ascii string -> Unicode string
    <'buffer' ':' byteconstlist> // Raw buffer of 8-bit unsigned integers
    <'guid' ':' guid> // In GUID format
    <'label' ':' label> // ASCII label - unquoted string

OptionalFieldName := Nothing | AsciiCharList // Optional field name/description
FieldValue := IntegerExpression | String | Buffer | Flags | Label
OptionalFieldComment := Nothing | <'[' asciicharlist ']'>
CommentField := <'/' asciicharlist newline> | <'/' asciicharlist '/'> | <'[' asciicharlist ']'>
// Data Expressions
IntegerExpression := Integer | <integerexpression integeroperator integerexpression> | <'(' integerexpression ')>
// Operators below are shown in precedence order. The precedence rules are the same as the C language.
// Parentheses have precedence over all operators.
IntegerOperator :=
```

```

    '!' | '~' | '*' | '/' | '%' | '+' | '-' | '<<' | '>>' | '<' | '>' | '<=' | '>=' | '==' | '!=' | '&' | '^' | '|' | '&&' |
    '||'

// Data Types
String := <"" asciicharlist "">
Buffer := ByteConstList
Guid := <dwordconst '-' wordconst '-' wordconst '-' wordconst '-' const48>
Label := AsciiCharList

// Data Terms
Integer := // duplicate definition - see previous chapter ByteConst | WordConst | Const24 | DWord-
    Const | Const40 | Const48 | Const56 | QWordConst | LabelReference
LabelReference := <' '$' label>
Flags := OneBit | TwoBits
ByteConstList := ByteConst | <byteconst ' ' byteconstlist>
AsciiCharList := Nothing | PrintableAsciiChar | <printableasciichar asciicharlist>

// Terminals
ByteConst := 0x00-0xFF
WordConst := 0x0000 - 0xFFFF
Const24 := 0x000000 - 0xFFFFFF
DWordConst := 0x00000000 - 0xFFFFFFFF
Const40 := 0x0000000000 - 0xFFFFFFFFFFFF
Const48 := 0x000000000000 - 0xFFFFFFFFFFFFFFF
Const56 := 0x000000000000000 - 0xFFFFFFFFFFFFFFFFF
QWordConst := 0x0000000000000000 - 0xFFFFFFFFFFFFFFFFFFFF
OneBit := 0 - 1
TwoBits := 0 - 3
PrintableAsciiChar := 0x20 - 0x7E
NewLine := 'n'

```

21.2.3 Data Types

21.2.3.1 Integers

All integers in ACPI are unsigned. Four major types of unsigned integers are supported by the compiler: Bytes, Words, DWords and QWords. In addition, for special cases, there are some odd sized integers such as 24-bit and 56-bit. The actual required width of an integer is defined by the ACPI table. If an integer is specified that is numerically larger than the width of the target field within the input source, an error is issued by the compiler. Integers are expected by the data table compiler to be entered in hexadecimal with no “hex” prefix.

Examples:

```
[001] Revision : 04 // Byte (8-bit)
[002] C2 Latency : 0000 // Word (16-bit)
[004] DSDT Address : 00000001 // DWord (32-bit)
[008] Address : 0000000000000001 // QWord (64-bit)
```

Length of non-power-of-two examples:

```
[003] Reserved : 000000 // 24 bits
[007] Capabilities : 0000000000000000 // 56 bits
```

21.2.3.2 Integer Expressions

Expressions are supported in all fields that require an integer value.

Supported operators (Standard C meanings, in precedence order):

```
() Parentheses
! Logical NOT
~ Bitwise ones compliment (NOT)
* Multiply
/ Divide
% Modulo
+ Add
- Subtract
<< Shift left
>> Shift right
< Less than
> Greater than
<= Less than or equal
>= Greater than or equal
== Equal
!= Not Equal
& Bitwise AND
^ bitwise Exclusive OR
| Bitwise OR
&& Logical AND
|| Logical OR
```

Examples:

```
[001] Revision : 04 \* (4 + 7) // Byte (8-bit)
[002] C2 Latency : 0032 + 8 // Word (16-bit)
```

21.2.3.3 Flags

Many ACPI tables contain flag fields. For these fields, only the individual flag bits need to be specified to the compiler. The individual bits are aggregated into a single integer of the proper size by the compiler.

Examples:

```
[002] Flags (decoded below) : 0005
      Polarity : 1
      Trigger Mode : 1
```

In this example, only the Polarity and Trigger Mode fields need to be specified to the compiler (as either zero or one). The compiler then creates the final 16-bit Flags field for the ACPI table.

21.2.3.4 Strings

Strings must always be surrounded by quotes. The actual string that is generated by the compiler may or may not be null-terminated, depending on the table definition in the ACPI specification. For example, the OEM ID and OEM Table ID in the common ACPI table header (shown above) are fixed at six and eight characters, respectively. They are not necessarily null terminated. Most other strings, however, are of variable-length and are automatically null terminated by the compiler. If a string is specified that is too long for a fixed-length string field, an error is issued. String lengths are specified in the definition for each relevant ACPI table.

Escape sequences within a quoted string are not allowed. The backslash character “\” refers to the root of the ACPI namespace.

Examples:

```
[008]          Oem Table ID : "TEMPLATE"    // Fixed length
[006] Processor UID String : "\CPU0 "      // Variable length
```

21.2.3.5 Buffers

A buffer is typically used whenever the required binary data is larger than a QWord, or the data does not fit exactly into one of the standard integer widths. Examples include UUIDs and byte data defined by the SLIT table.

Examples:

```
// SLIT entry
[032] Locality 0 [0A 10 16 17 18 19 1A 1B 1C 1D 1E 1F 20 21 22 23 \] 24 25 26 27 28 29 2A 2B 2C
      2D 2E 2F 30 31 32 33
// DMAR entry
[002] PCI Path : 1F 07
```

Each hexadecimal byte should be entered separately, separated by a space. The continuation character (backslash) may be used to continue the buffer data to more than one line.

21.2.4 Fields Set Automatically by the Compiler

There are several types of ACPI table fields that are set automatically by the compiler. This simplifies the process of ACPI table development by relieving the programmer from these tasks.

Checksums: All ACPI table checksums are computed and inserted automatically. This includes the main checksum that appears in the standard ACPI table header, as well as any additional checksum fields such as the extended checksum that appears in the ACPI 2.0 RSDP.

Table and Subtable Lengths: All ACPI table lengths are computed and inserted automatically. This includes the master table length that appears in the common ACPI table header, and the length of any internal subtables as applicable.

Examples:

```
[004] Table Length : 000000F4
[001] Subtable Type : 08 <platform interrupt sources>
[001]           Length : 10
[001] Subtable Type : 01 <memory affinity>
[001]           Length : 28
```

Flags: As described in the previous section, individual flags are aggregated automatically by the compiler and inserted into the ACPI table as the correctly sized and valued integer.

Compiler IDs: The data table compiler automatically inserts the ID and current revision for iASL into the common ACPI table header for each table during compilation.

21.2.5 Special Fields

Reserved Fields: All fields that are declared as Reserved by the table definition within the ACPI (or other) specification should be set to zero.

Table Revision: This field in the common ACPI table header is often very important and defines the structure of the remaining table. The developer should take care to ensure that this value is correct and current. This field is not set automatically by the compiler. It is instead used to indicate which version of the table is being compiled.

Table Signature: There are several table signatures within ACPI that are either different from the table name, or have unusual length:

FADT - signature is “FACP”.

MADT - signature is “APIC”.

RSDP - signature is “RSD PTR ” (with trailing space)

21.2.6 TDL Generic Data Types

The following data types are used to construct ACPI tables that are not predefined (known) by the TDL compiler:

UINT8 Generates an 8-bit unsigned integer
UINT16 Generates a 16-bit unsigned integer
UINT24 Generates a 24-bit unsigned integer
UINT32 Generates a 32-bit unsigned integer
UINT40 Generates a 40-bit unsigned integer
UINT48 Generates a 48-bit unsigned integer
UINT56 Generates a 56-bit unsigned integer
UINT64 Generates a 64-bit unsigned integer
String Generates a null-terminated ASCII string (ASCIIZ)
Unicode Generates a null terminated Unicode (UTF-16) string
Buffer Generates a buffer of 8-bit unsigned integers
GUID Generates an encoded GUID in a 16-byte buffer
Label Generates a Label at the current location (offset) within the table. This label can be referenced within integer expressions by prepending the label with a ‘\$’ sign.

21.2.7 Defining a Known ACPI Table in TDL

It is expected that most ACPI tables that will be created via the TDL compiler are ACPI tables that are known to the compiler. This means that the compiler contains the required structure and definition of the table, as per the ACPI specification or other specification for that table.

For these known ACPI tables, specifying the data for the table involves simply defining the value for each field in the table. The compiler automatically types the data, performs range and any value checks, and generates the appropriate output.

The starting point for any of the known ACPI tables is the document that specifies the format of the table (usually the ACPI specification), or a table template file generated by an ASL compiler, or even the output of an AML disassembler. Writing the TDL code involves implementing one line of code for each data item specified in the table definition itself.

For example, the table header for an ACPI table can be defined as simply a sequence of strings and integers. The TDL compiler will format these data items into a 36-byte ACPI header:

```

: "ECDT"
: 00000000
: 01
: 00
: "OEM "
: "MACHINE1"
: 00000001
: ""
: 00000000
    
```

21.2.8 Defining an Unknown or New ACPI table in TDL

For ACPI tables that are new or whose formats are otherwise unknown to the compiler, “generic” data types are introduced to allow the definition of these tables using explicit data types.

Examples of Generic Data Types:

```

Label : StartRecord
UINT8 : 11
UINT16 : $EndRecord - $StartRecord // Record length
UINT24 : 112233
UINT32 : 11223344
UINT56 : 11223344556677
UINT64 : 1122334455667788

String : "This is a string"
DevicePath : "\PciRoot(0)\Pci(0x1f,1)\Usb(0,0)"
Unicode : "This string will be encoded to Unicode"

Buffer : AA 01 32 4C 77
GUID : 11223344-5566-7788-99aa-bbccddeeff00
Label : EndRecord
    
```

21.2.9 Table Definition Language Examples

21.2.9.1 ECDT Disassembler Output

The output of the iASL disassembler may be used as direct input to the TDL compiler:

```

[000h 0000 4] Signature : "ECDT" [Embedded Controller Data Table]
[004h 0004 4] Table Length : 0000004E
[008h 0008 1] Revision : 01
[009h 0009 1] Checksum : F4
[00Ah 0010 6] Oem ID : "INTEL "
[010h 0016 8] Oem Table ID : "TEMPLATE"
[018h 0024 4] Oem Revision : 00000001
[01Ch 0028 4] Asl Compiler ID : "INTL"
[020h 0032 4] Asl Compiler Revision : 20110316

[024h 0036 12] Command/Status Register : [Generic Address Structure]
[024h 0036 1] Space ID : 01 [SystemIO]
[025h 0037 1] Bit Width : 08
[026h 0038 1] Bit Offset : 00
[027h 0039 1] Encoded Access Width : 00 [Undefined/Legacy]
    
```

(continues on next page)

(continued from previous page)

```

[028h 0040 8]                Address : 00000000000000066

[030h 0048 12]               Data Register :      [Generic Address Structure]
[030h 0048 1]                Space ID : 01      [SystemIO]
[031h 0049 1]                Bit Width : 08
[032h 0050 1]                Bit Offset : 00
[033h 0051 1]                Encoded Access Width : 00 [Undefined/Legacy]
[034h 0052 8]                Address : 00000000000000062

[03Ch 0060 4]                UID : 00000000
[040h 0064 1]                GPE Number : 09
[041h 0065 13]               Namepath : "\_SB.PCI0.EC"

Raw Table Data: Length 78 (0x4E)

0000: 45 43 44 54 4E 00 00 00 01 F4 49 4E 54 45 4C 20  ECDTN.....INTEL
0010: 54 45 4D 50 4C 41 54 45 01 00 00 00 49 4E 54 4C  TEMPLATE....INTL
0020: 16 03 11 20 01 08 00 00 66 00 00 00 00 00 00 00  ... ....f.....
0030: 01 08 00 00 62 00 00 00 00 00 00 00 00 00 00 00  ....b.....
0040: 09 5C 5F 53 42 2E 50 43 49 30 2E 45 43 00      .\_SB.PCI0.EC.
    
```

21.2.9.2 ECDT Definition with Field Comments

Similar to the disassembler output but simpler:

```

Signature           : "ECDT" [Embedded Controller Data Table]
Table Length       : 0000004E
Revision           : 01
Checksum           : F4
Oem ID             : "INTEL "
Oem Table ID       : "TEMPLATE"
Oem Revision        : 00000001
Asl Compiler ID    : "INTL"
Asl Compiler Revision : 20110316

Command/Status Register : [Generic Address Structure]
Space ID              : 01 [SystemIO]
Bit Width             : 08
Bit Offset            : 00
Encoded Access Width  : 00 [Undefined/Legacy]
Address               : 00000000000000066

Data Register        : [Generic Address Structure]
Space ID              : 01 [SystemIO]
Bit Width             : 08
Bit Offset            : 00
Encoded Access Width  : 00 [Undefined/Legacy]
Address               : 00000000000000062

UID                  : 00000000
GPE Number           : 09
Namepath             : "\_SB.PCI0.EC"
    
```

21.2.10 Minimal ECDT Definition

An example of a minimal ECDT definition with no Field Names:

```

: "ECDT" [Embedded Controller Boot Resources Table]
: 0000004E
: 01
: F4
: "INTEL "
: "TEMPLATE"
: 00000001
: "INTL"
: 20110316

: [Generic Address Structure]
: 01 [SystemIO]
: 08
: 00
: 00 [Undefined/Legacy]
: 00000000000000066

: [Generic Address Structure]
: 01 [SystemIO]
: 08
: 00
: 00 [Undefined/Legacy]
: 00000000000000062

: 00000000
: 09
: "\_SB.PCI0.EC"

```

21.2.10.1 Generic ACPI Table Definition

Tables that are not known to the TDL compiler can be defined by using the generic data types. All ACPI tables are assumed to have the common ACPI header, however:

```

Signature           : "OEMZ"
Table Length       : 00000052
Revision          : 01
Checksum          : 6C
Oem ID            : "TEST"
Oem Table ID      : "CUSTOM "
Oem Revision       : 00000001
Asl Compiler ID   : "INTL"
Asl Compiler Revision : 00000001

                UINT8 : 01
                UINT8 : 08
                UINT8 : 00
                UINT8 : 00
                UINT64 : 00000000000000066
                UINT32 : 00000000
                UINT8 : 12
                String : "Hello World!"

```

APPENDIX A: DEVICE CLASS SPECIFICATIONS

This section defines the behavior of devices as that behavior relates to power management and, specifically, to the four device power states defined by ACPI. The goal is enabling device vendors to design power-manageable products that meet the basic needs of OSPM and can be utilized by any ACPI-compatible operating system.

A.1 Overview

The power management of individual devices is the responsibility of a policy owner in the operating system. This software element will implement a power management policy that is appropriate for the type (or class) of device being managed. Device power management policy typically operates in conjunction with a global system power policy implemented in the operating system.

In general, the device-class power management policy strives to reduce power consumption while the system is working by transitioning among various available power states according to device usage. The challenge facing policy owners is to minimize power consumption without adversely impacting the system's usability. This balanced approach provides the user with both power savings and good performance.

Because the policy owner has very specific knowledge about when a device is in use or potentially in use, there is no need for hardware timers or such to determine when to make these transitions. Similarly, this level of understanding of device usage makes it possible to use fewer device power states. Generally, intermediate states attempt to draw a compromise between latency and consumption because of the uncertainty of actual device usage. With the increased knowledge in the OS, good decisions can be made about whether the device is needed at all. With this ability to turn devices off more frequently, the benefit of having intermediate states diminishes.

The policy owner also determines what class-specific events can cause the system to transition from sleeping to working states, and enables this functionality based on application or user requests. Notice that the definition of the wake events that each class supports will influence the system's global power policy in terms of the level of power management a system sleeping state can attain while still meeting wake latency requirements set by applications or the user.

A.2 Device Power States

The following definitions apply to devices of all classes:

- **D0.** State in which device is on and running. It is receiving full power from the system and is delivering full functionality to the user.
- **D1.** Class-specific low-power state (defined in the following section) in which device context may or may not be lost. Buses in D1 cannot do anything to the bus that would force devices on that bus to lose context.
- **D2.** Class-specific low-power state (defined in the following section) in which device context may or may not be lost. Attains greater power savings than D1. Buses in D2 can cause devices on that bus to lose some context

(for example, the bus reduces power supplied to the bus). Devices in D2 must be prepared for the bus to be in D2 or higher.

- **D3.** State in which device is off and not running. Device context is lost. Power can be removed from the device.

Device power-state transitions are typically invoked through bus-specific mechanisms (for example, ATA Standby, USB Suspend, and so on). In some cases, bus-specific mechanisms are not available and device-specific mechanisms must be used. Notice that the explicit command for entering the D3 state might be the removal of power.

It is the responsibility of the policy owner (or other software) to restore any lost device context when returning to the D0 state.

A.2.1 Bus Power Management

Policy owners for bus devices (for example, PCI, USB, Small Computer System Interface [SCSI]) have the additional responsibility of tracking the power states of all devices on the bus and for transitioning the bus itself to only those power states that are consistent with those of its devices. This means that the bus state can be no lower than the highest state of one of its devices. However, enabled wake events can affect this as well. For example, if a particular device is in the D2 state and set to wake the system and the bus can only forward wake requests while in the D1 state, then the bus must remain in the D1 state even if all devices are in a lower state.

Below are summaries of relevant bus power management specifications with references to the sources.

A.2.2 Display Power Management

Refer to the Display Power Management Signaling Specification (DPMS), available from:

Video Electronics Standards Association (VESA)
2150 North First Street
Suite 440
San Jose, CA 95131-2029

A DPMS-compliant video controller and DPMS-compliant monitor use the horizontal and vertical sync signals to control the power mode of the monitor. There are 4 modes of operation: normal, standby, suspend and off. DPMS-compliant video controllers toggle the sync lines on or off to select the power mode.

A.2.3 PCMCIA/PCCARD/CardBus Power Management

PCMCIA and PCCARD devices do not have device power states defined. The only power states available are on and off, controlled by the host bus controller. The CardBus specification is a superset of the PCCARD specification, incorporating the power management specification for PCI bus. Power management capabilities query, state transition commands and wake event reporting are identical.

A.2.4 PCI Power Management

For information on PCI Power Management, see the PCI Special Interest Group (PCI-SIG) website. You can find a link to this site at <http://uefi.org/acpi>, under the heading “PCI Sig”.

- **PCI Bus Power Management Capabilities Query.** PCI Bus device capabilities are reported via the optional Capabilities List registers, which are accessed via the Cap_Ptr.
- **PCI Bus Power Management State Transition Commands.** PCI Bus device power states are controlled and queried via the standard Power Management Status/Control Register (PMCSR).
- **PCI Bus Wakeup Event Reporting.** PCI wake events are reported on the optional PME# signal, with setting of the Wake_Int bit in the PMCSR. Wake event reporting is controlled by the Wake_En bit in the PMCSR register.

A.2.5 USB Power Management

See the Universal Serial Bus Implementers Forum (USB-IF) Web site, as listed at <http://uefi.org/acpi> under the heading “Universal Serial Bus Power Management”.

- **USB Power Management Capabilities Query.** USB device capabilities are reported to the USB Host via the standard Power Descriptors. These address power consumption, latency time, wake support, and battery support and status notification.
- **USB Power Management State Transition Commands.** USB device power states are controlled by the USB Host via the standard SET_FEATURE command. USB device power states are queried via the standard USB GET_STATUS command.
- **USB Wakeup Event Reporting.** USB wake event reporting is controlled using the SET_FEATURE command, with value DEVICE_REMOTE_WAKEUP. USB wake events are reported by sending remote wake resume signaling.

A.2.6 Device Classes

Below is a list of the class-specific device power management definitions available in this specification. Notice that there exists a default device class definition that applies to all devices, even if there is a separate, class-specific section that adds additional requirements.

- **Audio Device Class.** Applies to audio devices.
- **COM Port Device Class.** Applies to COM ports devices.
- **Display Device Class.** Applies to CRT monitors, LCD panels, and video controllers for those devices.
- **Input Device Class.** Applies to standard types of input devices such as keyboards, keypads, mice, pointing devices, joysticks, and game pads, plus new types of input devices such as virtual reality devices.
- **Modem Device Class.** Applies to modem and modem-like (for example, ISDN terminal adapters) devices.
- **Network Device Class.** Applies specifically to Ethernet and token ring adapters. ATM and ISDN adapters are not supported by this specification.
- **PC Card Controller Device Class.** Applies to PC Card controllers and slots.
- **Storage Device Class.** Applies specifically to ATA hard disks, floppy disks, ATAPI and SCSI CD-ROMs, and the IDE channel.

A.3 Default Device Class

The requirements expressed in this section apply to all devices, even if there is a separate, class-specific power management definition that identifies additional requirements.

Table A-1: Default Power State Definitions

State	Definition
D0	Device is on and running. It is receiving full power from the system, and is delivering full functionality to the user.
D1	This state is not defined and not used by the default device class.
D2	This state is not defined and not used by the default device class.
D3	Device is off and not running. Device context is assumed lost, and there is no need for any of it to be preserved in hardware. This state should consume the minimum power possible. Its only requirement is to recognize a bus-specific command to re-enter D0. Power can be removed from the device while in D3. If power is removed, the device will receive a bus-specific hardware reset upon reapplication of power, and should initialize itself as in a normal power on.

A.3.1 Default Power Management Policy

Table A-2: Default Power Management Policy

Present State	Next State	Cause
D0	D3	Device determined by the OS to not be needed by any applications or the user. System enters a sleeping state.
D3	D0	Device determined by the OS to be needed by some application or the user.

A.3.2 Default Wake Events

There are no default wake events, because knowledge of the device is implicit in servicing such events. Devices can expose wake capabilities to OSPM, and device-specific software can enable these, but there is no generic application-level or OS-wide support for undefined wake events.

A.3.3 Default Minimum Power Capabilities

All devices must support the D0 and D3 states. Functionality available in D0 must be available after returning to D0 from D3 without requiring a system reboot or any user intervention. This requirement applies whether or not power is removed from the device during D3.

A.4 Audio Device Class

The requirements expressed in this section apply to audio devices

A.4.1 Audio Device Power State Definitions

Table A-3: Audio Device Power State Definitions

State	Status	Definition
D0	Required	Power is on. Device is operating.
D1	Optional	Power consumption is less than D0 state. Device must be able to transition between D0 and D1 states within 100 ms. No audio samples may be lost by entering and leaving this state.
D2	Required	Power consumption is less than D0 state. Device must be able to transition between D0 and D2 states within 100 ms. Audio samples may be lost by entering and leaving this state.
D3	Required	The device is completely off or drawing minimal power. For example, a stereo will be off, but a light-emitting diode (LED) may be on and the stereo may be listening to IR commands.

If a device is in the D1 or D2 state it must resume within 100 ms. A device in the D3 state may take as long as it needs to power up. It is the responsibility of the policy owner to advertise to the system how long a device requires to power up.

All audio devices must be capable of D0, D2 and D3 states. It is desirable that an audio device be capable of D1 state. The difference between D1 and D2 is that a device capable of D1 can maintain complete state information in reduced power mode. The policy owner or other software must save all states for D2-capable devices. Some audio samples may be lost in transitioning into and out of the D2 state.

Notice that the D1 state was added to allow digital signal processor (DSP)-equipped audio hardware to exploit low-power modes in the DSP. For example, a DSP may be used to implement Dolby AC-3 Decode. When paused it stops playing audio, but the DSP may contain thousands of bytes worth of state information. If the DSP supports a low-power state, it can shut down and later resume from exactly the audio sample where it paused without losing state information.

A.4.2 Audio Device Power Management Policy

For the purpose of the following state transition policy, the following device-specific operational states are defined:

- **Playing.** Audio is playing.
- **Recording:**
- **Foreground.** Normal application is recording. Recording is considered foreground unless specifically designated low priority.
- **Background.** Speech recognition or speech activity detection is running. Recording may be preempted by foreground recording or playing. Any audio recording may be designated as background.
- **Full Duplex.** Device is simultaneously playing and recording.
- **Paused.** File handle is open. Only devices that are playing, foreground recording or in full duplex operation may be paused. Background recording may not be paused. State is static and never lost. The paused state assumes that a device must transition to the resumed state rapidly. Playing or recording must be resumed within 100 ms. No audio samples may be lost between the device is paused and later resumed.

- **Closed.** No file handle is open.

Table A-4: Audio Device Power Management Policy

Present State	Next State	Cause
D3	D0	Audio device moves from closed to open state or paused when the device receives the resume command.
D0	D1	Audio device receives pause command. If device is D1 capable, this state is preferred. If not, the device driver will preserve context, and the device will be set to D2.
D2/D1	D0	Audio device receives a resume command.
D0	D2	Audio device is closed. Audio inactivity timer started.
D2	D3	Audio inactivity timer expires.
D0	D3	Audio device is in background record mode and receives power-down command.

When an audio device is in the D0 state it will refuse system requests to transition to D3 state unless it is in background record mode. When an audio device is paused (D1 or D2) and it receives a request to transition to the D3 state, it will save the state of the audio device and transition to the D3 state.

Since multimedia applications often open and close audio files in rapid succession, it is recommended that an inactivity timer be employed by the policy owner to prevent needless shutdowns (D3 transitions) of the audio hardware. For example, frequent power cycling may damage audio devices powered by vacuum tubes.

A.4.3 Audio Device Wake Events

An audio device may be a wake device. For example, a USB microphone designed for security applications might use the USB wake mechanism to signal an alarm condition.

A.4.4 Audio Device Minimum Power Capabilities

All audio devices must be capable of D0, D2 and D3 power states. If the device is capable of maintaining context while in a low-power state it should advertise support for D1. Transitional latency for the D2 or D3 states must be less than 100 ms. There are no latency restrictions for D3 transitions, but the policy owner should advertise the amount of time required.

A.5 COM Port Device Class

The requirements expressed in this section apply to Universal Asynchronous Receiver/Transmitters (UARTs) such as the common NS16550 buffered serial port and equivalents.

The two required states for any power-managed COM Port are full on (D0) and full off (D3). This in turn requires that the COM port hardware be power-manageable by ACPI control methods for COM ports that are on system boards, or by standard bus power management controls for COM ports that are on add-in cards (for example, PCI). Because of this, ISA-based COM port add-in cards will not be able to meet this requirement, and therefore cannot be compliant with this specification.

A.5.1 COM Port Power State Definitions

Table A-5: COM Port Device Power State Definitions

State	Status	Definition
D0	Required	Line drivers are on. UART context is preserved.
D1	N/A	This state is not defined for COM Ports. Use the D3 state instead.
D2	N/A	This state is not defined for COM Ports. Use the D3 state instead.
D3	Required	Line drivers are off (unpowered; outputs isolated from devices attached to the port). UART context is lost. Latency to return to D0 is less than 1 second.

A.5.2 COM Power Power Management Policy

Table A-6: COM Port Device Power Management Policy

Present State	Next State	Cause
D3	D0	Power-on reset COM port opened by an application
D0	D3	COM port closed System enters sleeping state while wake is disabled on this device. System enters sleeping state while wake is enabled on this device and the device is capable of generating wake to the system from state D3.

A.5.3 COM Port Wake Events

If the COM port is capable of generating wake events, asserting the “ring indicator” line (V.24 circuit 125) will cause the COM port to assert a wake event. There are two common mechanisms that may be employed (either one or both) for performing machine wake using COM ports.

The first provides a solution that is capable of waking the PC whether the UART is powered (D0) or not (D3). Here, the “ring indicator” line (from V.24 circuit 125) is commonly connected directly to the system wake device in addition to being connected to the UART. While this implementation is normative for COM ports located on system motherboards (see the ACPI specification), it could also be done by add-in cards with COM ports that reside on buses supporting system wake from devices in D3 (for example, PME# signal on PCI).

The second mechanism requires that the UART be powered (D0) to use the UART’s interrupt output pin to generate the wake event instead. When using this method, the OS COM port policy owner or power management control methods are expected to configure the UART. Although any UART interrupt source (for example, ‘data ready’) could theoretically be used to wake the system, these methods are beyond the scope of this document.

A.5.4 COM Port Minimum Power Capabilities

A COM port conforming to this specification must support the D0 and D3 states.

A.6 Display Device Class

The requirements expressed in this section apply to all devices engaged in the display of program content, which includes full screen display devices, display controllers, and graphics adapters. This class does not include video capture devices unless they are children of the graphics adapter. This class does not include edge displays or hardware indicators for device states.

While saving power from the display and adapter are primary goals of Display Device Class power management definitions, the definitions are also intended to ensure that the user perceives the system as “off” during system sleeping states, as required above. When the system enters a lower power state, the screen must go black so the user knows the system is idle. This is important because devices that cannot actually save power (standard televisions, for example) can still support the user notice of system idle by going black.

A.6.1 Display Device Power State Definitions

Table A-7: CRT Monitors Power State Definitions

State	Status	Definition
D0	Required	This state is equivalent to the “On” state defined in the VESA DPMS specification (see Related Documents) and is signaled to the display using the DPMS method. Display is fully on Video image is active
D1	Optional	This state is equivalent to the “Standby” state defined in the VESA DPMS and is signaled to the display using the DPMS method. Display is functional but may be conserving energy Video image is blank Latency to return to D0 must be less than 5 seconds
D2	Required	This state is equivalent to the “Suspend” state defined in the VESA DPMS specification and is signaled to the display using the DPMS method. Display is functional and conserving energy Video image is blank Latency to return to D0 is less than 10 seconds
D3	Required	This state is equivalent to the “Off” state defined in the VESA DPMS specification and is signaled to the display using the DPMS method. Display is non-functional Video image is blank

CRT Monitors are a special case in power management. On the one hand, they support a common defined method (DPMS) for changing power states. On the other hand, that procedure and the CRT support is extremely slow and out of keeping with other faster power control methods used by other forms of display. This definition should not preclude the use of faster and more effective methods of transitioning the CRT if they are available and known to the controller. DPMS is not recommended as solution for new display devices in the future.

Table A-8: Internal Flat Panel Displays Power State Definitions

State	Status	Definition
D0	Required	This state is equivalent to the “On” state for a DPMS device, but is signaled to the panel by the correct application of power and/or controller specific signaling. Display is fully on Backlight (if present) is fully on(subject to performance state requirements - see below) Video image is active
D1	Optional	This state is not required to be physically different than a D3 state if the device is able to meet the resume requirement and the driver is able to restore state. Display retains internal state but may be conserving energy Backlight(if present) is fully off Video image is blank Latency to return to D0 must be less than 500 milliseconds
D2	Optional	This state is not required to be physically different than a D3 state if the device is able to meet the resume requirement and the driver is able to restore state. Display retains state but is conserving energy Backlight (if present) is fully off; Video image is blank Latency to return to D0 is less than 500 milliseconds
D3	Required	This state is equivalent to the “Off” state defined in the VESA DPMS specification. It is signaled by the removal of power or possibly by controller-specific signaling. Display is non-functional Backlight (if present) is fully off. Video image is blank Latency to return to D0 is less than 500 milliseconds

Internal flat panels (also known as local flat panels or sometimes as LCDs) do not normally support or require DPMS signaling to change power states. Instead, controllers capable of managing such panels tend to provide vendor-specific methods to control internal flat panels, often involving special sequencing of power signals to the panel. Some may be managed only by the application or removal of power.

Backlight control for power management states is likewise controller and even platform specific. Note that on-off backlight control for power management states is often unrelated to backlight intensity or brightness control that is used while in the D0 state.

The 500 milliseconds is only to allow some existing hardware to function . The target for new devices should be 100 milliseconds.

Table A-9: External Digital Displays Power State Definitions

State	Status	Definition
D0	Required	This state is equivalent to the “On” state for a DPMS device, but is signaled to the display by the correct application of power and/or controller specific signaling. Display is fully on. Video image is active.
D1	Optional	This state is not required to be physically different than a D3 state if the device is able to meet the resume requirement and the driver is able to restore state. It is signaled by the removal of display output and time expiring. The physical state entered is no different than D2. Display retains internal state but may be conserving energy Video image is blank Latency to return to D0 must be less than 250 milliseconds*.
D2	Optional	This state is not required to be physically different than a D3 state if the device is able to meet the resume requirement and the driver is able to restore state. It is signaled by the removal of display output and time expiring The physical state entered is no different than D1. Display retains state but is conserving energy. Video image is blank. Latency to return to D0 is less than 250 milliseconds*.
D3	Required	This state is equivalent to the “Off” state defined in the VESA DPMS specification. It is signaled by the removal of display output and time expiring. Display is non-functional. Video image is blank. Latency to return to D0 is less than 250 milliseconds*.

Note: * Although a latency of 250 milliseconds is shown here, because not all devices in this group are faster, the

target resume time for a new device should be less than 100 milliseconds.

Table A-10: Standard TV Devices and Analog HDTVs Power State Definitions

State	Status	Definition
D0	Required	This state is equivalent to the “On” state for a DPMS device. Display is fully on Video image is active
D1	Optional	Video image is blank Latency to return to D0 must be less than 100 milliseconds
D2	Optional	Video image is blank Latency to return to D0 must be less than 100 milliseconds
D3	Required	This state is not equivalent to the “Off” state defined in the VESA DPMS specification because not power is actually saved. Video image is blank Latency to return to D0 is less than 100 milliseconds

Table A-11: Other (new) Full Screen Display Devices Power State Definitions

Some devices not specifically defined above already exist, such as projectors that emulate CRTs or HDTVs. Others may be coming. It is important for any device used for full screen display to support power transitions and power management states, but the primary requirement for the method should be low overhead.

State	Status	Definition
D0	Required	This state is equivalent to the “On” state for a DPMS device, but is signaled to the panel by the correct application of power and/or device specific signaling known to the controller. Display is fully on Video image is active
D1	Optional	This state is not required to be physically different than a D3 state if the device is able to meet the resume requirement and the driver is able to restore state. It is signaled to the panel by the correct application of power and/or device specific signaling known to the controller. Display retains internal state but may be conserving energy Video image is blank Latency to return to D0 must be less than 100 milliseconds
D2	Optional	This state is not required to be physically different than a D3 state if the device is able to meet the resume requirement and the driver is able to restore state. It is signaled to the panel by the correct application of power and/or device specific signaling known to the controller. Display retains state but is conserving energy Video image is blank Latency to return to D0 is less than 100 milliseconds
D3	Required	This state is equivalent to the “Off” state defined in the VESA DPMS specification. It is signaled by the removal of display output and/or device specific methods known to the controller. Display is non-functional Video image is blank Latency to return to D0 is less than 250 milliseconds

Note: * Although a latency of 250 milliseconds is shown here, because not all devices in this group are faster, the target resume time for a new device should be less than 100 milliseconds.

Table A-12: Video Controllers (Graphics Adapters) Power State Definitions

State	Status	Definition
D0	Required	Back-end is on Video controller context is preserved Video memory contents are preserved
D1	Optional	Back-end is off, except for CRT control signaling (DPMS) Video controller context is preserved Video memory contents is preserved Latency to return to D0 is less than 100 milliseconds
D2	Optional	Back-end is off, except for CRT control signaling (DPMS) Video controller context is lost Video memory contents is lost Latency to return to D0 is less than 200 milliseconds
D3	Required	Back-end is off Video controller context is lost (power removed) Video memory contents is lost (power removed) Latency to return to D0 is less than 200 milliseconds

A.6.1.1 Display Codecs

Like the displays they control, display codecs are children of the adapter and cannot be in a higher state than the adapter or a lower state than the displays they control . It is generally not helpful to deal with codecs entirely separately from the adapter or the displays they control. While it may vary from device to device, a codec will either be safely powered down when its display is powered down or it may require power as long as the adapter receives power.

A.6.2 Display Device Power Management Policy

Table A-13: Display Device Power Management Policy

Present State	Next State	Cause
D0	D1	User inactivity for a period of time (T1)
D1	D2	User inactivity for a period of time (T2 > T1)
D2	D3	User inactivity for a period of time (T3 > T2)
D1/D2/D3	D0	User activity or application UI change (for example, dialog pop-up)

These state transition definitions apply to both the full screen display and the video controller. However, the control of the two devices is independent, except that a video controller will never be put into a lower power state than its full screen display. Also, while full screen displays can transition directly from D1 to D3 or from D2 to D3, the adapters require a transition to D0 from D1 or D2 before entering D3.

Transitions for the video controller are commanded via the bus-specific control mechanism for device states. Monitor/LCD transitions are commanded by signaling from the video controller and are only generated as a result of explicit commands from the policy-owner. Full screen display power control is functionally independent from any other interface the monitor may provide (such as USB). For instance, Hubs and HID devices in the monitor enclosure may be power-managed by their driver over the USB bus, but the Monitor/LCD device itself may not; it must be power-managed from the video controller using the methods above.

A.6.3 Display Device Wake Events

Display devices incorporating a system power switch should generate a wake event when the switch is pressed while the system is sleeping.

A.6.4 Display Device Minimum Power Capabilities

A CRT monitor conforming to this specification must support the D0, D2, and D3 states. Other full screen displays only need to support D0 and D3. Support for the D1 state is optional in all cases. Transitional latencies for the D1 or D2 state must meet the requirements above.

A video controller conforming to this specification must support the D0 and D3 states. Support for the D1 and D2 states is optional. Transitional latencies for the D1 must be less than 100 milliseconds while D2 and D3 must transition to D0 in less than 200 milliseconds.

A.6.5 Display Device Performance States

Performance states for display devices and adapters have one clear difference from defined power management states. There is no display in any power management state higher than D0. However, performance states are all applied within D0, which means they save power while continuing to display. Not all display class devices will support performance states, but in all cases, they must allow continued display where they exist.

A.6.5.1 Common Requirements for Display Class Performance States

The definition of each state (up the line toward the OSPM) must include maximum latency information on transitions into the state and transitions out of the state. (For states other than DPS1, it may be necessary to indicate whether the latency is the time from DPS0 to DPSx or only from DPSx-1 to DPSx.)

Each state has to have a relative weight indicator or a relative power savings indicator (i.e., it can make a difference in OSPM policies whether DPS1 saves 2% power and DPS2 save 75% power even if latency is longer.)

While ASL NameSpace structures may provide some of this information, it is recommended that display class performance states be entered and exited by driver and not by control method wherever possible.

A.6.5.2 Performance states for Full Screen Displays

A.6.5.2.1 CRT Performance States

Some CRTs (in theory) have the capability for “reduced on” – a mode which displays but uses less power than full performance. Even without this capability, a CRT may be able to use reduced refresh or other methods to reduce the total power of displaying.

A.6.5.2.2 Internal Flat Panel

In general, panels consume a fixed amount of power. However, some panels are also capable of supporting reduced refresh. More important, the amount of backlight brightness is a major factor in system power. This clearly needs to be coordinated with direct ASL control methods for brightness and with ambient light sensing when present. However, a performance state may be achieved by offsetting the brightness value computed by other methods, either by a fixed amount or a fixed percentage.

A.6.5.2.3 DVI Full Screen Devices

DVI Devices are normally capable of frequency control and may be able to benefit by frequency control. However, because of sensitivity to signal loss, DVI devices may have limitations on other types of performance control.

A.6.5.2.4 Standard TV and Analog HDTVs

Standard TV and Analog HDTVs do not appear capable of performance states. Codecs controlling them may be capable of power saving, however.

A.6.5.2.5 New Devices

The ability to reduce power while continuing to display will be increasingly important.

A.6.5.3 Performance States for Video Controllers/Display Adapters

Adapters are somewhat limited during performance states because they have to continue to support display on one or more full screen devices. However, they can still do a number of things to support performance states, including

- Changes to basic display and render capabilities, including speed or frequency range supported.
- Feature/Capability/Quality Control - limiting specific hardware features, limiting refresh rates, limiting resolutions.

The limiting factor on what can be supported may sometimes be in the OSPM. If the OSPM support dynamic changes in these features during a performance state change (even if no other time), more opportunities arise.

Once again, the latency on transitions and the power saved by specific states have to be made available to the OSPM in order to use these options effectively.

A.7 Input Device Class

The requirements expressed in this section apply to standard types of input devices such as keyboards, keypads, mice, pointing devices, joysticks, game pads, to devices that combine these kinds of input functionality (composite devices, and so on), and to new types of input devices such as virtual reality devices, simulation devices, and so on.

A.7.1 Input Device Power State Definitions

Table A-14: Input Device Power State Definitions

State	Status	Definition
D0	Required	Device is receiving full power from its power source, delivering full functionality to the user, and preserving applicable context and state information.
D1	Optional	Input device power consumption is greatly reduced. In general, device is in a power management state and is not delivering any functionality to the user except wake functionality if applicable. Device status, state, or other information indicators (for example, LEDs, LCD displays, and so on) are turned off to save power. The following device context and state information should be preserved by the policy owner or other software: Keyboard. Num, caps, scroll lock states (and Compose and Kana states if applicable) and associated LED/indicator states, repeat delay, and repeat rate. Joystick. Forced feedback effects (if applicable). Any input device. All context and state information that cannot be preserved by the device when it's conserving power.
D2	N/A	This state is not defined for input devices, use D1 as the power management state instead.
D3	Required	Input device is off and not running. In general, the device is not delivering any functionality to the user except wake functionality if applicable. Device context and state information is lost.

A.7.2 Input Device Power Management Policy

Table A-15: Input Device Power Management Policy

Present State	Next State	Cause
D3	D0	Requested by the system
D0	D1/D3*	Requested by the system (for example, system goes to sleep with wake enabled)
D0/D1	D3	Requested by the system (for example, system goes to sleep with wake disabled) Power is removed
D1/D3	D0	Device with enabled wake capability requests transition by generating a wake event Requested by the system

Note: This depends on whether the device features D1 or D3 wake capability or not; device will be put in the state with the lowest possible power consumption.

A.7.3 Input Device Wake Events

It is recommended, but not required, that input devices implement and support bus-specific wake mechanisms if these are defined for their bus type. This is recommended because a user typically uses an input device of some kind to wake the system when it is in a power management state (for example, when the system is sleeping).

The actual input data (particular button or key pressed) that's associated with a wake event should never be discarded by the device itself, but should always be passed along to the policy owner or other software for further interpretation. This software implements a policy for how this input data should be interpreted, and decides what should be passed along to higher-level software, and so on.

It is recommended that the device button(s) or key(s) used for power management purposes are clearly labeled with text and/or icons. This is recommended for keyboards and other input devices on which all buttons or keys are typically labeled with text and/or icons that identify their usage.

For example, a keyboard could include a special-purpose power management button (for example, “Power”) that, when pressed during a system sleeping state, generates a wake event. Alternatively, the button(s) on mice and other pointing devices could be used to trigger a wake event.

Examples of more advanced wake events include keyboard wake signaling when any key is pressed, mouse wake signaling on detection of X/Y motion, joystick wake signaling on X/Y motion, and so on. However, in order to avoid accidental or unintentional wake of the system, and to give the user some control over which input events will result in a system wake, it’s suggested that more advanced types of wake events are implemented as features that can be turned on or off by the user (for example, as part of the OSPM user interface).

A.7.4 Input Device Minimum Power Capabilities

An input device conforming to this specification must support the D0 and D3 states. Support for the D1 state is optional.

A.8 Modem Device Class

- The requirements expressed in this section apply to modems and similar devices, such as USB controlled ISDN Terminal Adapters (“digital modems”) and computer-connected telephone devices (“CT phones”). This specification will refer to these devices as “modems; the same considerations apply to digital modems and CT phones unless explicitly stated otherwise.
- The scope of this section is further restricted to modems that support power management using methods defined by the relevant PC-modem connection bus. These include PCI, USB, PCCARD (PCMCIA), CardBus, and modems on the system motherboard described by ACPI system firmware control methods. The scope does not include bus-specific means for devices to alert the host PC (for example, how to deliver a “ringing” message), nor does it address how those alerting operations are controlled.

A.8.1 Technology Overview

Modems are traditionally serial devices, but today modems may be attached to a PC by many different means. Further, many new modems expose a software serial interface, where the modem controller function is implemented in software. This specification addresses three different connection types:

- Traditional connections without power-managed connections (for example, COM, LPT, ISA)
- Power managed connections (for example, PCCARD, CardBus, PCI, USB)
- Motherboard modems

For some of the above modem connection types mentioned, there are three different modem architectures possible:

- Traditional modem (DAA, DSP, and controller in hardware)
- Controller-less design (DAA and DSP in hardware)
- “Soft modem” design (DAA and CODEC only in hardware)

The hardware components of the modem shall be controlled by the relevant bus commands, where applicable (USB, PCI, CardBus). The software components are dependent on the power state of the CPU.

A.8.1.1 Traditional Connections

In older methods (COM, LPT, ISA) the modem is controlled primarily by serialized ASCII command strings (for example, V.25ter) and traditional V.24 (RS-232) out-of-band leads. In these legacy devices, there are no common means for power management other than the power switch for the device, or the entire system unit.

An external modem connected to a COM port or LPT port typically has its own power supply. An LPT port modem might run from the current on the LPT port +5V supply. For COM or LPT port modems, power is typically controlled by a user switch.

The most common modem type is an ISA card with an embedded COM port. From a software standpoint, they are logically identical to external modems, but the modems are powered by the PC system unit. Power is drawn from the ISA bus without independent power switching.

A.8.1.2 Power-Managed Connections

PCMCIA, PCCARD and CardBus slots are powered and power-managed by the system, using means defined in the relevant bus specifications. For PCMCIA and PCCARD devices, only D0 and D3 states are available, via Socket Services in the OS and/or ACPI system firmware. CardBus adds intermediate states, using the same mechanisms defined for PCI Bus.

PCI bus slots are powered and power-managed by the system, using means defined in the PCI specification.

USB devices may be powered by the USB itself (100mA or 500mA), or have their own external power supply. All USB devices are power-managed by the USB bus master, using means defined in the USB specification.

A.8.1.3 Motherboard Modems

A modem embedded in the motherboard is powered by controls on the motherboard. It should be power-managed by using control methods exposed via ACPI system firmware tables.

A.8.2 Modem Device Power State Definitions

Table A-16: Modem Device Power State Definitions

State	Status	Definition
D0	Required	Phone interface is on (may be on or off hook) Speaker is on Controller Context is preserved
D1	N/A	Not defined (do not use)
D2	Optional	Phone interface is not powered by the host (on hook) Speaker is off Controller context is preserved 2 seconds maximum restore time
D3	Required	Phone interface is not powered by host (on hook) Speaker is off Controller context may be lost 5 seconds maximum restore time

A.8.3 Modem Device Power Management Policy

Table A-17: Modem Device Power Management Policy

Present State	Next State	Cause
D2/D3	D0	System issues a bus command to enter the D0 state (for example, an application is answering or originating a call).
D0	D2	System issues a bus command to enter the D2 state. (for example, an application is listening for an incoming call).
D0	D3	System issues a bus command to enter the D3 state (for example, all applications have closed the Modem device).

A.8.4 Modem Device Wake Events

For any type of modem device, wake events (if supported and enabled) are only generated in response to detected “ringing” from an incoming call. All other events associated with modems (V.8bis messages, and so on) require that the PC be in the “working” state to capture them. The methods and signals used to generate the wake may vary as a function of the modem connection (bus) type and modem architecture.

Machine wake is allowed from any modem power state (D0, D2, and D3), and is accomplished by methods described in the appropriate bus power management specification (PCI, USB, PCCARD), or by ACPI system board control methods (for Modem on Motherboard implementations).

If the specific modem implementation or connection type does not enable it to assert system wake signaling, these modems will not be able to wake the machine. The OS modem policy owner will have to retain the PC in the “working” state to perform all types of event detection (including ringing).

A.8.5 Modem Device Minimum Power Capabilities

A modem or similar device conforming to this specification must support the D0 and D3 states. Support of the D2 state is optional.

A.9 Network Device Class

The requirements expressed in this section apply to Ethernet and token ring adapters. ATM and ISDN adapters are not supported by this specification.

A.9.1 Network Device Power State Definitions

For the purpose of the following state definitions “no bus transmission” means that transmit requests from the host processor are not honored, and “no bus reception” means that received data are not transferred to host memory.

Table A-18: Network Device Power State Definitions

State	Status	Definition
D0	Required	Device is on and running and is delivering full functionality and performance to the user Device is fully compliant with the requirements of the attached network
D1	Optional	No bus transmission allowed No bus reception allowed No interrupts can occur Device context may be lost
D2	Optional	No bus transmission allowed No bus reception allowed No interrupts can occur Device context may be lost
D3	Required	Device context is assumed to be lost No bus transmission allowed No bus reception allowed No interrupts can occur

This document does not specify maximum power and maximum latency requirements for the sleeping states because these numbers are very different for different network technologies. The device must meet the requirements of the bus that it attaches to.

Although the descriptions of states D1 and D2 are the same, the choice of whether to implement D1 or D2 or both may depend on bus services required, power requirements, or time required to restore the physical layer. For example, a device designed for a particular bus might include state D1 because it needs a bus service such as a bus clock to support Magic Packet™ wake, and that service is available in the bus device’s D1 power state but not in D2. Also, a device might include both state D1 and state D2 to provide a choice between lower power and lower latency.

A.9.2 Network Device Power Management Policy

Table A-19: Network Device Power Management Policy

Present State	Next State	Cause
D0	Dx	System enters sleep state. If wake is enabled, Dx is the lowest power state (for example, D1, D2, D3) from which the network device supports system wake. An appropriate time-out has elapsed after a “link down” condition was detected. Dx is the lowest power state in which the network device can detect “link up.”
D0	D3	System initiated network shutdown. System enters sleep state and wake is either not enabled or the network device is capable of waking from D3.
D1/D2/D3	D0	System wake (transition to S0), including a wake caused by a network wake event.

A.9.3 Network Device Wake Events

Network wake events are generally the result of either a change in the link status or the reception of a wake frame from the network.

A.9.3.1 Link Status Events

Link status wake events are useful to indicate a change in the network’s availability, particularly when this change may impact the level at which the system should re-enter the sleeping state. For example, a transition from “link off” to “link on” may trigger the system to re-enter sleep at a higher level (for example, S2 versus S3) so that wake frames can be detected. Conversely, a transition from “link on” to “link off” may trigger the system to re-enter sleep at a deeper level (for example, S3 versus S2) since the network is not currently available. The network device should implement an internal delay to avoid unnecessary transitions when the link status toggles on or off momentarily.

A.9.3.2 Wake Frame Events

Wake frame events are used to wake the system whenever meaningful data is presented to the system over the network. Examples of meaningful data include the reception of a Magic Packet™, a management request from a remote administrator, or simply network traffic directly targeted to the local system. In all of these cases the network device was pre-programmed by the policy owner or other software with information on how to identify wake frames from other network traffic. The details of how this information is passed between software and network device depend on the OS and therefore are not described in this specification.

A.9.4 Network Device Minimum Power Capabilities

A network device conforming to this specification must support the D0 and D3 states. Support for the D1 and D2 states is optional.

A.10 PC Card Controller Device Class

The requirements expressed in this section apply to PC Card controller devices and the PC Card slots.

Power management of PC Cards is not defined by this specification. PC Card power management is defined by the relevant power management specification for the card's device class (for example, network, modem, and so on), in conjunction with the PC Card standard (for 16-bit cards) or the PCI Power Management Specification (for CardBus cards).

A.10.1 PC Card Controller Device Power State Definitions

Table A-20: PC Card Controller Device Power State Definitions

State	Status	Definition
D0	Required	Card status change interrupts are fully functional. Card functional interrupts are fully functional. Controller context (for example, memory, I/O windows) is fully functional. Controller interface is fully functional (processor can access cards). Power to cards (slots) is available (may be on or off under software control). The controller is at its highest power consumption level. Bus command response time is at its fastest level. PC Cards can be in any Dx power state (D0-D3). Note: In D0 state, CSTSCHG interrupts can be passed to a system from a powered down PC Card (for more detail, refer to section 5.2.11.2 of PC Card Standard, Electrical Specification).
D1	Optional	Card status change interrupts are disabled. CSTSCHG interrupt events are still detectable by the controller and cause the bus-specific wake signal to be asserted if wake is enabled on the controller. Card functional interrupts are disabled. Controller context is preserved (all register contents must be maintained but memory and I/O windows need not be functional). Controller interface is non-functional (processor cannot access cards). Power to cards (slots) is available (may be on or off; retains power setting it had at time of entry to D1). Power-level consumption for the controller is high but less than D0. The time required to restore the function from the D1 state to the D0 state is quicker than resumption from D3. Bus command response time is equal to or slower than in D0. PC Cards can be in the D1, D2, or D3 power states (not D0). Note: In D1 state, CSTSCHG interrupts can be passed to a system from a powered-down PC Card (for more detail, refer to section 5.2.11.2 of PC Card Standard, Electrical Specification).
D2	Optional	Functionally the same as D1 (may be implemented instead of D1 in order to allow bus and/or system to enter a lower-power state).
D3	Required	Card status change interrupt: Disabled and need not be detected. Card functional interrupt: Disabled and need not be detected. Controller context (for example, memory, I/O windows): Lost. Controller interface: Non-functional (processor can not access cards). Clock to controller: Off. Power to cards (slots): Off (card context lost). Note: If Vcc is removed (for example, PCI Bus B3) while the device is in the D3 state, a bus-specific reset (for example, PCI RST#) must be asserted when power is restored and functions will then return to the D0 state with a full power-on reset sequence. Whenever the transition from D3 to D0 is initiated through assertion of a bus-specific reset, the power-on defaults will be restored to the function by hardware just as at initial power up. The function must then be fully initialized and reconfigured by software.

A.10.2 PC Card Controller Device Power Management Policy

The PC Card controller is a bus controller. As such, its power state is dependent on the devices plugged into the bus (child devices). OSPM will track the state of all devices on the bus and will put the bus into the best possible power state based on the current device requirements on that bus. For example, if the PC Card cards are all in the D1 state, OSPM will put the PC Card controller in the D1 state.

Table A-21: PC Card Controller Device Power Management Policy

Present State	Next State	Cause
D2/D3	D0	Any card in any slot needing to transition to state D0 due to a wake event or because of system usage.
D0	D1	No card in any slot is in state D0.
D0	D2	No card in any slot is in state D0 or D1.
D0	D3	All cards in all slots are in state D3.

A.10.3 PC Card Controller Wake Events

A wake event is any event that would normally assert the controller’s status change interrupt (for example, card insertion, card battery state change, card ReqAttn event, and so on) or ring-indicate signal.

A.10.4 PC Card Controller Minimum Power Capabilities

A PC Card controller device conforming to this specification must support the D0 and D3 states. Support for the D1 or D2 states is optional.

A.11 Storage Device Class

The requirements expressed in this section apply to ATA hard disks, floppy disks, ATAPI and SCSI CD-ROMs, and the IDE channel.

A.11.1 Storage Device Power State Definitions

Table A-22: Hard Disk, CD-ROM and IDE/ATAPI Removable Storage Devices Power State Definitions

State	Status	Definition
D0	Required	Drive controller (for example, interface and control electronics) is functional. Interface mode context (for example, communications timings) is programmed.
D1	Optional	Drive controller (for example, interface and control electronics) is functional. Interface mode context (for example, communications timings) is preserved. Drive motor (for example, spindle) is stopped, with fast-start mode enabled, if available. Laser (if any) is off. Recommended latency to return to D0 is less than 5 seconds. Power consumption in D1 should be no more than 80% of power consumed in D0. Note: For ATA devices, this state is invoked by the Standby Immediate command.
D2	N/A	This state is not defined for storage devices.
D3	Required	Drive controller (for example, interface and control electronics) is not functional; context is lost. Interface mode (for example, communications timings) is not preserved. Drive motor (for example, spindle) is stopped. Laser (if any) is off. Power consumption in D3 is no more than 10% of power consumed in D0. Note: For ATA devices, this state is invoked by the “sleep” command.

Table A-23: Floppy Disk Devices Power State Definitions

State	Status	Definition
D0	Required	Drive controller (for example, interface and control electronics) is functional. Drive motor (for example, spindle) is turning.
D1	N/A	This state is not defined for floppy disk drives.
D2	N/A	This state is not defined for floppy disk drives.
D3	Required	Drive controller (for example, interface and control electronics) is not functional; context is lost. Drive motor (for example, spindle) is stopped.

Table A-24: IDE Channel Devices Power State Definitions

State	Status	Definition
D0	Required	Adapter is functional. Adapter interface mode (for example, communications timings) is programmed. Power is applied to the bus (and all devices connected to it).
D1	N/A	This state is not defined for the IDE Channel.
D2	N/A	This state is not defined for the IDE Channel.
D3	Required	Adapter is non-functional. Adapter interface mode (for example, communications timings) is not preserved. Power to the bus (and all devices connected to it) may be off.

A.11.2 Storage Device Power Management Policy

Table A-25: Hard Disk, Floppy Disk, CD-ROM and IDE/ATAPI Removable Storage Devices Power Management Policy

Present State	Next State	Cause
D3	D0	Device usage (high-priority I/O).
D0	D1*	Device inactivity (no high-priority I/O) for some period of time (T1).
D0	D3	Device inactivity (no high-priority I/O) for a period of time (T2=>T1). System enters sleeping state.
D1 (if supported)	D0	Device usage (High-priority I/O).

Note: For ATA, the D3-to-D0 transition requires a reset of the IDE channel. This means that both devices on a channel must be placed into D3 at the same time.

Table A-26: IDE Channel Devices Power Management Policy

Present State	Next State	Cause
D3	D0	Any device on the channel needing to transition to a state other than state D3.
D0	D3	All devices on the channel in state D3.

A.11.3 Storage Device Wake Events

Storage devices with removable media can, optionally, signal wake upon insertion of media using their bus-specific notification mechanism. There are no other wake events defined for Storage devices.

A.11.4 Storage Device Minimum Power Capabilities

A hard disk, CD-ROM or IDE/ATAPI removable storage device conforming to this specification must support the D0 and D3 states. Support for the D1 state is optional.

A floppy disk and IDE channel device conforming to this specification must support the D0 and D3 states.

APPENDIX B: VIDEO EXTENSIONS

B.1 ACPI Extensions for Display Adapters: Introduction

This section of the document describes a number of specialized ACPI methods to support motherboard graphics devices.

In many cases, system manufacturers need to add special support to handle multiple output devices such as panels and TV-out capabilities, as well as special power management features. This is particularly true for notebook manufacturers. The methods described here have been designed to enable interaction between the platform firmware, video driver, and OS to smoothly support these features.

Systems containing a built-in display adapter are required to implement the ACPI Extensions for Display Adapters.

Table B-1: Video Extension Object Requirements

Method	Description	Requirement
_DOS	Enable/Disable output switching	Required if system supports display switching or LCD brightness levels
_DOD	Enumerate all devices attached to display adapter	Required if integrated controller supports output switching
_ROM	Get ROM Data	Required if ROM image is stored in proprietary format
_GPD	Get POST Device	Required if _VPO is implemented
_SPD	Set POST Device	Required if _VPO is implemented
_VPO	Video POST Options	Required if system supports changing post VGA device
_ADR	Return the unique ID for this device	Required
_BCL	Query list of brightness control levels supported	Required if embedded LCD supports brightness control
_BCM	Set the brightness level	Required if _BCL is implemented
_DDC	Return the EDID for this device	Required if embedded LCD does not support return of EDID via standard interface
_DCS	Return status of output device	Required if the system supports display switching (via hotkey)
_DGS	Query graphics state	Required if the system supports display switching (via hotkey)
_DSS	Device state set	Required if the system supports display switching (via hotkey).

B.2 Video Extension Definitions

Built-in display adapter This is a graphics chip that is built into the motherboard and cannot be replaced. ACPI information is valid for such built-in devices.

Add-in display adapter This is a graphics chip or board that can be added to or removed from the computer. Because the platform firmware cannot have specific knowledge of add-in boards, ACPI information is not available for add-in devices.

Boot-up display adapter This is the display adapter programmed by the platform boot firmware during machine power-on self-test (POST). It is the device upon which the machine will show the initial operating system boot screen, as well as any platform boot firmware messages.

The system can change the boot-up display adapter, and it can switch between the built-in adapter and the add-in adapter.

Display device This is a synonym for the term display adapter discussed above.

Output device This is a device, which is a recipient of the output of a display device. For example, a CRT or a TV is an output device.

B.3 ACPI Namespace

This is an example of the display-related namespace on an ACPI system:

```
GPE          // ACPI General-purpose HW event
_L0x        // Notify(VGA, 0x80) to tell OSPM of the event, when user presses
            // the hot key to switch the output status of the monitor.
            // Notify(VGA, 0x81) to tell the event to OSPM, when there are any
            // changes on the sub-devices for the VGA controller

SB
|- PCI
  |- VGA          // Define the VGA controller in the namespace
    |- \_PS0 / PR0
    |- \_PS1 / PR1
    |- \_PS3
    |- \_DOS          // Method to control display output switching
    |- \_DOD          // Method to retrieve information about child output devices
    |- \_ROM          // Method to retrieve the ROM image for this device
    |- \_GPD          // Method for determining which VGA device will post
    |- \_SPD          // Method for controlling which VGA device will post
    |- \_VPO          // Method for determining the post options
    |- CRT          // Child device CRT
      |- \_ADR          // Hardware ID for this device
      |- \_DDC          // Get EDID information from the monitor device
      |- \_DCS          // Get current hardware status
      |- \_DGS          // Query desired hardware active \ inactive state
      |- \_DSS          // Set hardware active \ inactive state
      |- \_PS0 \
      |- \_PS1 - Power methods
      |- \_PS2 - for the output device
      |- \_PS3 /
    |- LCD          // Child device LCD
      |- \_ADR          // Hardware ID for this device
      |- \_DDC          // Get EDID information from the monitor device
```

(continues on next page)

(continued from previous page)

```

|- \_DCS // Get current hardware status
|- \_DGS // Query desired hardware active \ inactive state
|- \_DSS // Set hardware active \ inactive state
|- \_BCL // Brightness control levels
|- \_BCM // Brightness control method
|- \_BQC // Brightness Query Current Level
|- \_PS0 \
|- \_PS1 - Power methods
|- \_PS2 - for the output device
|- \_PS3 /
|- TV // Child Device TV
|- \_ADR // Hardware ID for this device
|- \_DDC // Get EDID information from the monitor device
|- \_DCS // Get current hardware status
|- \_DGS // Query desired hardware active \ inactive state
|- \_DSS // Set hardware active \ inactive state

```

The LCD device represents the built-in output device. Mobile PCs will always have a built-in LCD display, but desktop systems that have a built-in graphics adapter generally don't have a built-in output device.

B.4 Display-specific Methods

The methods described in this section are all associated with specific display devices. This device-specific association is represented in the namespace example in the previous section by the positioning of these methods in a device tree.

B.4.1 _DOS (Enable/Disable Output Switching)

Many ACPI machines currently reprogram the active display output automatically when the user presses the display toggle switch on the keyboard. This is done because most video device drivers are currently not capable of being notified synchronously of such state changes. However, this behavior violates the ACPI specification, because the system modifies some graphics device registers.

The existence of the _DOS method indicates that the platform runtime firmware is capable of automatically switching the active display output or controlling the brightness of the LCD. If it exists at all, the _DOS method must be present for all display output devices. This method is required if the system supports display switching or LCD brightness control.

Arguments:(1)

Arg0 - An **Integer** containing the encoded switching controls (see below)

Return Value:

None

Additional Argument Information:

Bits [1:0]:

```

0 - The platform runtime firmware should not automatically switch
(toggle) the active display output, but instead just save the desired
state change for the display output devices in variables associated with
each display output, and generate the display switch event. OSPM can
query these state changes by calling the \_DGS method.

```

(continues on next page)

(continued from previous page)

- 1 - The platform runtime firmware should automatically switch (toggle) the active display output, with no interaction required on the OS part. The display switch event should not be generated in this case.
- 2 - The `_DGS` values should be locked. It's highly recommended that the platform runtime firmware do nothing when hotkey pressed. No switch, no notification.
- 3 - The platform runtime firmware should not automatically switch (toggle) the active display output, but instead generate the display switch event notify codes 0x82, 0x83, or 0x84. OSPM will determine what display output state should be set, and change the display output state without further involvement from the platform runtime firmware.

Bit [2]:

- 0 - The platform runtime firmware should automatically control the brightness level of the LCD when the power changes from AC to DC.
- 1 - The platform runtime firmware should not automatically control the brightness level of the LCD when the power changes from AC to DC.

The `_DOS` method controls this automatic switching behavior. This method should do so by saving the parameter passed to this method in a global variable somewhere in the platform runtime firmware data segment. The platform runtime firmware then checks the value of this variable when doing display switching. This method is also used to control the generation of the display switching **Notify (VGA, 0x80/0x81)**.

The platform runtime firmware, when doing switching of the active display, must verify the state of the variable set by the `_DOS` method. The default value of this variable must be 1.

B.4.2 `_DOD` (Enumerate All Devices Attached to the Display Adapter)

This method is used to enumerate devices attached to the display adapter. This method is required if integrated controller supports output switching.

On many laptops today, a number of devices can be connected to the graphics adapter in the machine. These devices are on the motherboard and generally are not directly enumerable by the video driver; for this reason, all motherboard VGA attached devices are listed in the ACPI namespace.

These devices fall into two categories:

- **Video output devices.** For example, a machine with a single display device on the motherboard can have three possible output devices attached to it, such as a TV, a CRT, or a panel.
- **Non-video output devices.** For example, TV Tuner, DVD decoder, Video Capture. They just attach to VGA and their power management closely relates to VGA.

Both ACPI and the video driver have the ability to program and configure output devices. This means that both ACPI and the video driver must enumerate the devices using the same IDs. To solve this problem, the `_DOD` method returns a list of devices attached to the graphics adapter, along with device-specific configuration information. This information will allow the cooperation between ACPI components and the video driver.

Every child device enumerated in the ACPI namespace under the graphics adapter must be specified in this list of devices. Each display device must have its own ID, which is unique with respect to any other attachable devices enumerated.

Arguments:

None

Return Value:

A **Package** containing a variable-length list of **Integers**, each of which contains the 32-bit device attribute of a child device (See *Table B-2* below).

Example

```
Method (_DOD, 0) {
    Return (
        Package ()
        {
            0x00000110, // Primary LCD panel, not detectable by firmware
            0x80000100, // CRT type display, not detectable by firmware
            0x80000220, // TV type display, not detectable by the firmware
            0x80000411, // Secondary LCD panel, not detectable by firmware
        }
    )
}
```

Table B-2: Video Output Device Attributes

Bits	Definition
15:0	<p>Device ID. The device ID must match the ID’s specified by Video Chip Vendors. They must also be unique under VGA namespace:</p> <p>Bits [3:0] Display Index: A zero-based instance of the Display, when multiple displays of the same type are attached, regardless of where it is associated. Starting from the first adapter and its first display of the type on the first integrated internal device and then incrementing per device-function according to its relative port number.</p> <p>Bits [7:4] Display Port Attachment: This field differentiates displays of the same type attached at different points of one adapter. The zero-based number scheme is specific to each Video Chip Vendors’ implementation.</p> <p>Bits [11:8] Display Type: Describes the specific type of Display Technology in use.</p> <ul style="list-style-type: none"> 0 – Other 1 – VGA* CRT or VESA* Compatible Analog Monitor 2 – TV/HDTV or other Analog-Video Monitor 3 – External Digital Monitor (see note 1) 4 – Internal/Integrated Digital Flat Panel (see note 2) 5-15 – Reserved for future use <p>Bits [15:12] Chipset-vendor specific</p>
16	Platform boot firmware can detect the device.
17	Non-VGA output device whose power is related to the VGA device. This can be used when specifying devices like TV Tuner, DVD decoder, Video Capture ... etc.
20:18	For VGA multiple-head devices, this specifies head or pipe ID e.g. for Dual-Pipe*, Dual-Display*, Duo-View*, TwinView*, Triple-View* ... etc, beginning with 0 for head 0 or single-head device and increasing for each additional head.
30:21	<i>Reserved (must be 0)</i>

continues on next page

Table B.2 – continued from previous page

31	Device ID Scheme: 1 - Uses the bit-field definitions above (bits 15:0) 0 - Other scheme, contact the Video Chip Vendor
----	--

Note: 1: An “External Digital Monitor” is an external display device attachable via a user-accessible connector standard (e.g. DFP* or DVI* Compatible Monitors).

2: An “Internal Flat Panel” is a non-detachable fixed pixel display device, including a backlight, and is internally associated, without user-accessible connectors, to the Video Chip (e.g. TFT LCD via TMDS*, LVDS* interface).

As mentioned in the above table, a “Pipe” or “Head” refers to a unique display content stream e.g. at a particular color-depth, resolution, and refresh-rate. The “Port” refers to the display output device attachment and may include a DAC, encoder or other mechanism required to support a given display end-point. The “Display Type” describes the generalized class of display output technology, and the means of integration. The “Display Index” is then an index that assists in creating a unique identifier display end-points in scenarios where other attributes are the same.

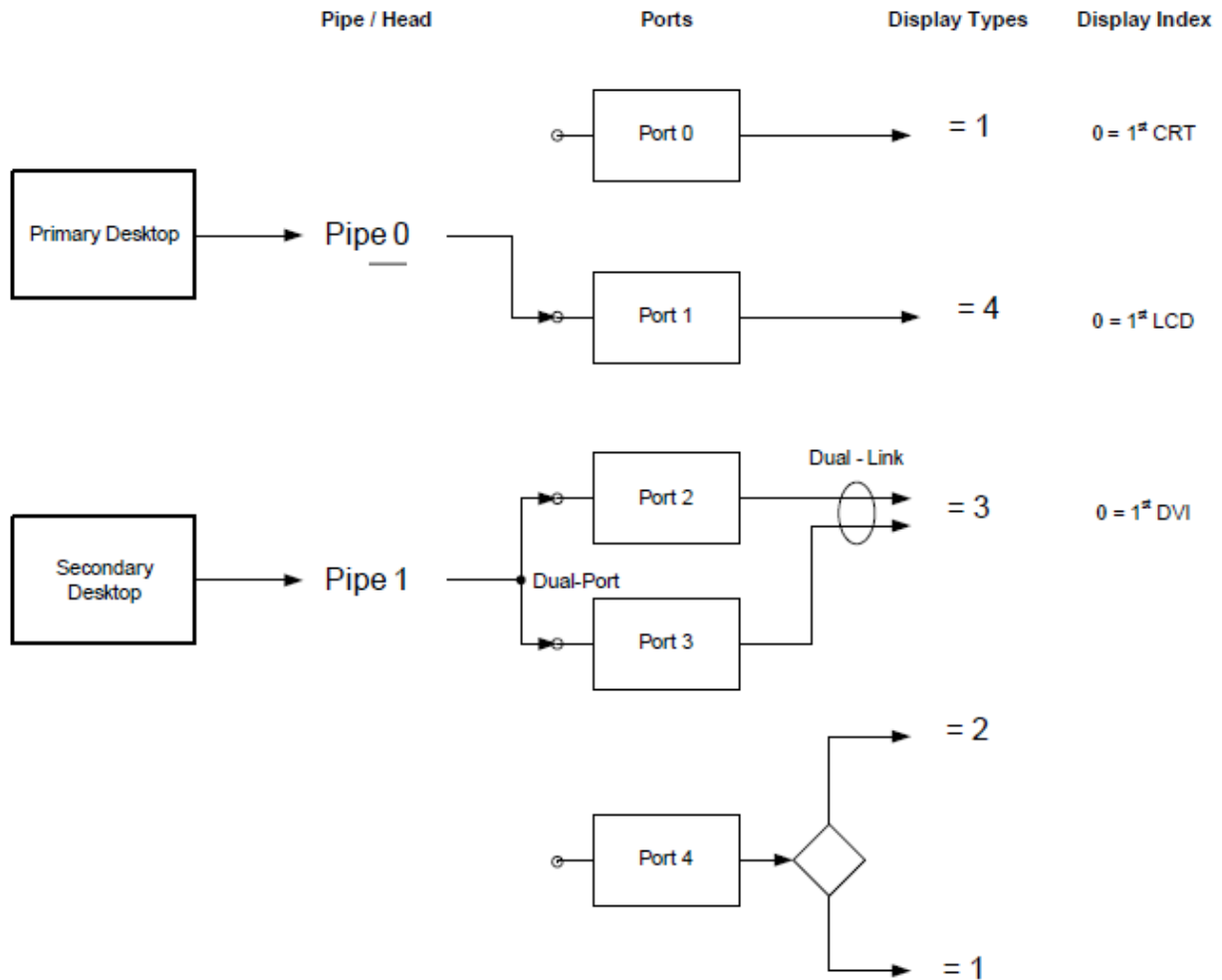

Fig. B-1: Example Display Architecture

Table B-3: Example Device IDs

Bits	Definition
0x000xyyyy	Bit [31] = 0. Other proprietary scheme - 0x110 Device ID is an exception (see note 3)
0x00000110	Integrated LCD Panel #1 using a common, backwards compatible ID
0x80000100	Integrated VGA CRT or VESA compatible Monitor #1 on Port0
0x80000240	Integrated TV #1 on Port4
0x80000410	Integrated Internal LCD Panel #1 on Port1
0x80000421	LVDS Panel #2 Dual-Link using Port2 & 3 (see note 4)
0x80000131	VGA CRT or VESA compatible Monitor #2 on Port3
0x80000121	Dual-Link VGA CRT or VESA compatible Monitor #2 using Port2 & 3 (see note 4)
0x80000320	DVI Monitor #1 on Port2 (shares Port2 with a Dual-Function DVI/TV Encoder) (see note 5)
0x80000331	DVI Monitor #2 on Port3
0x80000330	Dual-Link DVI Monitor #1 using Port2 & 3
0x80000231	TV #2 on Port2 (shares Port2 with a Dual-Function DVI/TV Encoder) (see note 5)

Note: 3: When Bit [31] is 0, no assumptions can be made on which ID will be used for any particular display type. Contact the Video Chip vendor for details of the ID scheme employed.

4: In certain cases multiple Displays Ports may be combined to increase bandwidth for a particular Display in higher-resolution modes. In this situation, the Display Type and Port Number should remain the same in order to retain a consistent ID for the same device, regardless of the selected display mode.

5: In certain cases, more than one type of display (and connector) may be supportable on a single Port (e.g. DVI + TV + CRT on a single Display Encoder device), while only one display is selectable at any time. In this case, the Port Number field of the ID may be the same as other Display IDs, however the other fields (e.g. Display Type) provide uniqueness.

B.4.3 _ROM (Get ROM Data)

This method is used to get a copy of the display devices' ROM data. This method is required when the ROM image is stored in a proprietary format such as stored in the platform firmware ROM. This method is not necessary if the ROM image can be read through a standard PCI interface (using ROM BAR). If _ROM is present, it is preferred over the image read through the standard PCI interface, in order to allow platform runtime firmware to provide re-configured ROM data via the method.

The video driver can use the data returned by this method to program the device. The format of the data returned by this function is a large linear buffer limited to 4 KB. The content of the buffer is defined by the graphics independent hardware vendor (IHV) that builds this device. The format of this ROM data will traditionally be compatible with the ROM format of the normal PCI video card, which will allow the video driver to program its device, independently of motherboard versus add-in card issues.

The data returned by the _ROM method is implementation-specific data that the video driver needs to program the device. This method is defined to provide this data as motherboard devices typically don't have a dedicated option ROM. This method will allow a video driver to get the key implementation specific data it needs so that it can fully control and program the device without platform runtime firmware support.

Arguments:(2)

Arg0 - An Integer containing the offset of the display device ROM data

Arg1 - An Integer containing the size of the buffer to fill in (up to 4K).

Return Value:

A Buffer containing the requested ROM data

B.4.4 _GPD (Get POST Device)

This method is required if the _VPO method is implemented.

This method is used as a mechanism for the OS to query a CMOS value that determines which VGA device will be posted at boot. A zero return value indicates the motherboard VGA will be posted on the next boot, a 1 indicates a PCI VGA device will be posted, and a 2 indicates an AGP VGA device will be posted.

Arguments:

None

Return Value:

An **Integer** containing encoded post information (32 bits valid):

```
Bits [1:0]
 00 - Post the motherboard VGA device
 01 - Post an add-in PCI VGA device
 10 - Post an add-in AGP VGA device
 11 - Post an add-in PCI-Express VGA device
Bits [31:2] - Reserved (must be 0)
```

B.4.5 _SPD (Set POST Device)

This method is required if the _VPO method is implemented.

This method is used as a mechanism for the OS to update a CMOS value that determines which video device will be posted at boot. A zero argument will cause the “motherboard” to be posted on the next boot, a 1 will cause an add-in PCI device to be posted, and a 2 will cause an add-in AGP device to be posted.

Arguments:(1)

Arg0 - An **Integer** containing encode post information (32 bits valid):

```
Bits [1:0]
 00 - Post the motherboard VGA device
 01 - Post an add-in PCI VGA device
 10 - Post an add-in AGP VGA device
 11 - Post an add-in PCI-Express VGA device
Bits [31:2] - Reserved (must be 0)
```

Return Value:

An **Integer** containing the status of the operation:

```
0 - Operation was successful
Non-zero - Operation failed
```

Example:

```
Method (_SPD, 1) { // Make the motherboard device the device to post }
```

B.4.6 _VPO (Video POST Options)

This method is required for systems with video devices built onto the motherboard and support changing post-VGA device.

This method is used as a mechanism for the OS to determine what options are implemented. This method will be used in conjunction with _GPD and _SPD.

Arguments:

None

Return Value:

An **Integer** containing the options that are implemented and available:

```
Bit [0] - Posting the motherboard VGA device is an option.
         (Bit [0] should always be set)
Bit [1] - Posting a PCI VGA device is an option.
Bit [2] - Posting an AGP VGA device is an option.
Bit [3] - Posting a PCI-Express VGA device is an option.
Bits [31:4] - Reserved (must be zero)
```

B.5 Notifications for Display Devices

Display devices may need to know about external, asynchronous events. In order to accommodate that, the following notifications are defined.

The event number is standardized because the event will be handled by the OS directly under certain circumstances (see _DOS method in this specification).

These notifications are valid for Display Devices

Table B-4: Notifications for Display Devices

Value	Description
0x80	Cycle Output Device. Used to notify OSPM whenever the state of one of the output devices attached to the VGA controller has been switched or toggled. This event will, for example, be generated when the user presses a hotkey to switch the active display output from the LCD panel to the CRT.
0x81	Output Device Status Change. Used to notify OSPM whenever the state of any output devices attached to the VGA controller has been changed. This event will, for example, be generated when the user plugs-in or remove a CRT from the VGA port. In this case, OSPM will re-enumerate all devices attached to VGA
0x82	Cycle Display Output Hotkey Pressed. Used to notify OSPM whenever the user has pressed the Cycle display hotkey.
0x83	Next Display Output Hotkey Pressed. Used to notify OSPM whenever the user has pressed the Next display hotkey.
0x84	Previous Display Output Hotkey Pressed. Used to notify OSPM whenever the user has pressed the Previous display hotkey.

B.6 Output Device-specific Methods

The methods in this section are methods associated with the display output device.

B.6.1 **_ADR** (Return the Unique ID for this Device)

This method returns a unique ID representing the display output device. All output devices must have a unique hardware ID. This method is required for all The IDs returned by this method will appear in the list of hardware IDs returned by the **_DOD** method.

Arguments:

None

Return Value:

An Integer containing the device ID (32 bits)

Example:

```
Method (_ADR, 0) {
return(0x0100)           // device ID for this CRT
}
```

This method is required for all output display devices.

B.6.2 **_BCL** (Query List of Brightness Control Levels Supported)

This method allows the OS to query a list of brightness level supported by built-in display output devices. (This method is not allowed for externally connected displays.) This method is required if an integrated LCD is present and supports brightness levels.

Each brightness level is represented by a number between 0 and 100, and can be thought of as a percentage. For example, 50 can be 50% power consumption or 50% brightness, as defined by the OEM.

The OEM may define the number 0 as “Zero brightness” that can mean to turn off the lighting (e.g. LCD panel backlight) in the device. This may be useful in the case of an output device that can still be viewed using only ambient light, for example, a transfective LCD. If **Notify(Output Device, 0x85)** for “Zero brightness” is issued, **OSPM** may be able to turn off the lighting by calling **_BCM(0)**.

Arguments:

None

Return Value:

A variable-length Package containing a list of Integers representing the supported brightness levels. Each integer has 8 bits of significant data.

Example:

```
Method (_BCL, 0) {
// List of supported brightness levels
Return (Package(7) {
80,           // level when machine has full power
50,           // level when machine is on batteries
// other supported levels:
20, 40, 60, 80, 100})
}
```

The first number in the package is the level of the panel when full power is connected to the machine. The second number in the package is the level of the panel when the machine is on batteries. All other numbers are treated as a list of levels OSPM will cycle through when the user toggles (via a keystroke) the brightness level of the display.

These levels will be set using the `_BCM` method described in the following section.

B.6.3 `_BCM` (Set the Brightness Level)

This method allows OSPM to set the brightness level of a built-in display output device.

The OS will only set levels that were reported via the `_BCL` method. This method is required if `_BCL` is implemented.

Arguments:(1)

Arg0 - An **Integer** containing the new brightness level

Return Value:

None

Example:

```
Method (_BCM, 1) { // Set the requested level }
```

The method will be called in response to a power source change or at the specific request of the end user, for example, when the user presses a function key that represents brightness control.

B.6.4 `_BQC` (Brightness Query Current level)

This optional method returns the current brightness level of a built-in display output device. If present, it must be set by the platform for initial brightness.

Arguments:

None

Return Value:

An **Integer** containing the current brightness level (must be one of the values returned from the `_BCL` method)

B.6.5 `_DDC` (Return the EDID for this Device)

This method returns an EDID (Extended Display Identification Data) structure that represents the display output device. This method is required for integrated LCDs that do not have another standard mechanism for returning EDID data.

Arguments:

Arg0 - An Integer containing a code for the return data length:

```
1 - Return 128 bytes of data
2 - Return 256 bytes of data
3 - Return 384 bytes of data
4 - Return 512 bytes of data
```

Return Value:

Either a **Buffer** containing the requested data (of the length specified in Arg0), or an **Integer** (value 0) if Arg0 was invalid

Example:

```
Method (_DDC, 2) {
    (LEqual (Arg0, 1)) { Return (Buffer(128){ , , , , }) }
    If (LEqual (Arg0, 2)) { Return (Buffer(256){ , , , , }) }
    Return (0)
}
```

The buffer will later be interpreted as an EDID data block. The format of this data is defined by the VESA EDID specification.

B.6.6 _DCS (Return the Status of Output Device)

This method is required if hotkey display switching is supported.

Arguments:

None

Return Value:

An **Integer** containing the device status (32 bits) (see Table B-5 below).

Table B-5: Output Device Status

Bits	Definition
0	Output connector exists in the system now
1	Output is activated
2	Output is ready to switch
3	Output is not defective (it is functioning properly)
4	Device is attached (this is optional)
31:5	Reserved (must be zero)

Example:

- If the output signal is activated by _DSS, _DCS returns 0x1F or 0x0F.
- If the output signal is inactivated by _DSS, _DCS returns 0x1D or 0x0D.
- If the device is not attached or cannot be detected, _DCS returns 0x0xxxx and should return 0x1xxxx if it is attached.
- If the output signal cannot be activated, _DCS returns 0x1B or 0x0B.
- If the output connector does not exist (when undocked), _DCS returns 0x00.

B.6.7 _DGS (Query Graphics State)

This method is used to query the state (active or inactive) of the output device. This method is required if hotkey display switching is supported.

Arguments:

None

Return Value:

An **Integer** containing the device state (32 bits) (see Table B-6 below)

Table B-6: Device State for _DGS

Bits	Definition
0	0 - Next desired state is inactive / 1 - Next desired state is active
31:1	Reserved (must be zero)

The desired state represents what the user wants to activate or deactivate, based on the special function keys the user pressed. OSPM will query the desired state when it receives the display toggle event (described earlier).

B.6.8 _DSS (Device Set State)

OSPM will call this method when it determines the outputs can be activated or deactivated. OSPM will manage this to avoid flickering as much as possible. This method is required if hotkey display switching is supported.

Arguments:(1)

Arg0 - An Integer containing the new device state (32 bits) (see Table B-7 below)

Return Value:

None

Table B-7: Device State for _DSS

Bits	Definition
0	0 - Set output device to inactive state 1 - Set output device to active state
30	0 - Do whatever Bit [31] requires 1 - Don't do actual switching, but need to change _DGS to next state
31	0 - Don't do actual switching, just cache the change 1 - If Bit [30] = 0, commit actual switching, including any _DSS with MSB=0 called before If Bit [30] = 1, don't do actual switching, change _DGS to next state
29:1	Reserved (must be zero)

Example Usage:

OS may call in such an order to turn off CRT, and turn on LCD:

```
CRT._DSS(0);
LCD._DSS(80000001L);

or:

LCD._DSS(1);
CRT._DSS(80000000L);
```

OS may call in such an order to force platform runtime firmware to make `_DGS` jump to next state without actual CRT, LCD switching:

```
CRT._DSS(40000000L);
LCD._DSS(C0000001L);
```

B.7 Notifications Specific to Output Devices

Output devices may need to know about external, asynchronous events. In order, each of these events corresponds to accommodate that, pressing a key or button on the following machine. Using these notifications is not appropriate if no physical device exists that is associated with them. OSPM may ignore any of these notifications if, for example the current user does not have permission to change the state of the output device. These notifications are only valid for Output Devices.

Table B-8: Notification Values for Output Devices

Value	Description
0x85	Cycle Brightness. Used to notify OSPM that the output device brightness should be increased by one level. Used to notify OSPM that the user pressed a button or key that is associated with cycling brightness. A useful response by OSPM would be to increase output device brightness by one or more levels. (Levels are defined in <code>_BCL</code> .) If the brightness level is currently at the maximum value, it should be set to the minimum level.
0x86	Increase Brightness. Used to notify OSPM that the output device brightness should be increased by one or more levels as defined by the <code>_BCL</code> object. Used to notify OSPM that the user pressed a button or key that is associated with increasing brightness. If the brightness level is currently at the maximum value, OSPM may should ignore the notification.
0x87	Decrease Brightness. Used to notify OSPM that the output device brightness should be decreased by one or more levels as defined by the <code>_BCL</code> object. Used to notify OSPM that the user pressed a button or key that is associated with decreasing device brightness. If the brightness level is currently at the minimum value, OSPM may should ignore the notification.
0x88	Zero Brightness. Used to notify OSPM that the output device brightness should be zeroed, effectively turning off any lighting that is associated with the device. Used to notify OSPM that the user pressed a button or key associated with zeroing device brightness. This is not to be confused with putting the device in a D3 state. While the brightness may be decreased to zero, the device may still be displaying, using only ambient light.
0x89	Display Device Off. Used to notify OSPM that the device should be put in an off state, one that is not active or visible to the user, usually D3, but possibly D1 or D2. Used to notify OSPM that the user pressed a low power button or key associated with putting the device in an off state. There is no need for a corresponding “device on” notification, for two reasons. First, OSPM may choose to toggle device state when this event is pressed multiple times. Second, OSPM may (and probably will) choose to turn the monitor on whenever the user types on the keyboard, moves the mouse, or otherwise indicates that he or she is attempting to interact with the machine.

B.8 Notes on State Changes

It is possible to have any number of simultaneous active output devices. It is possible to have 0, 1, 2 . . . and so on active output devices. For example, it is possible for both the LCD device and the CRT device to be active simultaneously. It is also possible for all display outputs devices to be inactive (this could happen in a system where multiple graphics cards are present).

The state of the output device is separate from the power state of the device. The “active” state represents whether the image being generated by the graphics adapter would be sent to this particular output device. A device can be powered off or in a low-power mode but still be the active output device. A device can also be in an off state but still be powered on.

Example of the display-switching mechanism:

The laptop has three output devices on the VGA adapter. At this moment in time, the panel and the TV are both active, while the CRT is inactive. The automatic display-switching capability has been disabled by OSPM by calling `_DOS(0)`, represented by global variable `display_switching = 0`.

The platform runtime firmware, in order to track the state of these devices, will have three global variable to track the state of these devices. There are currently initialized to:

```
crt_active - 0 panel_active - 1 tv_active - 1
```

The user now presses the display toggle switch, which would switch the TV output to the CRT.

The platform runtime firmware first updates three temporary variables representing the desired state of output devices:

```
want_crt_active - 1 want_panel_active - 1 want_tv_active - 0
```

Then the platform runtime firmware checks the `display_switching` variable. Because this variable is set to zero, the platform runtime firmware does not do any device reprogramming, but instead generates a **Notify** (VGA, 0x80/0x81) event for the display. This event will be sent to OSPM.

OSPM will call the `_DGS` method for each enumerated output device to determine which devices should now be active. OSPM will determine whether this is possible, and will reconfigure the internal data structure of the OS to represent this state change. The graphics modes will be recomputed and reset.

Finally, OSPM will call the `_DSS` method for each output device it has reconfigured.

Note: OSPM may not have called the `_DSS` routines with the same values and the `_DGS` routines returned, because the user may be overriding the default behavior of the hardware-switching driver or operating system-provided UI. The data returned by the `_DGS` method (the `want_XXX` values) are only a hint to the OS as to what should happen with the output devices.

If the display-switching variable is set to 1, then the platform runtime firmware would not send the event, but instead would automatically reprogram the devices to switch outputs. Any legacy display notification mechanism could also be performed at this time.

APPENDIX C: DEPRECATED CONTENT

This section lists content (if any) that is being deprecated from the ACPI specification in this release.

Section 8.4: Declaring Processors

In the first paragraph of this section, removed the following text:

Declaration of processors in the `_PR` scope was only required for platforms desiring compatibility with ACPI 1.0-based OSPM implementations. It is deprecated for all other uses. Processors are declared via the ASL **Device** statement. Declarations via the ASL **Processor statement** are deprecated.

Section 9.4: Battery Device

A battery device is required to either have an ACPI Smart Battery Table or a Control Method Battery interface. In the case of an ACPI Smart Battery Table, the Definition Block needs to include a Bus/Device Package for the SMBus host controller. This will install an OS specific driver for the SMBus, which in turn will locate the Smart Battery System Manager or Smart Battery Selector and Smart Battery Charger SMBus devices.

The Control Method Battery interface is defined in [Section 10.2](#).

Section 9.7: Embedded Controller Device

Operation of the embedded controller host controller register interface requires that the embedded controller driver has ACPI-specific knowledge. Specifically, the driver needs to provide an “operational region” of its embedded controller address space, and needs to use an ACPI event to service the host controller interface. For more information, see [Section 12](#).

The embedded controller device object provides the `_HID` of an ACPI-integrated embedded controller device of PNP0C09 and the host controller register locations using the device standard methods. In addition, the embedded controller must be declared as a named device object that includes a set of control methods. For more information, see [Section 12.11](#).

Section 8.4.1 `_PDC` (Processor Driver Capabilities)

The use of `_PDC` is deprecated in ACPI 3.0 in favor of `_OSC`. For backwards compatibility, `_PDC` may be implemented using `_OSC` as follows:

```

Method(_PDC,1)
{
    CreatedWordField (Arg0, 0, REVS)
    CreatedWordField (Arg0, 4, SIZE)

    //
    // Local0 = Number of bytes for Arg0
    //
    Store (SizeOf (Arg0), Local0)

    //
    // Local1 = Number of Capabilities bytes in Arg0
    //
    Store (Subtract (Local0, 8), Local1)

    //
    // TEMP = Temporary field holding Capability DWORDs
    //
    CreateField (Arg0, 64, Multiply (Local1, 8), TEMP)

    //
    // Create the Status (STS0) buffer with the first DWORD = 0
    // This is required to return errors defined by \_OSC.
    //
    Name (STS0, Buffer () {0x00, 0x00, 0x00, 0x00})

    //
    // Concatenate the \_PDC capabilities bytes to the STS0 Buffer
    // and store them in a local variable for calling OSC
    //
    Concatenate (STS0, TEMP, Local2)

    //
    // Note: The UUID passed into \_OSC is CPU vendor specific. Consult CPU
    // vendor documentation for UUID and Capabilities Buffer bit
    // definitions
    //
    \_OSC (ToUUID("4077A616-290C-47BE-9EBD-D87058713953"), REVS, SIZE,
    Local2)
}

```

_OSC (Operating System Capabilities) describes the *_OSC* object that can be used to convey processor related OSPM capabilities to the platform. Consult vendor-specific CPU documentation for the UUID and Capabilities Buffer bit definitions used by *_OSC* for a specific processor.

DESCRIPTION_HEADER Signatures for tables reserved by ACPI

- – “CDIT”
 - **Component Distance Information Table.** See [Links to ACPI-Related Documents](#) under the heading “Component Distance Information Table”.
- – “CRAT”
 - **Component Resource Attribute Table.** See [Links to ACPI-Related Documents](#) under the heading “Component Resource Attribute Table”.

A

ACPI Hardware, **15**
 ACPI Machine Language (AML), **15**
 ACPI Namespace, **15**
 ACPI Non-Volatile-Sleeping Memory (NVS) ., **773**
 ACPI Reclaim Memory., **773**
 ACPI registers., **771**
 ACPI Source Language (ASL), **15**
 Add-in Card, **15**
 Add-in display adapter, **1040**
 Address Range Scrub (ARS), **16**
 Advanced Configuration and Power Interface (ACPI), **15**
 Advanced Programmable Interrupt Controller (APIC), **15**
 Appliance PC, **119**

B

Battery management, **26**
 BIOS, **16**
 Boot Firmware, **16**
 Boot-up display adapter, **1040**
 Built-in display adapter, **1040**

C

C0 Processor Power State, **25**
 C1 Processor Power State, **25**
 C2 Processor Power State, **25**
 C3 Processor Power State, **25**
 Cache memory configuration., **771**
 Central Processing Unit (CPU) or Processor, **16**
 Component, **16**
 Configuration / Plug and Play, **26**
 Control Method, **16**
 CPU configuration., **771**

D

D0 (Fully-On), **23**
 D1, **23**
 D2, **23**

D3 (Off), **23**
 D3hot, **23**
 Desktop, **118**
 Device, **16**
 Device and processor performance management, **26**
 Device Context, **16**
 Device Firmware, **16**
 Device Physical Address (DPA), **16**
 Device power management, **26**
 Differentiated System Description Table (DSDT), **16**
 Display device, **1040**

E

Embedded Controller, **17**
 Embedded Controller Interface, **17**
 Emulation mode, **559**
 Enterprise Server, **119**
 Expansion ROM Firmware, **17**
 eXtended Root System Description Table (XSDT), **21**

F

Firmware, **17**
 Firmware ACPI Control Structure (FACS), **17**
 Firmware Storage Device, **17**
 Fixed ACPI Description Table (FADT), **17**
 Fixed Feature Events, **17**
 Fixed Feature Registers, **17**
 Fixed Features, **17**
 Functional device configuration., **771**

G

G0 Working, **22**
 G1 Sleeping, **22**
 G2/S5 Soft Off, **21**
 G3 Mechanical Off, **21**
 General-Purpose Event Registers, **17**
 Generic Feature, **17**
 Generic Interrupt Controller (GIC), **17**

Global System Status, **18**

H

HBA, **558**

Host Processor, **18**

Host Processor Boot Firmware, **18**

Host Processor Runtime Firmware, **18**

Hybrid Device, **559**

I

I/O APIC, **18**

I/O SAPIC, **18**

Ignored Bits, **18**

Intel Architecture–Personal Computer
(*IA-PC*), **18**

L

Label Storage Area, **18**

Legacy, **18**

Legacy BIOS, **18**

Legacy Hardware, **18**

Legacy OS, **18**

Local APIC, **18**

Local SAPIC, **18**

M

Management Firmware, **18**

Memory controller configuration., **771**

Mobile, **118**

Multiple APIC Description Table (*MADT*),
19

N

Namespace, **19**

Native mode, **559**

Native SATA aware, **558**

Non-Host Processor, **19**

Non-native SATA aware, **558**

NVDIMM, **19**

O

Object, **19**

Object name, **19**

Operating System–directed Power
Management (*OSPM*), **19**

Option ROM Firmware, **19**

Output device, **1040**

P

P0 Performance State, **25**

P1 Performance State, **25**

Package, **19**

Performance Server, **119**

Peripheral, **19**

Persistent Memory (*pmem*), **19**

Platform, **19**

Platform Boot Firmware, **19**

Platform Firmware, **19**

Platform Runtime Firmware, **19**

Pn Performance State, **25**

Power Button, **19**

Power Management, **19**

Power Resources, **20**

Power Sources, **20**

Processor power management, **26**

R

Register Grouping, **20**

Reserved Bits, **20**

Root System Description Pointer (*RSDP*),
20

Root System Description Table (*RSDT*), **20**

Runtime Firmware, **20**

S

S1 Sleeping State, **24**

S2 Sleeping State, **24**

S3 Sleeping State, **24**

S4 Non-Volatile Sleep, **22**

S4 Sleeping State, **24**

S5 Soft Off State, **25**

Secondary System Description Table
(*SSDT*), **20**

Sleep Button, **20**

Smart Battery Subsystem, **20**

Smart Battery Table, **20**

SMBus Controller, **27**

SMBus Interface, **20**

Software, **20**

SOHO Server, **119**

Streamlined Advanced Programmable
Interrupt Controller (*SAPIC*), **20**

System, **20**

System BIOS, **20**

System Context, **20**

System Control Interrupt (*SCI*), **21**

System Events, **26**

System Management Bus (*SMBus*), **21**

System Management Interrupt (*SMI*), **21**

System Physical Address (*SPA*), **20**

System power management, **26**

T

Tablet, **119**

Thermal management, **26**

Thermal States, **21**

U

UEFI, [21](#)

UEFI Drivers, [21](#)

W

Workstation, [118](#)